

Three Phase Power Controller

ASR-002

USER MANUAL



ISO-9001 CERTIFIED MANUFACTURER

GW INSTEK

This manual contains proprietary information, which is protected by copyright. All rights are reserved. No part of this manual may be photocopied, reproduced or translated to another language without prior written consent of Good Will company.

The information in this manual was correct at the time of printing. However, Good Will continues to improve products and reserves the rights to change specification, equipment, and maintenance procedures at any time without notice.

Good Will Instrument Co., Ltd.
No. 7-1, Jhongsing Rd., Tucheng Dist., New Taipei City 236, Taiwan.

Table of Contents

SAFETY INSTRUCTIONS	4
GETTING STARTED	7
ASR-002 Overview	7
Front Panel.....	8
Rear Panel	10
OPERATION	12
Basic Operation.....	13
Advance Setting.....	15
Phase Angle Setting.....	17
Voltage Ramp Setting	18
Frequency Sweep Setting	19
Unit Setting Value Display	20
Wire Connection & Accessories	23
APPENDIX	25
ASR-002 Dimension.....	25
Using the Rack Mount Kit.....	26
Command List	28
ASR-002 Error Messages.....	29

S SAFETY INSTRUCTIONS

This chapter contains important safety instructions that you must follow during operation and storage. Read the following before any operation to ensure your safety and to keep the instrument in the best possible condition.

Safety Symbols

These safety symbols may appear in this manual or on the instrument.



WARNING

Warning: Identifies conditions or practices that could result in injury or loss of life.



CAUTION

Caution: Identifies conditions or practices that could result in damage to the ASR-002 or to other properties.



DANGER High Voltage



Attention Refer to the Manual



Protective Conductor Terminal



Earth (ground) Terminal



Do not dispose electronic equipment as unsorted municipal waste. Please use a separate collection facility or contact the supplier from which this instrument was purchased.

Safety Guidelines

General Guideline



CAUTION

- Do not place any heavy object on the ASR-002.
- Avoid severe impact or rough handling that leads to damaging the ASR-002.
- Do not discharge static electricity to the ASR-002.
- Use only mating connectors, not bare wires, for the terminals.
- Do not block the cooling fan opening.
- Do not disassemble the ASR-002 unless you are qualified.
- If the equipment is used in a manner not specified by the manufacturer, the protection provided by the equipment may be impaired.

Power Supply



WARNING

- AC Input voltage range:
230 ~ 240 Vac
 - Frequency: 50/60 Hz
 - To avoid electrical shock connect the protective grounding conductor of the AC power cord to an earth ground.
-

Cleaning the ASR-002

- Disconnect permanently connected power input before cleaning.
 - Use a soft cloth dampened in a solution of mild detergent and water. Do not spray any liquid.
 - Do not use chemicals containing harsh material such as benzene, toluene, xylene, and acetone.
-

- Operation Environment
- Location: Indoor, no direct sunlight, dust free, almost non-conductive pollution (Note below)
 - Relative Humidity: 20%~ 80%, no condensation
 - Altitude: < 2000m
 - Temperature: 0°C to 40°C
-

- Storage environment
- Location: Indoor
 - Temperature: -10°C to 70°C
 - Relative Humidity: ≤90%, no condensation
-

- Disposal
- 
- Do not dispose this instrument as unsorted municipal waste. Please use a separate collection facility or contact the supplier from which this instrument was purchased. Please make sure discarded electrical waste is properly recycled to reduce environmental impact.
-

Certification of Compliance

The product is in conformity with the directive: EN 61010-1 / EN 61326-1 / WEEE / RoHS

G E T T I N G S T A R T E D

This chapter describes the ASR-002 power controller in a nutshell, including its main features and front/rear panel introduction.

ASR-002 Overview	7
Front Panel	8
Rear Panel	10

ASR-002 Overview

ASR-002, which is a three-phase power controller, is able to control up to 3 single phase power supply units (ASR series only).

It effectively makes AC output conformed to 1P3W/3P4W that generally unit requires, and also turns output into 3P3W via designated wire method.

When the select single phase power is greater than the capacity of 2kVA, it is suggested that output should be connected to external terminal for safety consideration.

Front Panel

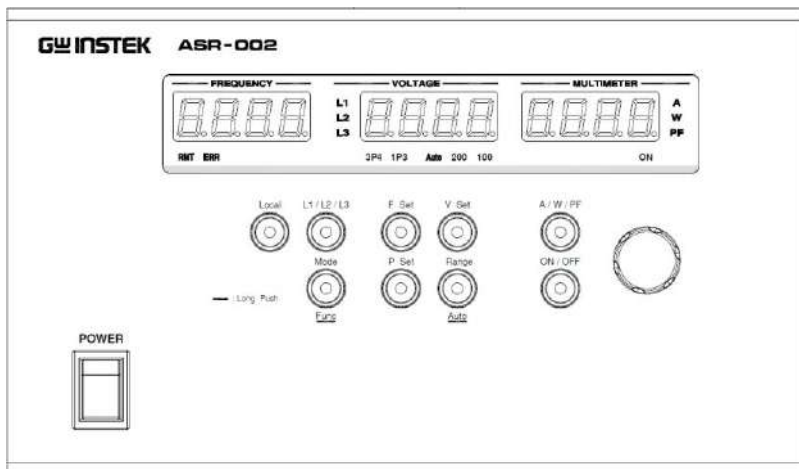

Section	Figure	Description
Header Displays		FREQUENCY: It displays frequency.
		VOLTAGE: It displays voltage.
		MULTIMETER: It displays A current / W power / PF power factor.

Function Keys		It changes header display A → W → PF.
		ON: Output on. OFF: Output off.



Note

It can be operated when connected to ASR series only.



V Set: It configures voltage.



Range: It toggles between 100V and 200V.

Auto: It enters Auto range by long press.



F Set: It configures frequency.



P Set: It configures L2 / L3 phase.



L1 / L2/ L3: It changes among L1 → L2 → L3.



Mode: It toggles between 1P3W → 3P4W.

Func: It configures advance setting by long press.



Local: It cancels connection and enters the local operation mode.



Knob Key: It adjusts value by scroll. Also, it switches input adjustment position by press.

Display Icons



It indicates remote control mode.



It indicates that error of control occurs.



It indicates output phase.

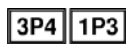

It indicates output mode.







It indicates output range.

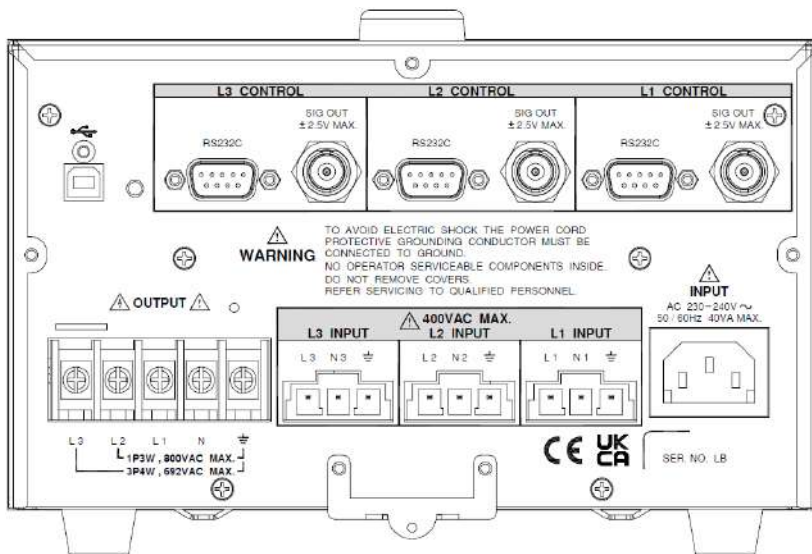

It indicates measurement unit display.

Rear Panel



Section	Figure	Description
USB Port		USB B-type port for remote control.
RS232C Port		RS232C port for remote control.
SIG OUT		SIG OUT for phase control signal output.
Phase Terminal		The phase terminals for L1/L2/L3. Warning: Input Voltage 400VAC Max.

Output Terminal



1P3W: Single phase 3 wire.

Warning: Output Voltage 800VAC Max.

3P4W: Three phase 4 wire.

Warning: Output Voltage 692VAC Max.

Power Voltage
Input

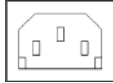

Voltage Input: AC 230~240V.

Power Frequency: 47 – 63Hz.

OPERATION

Basic Operation.....	13
Output Mode Setting Process.....	13
Voltage Range Setting Process.....	13
Voltage Value Setting Process	13
Frequency Setting Process	14
Phase Shift Setting Process.....	14
Advance Setting.....	15
Voltage Amplification Setting Process	15
Slew Rate Setting Process	15
RS232 Baudrate Setting Process	16
Factory Default Setting Process	16
Phase Angle Setting.....	17
Phase Angle Setting Process	17
Voltage Ramp Setting	18
Voltage Ramp Setting Process	18
Frequency Sweep Setting	19
Frequency Sweep Setting Process	19
Unit Setting Value Display	20
Unit Setting Value Display Setting Process	20
Factory Default Settings	21
Wire Connection & Accessories	23
Accessories	24

Basic Operation

Output Mode Setting Process

- Steps
1. Press the Mode key.
 2. Toggle between 1P3W → 3P4W.

Voltage Range Setting Process

- Steps
1. Press the Range key.
 2. Toggle between 100V → 200V.
Press and hold the Range key to enter Auto.

Voltage Value Setting Process

- Steps
1. Press the V Set key.
 2. Scroll the Knob key to adjust voltage value.
 3. 100V: 0 – 175V
200V: 0 – 350 V
Auto: 0 – 350V
 4. After adjustment, press the V Set key again to upload the set value to ASR series unit.

Frequency Setting Process

- Steps
1. Press the F Set key.
 2. Scroll the Knob key to adjust frequency value.
 3. Frequency range: 40 – 999.9Hz.

Phase Shift Setting Process

- Steps
1. Press the P Set key.
 2. Scroll the Knob key to adjust phase.
 3. Press the P Set key to enter the next step.

L2 setting range: 85° - 155° P5E4 1200 000

L3 setting range: 205° - 275° P5E4 2400 000

4. Press the P Set key to exit.

Advance Setting

Voltage Amplification Setting Process

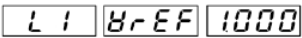
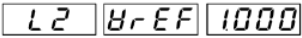
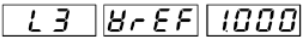
- Steps
1. Press and hold the Mode key to enter the setting.
 2. Adjust L1/L2/L3 based on voltage amplification.
 3. Scroll the Knob key to adjust amplification. The setting range: 0 - 3.5.

Press L1/L2/L3 key to enter next step.

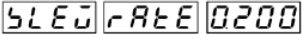
 4. After configuration, press the Range key to enter the next step.

Slew Rate Setting Process

- Steps
1. Slew Rate setting. Setting 
range: 0.001 - 0.5.
 2. After configuration, press the Range key to enter the next step.

RS232 Baudrate Setting Process

- Steps
1. RS232 interface transmission speed setting (9600 by default).
Setting range: (9600 → 19200 → 38400 → 57600 → 115200).
- `baud` `9600`

Factory Default Setting Process

- Steps
1. Restore to the factory default setting. Press the Range key, and the system exits automatically.
- `FACT` `DEF`

Phase Angle Setting

Phase Angle Setting Process

- Steps
1. Press and hold the P Set key to enter the phase angle setting.
 2. Set the starting angle.
 3. The default setting is OFF. on PHAS OFF
 4. Press the Range key to enter next step or scroll the Knob key to adjust to ON for angle setting. The setting range: 0° - 359°. on PHAS on
 5. Press the Range key to enter the next step and exit from starting angle setting.
 6. Set the ending angle.
 7. The default setting is OFF. OFF PHAS OFF
 8. Press the Range key to finish phase angle setting or scroll the Knob key to adjust to ON for angle setting. The setting range: 0° - 359°. OFF PHAS on
 9. After configuration, press the Range key to finish phase angle setting.

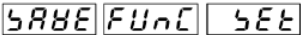
10. Press and hold the Mode key and display will be shown as the right figure.

11. Press the Range key to save the setting and exit.

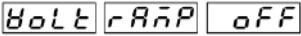
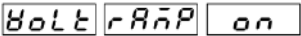
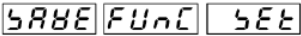

Voltage Ramp Setting

Voltage Ramp Setting Process

- | | |
|-------|---|
| Steps | <ol style="list-style-type: none">1. Press and hold the V Set key to enter the Ramp setting.2. The default setting is OFF. 3. Press the Range key to exit from Ramp setting or scroll the Knob key to Ramp ON followed by pressing Range key to enter the Ramp value setting.
4. The setting range: 0.001 – 9.9995. Press the Range key to exit.6. Press and hold the Mode key and display will be shown as the right figure.
7. Press the Range key to save the setting and exit. |
|-------|---|

Frequency Sweep Setting

Frequency Sweep Setting Process

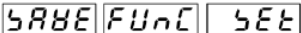
- Steps
1. Press and hold the F Set key to enter the Sweep setting.
 2. The default setting is OFF. 
 3. Scroll the Knob key to Sweep ON followed by pressing the Range key to enter the Sweep value setting. 
 4. The setting range: 0.001 – 9.999
 5. Press the Range key to exit.
 6. Press and hold the Mode key and display will be shown as the right figure. 
 7. Press the Range key to save the setting and exit.

Unit Setting Value Display

Unit Setting Value Display Setting Process

- Steps
1. Press and hold the Mode key to enter the setting.
 2. Press the L1/L2/L3 key or the Mode key to browse the default settings as follows.

L1 Vref 1.000 L1 VrEF 1000

L2 Vref 1.000 L2 VrEF 1000

L3 Vref 1.000 L3 VrEF 1000

SLEW RATE 0.200 SLEW RATE 0200

BAUD 9600 bAUD 9600

FACT DEFA FACT dEFA

SOFT VER T101 sOFT VER t101

SAVE FUNC SET sAVE FuNC sEt

EXT ASR SET EtE ASr sEt

EXIT FUNC SET EtEtE FuNC sEt

Factory Default Settings

The following default settings are the factory configuration settings for the ASR-002 series. For details on how to return to the factory default settings, please see the page 16.

Basic operation	ASR-002	Display
Output Mode Setting	3P4W	<p style="text-align: center;">———— VOLTAGE ————</p> <p style="text-align: center;">3P4W 1P3W Auto 200 100</p>
Voltage Range Setting	100	
Voltage Value Setting	0.0	
Frequency Setting	50.00	<p style="text-align: center;">———— FREQUENCY ————</p> <p style="text-align: center;">RMT ERR</p>
Phase Shift Setting	(L2)Pset 120.0	<div style="display: flex; justify-content: space-around;"> <div style="text-align: center;"> <p>———— FREQUENCY ————</p> <p style="text-align: center;">RMT ERR</p> </div> <div style="text-align: center;"> <p>———— VOLTAGE ————</p> <p style="text-align: center;">3P4W 1P3W Auto 200 100</p> </div> </div>
	(L3)Pset 240.0	<div style="display: flex; justify-content: space-around;"> <div style="text-align: center;"> <p>———— FREQUENCY ————</p> <p style="text-align: center;">RMT ERR</p> </div> <div style="text-align: center;"> <p>———— VOLTAGE ————</p> <p style="text-align: center;">3P4W 1P3W Auto 200 100</p> </div> </div>

Advance Setting	ASR-002	Display
Voltage Amplification Setting	L1 Vref 1.000	
	L2 Vref 1.000	
	L3 Vref 1.000	
Slew Rate Setting	Slew rate 0.2	
RS232 Baudrate Setting	Baud 9600	
Phase Angle Setting	On phase off	
	Off phase off	
Voltage Ramp Setting	Voltage ramp off	
Frequency Sweep Setting	Frequency sweep off	

Wire Connection & Accessories

Three-Phase Wire Connection Image ($\leq 2kVA$)

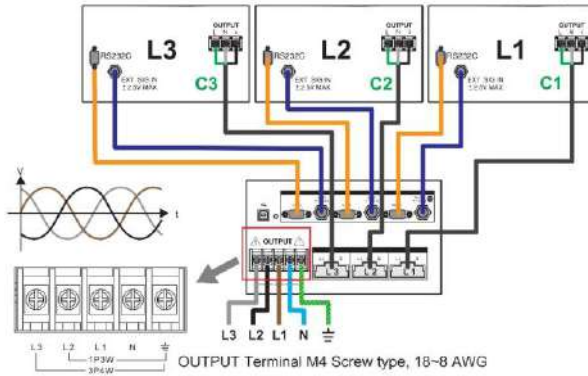

Three-Phase Wire Connection Image ($> 2kVA$)

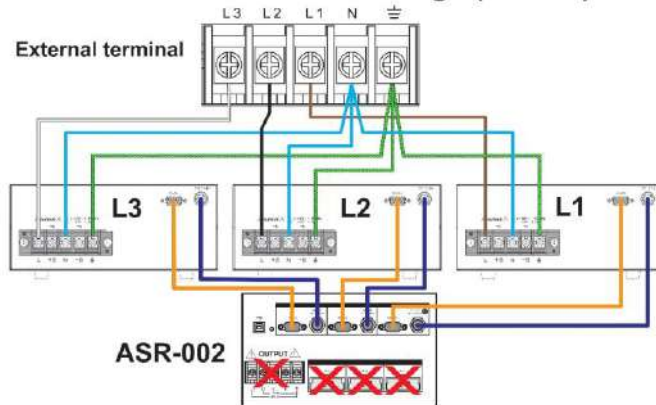

 **Note**

Only the identical series models can be utilized simultaneously. That is, ASR-2000 series and ASR-3000 series are Not available to be used at the same time.

Accessories

Part Number	Description
GTL-232 x 3	RS232C cable, approx. 2m
GTL-110 x 3	BNC test lead, approx 1.1m
GTL-246 x 1	USB Cable (USB 2.0 Type A- Type B Cable, Approx. 1.2m)
40WC792030011 x 3	C1/C2/C3 Cable, 7m Max Length, UL1015 12AWG, RV5-5, Hirose DF22-4S-7.92C(28) 3P + DF22A-1012SCFA

APPENDIX

ASR-002 Dimension.....	25
Using the Rack Mount Kit.....	26
Command List.....	28
ASR-002 Error Messages	29

ASR-002 Dimension

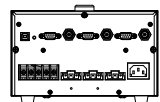
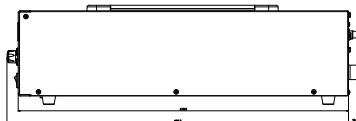
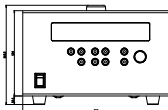
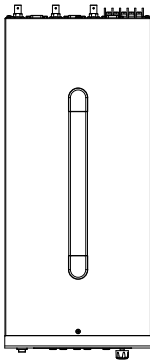

Using the Rack Mount Kit

Background

The ASR-002 assembled with ASR-2000 or ASR-3000 has the following optional Rack Mount kits.

ASR-002 with ASR-2000R assembled with rack EIA

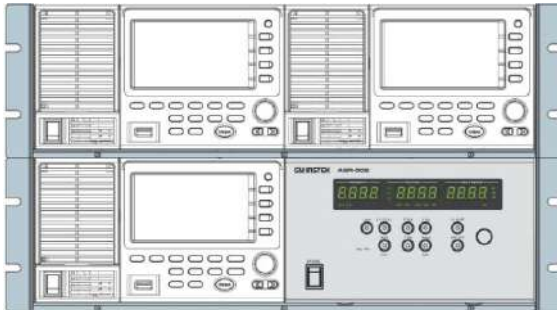

ASR-002 with ASR-2000 assembled with rack EIA

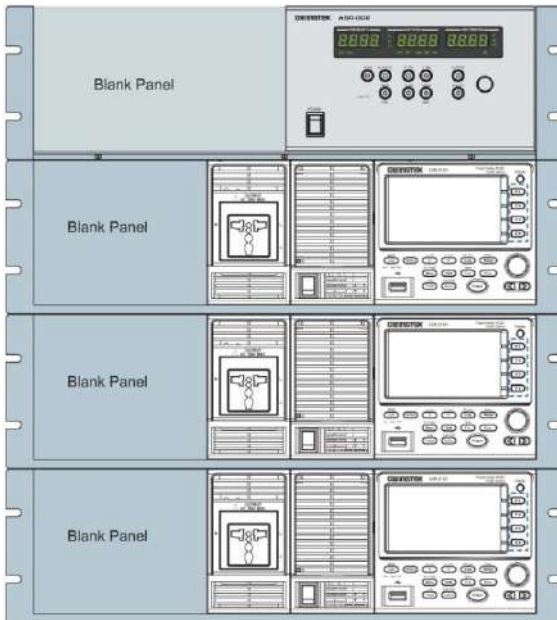

ASR-002 with
ASR-3000
assembled with
rack EIA

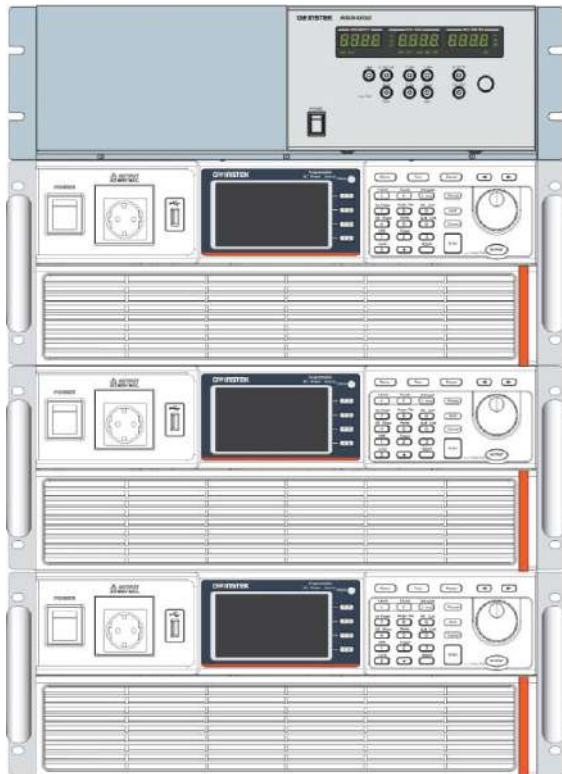

Command List

Source Commands	[SOURCE:]VOLTage[:LEVel][:IMMediate][:AMPLitude] [SOURCE:]VOLTage[:LEVel][:IMMediate][:AMPLitude]? [SOURCE:]VOLTage:RANge 100/200/AUTO [SOURCE:]VOLTage:RANge? [SOURCE:]VOLTage:MODE FIXed/STEP [SOURCE:]VOLTage:MODE? [SOURCE:]VOLTage:SLEW xxx [SOURCE:]VOLTage:SLEW? [SOURCE:]FUNction[:SHAPE][:IMMediate] SIN/SQU/TRI [SOURCE:]FUNction[:SHAPE][:IMMediate]? [SOURCE:]FREquency[:IMMediate] xxx [SOURCE:]FREquency[:IMMediate]? [SOURCE:]PHASe:PHASe L12,xxx/L13,xxx [SOURCE:]PHASe:PHASe? L12/L13 [SOURCE:]PHASe:STARt:ENABle ON/OFF/1/0 [SOURCE:]PHASe:STARt:ENABle? [SOURCE:]PHASe:STARt xxx [SOURCE:]PHASe:STARt? [SOURCE:]PHASe:STOP:ENABle ON/OFF/1/0 [SOURCE:]PHASe:STOP:ENABle? [SOURCE:]PHASe:STOP xxx [SOURCE:]PHASe:STARt?
Output Commands	OUTPut[:STATe] ON/OFF/1/0 OUTPut[:STATe]?
Display Commands	DISPlay[:WINDow]:INSTrument:NSElect 0/1/2 DISPlay[:WINDow]:INSTrument:SElect L1/L2/L3
Measure Commands	MEASure[:SCALar]:FREquency? MEASure[:SCALar]:CURRent[:RMS]? MEASure[:SCALar]:CURRent:AVErage? MEASure[:SCALar]:VOLTage[:RMS]? MEASure[:SCALar]:VOLTage:AVErage? MEASure[:SCALar]:POWer[:AC][:REAL]? MEASure[:SCALar]:POWer[:AC]:APParent? MEASure[:SCALar]:POWer[:AC]:REACtive? MEASure[:SCALar]:POWer[:AC]:PFActor?
System Commands	SYSTem:ERRor? SYSTem:CONFigure:NPU 3P4W/1P3W SYSTem:CONFigure:NPU?
Common Commands	*IDN? *CLS *RST

ASR-002 Error Messages

The following error messages may appear on the ASR-002 screen display during varied operations.

Section	Error Messages
	0 "No error"
	-101 "Invalid character"
	-102 "Syntax error"
	-103 "Invalid separator"
Command Error	-108 "Parameter not allowed"
	-109 "Missing parameter"
	-113 "Undefined header"
	-121 "Invalid character in number"
	-148 "Character data not allowed"
	-151 "Invalid string data"

Section	Error Messages
	-203 "Command protected"
Execution Error	-222 "Data out of range"
	-224 "Illegal parameter value"

Section	Error Messages
Device Specific Error	-330 "Self-test failed"
	-350 "Error queue overflow"

Section	Error Messages
	-410 "Query INTERRUPTED"
Query Error	-420 "Query UNTERMINATED"
	-521 "Input buffer overflow"
	-522 "Output buffer overflow"