

Multi-output DC Power Supply

GPE-1326A /2323A /3323A /4323A Series

USER MANUAL

GW INSTEK PART NO. 82GP34323A301



ISO-9001 CERTIFIED MANUFACTURER

GW INSTEK

This manual contains proprietary information, which is protected by copyrights. All rights are reserved. No part of this manual may be photocopied, reproduced or translated to another language without prior written consent of Good Will company.

The information in this manual was correct at the time of printing. However, Good Will continues to improve products and reserves the rights to change specification, equipment, and maintenance procedures at any time without notice.

Table of Contents

SAFETY INSTRUCTIONS	6
OVERVIEW	10
Introduction.....	10
Main Features	13
Principle of Operation.....	14
Front Panel Overview	16
Rear Panel Overview	23
CV/CC Crossover Characteristics	24
SETUP	25
Power Up	25
Load Cable Connection	26
Output On/Off.....	27
Select CH1/CH2 series or parallel mode	27
Switch between Channels.....	28
Setting Voltage Lock from Front Panel .	29
Set the output state at startup	29
Set the displayed digit resolution for the voltage/current	30
Remote Control Setting.....	31
OPERATION	32
CH1/CH2 Independent Mode	32
CH3 Independent Mode.....	34
CH4 Independent Mode.....	36
CH1/CH2 Series Tracking Mode.....	38
CH1/CH2 Parallel Tracking Mode.....	43
FAQ	45

APPENDIX	46
Fuse Replacement.....	46
Specifications	47
Declaration of Conformity.....	50

S SAFETY INSTRUCTIONS

This chapter contains important safety instructions that you must follow when operating the GPE series and when keeping it in storage. Read the following before any operation to insure your safety and to keep the best condition.

Safety Symbols

These safety symbols may appear in this manual or on the GPE.



Warning: Identifies conditions or practices that could result in injury or loss of life.



Caution: Identifies conditions or practices that could result in damage to the GPE.



DANGER High Voltage



Attention Refer to the Manual



Protective Conductor Terminal



Earth (ground) Terminal



Do not dispose electronic equipment as unsorted municipal waste. Please use a separate collection facility or contact the supplier from which this instrument was purchased.

SAFETY INSTRUCTIONS

Safety Guidelines

General Guidelines



CAUTION

- Do not place any heavy object on the device.
 - Avoid severe impacts or rough handling that leads to damaging the device.
 - Do not discharge static electricity to the device.
 - Do not block or obstruct the cooling fan vent opening.
 - Do not perform measurement at circuits directly connected to Mains.
 - Do not disassemble the device unless you are qualified as service personnel.
-

Power Supply



WARNING

- AC Input voltage:
100 V / 120 V / 220 V \pm 10 %, 230 VAC +10 % / -6 %, 50 Hz or 60Hz
 - Connect the protective grounding conductor of the AC power cord to an earth ground, to avoid electrical shock.
-

Fuse



WARNING

- Fuse type:
100 V / 120 V: T 6.3 A / 250 V
220 V / 230 V: T 3.15 A / 250 V
 - Make sure the correct type of fuse is installed before power up.
 - To ensure fire protection, replace the fuse only with the specified type and rating.
 - Disconnect the power cord before fuse replacement.
 - Make sure the cause of fuse blowout is fixed before fuse replacement.
-

- Cleaning the device
- Disconnect the power cord before cleaning.
 - Use a soft cloth dampened in a solution of mild detergent and water. Do not spray any liquid.
 - Do not use chemicals or cleaners containing harsh products such as benzene, toluene, xylene, and acetone.
-

- Operation Environment
- Location: Indoor, no direct sunlight, dust free, almost non-conductive pollution (note below)
 - Relative Humidity: < 80 %
 - Altitude: < 2000 m
 - Temperature: 0 °C to 40 °C
-

(Pollution Degree) EN 61010-1:2010 specifies the pollution degrees and their requirements as follows. The GPE series falls under degree 2.

Pollution refers to “addition of foreign matter, solid, liquid, or gaseous (ionized gases), that may produce a reduction of dielectric strength or surface resistivity”.

- Pollution degree 1: No pollution or only dry, non-conductive pollution occurs. The pollution has no influence.
 - Pollution degree 2: Normally only non-conductive pollution occurs. Occasionally, however, a temporary conductivity caused by condensation must be expected.
 - Pollution degree 3: Conductive pollution occurs, or dry, non-conductive pollution occurs which becomes conductive due to condensation which is expected. In such conditions, equipment is normally protected against exposure to direct sunlight, precipitation, and full wind pressure, but neither temperature nor humidity is controlled.
-

- Storage environment
- Location: Indoor
 - Relative Humidity: < 70 %
 - Temperature: -10 °C to 70 °C
-

Disposal



Do not dispose this instrument as unsorted municipal waste. Please use a separate collection facility or contact the supplier from which this instrument was purchased. Please make sure discarded electrical waste is properly recycled to reduce environmental impact.

OVERVIEW

This chapter describes the GPE series in a nutshell, including its main features and front/ rear panel introduction. After going through the overview, follow the Setup chapter (page 25) to properly power up and set operation environment.

Introduction

Overview

The GPE-1326A/2323A/3323A/4323A series regulated DC power supply series are light weight, adjustable, multifunctional work stations.

The GPE-1326A has a single independent adjustable voltage output. The remote voltage compensation function is activated for large changes in current output.

The GPE-2323A has a 2 independent adjustable voltage outputs.

The GPE-3323A has three independent outputs: two with adjustable voltage levels and one with fixed level 5 V.

The GPE-4323A has four independent voltage outputs that are all fully adjustable.

The series can be used for logic circuits where various output voltage or current are needed, and for tracking mode definition systems where plus and minus voltages with insignificant error are required.

OVERVIEW

Independent / Series Tracking / Parallel Tracking The three output modes of GPE-2323A/3323A / 4323A series, independent, series tracking and parallel tracking can be selected through pressing the TRACKING key on the front panel.

In the independent mode, the output voltage and current of each channel are controlled separately.

In the tracking modes, both the CH1 and CH2 outputs are automatically connected in series or parallel. CH1 is master and CH2 is slave; no need to connect output leads.

In the series mode, the output voltage is doubled;

In the parallel mode, the output current is doubled.

The isolation degree, from output terminal to chassis or from output terminal to output terminal, is 500 V.

Constant Voltage/ Constant Current Each output channel works in constant voltage (CV) or constant current (CC) mode. Even at the maximum output current, a fully rated, continuously adjustable output voltage is provided.

For a big load, the power supply can be used as a CV source; while for a small load, a CC source.

When in the CV mode (independent or tracking mode), output current (overload or short circuit) can be controlled via the front panel. When in the CC mode (independent mode only), the maximum (ceiling) output voltage can be controlled via the front panel.

The power supply will automatically cross over from CV to CC operation when the output current reaches the target value. The power supply will automatically cross over from CC to CV when the output voltage reaches the target value.

For more details about CV/CC mode operation, see page [24](#).

Automatic tracking mode

The front panel display (CH1, CH2) shows the output voltage or current. When operating in the tracking mode, the power supply will automatically connect to the auto-tracking mode. For more details about CH1/CH2 Series Tracking Mode, see page [38](#)

Main Features

Performance	<ul style="list-style-type: none">• Low noise: Temperature controlled cooling fan• Compact size, light weight
Operation	<ul style="list-style-type: none">• Constant Voltage / Constant Current operation• Series Tracking / Parallel Tracking operation• Output On/Off control• Multi-output: GPE-1326A: 32 V / 6 A x 1; GPE-2323A: 32 V / 3 A x 2; GPE-3323A: 32 V / 3 A x 2, 5 V / 5 A x 1; GPE-4323A: 32 V / 3 A x 2, 5 V / 1 A x 1, 15 V / 1 A x 1• Output voltage compensation control (GPE-1326A)• Output voltage/ current setting view• Set the displayed digit resolution for the voltage & current output.
Protection	<ul style="list-style-type: none">• Overload protection• Key misoperation protection (lock)• Reverse polarity protection
Interface	<ul style="list-style-type: none">• Remote control (Output ON/OFF)

Principle of Operation

- Overview The power supply consists of the following.
- AC input circuit
 - Transformer
 - Bias power supply including rectifier, filter, pre-regulator and reference voltage source
 - Main regulator circuit including the main rectifier and filter, series regulator, current comparator, voltage comparator, reference voltage amplifier, remote device and relay control circuit

The block diagram below shows the CH1 circuit arrangement. The single phase input power is connected to the transformer through the input circuit. Details of each part are described in the next page.

Block diagram

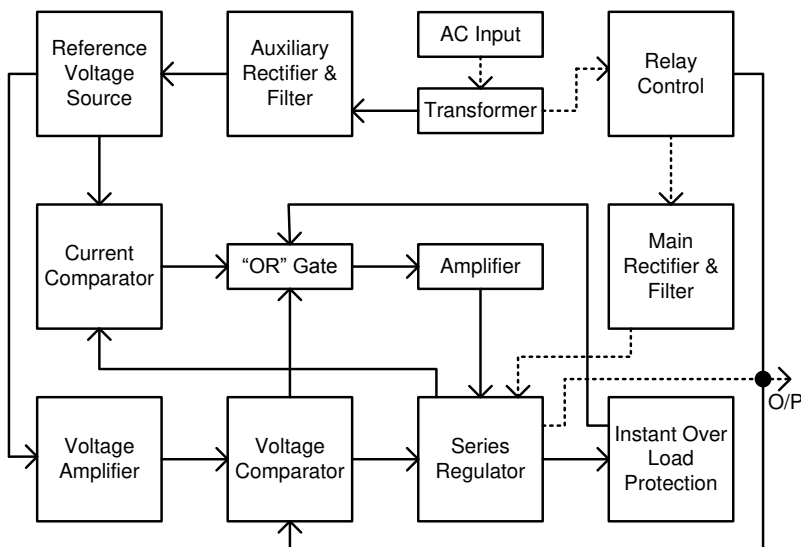

OVERVIEW

Auxiliary Rectifier The auxiliary rectifiers D120 to D123 provide bias voltage filtered by the capacitors C120 and C121, for the pre-regulators U150 and U151. They provide a regulated voltage for other modules.

Main Rectifier The main rectifier is a full wave bridge rectifier. It provides the power after the rectifier is filtered by the capacitor C101, and then regulated via a series-wound regulator, which is finally delivered to the output terminal.

Current Limiter U151 is a comparator amplifier which compares the reference voltage to the feedback voltage, and then delivers it to Q151, which then calibrates the output voltage.

Overvoltage U131 is a comparator which activates when the unit is overloaded and it controls the output of U132 to turn off the output and inform the user.

Front Panel Overview

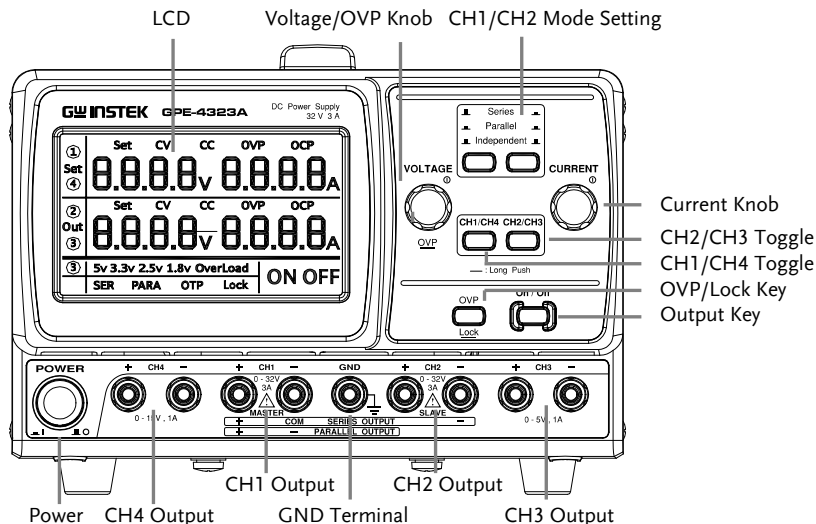

The figure above is the front view of the GPE-4323A. For views of other models, please refer to physical device or see the panel overview for the other models on page 22.

Display

CH1/CH4 parameter display area (parameter settings for the GPE-1326A)



CH2/CH3 parameter display area (parameter readings for the GPE-1326A)



OVERVIEW

CH3 parameter display area for the GPE-3323A

③ | 5v OverLoad

Status display area

SER PARA OTP Lock

Output status display

ON OFF

Voltmeter Displays output voltage of each channel.
GPE-4323A: CH1/CH4 and CH2/CH3
GPE-2323A/3323A: CH1 and CH2
GPE-1326A: Voltage setting/readback

3 digits: 0.0.0v

4 digits: 0.0.0.0v

CH3 display: 5v
(GPE-3323A)

Ammeter Displays output current of each channel.
GPE-4323A: CH1/CH4 and CH2/CH3
GPE-2323A/3323A: CH1 and CH2
GPE-1326A: Current setting/readback

3 digits: 0.0.0A

4 digits: 0.0.0.0A

<p>CV/CC/OVP indicators (Excluding CH3 of 3323)</p>	<p>CV CC</p>	<p>According to the selected channel (displayed on the left side of the LCD as ①②③④), the CV/CC status of the corresponding channel can be viewed. This status is only valid when the output is ON, and it is displayed as OFF when the output is OFF.</p> <p>When OVP is enabled, it is displayed in white, and when not enabled, it is not displayed. After startup, the OVP font flashes.</p>
<p>View setting value (Excluding CH3 of 3323)</p>	<p>Set</p>	<p>When the channel output is OFF, it displays as the set value; When ON, it is displayed as a read back value, and when there is a set operation, it is displayed as a set value. The status bar also shows Set.</p>
<p>Channel indicator</p>	<p>①②③④</p>	<p>Indicates the currently selected channel.</p>
<p>Output status of CH3 in the GPE-3323A</p>	<p>OverLoad</p>	<p>When the output current is over range, the overloaded indicator OverLoad will be lit on the LCD display.</p>

OVERVIEW

Control Panel

Channel parameter setting

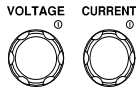

Voltage/current value setting: When rotating clockwise, the value increases, and when rotating counterclockwise, the value decreases.

Click the Encode to enter the position setting.

Automatically confirm and exit the set state after stopping the operation for a few seconds.



OVP: Long press the Encode to enter the OVP setting. When rotating clockwise, the value increases, and when rotating counterclockwise, the value decreases.

Click the Encode to enter the position setting.

Automatically confirm and exit the set state after stopping the operation for a few seconds.

CH1/4 and CH2/3 Display switching



Views the channel settings or readback values for GPE-4323A voltage/current/OVP. Press the CH1/4 or CH2/3 key to toggle the view for the corresponding channels in the display.

Parallel/Series Keys

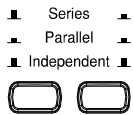

Activates parallel/series tracking operation. For details, see page 38. The corresponding channel will be displayed on the LCD display. The GPE-1326A doesn't have this function.

Enable/disable
OVP, Key lock



Click this button to enable or disable the OVP function, as shown in the status bar display;
When the lock function is activated for a long time, it can lock or unlock the operation of panel buttons (except for series parallel operation and output key function), and the status bar displays it. For more information, please refer to page 29.

Output Key



Turns the output on or off. For more details, see page 27.

Power Switch



Turns On or Off the main power. For the power up sequence, see page 25.

Terminals

GND Terminal



Accepts a grounding wire.

CH1 Output

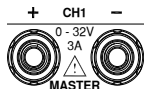

Outputs CH1 voltage and current.

CH2 Output

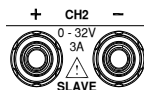

Outputs CH2 voltage and current.

CH3 Output

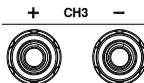

Outputs CH3 voltage and current.

CH4 Output

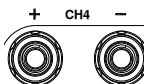

Outputs CH4 voltage and current.

OVERVIEW

The GPE-1326 A $\frac{+}{-}$ $\frac{-}{-}$ Output voltage and current
Output



The GPE-1326A $\frac{s+}{-}$ $\frac{s-}{-}$ Remote sense terminals
Sense



Front views of the other three models:

GPE-1326A

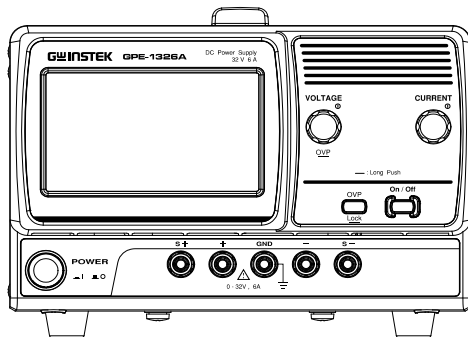

GPE-2323A

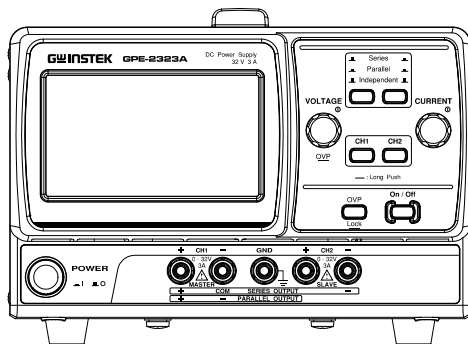

GPE-3323A

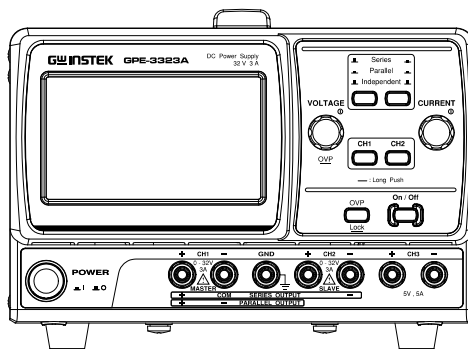

Rear Panel Overview

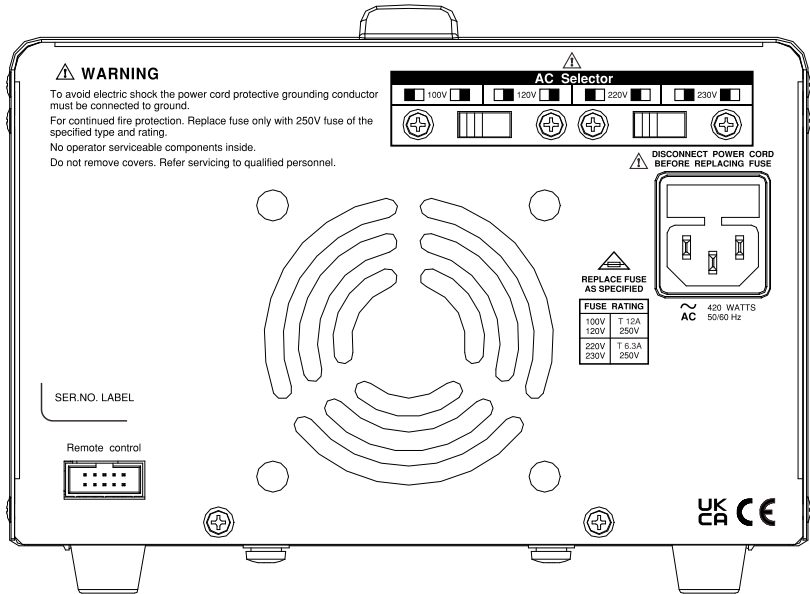

Remote Control Terminal



For more information about the remote control terminal, please see page 31.

Power Cord / Fuse Socket

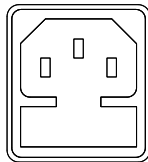

The power cord socket accepts the AC mains. For power up details, see page 25.

The fuse holder contains the AC mains fuse. For fuse replacement details, see page 46.

AC Selector

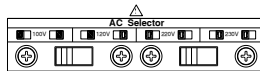

Selects AC input voltage: 100 V / 120 V / 220 V / 230 V; 50 Hz to 60 Hz.

CV/CC Crossover Characteristics

Background The GPE series automatically switch between constant voltage mode (CV) and constant current mode (CC), according to load condition.

CV mode When the current level is smaller than the output setting, the GPE operates in Constant Voltage mode. The indicator for the corresponding channel appears on the LCD.

The Voltage level is kept at the setting and the Current level fluctuates according to the load condition until it reaches the output current setting.

CC mode When the current level reaches the output setting, the GPE starts operating in Constant Current mode. The indicator for the corresponding channel appears on the LCD.

The Current level is kept at the setting but the Voltage level becomes lower than the setting, in order to suppress the output power level from overload. When the current level becomes lower than the setting, the GPE goes back to the Constant Voltage mode.

Diagram

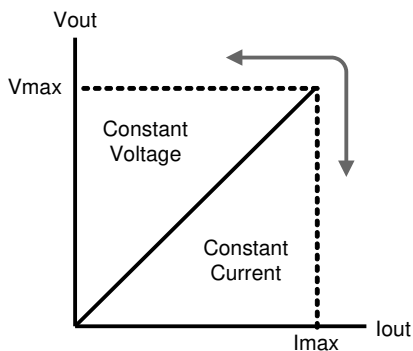

SETUP

This chapter describes how to properly power up and configure the GPE series before operation.

Power Up

Select AC voltage Before powering up the power supply, select the AC input voltage from the rear panel.

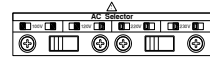

Connect AC power cord Connect the AC power cord to the rear panel socket.

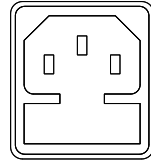

Power On Press the power switch to turn on the power. The display will first display all the LCD segments before showing settings for each channel.



Power Off Press the power switch again to turn off the power.



Load Cable Connection

Standard accessories (GTL-104A, GTL-105A)

1. Turn the terminal counterclockwise and loosen the screw.
2. Insert the cable terminal.
3. Turn the terminal clockwise and tighten the screw.

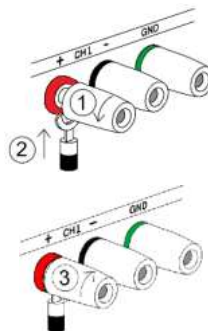

Banana plug

Insert the plug into the socket.

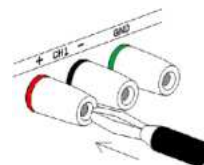

Wire type

When using load cables other than the attached, make sure they have enough current capacity for minimizing cable loss and load line impedance. Voltage drop across a wire should not exceed 0.5 V. The following list is the wire current rating at 450 A/cm².

Wire size (AWG)	Maximum current (A)
20	2.5
18	4
16	6
14	10
12	16

Output On/Off

Panel operation Press the Output key to turn on all outputs in each channel. The **ON** icon will become lit on the LCD display.



Push the Output key again to turn off all outputs. The **OFF** icon will become lit on the LCD display.



Automatic output off Any of the following actions during output on automatically turns it off.





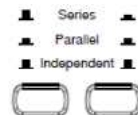

- Change the operation mode between independent / series tracking / parallel tracking
- When a single channel OVP is started, the corresponding output will be turned off. When CH1/CH2 is started simultaneously, all channels will be closed together.

Select CH1/CH2 series or parallel mode

Background / Connection When you need to output a higher voltage or current through the GPE-2323A/3323A/4323A series can be connected in series or parallel to achieve it. When connecting in series, the output voltage is twice than that of a single channel. When connecting in parallel, the output current is twice than that of a single channel. For details, please see page 38.

Panel operation You can toggle the connection mode of CH1/ CH2 by using different combinations of the mode selection key.



- For the independent mode, the right key is not pressed  Independent 
- Toggle to parallel mode when both keys are pressed.  Parallel 
- Right key is pressed and the left key is not pressed in series mode.  Series 

When CH1 / CH2 is in the series or parallel mode, the corresponding series or parallel icon appears on the LCD display.

SER PARA

Switch between Channels

Background / Connection This feature is only available for the GPE-4323A. The voltage and current settings and readback values for 2 channels can be displayed on the LCD display simultaneously. To check and view the relevant information for the other channels, you need to switch channels. Please follow the steps listed below to switch between channels.

Panel operation Press the CH1/4 key to toggle between CH1 and CH4. The activated channel will be shown on the channel indicator.

CH1/CH4



Press the CH2/3 key to toggle between CH2 and CH3. The activated channel will be shown on the channel indicator.

CH2/CH3



Setting Voltage Lock from Front Panel

Background / Connection When using the GPE series, if it is necessary to keep the set output value unchanged to avoid damage to the load due to misoperation, a locking operation can be performed.

Panel operation Press the LOCK key (for more than 2 seconds) to lock the key operation. At the same time, the word "Lock" is displayed on the LCD.



To unlock, press the LOCK key for more than 2 seconds. The **Lock** icon will then turn off.



- The OUTPUT key is not affected by the lock operation.
- Series parallel operation is not controlled by the lock key.

Set the output state at startup

Background / Connection Through the following steps, you can set the output state of the GPE series at its next startup. There are two choices, ON and OFF available for selection.

Panel operation

1. Press and hold the Output key and turn on the power until the **ON** or **OFF** icon flashes on the LCD display.



2. Press the "OVP" key to select.



3. Press the "ON/OFF" key to confirm.





Note

By default the output is set to OFF at startup.

Set the displayed digit resolution for the voltage/current

Background /
Connection

The GPE series can set the displayed digit resolution for the voltage and current settings/readings to 3 or 4 digits at startup.

Panel operation

1. Press and hold the "OVP" key and turn the power until on the decimal point for the CH1 voltage flashes on the LCD display.



2. Press the "OVP" key to select the number of displayed digits.



3. Press the "ON/OFF" key to confirm the selection.



Note

By default the number of displayed digits is set to three.

Remote Control Setting

Background /
Connection

Through the "Remote Control" terminal, the GPE series can turn the power on or off.

Remote control

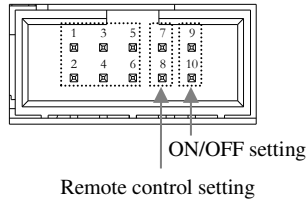

Panel operation

1. Short pins 7 and 8 (remote control setting). This will put the power state (ON/OFF) under remote control.



2. Output control:

- Pin 9 & 10 Open: ON state. At this moment, the **ON** icon flashes on the LCD display.
- Pin 9 & 10 Short: OFF state. At this moment, the **OFF** icon flashes on the LCD display



The remote control terminal can only be controlled by shorting (external relay or jumper shunt) /opening the pins. Voltage cannot be applied to the pins. It is strictly prohibited to short pins 5 & 7 or 6 & 8. Pin 1 to Pin 6 must be set to open.

OPERATION

CH1/CH2 Independent Mode

Background / Connection CH1 and CH2 outputs work independent of each other.

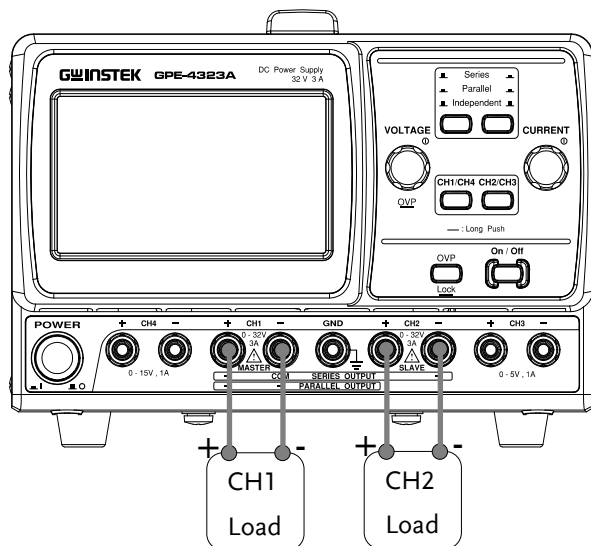

Output rating 0 V to 32 V / 0 V to 3 A for each channel

- Panel operation
1. Make sure the Series/Parallel key is not activated (both the **SER** and **PARA** icons are off). ■ Independent ■

2. Connect the load to the front panel terminals, CH1 +/−, CH2 +/−.

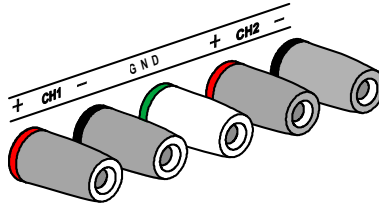

3. Use the knob to set the CH1 output voltage and current.

VOLTAGE CURRENT



4. Use the knob to set the CH2 output voltage and current.

VOLTAGE CURRENT



5. Press the Output key to turn on the output. The Output key will be lit and the **ON** icon will appear on the LCD display. The **CV** or **CC** icon appears on the LCD to indicate the output status for each channel.

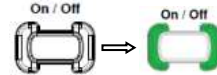

CH3 Independent Mode

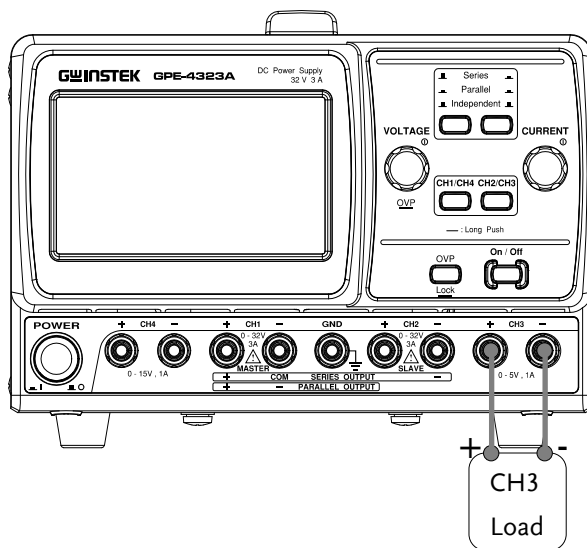

Output rating GPE-3323A : 5 V, 5 A Max
 GPE-4323A : 0 V to 5 V, 1 A Max.

No Series/Parallel Tracking CH3 doesn't have series/parallel tracking mode. Also, the CH3 output is not affected by the CH1 and CH2 modes.

Panel operation 1. Connect the load to the front panel CH3 +/– terminal.

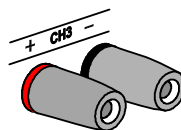

2. Select the output voltage
 For GPE-3323A: 5 V.

OPERATION

For GPE-4323A:

You can check the setting of the GPE-4323A by using the CH2/CH3 key to toggle to CH3 (③ appears on the LCD display).



3. Use the knobs to set the voltage and current.

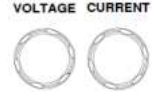

4. Press the Output key to turn on the output. The Output key will be lit.

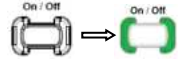

OVERLOAD

GPE-3323A: When the output current level exceeds 5.2 A, the **OverLoad** icon appears on the LCD display and CH3 operation mode switches from constant voltage to constant current.

CV → CC

GPE-4323A: When the output current level exceeds the setting value, the **CV** icon changes to the **CC** icon on the LCD display. This indicates that CH3 has switched from constant voltage to constant current.

CH4 Independent Mode

Background / Connection The mode is used only for the GPE-4323A

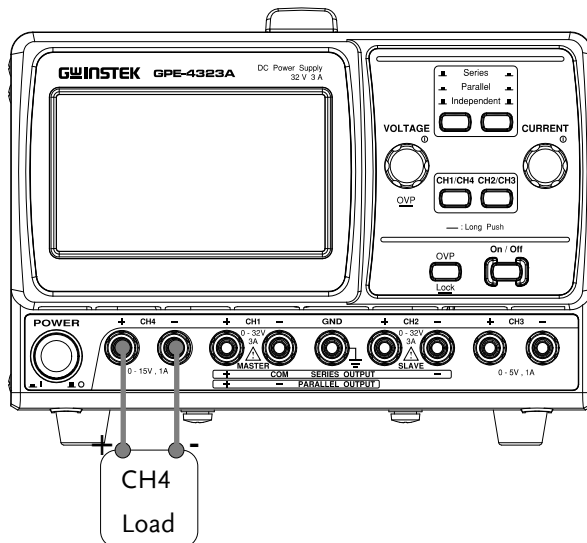

Output rating 0 V to 15 V/1 A max

No Series/Parallel Tracking CH4 doesn't have series/parallel tracking mode. The CH4 output is not affected by the CH1 and CH2 modes.

Panel operation 1. Connect the load to the front panel CH4 +/- terminal.

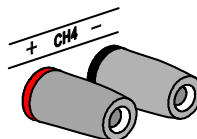

2. You can use the CH1/CH4 key to toggle to CH4 (4 appears on the LCD display).



OPERATION

- Use the knobs to set the voltage and current.

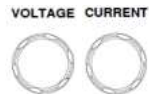

- Press the Output key to turn on the output. The Output key will be lit.

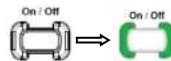

CV → CC

When the output current level exceeds the setting value, the CV icon changes to the CC icon on the LCD display. This indicates that CH4 has switched from constant voltage to constant current.

CH1/CH2 Series Tracking Mode

Background Series tracking operation allows the GPE-2323A/3323A/4323A to combine the output by internally connecting CH1 (Master) and CH2 (Slave) in series. CH1 (Master) controls the combined output voltage/current level which is set independently.

The following describes two types of configurations, depending on how common ground is used.

Series Tracking without Common Terminal

Connection

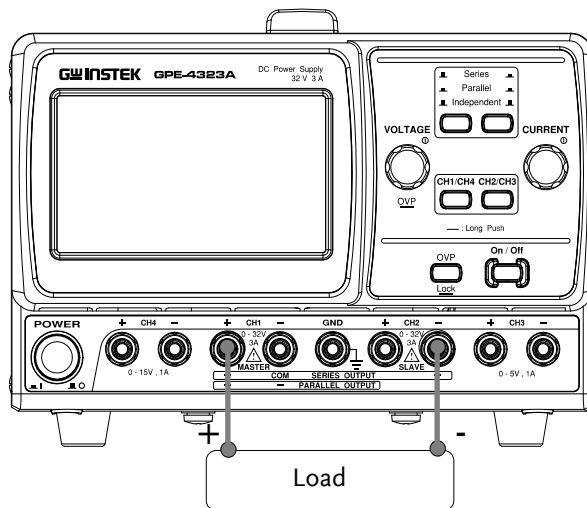

Output rating 0 V to 64 V / 0 A to 3 A

1. Press the Series/Parallel key to activate the series tracking mode. The **SER** icon will be lit on the LCD display.

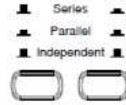

2. Connect the load to the front panel terminals, CH1+ & CH2- (Single supply).

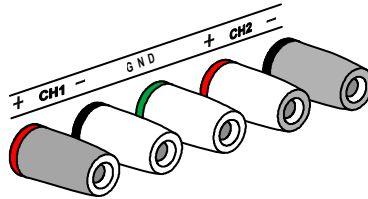

3. You can use the CH1/CH4 key to toggle to CH1 (① appears on the LCD display).



4. Use the voltage and current knob to set the CH1 output voltage and current level. (CH2 voltage is the same as CH1 value)

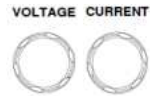

5. You can use the CH2/CH3 key to toggle to CH2 (② appears on the LCD display).



6. Use the current knob to set the CH2 output current level.



7. Press the Output key to turn on the output. The Output key will be lit.



Refer to the CH1 (Master) meter and indicators for the output level and CV/CC status.

Output voltage level Double the reading on the CH1 voltage meter.

Output current level CH1 meter reading shows the output current.

Series Tracking with Common Terminal

Connection

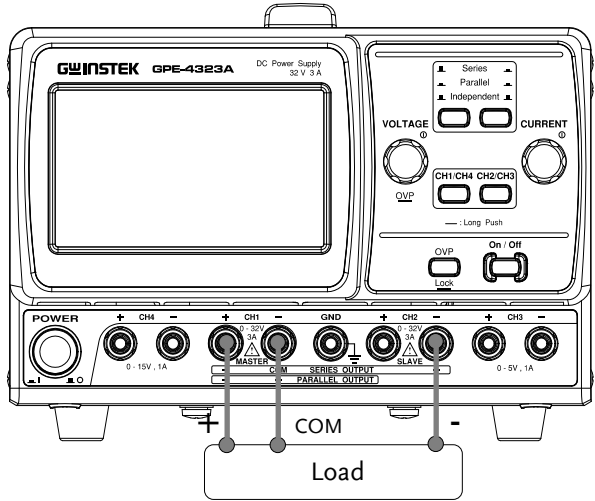

Output rating 0 V to 32 V / 0 A to 3 A for CH1 to COM
0 V to -32 V / 0 A to 3 A for CH2 to COM

1. Press the Series/Parallel key to activate the series tracking mode. The **SER** icon will be lit on the LCD display.

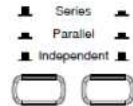

2. Connect the load to the front panel terminals, CH1+ & CH2-. Use the CH1 (-) terminal as the common line connection.

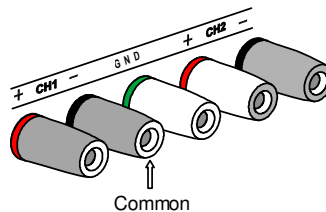

3. You can use the CH1/CH4 key to toggle to CH1 (1 appears on the LCD display).



4. Use the voltage and current knob to set the CH1 output voltage and current level. (CH2 voltage is the same as CH1 value)



5. You can use the CH2/CH3 key to toggle to CH2 (2 appears on the LCD display).



6. Use the current knob to set the CH2 output current level.



7. Press the Output key to turn on the output. The Output key will be lit.

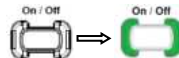

Refer to the CH1 (Master) meter and indicators for the output level and CV/CC status.

CH1 (Master) voltage level CH1 meter reading shows the output voltage.

CH1 (Master) current level CH1 meter reading shows the output current.

Refer to the CH1/CH2 meter and CH2 indicators for the output level and CV/CC status.

CH2 (Slave) voltage level The CH2 meter reading shows the output voltage.

CH2 (Slave) current level The CH2 meter reading shows the output current.

CH1/CH2 Parallel Tracking Mode

Background / Connection Parallel tracking operation allows the GPE-2323A/3323A/4323A to combine the output by internally connecting CH1 (Master) and CH2 (Slave) in parallel. CH1 (Master) controls the combined output voltage/current level.

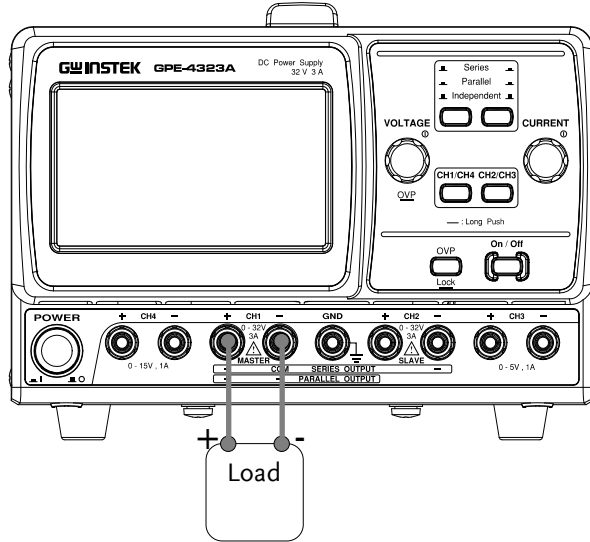

Output rating 0 V to 32 V / 0 A to 6 A

1. Press the Series/Parallel key to activate the parallel tracking mode. The **PARA** icon will be lit on the LCD display.

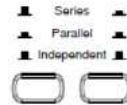

2. Connect the load to the CH1 +/- terminals.

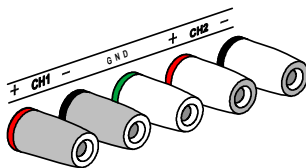

3. You can use the CH1/CH4 key to toggle to CH1 (1 appears on the LCD display).



4. Use the voltage and current knobs to set the output voltage and current. CH2 control function is disabled.

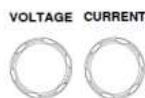

5. Press the Output key to turn on the output. The Output key will be lit.



Refer to the CH1 meter and indicator for the output level and CV/CC status. The operating mode of CH2 will appear as the **CC** icon on the LCD display.

- | | |
|----------------------|---|
| Output voltage level | The CH1 meter reading shows the output voltage. |
| Output current level | Double the amount of CH1 current meter reading. |

F AQ

Q1. I pressed the panel lock key but the output still turns on/off.

A1. For safety reasons the output key is not affected by the panel key lock feature.

Q2. The CH3 overload indicator turned on – is this an error?

A2. No, it simply means that the CH3 output current reached the maximum 5.2 A and the operation mode turned from CV (constant voltage) to CC (constant current). You can continue using the power supply, although reducing the output load is recommended.

Q3. The specifications do not match the real accuracies.

A3. Make sure that the power supply is powered on for at least 30 minutes, within +20 °C to +30 °C.

For more information, contact your local dealer or GW Instek at www.gwinstek.com / marketing@goodwill.com.tw.

APPENDIX

Fuse Replacement

Steps

1. Take off the power cord and remove the fuse socket using a minus driver.

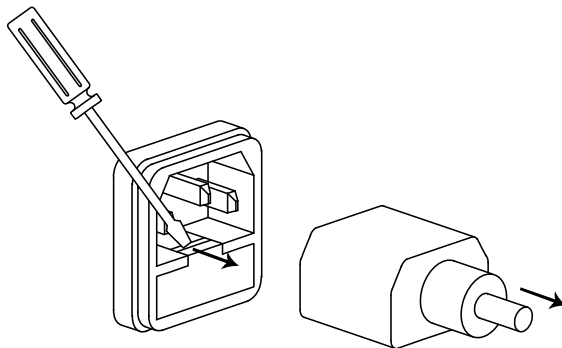

2. Replace the fuse in the holder.

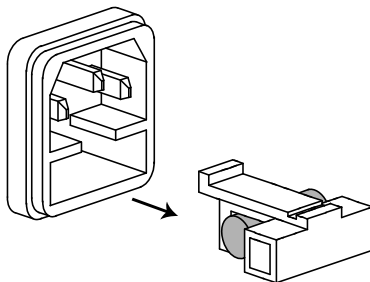

Rating

- 100 V / 120 V: T 6.3 A / 250 V
- 220 V / 230 V: T 3.15 A / 250 V

Specifications

The specifications apply when the GPE-1326A/2323A/3323A/4323A series are powered on for at least 30 minutes under +20 °C to +30 °C.

Output Ratings	CH1/CH2 Independent	0 V to 32 V / 0 A to 3 A 0 V to 32 V / 0 A to 6 A (GPE-1326A)
	CH1/CH2 Series	0 V to 64 V / 0 A to 3 A
	CH1/CH2 Parallel	0 V to 32 V / 0 A to 6 A
	CH3	5 V, 5 A (GPE-3323A) 0 V to 5 V, 1 A (GPE-4323A)
	CH4	0 V to 15 V, 1 A
	Voltage Regulation	Line
Load		$\leq 0.01\% + 3\text{ mV}$ (rating current $\leq 3\text{ A}$)
		$\leq 0.02\% + 5\text{ mV}$ (rating current $> 3\text{ A}$)
Ripple & Noise		$\leq 1\text{ mVrms}$ (5 Hz to 1 MHz)
Recovery Time		$\leq 100\text{ }\mu\text{s}$ (50 % load change, minimum load 0.5 A)
Temperature Coefficient		$\leq 300\text{ ppm/}^\circ\text{C}$
Current Regulation	Line	$\leq 0.2\% + 3\text{ mA}$
	Load	$\leq 0.2\% + 3\text{ mA}$
	Ripple & Noise	$\leq 3\text{ mArms}$
Tracking Operation	Tracking Error	$\leq 0.1\% + 10\text{ mV}$ of Master (No Load, with load add load regulation $\leq 100\text{ mV}$)
	Parallel Regulation	Line: $\leq 0.01\% + 3\text{ mV}$
		Load: $\leq 0.01\% + 3\text{ mV}$ (rating current $\leq 3\text{ A}$)
		Load: $\leq 0.02\% + 5\text{ mV}$ (rating current $> 3\text{ A}$)
	Ripple & Noise	$\leq 1\text{ mVrms}$ (5 Hz to 1 MHz)
	Series Regulation	Line: $\leq 0.01\% + 5\text{ mV}$ Load: $\leq 100\text{ mV}$
Ripple & Noise	$\leq 2\text{ mVrms}$ (5 Hz to 1 MHz)	
OVP	Range	CH1/CH2: OFF, ON (1 V to 36 V) CH3: OFF, ON (1 V to 6 V) (GPE-4323A) CH4: OFF, ON (1 V to 16 V) (GPE-4323A)
	Resolution	1 V
	Accuracy	$\leq \pm 1\text{ V}$

Display	LCD	4.3-inch single color LCD display
	Ammeter	CH1/CH2: 3.200 A full scale, 4 digits 或 3 digits
		CH3: 1.000 A full scale, 4 digits 或 3 digits CH4: 1.000 A full scale, 4 digits 或 3 digits
		6.200 A full scale, 4 digits 或 3digits (GPE-1326A)
	Current	1 mA or 10 mA
	Resolution	2 mA or 10 mA (GPE-1326A)
	Voltmeter	CH1/CH2: 32.00 V full scale,4 digits 或 3digits
		CH3: 5.00 V full scale,4 digits 或 3 digits
		CH4: 15.00 V full scale,4 digits 或 3 digits
	Voltage	10 mV or 100 mV
Resolution		
Accuracy	Setting/ Read back	Voltage: $\pm (0.1 \% \text{ of reading} + 30 \text{ mV})$ (4digits) $\pm (0.1 \% \text{ of reading} + 200 \text{ mV})$ (3digits)
		Accuracy
		Current: $\pm (0.3 \% \text{ of reading} + 6 \text{ mA})$ (4digits) $\pm (0.3 \% \text{ of reading} + 20 \text{ mA})$ (3digits)
		(1326A) $\pm (0.3 \% \text{ of reading} + 10 \text{ mA})$ (4digits) (1326A) $\pm (0.3 \% \text{ of reading} + 20\text{mA})$ (3digits)
CH3 on the GPE-3323A	Output	5 V \pm 5 %, 5 A
	Line	$\leq 3 \text{ mV}$
	Load	$\leq 5 \text{ mV}$
	Ripple & Noise	$\leq 1 \text{ mVrms}$ (5 Hz to 1 MHz)
	OVP	5.5 V
Insulation	Chassis and Terminal	20 M Ω or above (DC 500 V)
	Chassis and AC cord	30 M Ω or above (DC 500 V)
Operation	Indoor use, Altitude: $\leq 2000 \text{ m}$	
Environment	Ambient temperature: 0 °C to 40 °C	
	Relative humidity: $\leq 80 \%$	
	Installation category: II; Pollution degree: 2	
Storage	Ambient temperature: -10 °C to 70 °C	
Environment	Relative humidity: $\leq 70 \%$	
Power Source	AC 100 V / 120 V / 220 V $\pm 10 \%$, 230 V $\pm 10 \%$ / -6 %, 50/60Hz	
Consumption	550 VA / 420 W, MAX	

APPENDIX

Accessories	Test lead: Non-European GPE-1326A: GTL-104A x 1, GTL-105A x 1 GPE-2323A: GTL-104A x 2 GPE-3323A: GTL-104A x 3 GPE-4323A: GTL-104A x 2, GTL-105A x 2 Test lead: European GPE-1326A: GTL-204A x 1, GTL-203A x 1 GPE-2323A: GTL-204A x 2 GPE-3323A: GTL-204A x 3 GPE-4323A: GTL-204A x 2 , GTL-203A x 2
Dimensions	210 mm x 155 mm x 306 mm, (W x H x D)
Weight	Approx. 7 kg

Declaration of Conformity

We

GOOD WILL INSTRUMENT CO., LTD.

declare that the CE marking mentioned product satisfies all the technical relations application to the product within the scope of council:

Directive: EMC; LVD; WEEE; RoHS

The product is in conformity with the following standards or other normative documents:

© **EMC**

EN 61326-1 :	Electrical equipment for measurement, control and laboratory use — EMC requirements	
Conducted & Radiated Emission EN 55011 / EN 55032	Electrical Fast Transients EN 61000-4-4	
Current Harmonics EN 61000-3-2 / EN 61000-3-12	Surge Immunity EN 61000-4-5	
Voltage Fluctuations EN 61000-3-3 / EN 61000-3-11	Conducted Susceptibility EN 61000-4-6	
Electrostatic Discharge EN 61000-4-2	Power Frequency Magnetic Field EN 61000-4-8	
Radiated Immunity EN 61000-4-3	Voltage Dip/ Interruption EN 61000-4-11 / EN 61000-4-34	

© **Safety**

EN 61010-1:	Safety requirements for electrical equipment for measurement, control, and laboratory use - Part 1: General requirements
-------------	--

GOOD WILL INSTRUMENT CO., LTD.

No. 7-1, Jhongsing Road, Tucheng Dist., New Taipei City 236, Taiwan

Tel: +886-2-2268-0389 Fax: +866-2-2268-0639

Web: www.gwinstek.com Email: marketing@goodwill.com.tw

GOOD WILL INSTRUMENT (SUZHOU) CO., LTD.

No. 521, Zhujiang Road, Snd, Suzhou Jiangsu 215011, China

Tel: +86-512-6661-7177 Fax: +86-512-6661-7277

Web: www.instek.com.cn Email: marketing@instek.com.cn

APPENDIX

GOOD WILL INSTRUMENT EURO B.V.

De Run 5427A, 5504DG Veldhoven, The Netherlands

Tel: +31(0)40-2557790 Fax: +31(0)40-2541194

Email: sales@gw-instek.eu

I NDEX

Automatic out off	26	Ground symbol	5
Banana plug	25	load connection	
Caution symbol	5	independent mode.....	31
CC/CV	34	Load connection.....	25
CC/CV indicator	36	Operation mode	
Cleaning the instrument.....	7	Parallel Tracking	42
Common terminal, series		Series Tracking	37
tracking	37	Specifications	46
Cooling fan.....	22	Output current setting	
safety instruction.....	6	Manual	32
CV/CC		Output on/off	
CH1/CH2 indicator	32	FAQ	44
CH3 indicator.....	34	manual.....	26
CH4 indicator.....	36	Output voltage setting	
Operation theory	11, 23	Manual	32
Disposal instructions	8	Over load indicator	34
EN61010		Power supply	
Pollution degree	7	Safety instruction.....	6
Environment		Setup.....	24
Operation.....	7	Socket overview	22
Specification	47	Specification	47
Storage	7	Protective ground symbol	5
Front panel		remote output control	
Lock (manual).....	28	terminal overview.....	22
Overview	16	Service operation	
Fuse		About disassembly	6
Rating.....	45	Contact	44
Replacement.....	45	tracking mode	
Safety instruction.....	6	parallel.....	28, 29, 30
GPE series		Tracking mode	
Block diagram.....	13	Operation theory.....	10
List of features	12	Warning symbol	5
Operation theory	13	Wire, load.....	25
Technology overview	9		

