

## 5. Operation Steps

- 1) **Power supply:** Use the 12V standard adapter to power the probe.
- 2) **Zero Calibration:** Make sure the slider is in the "LOCK" position and press the zero button.
- 3) **Connect to the oscilloscope:** Connect the probe to the oscilloscope and make sure the grounding of the oscilloscope is normal.
- 4) **Select the range:** Select the appropriate range according to the range of the measured current.
- 5) **Connect to DUT:** Push the slider to the "OPEN" position, place the measured conductor into the wire grip, and then push the slider to the "LOCK" position. Make sure you hear a "click" sound indicating that it has been tightly clamped.
- 6) **Start the power supply of the DUT.**
- 7) **Set up the oscilloscope**

## 6. Warranty

- 1) Micsig warrants the main body of this differential probe for 1 year. During the warranty period, Micsig will be responsible for free maintenance for any failure caused by the quality of the product under normal use.
- 2) Under the following circumstances, Micsig will refuse to provide maintenance services or charge for a fee:
  - a. No packaging or anti-counterfeiting label.
  - b. Anti-counterfeit label has been altered or blurred beyond recognition.
  - c. Unauthorized disassembly, such as: changing wires, dismantling internal components, etc.
  - d. No sales voucher or the content of sales voucher does not match the product.

## 7. Safety Precautions

- 1) Non-professionals do not open the product casing
- 2) Do not use while case is open
- 3) Do not touch any bare metal while testing
- 4) Disconnect the power supply and circuit immediately when over range
- 5) Do not use in flammable and explosive environments

**Micsig** Shenzhen Micsig Technology Co., Ltd.

Tel: +86-755-88600880 Email: sales@micsig.com Web: www.micsig.com  
Add: A106, Huafeng Robot Industrial Park, Hangcheng Rd, Bao'an,  
Shenzhen, Guangdong, China, 518126

# Quick Guide

## High Frequency AC/DC Current Probe CP series

### 1. Overview

Micsig high frequency AC/DC current probe CP series has bandwidth up to 100MHz, accuracy up to 1%. With 5A/30A dual range design, degaussing and Auto-Zero completed in one press.

The wire grip able to measure 5mm diameter conductor. It has compact design, light weight, and a universal BNC interface allows it to work on all brands of oscilloscopes.



## 2. Characteristics

Model	CP503B	CP1003B
Bandwidth	50MHz	100MHz
Rise time	≤ 7ns	≤ 3.5ns
Range	5Arms (5A) 30Arms (30A)	
Max. Current Input	50Apk, 100Apk-pk, 30Arms	
Accuracy (Max continuous current @ DC and 45-66Hz)	±1% ±1mA (5A) ±1% ±10mA (30A)	
Lowest measurable current	1mA (5A) 10mA (30A)	
Noise	<4mApp (5A) <30mApp (30A)	
Delay	< 6.5ns (5A) < 8.5ns (30A)	
Output Sensitivity	1V/1A (5A, 1X) 1V/10A (30A, 10X)	
Overcurrent alarm value	≥ 5Apk (5A) ≥ 50Apk (30A)	
Power Supply	12V	
Max. Working Voltage	CAT I 300V	
Max. Floating Voltage	CAT I 300V	
Max. Conductor Diameter	5mm	
Temperature	Operating temperature: 0°C ~ 50 °C Storage temperature: -20 °C ~ 80 °C	

## 3. Appearance

### 1. Probe slider and wire grip

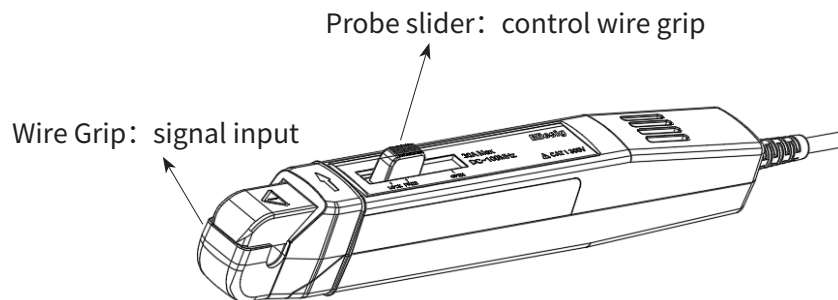

### 2. Control module

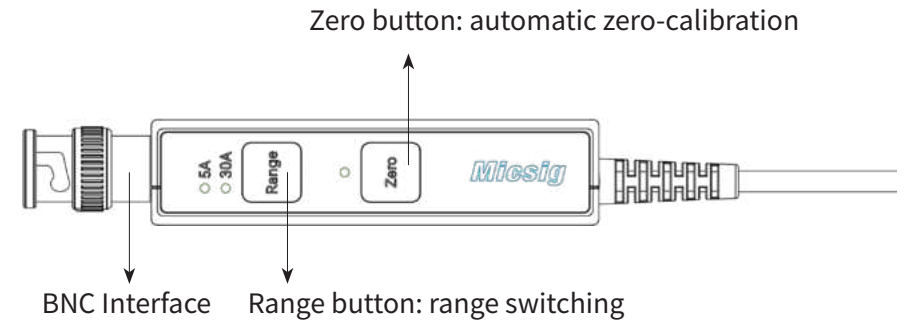

## 4. Precautions

### 1. The wire grip is a precision component, please pay attention:

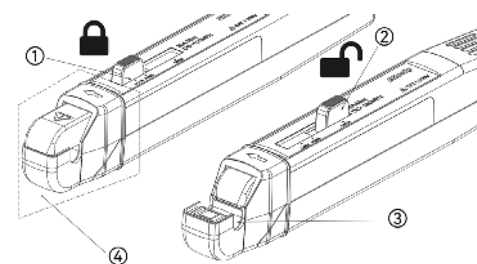

- ① When the slider is in the "LOCK" position, you can degauss the probe and take measurements.
- ② Move the slider to the "OPEN" unlocked position to insert or remove the wire from the wire clip.
- ③ The grip will accept wire diameters up to 5mm.
- ④ Place your finger behind the safe handling area (the area inside the dashed line in the figure) when measuring.

### 2. To ensure accurate measurements, degauss the probe under following conditions:

- \* Turn on the measuring system and allow a 20-minute warm-up time
- \* Before connecting the probe to the wire
- \* Whenever there is a current or thermal overload
- \* Whenever the probe is placed in a strong external magnetic field

3. Press the button "Zero □", the button lights up, probe will conduct degaussing and zero calibration. If the button light flashes 5 times, it means zero calibration failed.

4. When the current is overloaded, the status indicator light of the corresponding range button will flash.

5. For correct polarity readings, connect the probe from positive to negative so that the direction of current flow matches the arrow on the probe clip.

6. Must use the adapter provided with the probe for power supply, DO NOT use USB port on the oscilloscope.