

RRC2054

Rechargeable Smart Battery Pack Li-Ion 14.40V / 4s1p



Picture only for reference

Revision	Valid from	Revisions	Author
A	07Dec2012	First released version	Dietmar Fischer
B	07Aug2013	Second released version Add national approvals	Dietmar Fischer
C	13Jun2016	New issue date of national standards and Jeita-Diagram Improved cell to increase the continues discharge current: Increase from 4000mA to 4250mA Higher temperature resistance of plastic housing up to +90°C. Use of connector block instead of single contacts to improve the process reliability. Additional BIS mark, mandatory for battery sales in India. Additional CQC mark, based on GB31241 standard, mandatory for battery sales in China.	Dietmar Fischer
D	16Dec2016	Add chapter Cutoff-Voltage New approvals CQC & BIS, 30% SOC for shipping, packaging explanation. Updated mechanical drawing, charge and discharge start temperatures increased	Dietmar Fischer
E	14Jun2019	Next generation update: Cell Voltage, Charge Current, Discharge Current, Storage Temperature, Parameter Updates, Add chapter Life end control	Jörg Christmann
F	29Aug2019	Minor corrections, Added Life End Control Corrected Life Expectancy Definition	Andreas Warmsbach
G	13Nov2020	Changed OTD to +78°C Updated BIS certification to latest standard Changed wording: Life End Control → Battery Life Management Added information about UL94-V0 Packaging Specification: Outer-Box, Single-Box, Layer.	Andreas Warmsbach
G_correction	15Apr2021	Corrected altitude specification	Andreas Warmsbach
H	07Jun2021	Updated certifications: <ul style="list-style-type: none"> EAC removed (no longer mandatory) UKCA added (United Kingdom) CMIM added (Morocco) 	Till Etienne Wittig
H_Update1	28Jul2021	UR Mark updated in section 8.1	Michael Müller
I	23Mai2022	Multisourcing-Update: Added Samsung SDI type.	Andreas Warmsbach

1. Introduction	3
1.1. General Description	3
1.2. Manufacturer	3
1.3. Industry Standards	3
1.4. Acronyms and Terminology	3
2. Block Diagram	4
3. General Specification	5
4. Protection Description	7
4.1. Charge Protection	8
4.2. Discharge Protection	10
5. Functional Description	11
5.1. Operation Modes	11
5.2. Measurement Accuracy	12
5.3. Interface and Communication	12
5.4. Lifetime Data Log	15
5.5. Manufacturer Data	15
6. Mechanical	16
6.1. Mechanical Drawing	16
6.2. Pinout Description	17
6.3. Distortion	17
6.4. Connector	17
6.5. Housing Material	17
6.6. Ingress Protection	17
7. EMC and Safety Requirements	18
7.1. EMC	18
7.2. Safety	18
8. Regulatory Compliance / Certifications	18
8.1. Worldwide certifications and approvals	18
8.2. CE Requirements	18
9. Environmental Requirements	19
9.1. Climatic	19
9.2. Mechanical	19
10. Shipment	20
10.1. Charge Status	20
10.2. Packaging Specification	20
11. Safety Instructions	21
12. Annex	22
12.1. Variant-specific values	22
12.2. JEITA profile	23

1. Introduction

1.1. General Description

This specification describes the physical, mechanical, functional and electrical requirements for the smart rechargeable Lithium Ion battery pack from RRC power solutions, with article name RRC2054. The battery is comprised of four (4) Lithium Ion rechargeable 18650 cells, assembled in a 4 series / 1 parallel (4s1p) design. Each cell has an average voltage of 3.60V and a nominal capacity of $\geq 3.40\text{Ah}$, providing a battery pack of 14.40V and $\geq 3.40\text{Ah}$ nominal. The battery is designed to communicate with a host or a charger through the System Management Bus (SMBus) protocol. The battery is SMBus and Smart Battery Data Specification Revision 1.1 compliant. The battery design includes protection for over charge, over discharge and short circuit. Additional safety measures are designed into the battery to protect against over temperature and over current situations.

The battery pack consists of the individual elements noted below.

- 18650 cells
- Mechanical components
- Smart battery electronics
- Protection circuitry and components
- Plastic housing and packaging

1.2. Manufacturer

RRC power solutions GmbH
Technologiepark 1
66424 Homburg/Saar
Germany

1.3. Industry Standards

[SMBS] - System Management Bus Specification (Revision 1.1, December 11, 1998)

[SBDS] - Smart Battery Data Specification (Revision 1.1, December 11, 1998)

[SBCS] - Smart Battery Charger Specification (Revision 1.1, December 11, 1998)

[SBSS] - Smart Battery Selector Specification (Revision 1.1, December 11, 1998)

1.4. Acronyms and Terminology

The following acronyms and terms are commonly used throughout this document

CC/CV : Constant Current/Constant Voltage

FET: Field Effect Transistor

LED: Light Emitting Diode

TS: Temperature Sensor

SMBus: System Management Bus

JEITA: Japan Electronics and Information Technology Industries Association

FG: Fuel Gauge

2. Block Diagram

A block diagram is shown below, it is possible to identify the different components which are part of the smart battery.

Plastic housing

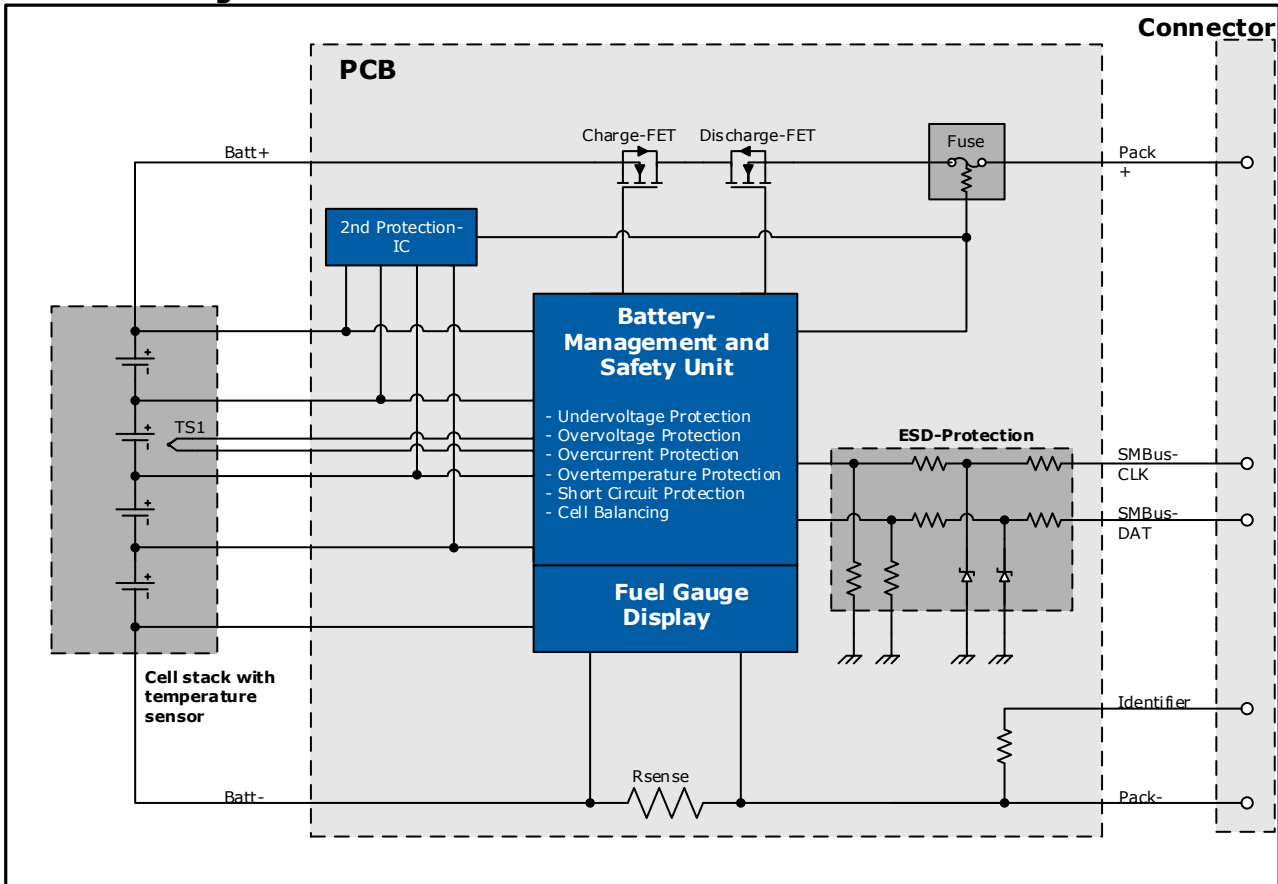

3. General Specification

The table below lists a general overview of the smart battery parameters.

Parameter	Value	Remark
Cell Type ¹	18650	-
Nominal Voltage	14.40V	-
Nominal Capacity/Energy ²	≥3.40Ah/48.96Wh	-
Minimum Capacity	3.30Ah	-
Maximum Charge Voltage	16.80V	Recommended charge voltage
Maximum Charge Current ^{(B)3}	≥2.00A	Recommended charge current: See (2) JEITA controlled charging
Charge time (with maximum charge current)	< 3h at 25°C	-
Charge Method ^(C)	Controlled Charging using an [SBCS] compliant charger	-
Charge timeout protection	18h	Counter reset with a discharge greater than 30mA
Continuous Discharge Current ^(A)	4.00A	-20°C to 0°C
	5.00A	0°C to 25°C
	4.50A	25°C to 35°C
	3.50A	35°C to 45°C
	1.30A	45°C to 60°C
Discharge Cut-off voltage	2.50V	Referred to individual cell voltage
Life Expectancy ^(D)	≥ 75% of initial capacity at 300 cycles	CC/CV Charge: 1.675A / 16.80V Discharge: 3.45A down to 10.00V @25°C
Shelf Life	12 months with 30% SOC >12 months with 40-60% SOC	Battery is set to shipping mode and stored at 25°C
Battery pack impedance	Max. 180mΩ initial	Measured at 1kHz AC 25°C fully charged battery
Weight	230g	-

(A) Continuous Discharge Current

This graph defines, depending on the ambient temperature, the maximum current which is possible to continuously discharge from the battery ("non-shadowed area"). Temporarily discharging the battery within the "shadowed area" is possible, however continuously doing so will cause the battery to generate heat that will eventually activate the over temperature protection.

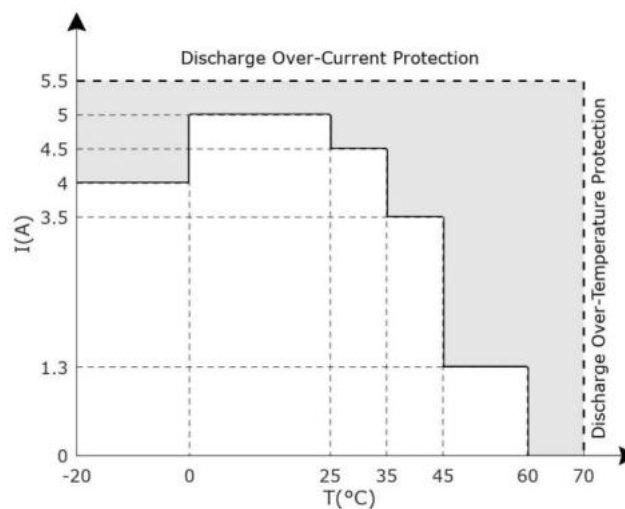

¹ See Annex – Cell Type/Manufacturer

² See Annex – Nominal Capacity/Energy

³ See Annex – Maximum Charge Current

(B) JEITA controlled charging

See Annex for a detailed view of the JEITA profile.

(C) Charge Method

Only a "Smart Battery Charger" (compliant to the [SBCS]) is suitable to charge this RRC smart battery.

The battery requests different charge voltages and charge currents over temperature and also over lifetime (see chapter 4.1.6). It is necessary that the charger is able to communicate with the battery and react to the battery requested charge parameters. All performance parameters given within this specification can only be guaranteed if the battery is charged with a [SBCS] level 2 or 3 compliant charger.

(D) Life Expectancy

The specified life expectancy corresponds to the minimum values of the cell specified and guaranteed by the cell manufacturer. RRC conducted its own tests with the battery pack which show a much higher life expectancy under the given conditions. Corresponding test data is available from RRC.

4. Protection Description

RRC smart batteries have an integrated protection circuit which ensure complete operational safety. This includes protection against over temperature, over charge/discharge or excessive current flow situations (e.g. over current, short circuits). The protection circuitry is composed of two levels of protection. The 1st level of protection which is composed of two FETs (Charge-FET and Discharge-FET) which interrupt current flow whenever one of the safety thresholds is reached. The 2nd level protection is a SCP type (Self Control Protector) fuse which will be triggered in case the 1st level protection fails to act. Once this protection is activated, the battery remains safe but is no longer functional. The slow conventional characteristic of the fuse breaks at a nominal current of 12A. The 2nd level protection is separate from the main electronic protection. The 1st level protection is classified into charge protection and discharge protection, which are specified in the next sub-chapters. To correctly interpret these protections, it is necessary to understand the following concepts presented in the image below:

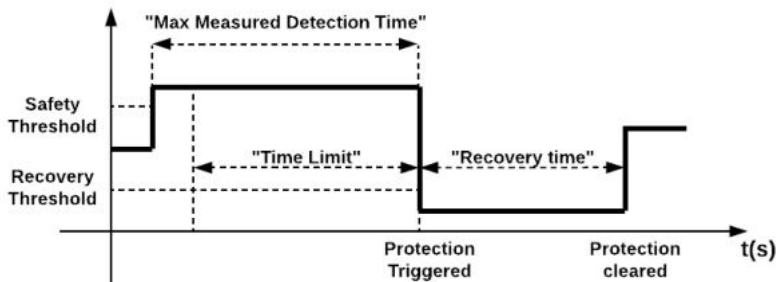

As an example, the battery discharge current is shown in the image above. When the current rises above the "Safety Threshold", the 1st level protection will be triggered after a delay of "Time Limit". If the current drops below "Safety Threshold" before the end of "Time Limit" delay, the protection will not be activated. The protection will always be activated within "Maximum Measured Detection Time". Once the protection is triggered, the current has to drop below "Recovery Threshold" for a period higher or equal to "Recovery Time". Once these conditions are met, the 1st level protection is cleared and current may flow again. This concept is valid for the different protections specified in the next sub-chapters.

The protection against excessive current flow is composed of three protections: over current, over load and short circuit protection. The difference between these lay on the current threshold and on the activation time, as shown in the image below.

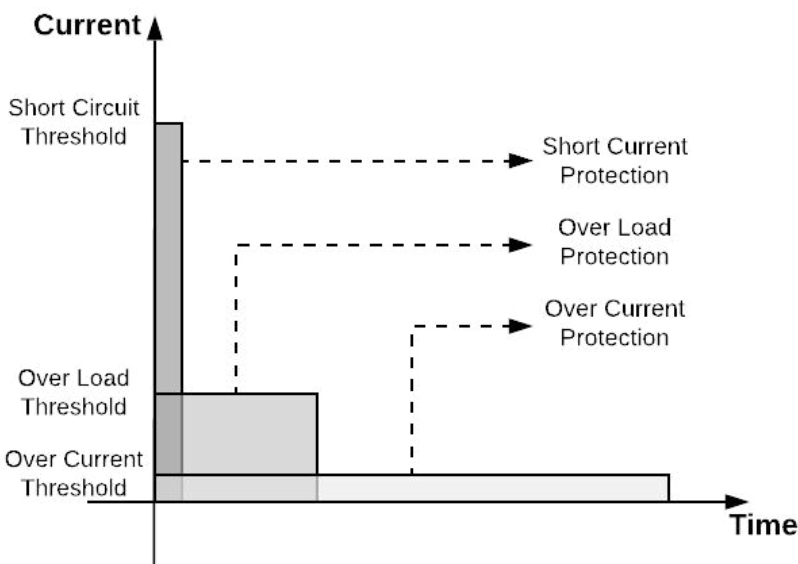

4.1. Charge Protection

RRC smart batteries supports JEITA guidelines which specify that charging voltage and charging current are optimized depending on the battery temperature. It manages more complex charging profiles by splitting the standard temperature range into sub-ranges which have adjusted charging voltage and charging current levels. The different 1st level protections which are designed to protect the smart battery during the charging process are defined in the next sub-chapters.

4.1.1. Cell Over Voltage (COV)

The COV protection keeps the battery safe against overcharging by monitoring the cells' voltage. If any cell exceeds the COV threshold, the 1st level protection will interrupt charge current flow. Following the JEITA guidelines, the COV thresholds also change depending on the battery temperature.

Temperature Range [°C]	COV Threshold [V]	COV Time Limit [s]	Max Measured Detection Time [s]	COV Recovery Threshold [V]
0 – 10	≥4.21 ⁽⁴⁾	2	< 4	4.00
>10	≥4.23 ⁽⁵⁾	2	< 4	4.05

The 2nd level protection circuit prevents the battery from charging if any cell voltage exceeds 4.350±0.025V. If exceeded, this protection circuit will be activated.

4.1.2. Over Current (OC)

The protection circuit provides continuous over current protection and prevents the battery from over charging currents.

OC Threshold [A]	OC Time Limit [s]	OC Recovery Threshold [mA]	Max Measured Detection time [s]	OC Recovery Time [s]
≥2.20 ⁽⁶⁾	2	200	< 4	5

4.1.3. Short Circuit (SC)

The protection circuit does not allow the battery to charge if a short circuit is placed across the battery terminal. If detected, the 1st level protection will be triggered and interrupt charge current flow.

SC Threshold [A]	SC Delay Time [µs]	Max Measured Detection Time [µs]	SC Recovery Time [s]
27.60	915	≤ 2000	30

4.1.4. Over Temperature (OT)

The protection circuit provides over temperature protection and prevents the battery from charging at high temperatures.

OT Threshold [°C]	OT Time Limit [s]	Max Measured Detection Time [s]	OT Recovery Threshold [°C]
58	2	≤ 4	50

If temperature is greater than 52°C and charging did not start, then charging is inhibited from starting.

⁴ COV Threshold 0°C – 10°C – see Annex

⁵ COV Threshold > 10°C – see Annex

⁶ Charge OC Threshold – see Annex

4.1.5. Charge Timeout (CTO)

The protection circuit provides charge timeout protection and prevents the battery from prolonged charging. The counter is incremented once every second when the Charge Current is greater than "Charge Threshold" current and is suspended when the charge current falls below "Suspend Threshold" current. The counter is reset when the battery goes into Discharge mode (discharge current > 20mA). When the counter equals Delay, charging will be interrupted.

CTO Charge Threshold [mA]	CTO Suspend Threshold [mA]	Delay [s]
50mA	20mA	64800

4.1.6. Battery life management

The battery life management prevents the battery from being overcharged when the battery is significantly aged. This protection feature is based on the "state of health" of the battery. The "state of health" (SOH) is the ratio of FullChargeCapacity() and DesignCapacity().

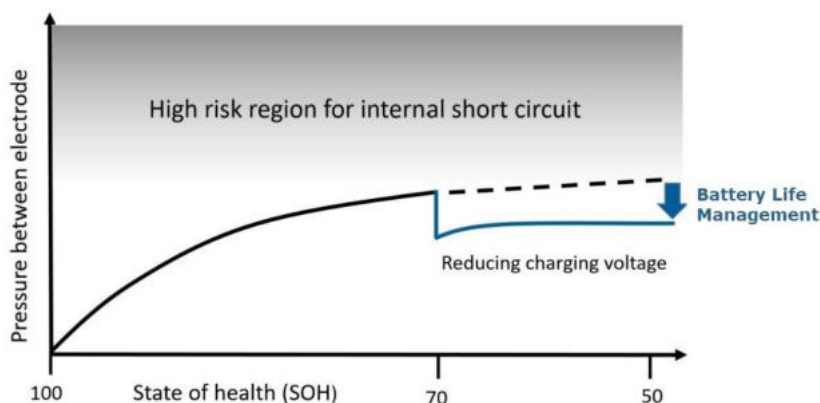

The requested ChargeVoltage() will be adjusted according to the SOH, allowing any smart charger to automatically react. Battery performance is not affected, as the lowered charge voltage at lower SOH matches to the actual required voltage to keep this SOH. Battery life management is a safety feature which reduces the risk of an age-related critical condition.

SOH Threshold	Requested ChargeVoltage
≥ 70%	16.80V
< 70%	16.60V

4.2. Discharge Protection

The different 1st level protections which are designed to protect the smart battery during the discharging process are defined in the next sub-chapters.

4.2.1. Over Current (OC)

The protection circuit provides continuous over current protection.

OC Threshold [A]	OC Time Limit [s]	OC Recovery Threshold [mA]	Max Measured Detection time [s]	OC Recovery Time [s]
5.50	2	200	< 4	5

4.2.2. Over Load (OL)

The protection circuit provides over load protection which has a higher current threshold and a faster reaction time in comparison with the OC protection.

OL Threshold [A]	OL Time Limit [ms]	Max Measured Detection time [ms]	OL Recovery Time [s]
11.10	23	< 35	30

4.2.3. Short Circuit (SC)

The protection circuit does not allow the battery to discharge if a short circuit is placed across the battery terminal. If detected, the 1st level protection will quickly interrupt current flow.

SC Threshold [A]	SC Delay Time [µs]	Max Measured Detection Time [µs]	SC Recovery Time [s]
27.60	916	≤ 2000	30

4.2.4. Cell Under Voltage (CUV)

The protection circuit prevents the battery from being over discharged. Once one of the cells drops under 2.50V, the 1st level protection will be activated therefore interrupting current flow.

CUV Threshold [V]	CUV Time Limit [s]	Max. Measured Detection Time [s]	CUV Recovery Threshold [V]
2.50	2	< 4	2.75

4.2.5. Over Temperature (OT)

The protection circuit provides over temperature protection and prevents the battery from discharging at higher temperatures. Discharging will be allowed once the battery temperature has dropped to acceptable levels.

OT Threshold [°C]	OT Time Limit [s]	Max Measured Detection Time [s]	OT Recovery Threshold [°C]
≥ 70 (7)	2	≤ 4	60

⁷ Discharge OT Threshold – see Annex

5. Functional Description

The battery has a Fuel Gauge (FG) electronic circuit which uses the Impedance Track™ Technology from TI to measure and calculate the available charge of the battery cells. No full charge / discharge learning cycle is required. The FG circuitry balances the output voltage of the different Li-ion cells using a cell balancing algorithm during charge. This ensures that all the cells within the battery pack are charged to the same voltage, therefore avoiding overcharge and excessive degradation of the cells. This balancing algorithm increases the usable battery pack capacity by preventing premature charge termination.

5.1. Operation Modes

To reduce power consumption, the FG has different operation modes as shown in the figure below. While the battery is charging or discharging the FG remains in normal mode. Depending on the different operational conditions, the FG will then jump between states as described below.

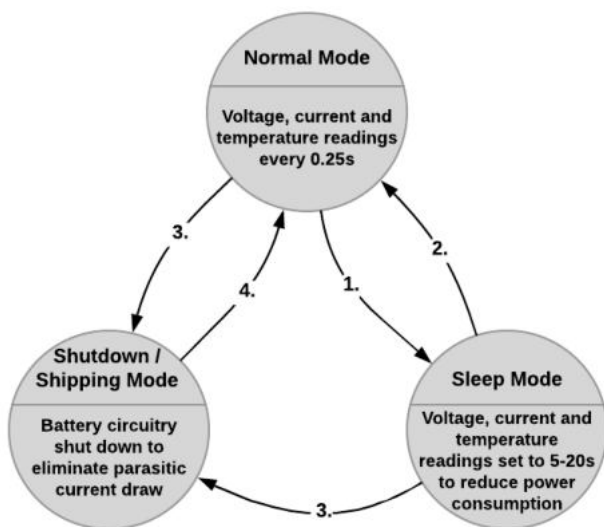

The different conditions and how they transition between states are defined below:

1. No charger or application detected for an interval greater than 5s and $|Current| < 10mA$
2. Charger or communication detected or $|Current| > 10mA$
3. Cell voltage less than 2.2V
OR
Shipping command (0x0010) sent twice over ManufacturerAccess() within 4 seconds (enter Ship Mode)
4. Charging voltage applied to the terminals of the battery

5.1.1. Normal mode

The system enters normal mode whenever charging or discharging process is taking place. Since the battery is directly operating the readings of voltage, current and temperature are updated every 0.25 seconds.

5.1.2. Sleep Mode

In sleep mode the battery is not being charged or discharged. The voltage, current and temperature acquisition frequency are reduced to decrease the energy consumption of the FG. In this mode both the Charge-FET and Discharge-FET are switched on.

5.1.3. Shutdown Mode

The system enters shutdown mode when the battery voltage falls below 8.8V (2.2V/cell). In this mode, the FG circuitry shuts down to reduce its energy consumption to a minimum and both the Charge-FET and Discharge-FET are switched off. This implies that the battery will not light up any LED indicators and will have 0V output voltage. To recover from this mode, the battery has to be inserted into a charger which is capable of detecting the "identifier" terminal (pin B of the battery). This pin indicates the charger should apply "wake-up" charge as described in the [SBCS]. Once woken-up, the battery will establish SMBus communication with the charger and transmit its desired charging voltage and charging current.

5.1.4. Shipping Mode

With the goal of reducing the self-discharge rate to a minimum, it is possible to send the battery into shipping mode. This mode is identical to shutdown mode with the difference that it is activated by the user. The instruction to set the battery into shipping mode are described in the diagram of chapter 5.1, note 3. It is not allowed to write to the battery in between each shipping mode command.

5.2. Measurement Accuracy

The battery registers which are available through SMBus communication have the following resolution and accuracy.

Measurement	Resolution	Absolute Accuracy
Voltage	1mV	±1%
Current	1mA	±2.5%
Temperature	0.1°C	From -20°C to 0°: ±3°C From 0°C to 80°C: ±1°C

5.3. Interface and Communication

The battery is designed to communicate with a host and/or a charger through the System Management Bus (SMBus) protocol. See chapter 1.3 for a list of adopted specifications.

5.3.1. LED Interface

The battery has a display to show the capacity information by using the push button. The LEDs show the relative state of charge (RSOC). Each LED segment represents 25 percent of the full charge capacity. The LED pattern definition is given in the table below. If the battery is in shipping mode or shutdown mode no LEDs will be displayed. The first blinking LED indication is dependent on the Remaining-Capacity-Alarm setting (default value: ≤10%).

Capacity	LED Indicators				Note
	1	2	3	4	
≤ 10%	X				Blinks
10% - 25%	X				Lit for 4 seconds
26% - 50%	X	X			Lit for 4 seconds
51% - 75%	X	X	X		Lit for 4 seconds
76% - 100%	X	X	X	X	Lit for 4 seconds

5.3.2. SMBus Logic Levels

The table below defines the ranges of the logic levels which are compliant with RRC smart batteries.

Symbol	Parameter	Limits	
		Minimum	Maximum
V _{il}	Data/Clock input low voltage	-0.30V	0.80V
V _{ih}	Data/Clock input high voltage	2.00V	6.00V
V _{ol}	Data/Clock output low voltage		0.40V

5.3.3. SMBus device address assignments

The slave addresses of the different bus participants are defined below. To send a write or a read command the 7-bit address must be shifted to the left and the last bit must be set to 0 or to 1, respectively.

Slave 7-bit Address	Description	Specification
0001 000	SMBus Host	[SMBS]
0001 001	Smart Battery Charger	[SBCS]
0001 010	Smart Battery Selector	[SBSS]
	Smart Battery System Manager	[SBSM]
0001 011	Smart Battery	[SBDS]

5.3.4. Read/Write SMBus Protocols

The smart battery communicates via a simple bi-directional serial data interface where each command is 1 byte long. The battery can operate either as a master and/or a slave device. By default, it will master the line to broadcast its desired charging voltage and charging current to the Smart Battery Charger address (0x12) every 10s to 60s (typically 50 seconds). It will additionally broadcast the AlarmWarning() (which is similar to the BatteryStatus() register) to the SMBus Host (0x10) and to the Smart Battery Charger (0x12) addresses. The AlarmWarning() will be broadcasted every 10 seconds while any terminate charge/discharge flag of BatteryStatus() is set. The user can also use his application host to query the battery registers. In case the broadcasts are not used, it is recommended to disable them. Please request the respective technical note from your distribution partner (TechnicalNote_BatteryMode_BatteryStatus_AlarmWarning).

The Smart Battery supports 3 different transfer protocols, **Write Word**, **Read Word** and **Read Block**. These protocols are described in the next sub-chapters, where the notation specified below is used. A "not shadowed" block indicates a message sent by the master and a "shadowed" block indicates a message sent by the slave.

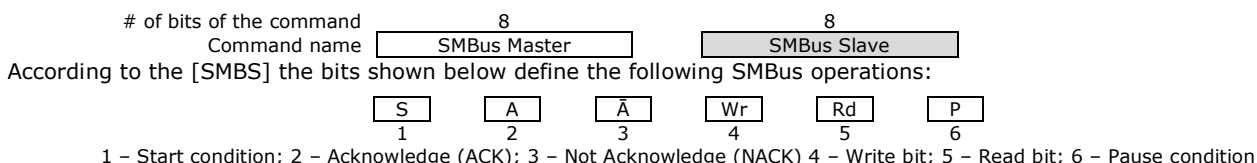

Write Word

After the Start Condition, the master writes the desired slave 7-bit address followed by the write bit, which is 0. The slave Acknowledges (ACK) and then the master sends the command code. The slave ACK again and the master sends the data word. The slave ACK each byte and the entire transaction is finished with a stop condition.

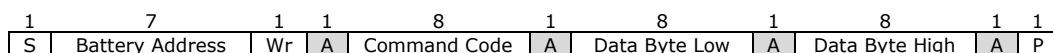

The battery broadcasts are sent to the battery charger address followed by Write Word commands.

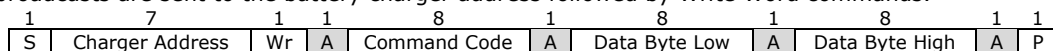

Read Word

After the Start Condition, the master writes the desired slave 7-bit address followed by the write bit, which is 0. The slave Acknowledges and then the master sends the command code. The slave ACK and the master send a repeated start condition followed by the battery address and the read bit. The slave ACK and then sends the two bytes of data. The master ACK each byte of data and finishes the transaction without a stop condition. The NACK indicates the end of the read transfer.

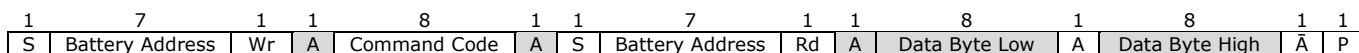

Read Block

A read block is similar to the Read Word protocol except that the first data byte received from the slave contains the number of bytes that will be returned and is capable of transferring up to 32 data bytes. The low byte data is transferred first.

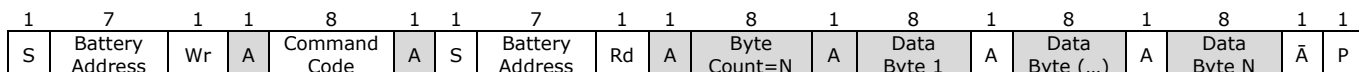

5.3.5. Smart Battery Registers

The registers which are available within the smart battery are listed in the table below. This table specifies the function name, the command code, a brief description, the unit of the register content, the requested SMBus protocol and the default value.

Function	Command Code	Description	Unit	SMBus Protocol
ManufacturerAccess()	0x00	Returns and sets data specific to the manufacture.		R/W word
RemainingCapacityAlarm()	0x01	Sets the threshold for the Remaining Capacity Alarm (RCA) flag from BatteryStatus() register.	mAh	R/W word
RemainingTimeAlarm()	0x02	Sets the threshold for Remaining Time Alarm (RTA) flag from BatteryStatus() register.	Minutes	R/W word
BatteryMode()	0x03	Sets the various battery operational modes.	Bit flags	R/W word
AtRate()	0x04	This function is the first half of a two-function call-set used to set the AtRate value used in calculations made by the AtRateTimeToFull(), AtRateTimeToEmpty(), and AtRateOK() functions. Positive values indicate charge and negative discharge.	mA	R/W word
AtRateTimeToFull()	0x05	Returns the predicted remaining time to fully charge the battery at the AtRate() value.	Minutes	Read word
AtRateTimeToEmpty()	0x06	Returns the predicted remaining operating time if the battery is discharged at the AtRate() value.	Minutes	Read word
AtRateOK()	0x07	Returns a Boolean value that indicates whether or not the battery can deliver the AtRate value of additional energy for 10 seconds. If the AtRate() value is zero or positive, the AtRateOK() function will ALWAYS return TRUE.	Boolean	Read word
Temperature()	0x08	Returns the pack's internal temperature.	0.1 K	Read word
Voltage()	0x09	Returns the battery's voltage (measured at the cell stack)	mV	Read word
Current()	0x0a	Returns the current being supplied (or accepted) through the battery's terminals.	mA	Read word
AverageCurrent()	0x0b	Returns the 1 minute average current.	mA	Read word
MaxError()	0x0c	Returns the expected margin of error.	Percent	Read word
RelativeStateOfCharge()	0x0d	Returns the predicted remaining battery capacity expressed as a percentage of FullChargeCapacity().	Percent	Read word
AbsoluteStateOfCharge()	0x0e	Returns the predicted remaining battery capacity expressed as a percentage of DesignCapacity().	Percent	Read word
RemainingCapacity()	0x0f	Returns the predicted remaining battery capacity.	mAh	Read word
FullChargeCapacity()	0x10	Returns the predicted battery capacity when fully charged.	mAh	Read word
RunTimeToEmpty()	0x11	Returns the predicted remaining battery runtime at the present rate of discharge.	Minutes	Read word
AverageTimeToEmpty()	0x12	Returns the predicted remaining battery runtime at the present 1 minute average rate of discharge.	Minutes	Read word
AverageTimeToFull()	0x13	Returns the predicted remaining battery time to full at the present 1 minute average rate of charge.	Minutes	Read word
ChargingCurrent()	0x14	Returns the battery's desired charging current.	mA	Read word
ChargingVoltage()	0x15	Returns the battery's desired charging voltage.	mV	Read word
BatteryStatus()	0x16	Returns the battery's status word.	Bit flags	Read word
CycleCount()	0x17	Returns the number of charge/discharge cycles the battery has experienced. A cycle is defined as 90% of DesignCapacity().	Cycles	Read word
DesignCapacity()	0x18	Returns the design capacity of the new battery.	mAh	Read word
DesignVoltage()	0x19	Returns the design voltage of a new battery.	mV	Read word
SpecificationInfo()	0x1a	Returns the version number of the SBDS the battery pack supports, as well as voltage and current scaling information.	Formatted word	Read word
ManufacturerDate()	0x1b	Returns the date the electronics were manufactured.	Formatted word	Read word
SerialNumber()	0x1c	Returns the battery serial number.	Number	Read word
Reserved	0x1d-0x1f			
ManufacturerName()	0x20	Returns a character array (ASCII representation) containing the manufacture's name.	String	Read block
DeviceName()	0x21	Returns a character array (ASCII representation) that contains the battery's name.	String	Read block
DeviceChemistry()	0x22	Returns a character array (ASCII representation) that contains the battery's chemistry.	String	Read block
ManufacturerData()	0x23	Returns data specific to the manufacture.		Read block

5.4. Lifetime Data Log

The FG circuitry contains a lifetime logging, where important data for warranty and analysis is stored. To access this information, please request the respective technical note from your distribution partner (TechnicalNote_ManufacturerAccess_Lifetime_Data).

5.5. Manufacturer Data

The FG IC provides additional registers which contain data over the operation of the smart battery, such as data of the activation of the different protections. To access this information, please request the respective technical note from your distribution partner (TechnicalNote_ManufacturerAccess_ManufacturerBlockAccess).

6. Mechanical

The mechanical specifications of the smart battery pack are defined in the following sub-chapters.

6.1. Mechanical Drawing

All values shown in mm.

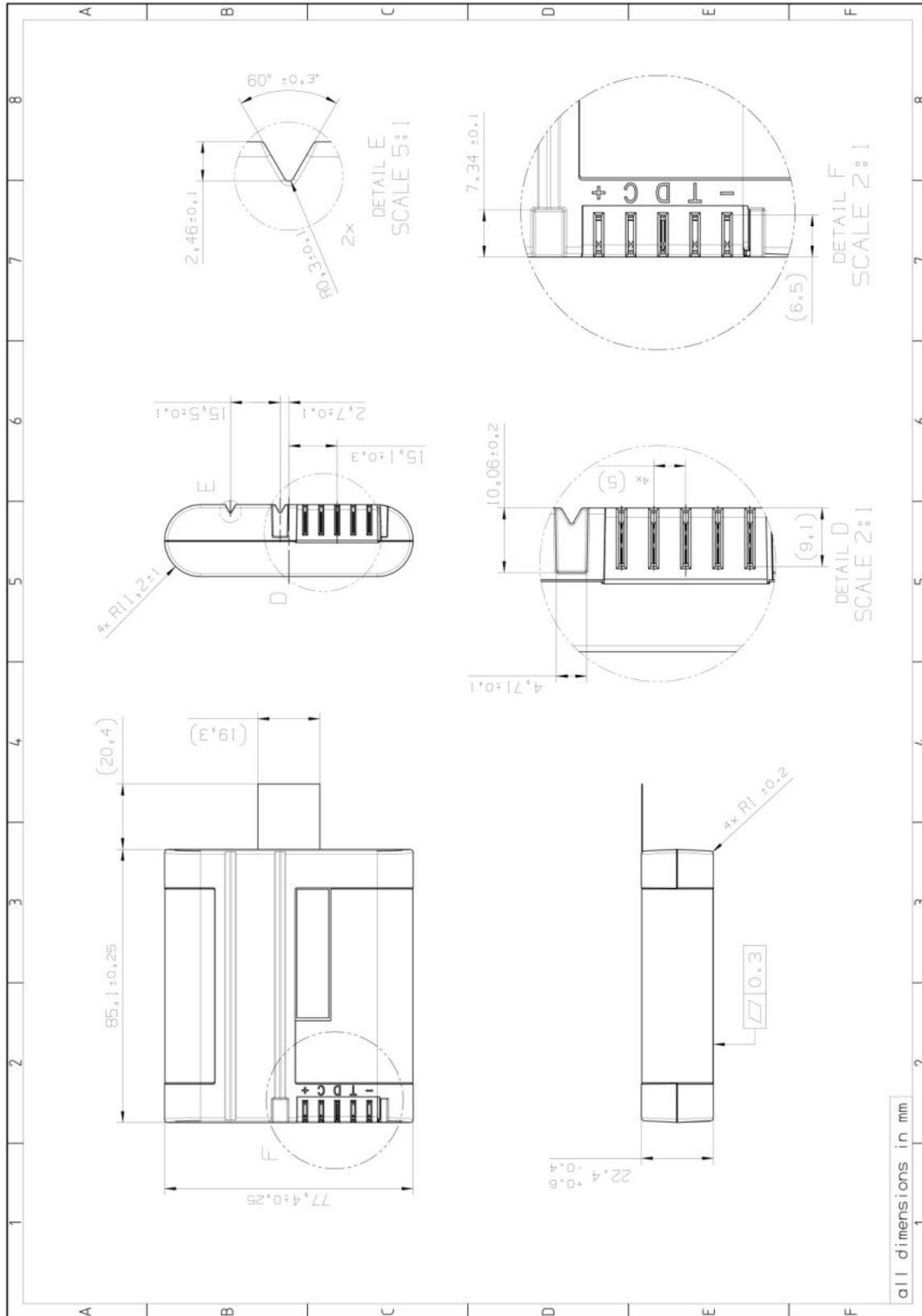

6.2. Pinout Description

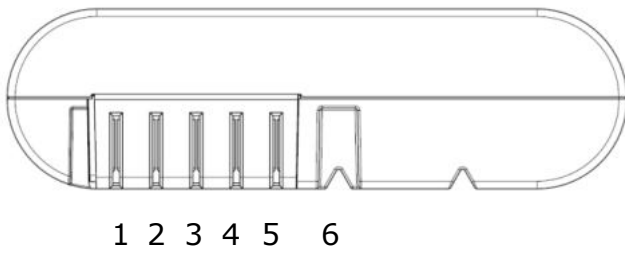

Pinout	Legend	Description
1	(-)	Negative battery pin.
2	(T)	Identifier. 300Ω ±5% fixed resistor, connected between (T) and (-).
3	(D)	SMBus Data. 1MΩ resistor is connected between (D) and (-).
4	(C)	SMBus Clock. 1MΩ resistor is connected between (C) and (-).
5	(+)	Positive battery pin.
6		Mechanical key feature.

6.3. Distortion

The maximum distortion of the pack is ≤ 0.3mm.

6.4. Connector

The connector has a current carrying capability of 10A (continuous).

6.4.1. Suggested Battery Mating Connectors

RRC Connector (up to 10A)

#210518 for board assembly 180°, MC20-180-10

#210519 for board assembly 90°, MC20-90-10

6.5. Housing Material

PC, PC/ABS ⁽⁸⁾

The enclosure flame retardant rating is UL94 V-0.

6.6. Ingress Protection

The enclosure ingress protection rating is IP40.

⁸ See Annex for Material)

7. EMC and Safety Requirements

7.1. EMC

The battery complies with

EN55032:2015

EN55024:2010

FCC Title 47 CFR, Part 15 Class B/ICES-003

7.2. Safety

The battery complies with

UL2054:2011

IEC62133-2:2017













The battery is tested in accordance with the UN ST-SG-AC10-11 Rev6 Amendment 1 Section 38.3 (ST/SG/AC.10/11/Rev.6)

- more commonly known as the UN T1-T8 transportation tests.

8. Regulatory Compliance / Certifications

8.1. Worldwide certifications and approvals

The battery complies with all applicable directives and appropriate standards (e.g. safety, EMC, environmental, recycling) for all of below stated countries.

Country:	Certificate:	Mark:	Country:	Certificate:	Mark:
International	CB	-/-	China	CQC	
Europa	CE		India	BIS	
United Kingdom	UKCA		South Korea	KC	
Russia	GOST-R		Taiwan	BSMI	
USA / Canada	UR		Japan	PSE	
Australia / New Zealand	RCM		Thailand	TISI	
Morocco	CMIM				

8.2. CE Requirements

The battery complies with EMC Directive 2014/30/EU.

All parts of the battery complies with RoHS Directive 2011/65/EU and 2015/863/EU, REACH Directive 1907/2006/EC and Battery Recycling Directive 2006/66/EC amended by 2013/56/EU.

9. Environmental Requirements

9.1. Climatic

9.1.1. Operating Temperature (ambient)

Charge: 0°C to 45°C

Discharge: -20°C to 60°C

9.1.2. Storage Temperature

Max: -20°C to 50°C

Recommended: -20°C to 25°C

Extended storage at temperature >40°C could degrade battery performance and life, see the following table for recommended storage conditions to maintain at least 80% recoverable capacity for a given storage duration and storage temperature.

Storage Duration	Storage Temperature
Up to 1 month	-20°C to 50°C
Up to 3 months	-20°C to 40°C
Up to 12 months	-20°C to 25°C

9.1.3. Altitude

Without restrictions the battery can be charged and discharged up to 5000m.

Without restrictions the battery can be stored up to 12000m.

9.1.4. Humidity

Recommended: 10 – 90%

Max: 96%, no dew condensation

9.2. Mechanical

9.2.1. Vibration

The battery complies with UN T3 Transportation test [USDOT-E7052] and IEC62133-2:2017 Chapter 7.3.8.1

9.2.2. Shock

The battery complies with UN T4 Transportation test [USDOT-E7052] and IEC62133-2:2017 Chapter 7.3.8.2

9.2.3. Drop



The battery complies with IEC62133-2:2017 Chapter 7.3.3

10. Shipment

10.1. Charge Status

The battery will be shipped in shipping mode with max. 30% state of charge.

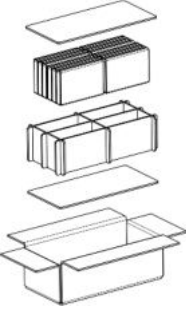
10.2. Packaging Specification

	Single-Box	Outer-Box	Pallet	
			Euro-Pallet 	
			One Layer	Max Layer
Dimension	112x81x30mm	385x245x151mm	Net ⁽¹⁾ :1126x776x151mm Gross ⁽²⁾ :1200x800x295mm	Net ⁽¹⁾ :1126x776x906mm Gross ⁽²⁾ :1200x800x1053mm
Quantity	1x Battery	24x Single-Box	3x2 + 3 Outer-Box	6 Layer
Battery-Weight	230g	5.52kg	49.68kg	298.1kg
Battery & Package-Weight	248g	6.85kg	Net ⁽¹⁾ : app. 61.65kg Gross ⁽²⁾ : app. 81.65kg	Net ⁽¹⁾ : app. 369.9kg Gross ⁽²⁾ : app. 389.9kg

⁽¹⁾Net: without pallet

⁽²⁾Gross: with pallet

11. Safety Instructions



Please read the following instructions carefully.

Please also check the battery manual available at <https://www.rrc-ps.com/manual2054>

- Do not subject the battery to mechanical shock, crush, impact, or puncture.
- Do not expose the battery to water, fire or excessive heat. Avoid storage in direct sunlight.
- Do not open or dismantle the battery.
- Do not short-circuit the battery.
- Do not store batteries haphazardly in a box or drawer where they may short-circuit each other or be short-circuited by other metal objects.
- Do not remove a battery from its original packaging until required for use.
- Charge the battery before initial use.
- Use an SMBus level 2 or 3 compliant charger only for charging the battery.
- Observe the plus (+) and minus (-) marks on battery and equipment and ensure correct use.
- Do not mix batteries of different manufacture, capacity, size, or type within a device.
- Keep the battery out of the reach of children.
- Keep the battery clean and dry.
- Use the battery only in the intended application.
- When possible, remove the battery from the equipment when not in use.
- Do not store a battery longer than 1 month in a discharged state.
- Do not store a battery longer than 1 year without recharge.
- The battery must be recycled or disposed of properly.
- If the battery should be leaking, do not allow the liquid to contact the skin or eyes. If you have been in contact, wash the affected area with copious amounts of water and seek medical advice.

If this battery is operated outside the parameters described in this specification, RRC disclaims any responsibility for the consequences thereof.

© RRC power solutions 2022.

All rights reserved.

No part of this document may be reproduced or transmitted in any form or by any means, electronic or mechanical, including photocopy, recording or any information storage and retrieval system, without prior written permission from RRC power solutions.

Germany/Headquarters

RRC power solutions GmbH
Technologiepark 1
66424 Homburg / Saar

Tel.: +49 6841 98090
Fax: +49 6841 9809280
Email: sales@rrc-ps.de
Web: www.rrc-ps.com

USA

RRC power solutions Inc.
18340 Yorba Linda Blvd.,
107-437
Yorba Linda, CA 92886

Tel.: +1 714 777 3604
Fax: +1 714 777 3658
Email: usa@rrc-ps.com
Web: www.rrc-ps.com

Hong Kong

RRC power solutions Ltd.
S-V,6/F, Valiant Industrial
Centre 2-12 Au Pui Wan Street
Fo Tan, N.T., Hong Kong

Tel.: +852 2376 0106
Fax: +852 2375 0107
Email: hkrcc@rrc-ps.cn
Web: www.rrc-ps.cn

China

RRC power solutions Ltd.
Room 1306, C Building,
Tianan International building,
Renmin South Road, Luohu
District, Shenzhen 518021

Tel.: +86 755 8374 1908
Fax: +86 755 8374 1861
Email: hkrcc@rrc-ps.cn
Web: www.rrc-ps.cn

12. Annex

12.1. Variant-specific values

Chapter	Parameter	Type "Panasonic"	Type "Samsung SDI"
3 General Specification	Revision Index	12	02
	Cell Type	NCR18650GA	INR18650-35E
	Cell Manufacturer	Panasonic	Samsung SDI
	Nominal Capacity/Energy	3.45Ah/49.68Wh	3.40Ah/48.96Wh
	Maximum Charge Current	2.415A	2.00A
4.1 Charge Protection	COV Threshold 0 – 10°C	4.21V	4.25V
	COV Threshold >10°C	4.23V	4.25V
	Charge OC Threshold	3.35A	2.20A
	Discharge OT Threshold	78°C	70°C
5 Mechanical	Material	PC/ABS	PC

12.2. JEITA profile

The JEITA profile defines, depending on the battery internal temperature, the charging current that the battery will request to the charger (ChargingCurrent()-command). The "non-shadowed area" shows the derating of the charging current to ensure that internal heat generation will not cause the battery to activate the over-temperature protection (OTC). Using a [SBCS] compliant charger following the JEITA profile is essential to ensure battery performance over lifetime. "Blue" lines indicate hysteresis.

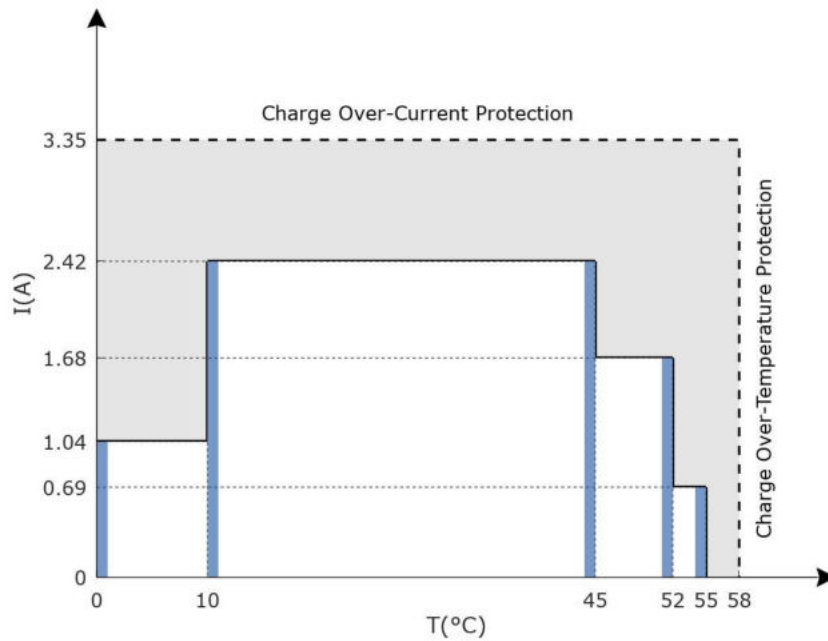

JEITA profile for Panasonic type

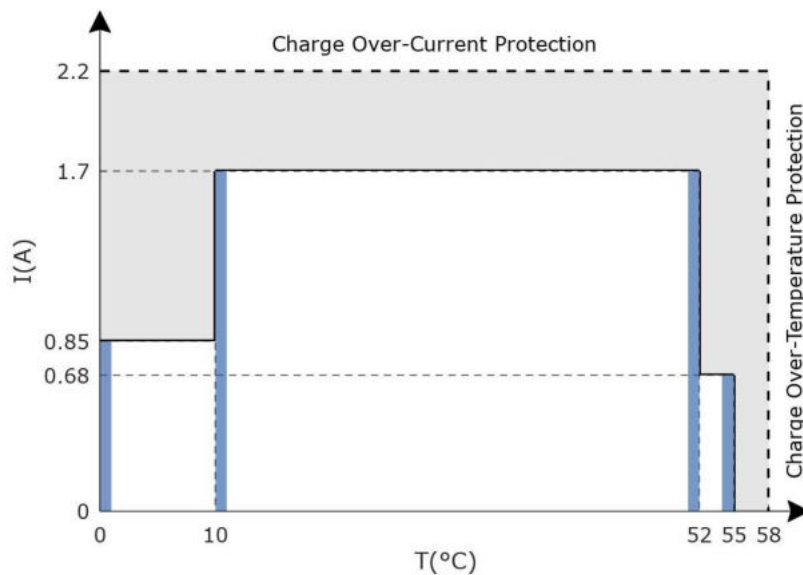

JEITA profile for Samsung type