

# 30A Current Shunt SCD30A



Datasheet

EN01A



SIGLENT TECHNOLOGIES CO.,LTD



# 30A Current Shunt SCD30A

## Main Function

### Basic Measurement Function

- DC Current Measurement : 30A
- AC Current Measurement : 30A
- Frequency Measurement Range:  
DC ~ 5kHz

## Product Overview

SCD30A digital multimeter current shunt, with outstanding measurement accuracy, is a product designed for high accuracy, high current, and user independent selection.

## Main Features

- Continuous sampling measurement for 30A high current
- Measurement accuracy below 0.3%

## Product Appearance



	<p><b>Caution:</b></p> <p>To avoid personal injury and other possible hazards, please ensure that the terminals are connected to cables reliably before connecting the shunt to DUT.</p> <p>Turn off the DUT before disconnecting.</p>
---	--

### Use safety tips

To better use the current measurement function of the current shunt SCD30A and avoid personal injury and other possible hazards, please carefully read the following instructions to use this product safely.

### Technical Parameter

			Accuracy ± (%Reading)
Function	Range	Frequency	1 Year TCAL <sup>°C±5°C</sup> [1][2]
DC Current	30A	-	0.3
AC Current		≤1kHz	0.3
		1kHz-5kHz	5

[1] Measuring ambient temperature TCAL is 23±5°C;

[2] When ambient temperature exceeds the TCAL range, an additional temperature errors (25ppm/°C) will occur.

### General Specifications

Mechanism	
Dimension	53mm × 40mm × 27mm
Other Characteristics	
Working Environment	Working Temperature: 0°C ~ 50°C; 40°C/80%RH (Non condensing)
	Storage Temperature : -20°C ~ 70°C
	Shock and Vibration : MIL-T-28800E , III , 5 level ( only for sine )
	Height above sea level : up to 3000 meters

**Operating Steps:**

**1. Connect the current shunt as follows:**

- (1) Inserting SCD30A during the SDM in shutdown state;

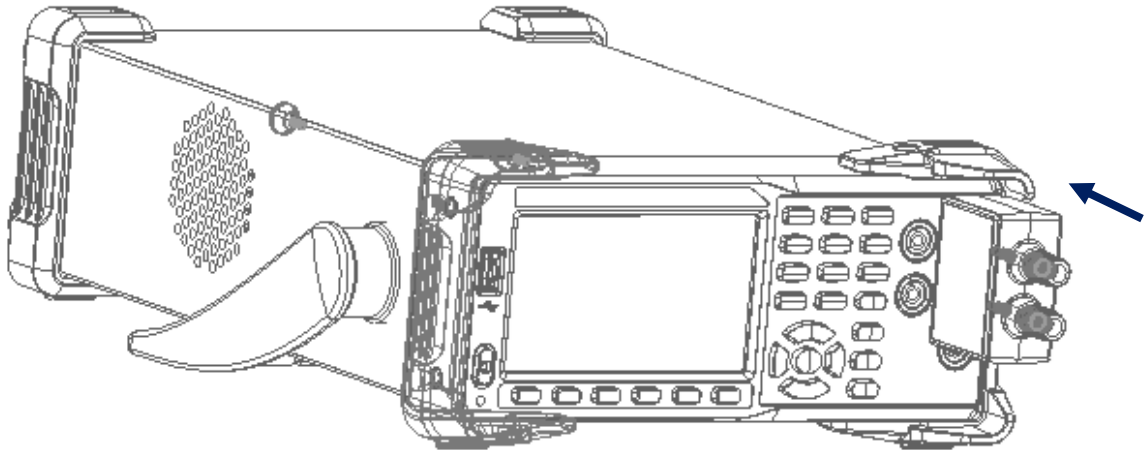

- (2) Connect the test connection cable firmly to the terminal post at the front end of the SCD30A and check to confirm that there is no safety risk;

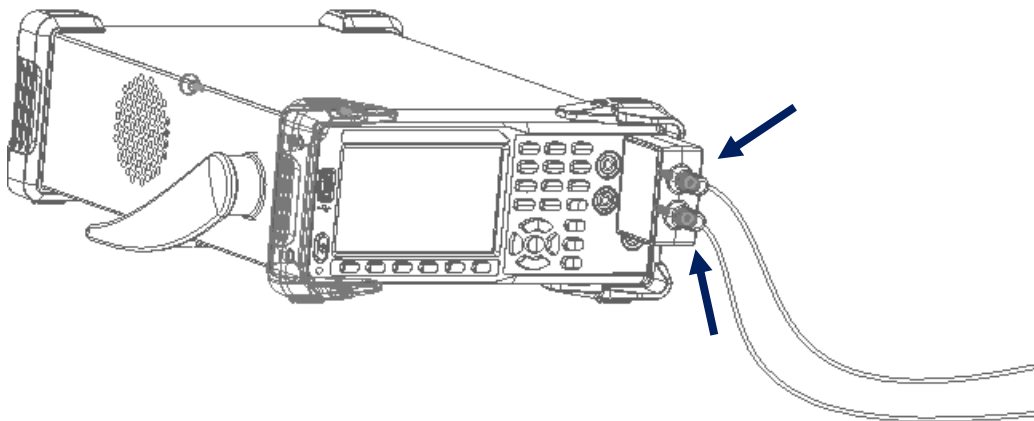

**Caution:**

To avoid personal injury and other possible hazards. When connected by inserting the terminal, the current shunt allows a maximum current of 15A to pass through; To measure 30A current, please use the terminal knob to securely and reliably connect the input cable.

- (3) Connect the other end of the test cable securely to the source under test.

**2. Set up the digital multimeter according to the following principles:**

- (1) Suggest only working with SIGLENT SDM series 5 ½ or 6 ½ multimeters. When the current to be measured is DC, please enter the DCI measurement function and select [Option Measure] ;

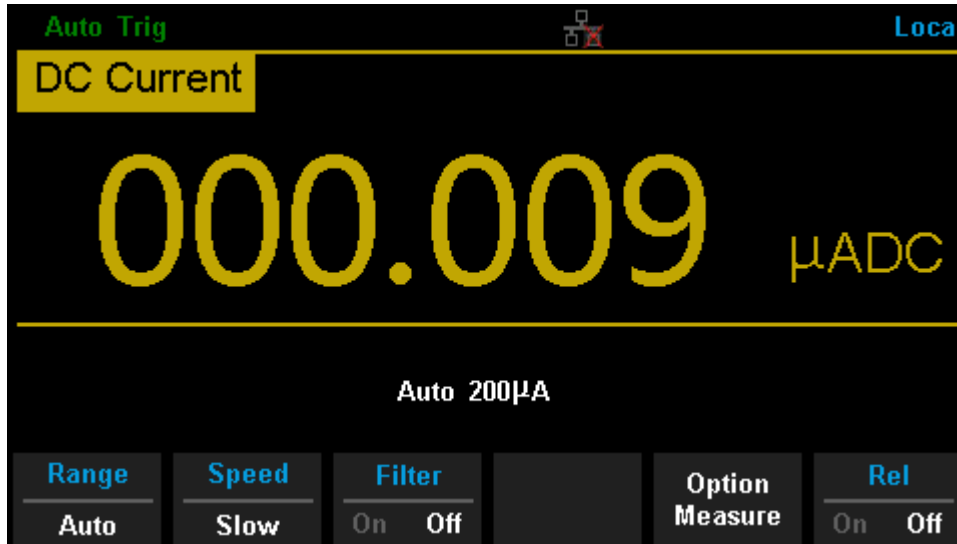

- (2) During the [Option] , select [SCD30A], and turn on the source under test;

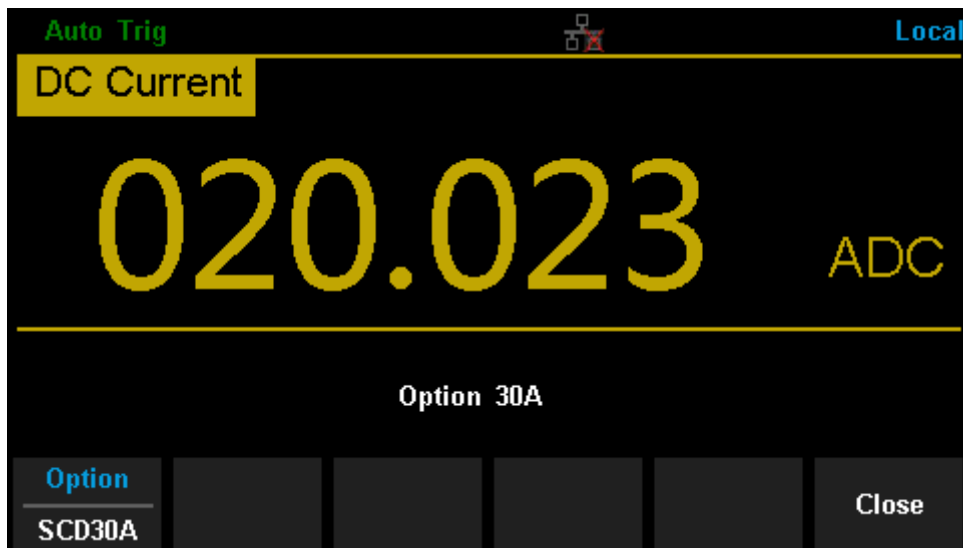

- (3) Select [Close] or enable other measurement ranges to exit the SCD30A measurement function;
- (4) Under the ACI measurement interface, following the same operating steps can achieve the measurement of AC high current;
- (5) After the measurement is completed, please turn off external input in a timely manner.



## About SIGLENT

SIGLENT is an international high-tech company, concentrating on R&D, sales, production and services of electronic test & measurement instruments.

SIGLENT first began developing digital oscilloscopes independently in 2002. After more than a decade of continuous development, SIGLENT has extended its product line to include digital oscilloscopes, isolated handheld oscilloscopes, function/arbitrary waveform generators, RF/MW signal generators, spectrum analyzers, vector network analyzers, digital multimeters, DC power supplies, electronic loads and other general purpose test instrumentation. Since its first oscilloscope was launched in 2005, SIGLENT has become the fastest growing manufacturer of digital oscilloscopes. We firmly believe that today SIGLENT is the best value in electronic test & measurement.

### Headquarters:

SIGLENT Technologies Co., Ltd  
Add: Bldg No.4 & No.5, Antongda Industrial  
Zone, 3rd Liuxian Road, Bao'an District,  
Shenzhen, 518101, China  
Tel: + 86 755 3688 7876  
Fax: + 86 755 3359 1582  
Email: [sales@siglent.com](mailto:sales@siglent.com)  
Website: [int.siglent.com](http://int.siglent.com)

### North America:

SIGLENT Technologies America, Inc  
6557 Cochran Rd Solon, Ohio 44139  
Tel: 440-398-5800  
Toll Free: 877-515-5551  
Fax: 440-399-1211  
Email: [info@siglentna.com](mailto:info@siglentna.com)  
Website: [www.siglentna.com](http://www.siglentna.com)

### Europe:

SIGLENT Technologies Germany GmbH  
Add: Staetzlinger Str. 70  
86165 Augsburg, Germany  
Tel: +49(0)-821-666 0 111 0  
Fax: +49(0)-821-666 0 111 22  
Email: [info-eu@siglent.com](mailto:info-eu@siglent.com)  
Website: [www.siglenteu.com](http://www.siglenteu.com)

Follow us on  
Facebook: [SiglentTech](https://www.facebook.com/SiglentTech)

