



TBVNA-6000

0.1 Hz –6 GHz Vector Network Analyzer

Operating Manual

Rev. 1.1

Certification

TekBox certifies that this product met the published specifications at the time of shipment from the factory.

Warranty

This product is warranted against defects in material and workmanship for a period of 2 years from the date of delivery. During this warranty period, TekBox will, at its own option, either repair or replace products which prove to be defective. For warranty service or repair, this product must be returned to the TekBox factory or to the distributor, where the product was purchased.

TekBox warrants that its software and firmware designated by TekBox for use with the instrument will execute its programming instructions when properly installed on the PC. TekBox does not warrant that the operation of the instrument, or software, or firmware will be uninterrupted or error free. The foregoing warranty shall not apply to defects resulting from improper or inadequate maintenance by the Buyer, Buyer supplied software or interfacing, unauthorized modification or misuse, operation outside the environmental specifications for the product, or improper site preparation or maintenance.

No other warranty is expressed or implied. TekBox specifically disclaims the implied warranties of merchantability and fitness for a particular purpose. The remedies provided herein are the Buyer's sole and exclusive remedies. TekBox shall not be liable for any direct, indirect, special, incidental, or consequential damages, whether based on contract, tort, or any legal theory.

Compliance and Calibration

European Union

Standard

EN 61326-1:2013

EN 61326-2-1:2013

EN 61010-1:2010/A1:2019/AC:2019-04

EN 61010-2-081:2020

EN 63000:2018

Title

Electrical equipment for measurement, control and laboratory use

– EMC requirements, Part 1: General requirements

Electrical equipment for measurement, control and laboratory use

– EMC requirements, Part 2-1: Particular requirements

Safety requirements for electrical equipment for measurement, control and laboratory use, Part 1: General requirements

Safety requirements for electrical equipment for measurement, control and laboratory use, Part 2-081: Particular requirements for automatic and semi-automatic laboratory equipment for analysis and other purposes

Technical documentation for the assessment of electrical and electronic products with respect to the restriction of hazardous substances

Additional, country specific conformity declarations are available through our distributors.

Recommended calibration period: 1 year, if the instrument is used permanently in an industrial environment; 2 years if it is used occasionally in a laboratory environment.

Safety

GENERAL SAFETY INSTRUCTIONS

Carefully read through the following chapters before powering and operating the TBVNA-6000. Observe all the precautions and warnings provided in this manual for all the phases of operation, service and repair of the Analyzer. The Analyzer must be used only by skilled and specialized staff or well-trained personnel with the necessary skills and knowledge of safety precautions. The Analyzer is an IEC-61010 CAT I device, there for no measurements shall be done involving a CAT II, III or IV environment. Operators must not remove the covers or parts of the housing. The Analyzer must not be repaired by the operator. Component replacement or internal adjustment shall only be performed by qualified maintenance personnel only.

Operating Environment

The TBVNA-6000 is intended for indoor use and should be operated in a clean and dry environment.

- Operating temperature range: 0 °C to +40 °C
- Operating humidity range: max. 85% RH, 24 hrs.
- Operating altitude range: ≤ 3000 m
- Storage temperature range: -20 °C to +60 °C
- Storage humidity range: max 85% RH, 24 hrs.

Note: Avoid direct sunlight, radiators and other heat sources in the vicinity of the instrument. The instrument relies on forced air cooling with internal fans and ventilation openings. Avoid restricting the airflow at the fan and ventilation openings. Keep away liquids and inflammable gases.

AC MAINS SUPPLY VOLTAGE

The TBVNA-6000 contains a linear power supply and does not automatically adapt to line voltage. The instrument is pre-set to the local mains voltage at its expected destination. However, before first operation, ensure that the mains voltage indicated at the mains voltage selector switch at the rear panel of the instrument matches your local mains voltage.

- 100 V_{RMS} – 120 V_{RMS} (± 3%) 50/60 Hz (± 5%)
- 200 V_{RMS} – 240 V_{RMS} (± 3%) 50/60 Hz (± 5%)



Warning: Manual mains voltage selection is required

Ensure that the mains voltage selector switch is set correctly to avoid damaging the instrument.

POWER AND GROUND CONNECTIONS

The instrument is supplied together with a country specific AC power cord. The AC power cord contains a molded, three-terminal, country specific plug and a standard IEC320 (Type C13) connector for making line voltage and protective earth connection. The mating IEC320 (Type C13) AC socket earth terminal is connected directly to the metal chassis of the instrument. For adequate protection against electrical shock hazard, the power plug must be inserted into a mating AC mains outlet containing protective earth contact. Use only the power cord specified for this instrument and specified for the country of use. Use the instrument only in installations protected with a ground fault switch.

Do not use excessive force on connecting cables to any connector of the instrument. The power cord should be unplugged from the AC outlet, if the instrument is not to be used for an extended period of time.

	<p>Warning: Electrical Shock Hazard</p> <p>Any interruption of the protective earth conductor within or outside of the instrument or disconnection of the protective earth terminal creates a hazardous situation with the potential of lethal electrical shock.</p> <p>Intentional disruption is prohibited.</p>
--	--

	<p>Caution:</p> <p>The outer shells of the N-connectors at the front panel of the instrument are connected to the instrument's chassis and therefore to protective earth.</p>
---	--

CLEANING

Clean only the exterior of the instrument. Use a damp, soft cloth for cleaning. Do not use any chemicals or abrasive sponges. Under no circumstances allow moisture or liquid to penetrate the instrument. To avoid electrical shock, the power cord must be unplugged from the instrument before cleaning.

	<p>Warning: Electrical Shock Hazard</p> <p>Disconnect the power cord, before cleaning the instrument. Do not remove covers when cleaning the instrument. Ensure that no moisture entered the instrument, before re-connecting it to AC mains.</p>
---	--

ABNORMAL CONDITIONS

Do not operate the instrument, if there are any visible signs of damage, abnormal smell or sound. In case that you suspect that the instrument's protection has been impaired, disconnect the power cord and secure the instrument against any unintended operation.

Only operate the instrument for the purposes specified by the operator. Do not connect the instrument directly to human subjects or for medical monitoring.

ESD PROTECTION

Electrostatic discharge can damage the instrument when connected or disconnected from the Equipment Under Test. Static charge can build up on the body and damage the sensitive circuits of internal components of both the instrument and the EUT.

To avoid damage, operate the instrument in an ESD-safe environment or wear a grounding wrist strap connected to the desktop anti-static mat via daisy-chained 1 M Ω resistor.

RF-INPUT PROTECTION

RF-Inputs are sensitive and can be damaged by excessive power or voltage transients.

The maximum input rating of the instrument is +20 dBm at Port 1 & 2 and +/- 25V at Ports A & B. Note that the input rating decreases with decreased internal attenuation or increased internal gain settings accordingly.

Before connecting the RF-inputs of the instrument to a RF-Source or to an Equipment Under Test, make sure that the internal settings are set to achieve the maximum input rating and only thereafter gradually modify the instrument settings to achieve the required dynamic range. Any excessive input power or voltage will cause the instrument to issue an optical and acoustical input overflow warning.

If you connect the instrument to an unknown source or Equipment Under Test, protect the RF-input with an attenuator / high-pass filter / limiter such as Tekbox TBFL1. Make yourself familiar with the input protection products offered on the Tekbox website.



Warning: RF-Input overload

Be cautious when connecting any unknown source to the RF-input. Carefully study the related information of this manual to avoid damage of the RF frontend circuitry.

Contents

1	Introduction to the TBVNA-6000Vector NetworkAnalyzer	9
1.1	Introduction	9
1.2	Application Overview	10
1.2.1	Spectrum Analyzer Utility	10
1.2.2	Phase Noise Analyzer	11
1.2.3	Logarithmic Spectrum Analyzer	11
1.2.4	Oscilloscope	12
1.2.5	Signal Generator	12
1.2.6	RF mV-Meter	13
1.2.7	THD Analyzer	13
1.2.8	Power Sweep	14
1.3	System Requirements	14
1.4	Packaging List	14
1.5	Unpacking and Preparations for First Use.	15
1.6	Software Installation	17
1.7	First Power - On	17
1.8	Front Panel Elements	21
1.9	Theory of Operation	22
1.10	Starting the Software	24
1.11	Network Analyzer Operation	25
1.11.1	Stimulus.	25
1.11.2	Receiver Section	26
1.11.3	Measurement Section	28
1.11.4	De-Embed Section	29
1.11.5	Memory Section	30
1.11.6	Measurement Panel	30
1.11.7	Progress Bar and Utilities	30
1.11.8	Action Group	31
1.12	Network Analyzer Calibration	32
1.12.1	Calibration Type	32
1.12.2	Calibration Standards Tab	34
1.12.3	Calibration Parameter Tab	35
1.12.4	Calibration Measurement Tab	36
1.12.5	Calibration Calculate Tab	36

1.12.6	The Cal Clear/Edit Push Button in the main window.....	37
1.12.7	Bode calibration	38
1.13	Measurements and Diagrams	38
1.13.1	The Equation Editor	44
1.14	Diagram Operations	47
1.14.1	Move and glue the diagram to other windows.	48
1.14.2	Print, Copy and Save diagrams.	48
1.14.3	Diagram Properties.....	49
1.14.4	Quick Diagram Setup	53
1.14.5	Trace selection and Trace Context Menu	54
1.14.6	Legend	55
1.14.7	Labels.....	56
1.14.8	Pan.....	56
1.14.9	Zooming.....	57
1.14.10	Scaling.....	58
1.14.11	Markers	59
1.15	The Main Dialog Menu.....	66
1.15.1	File / Load / Save Calibration	66
1.15.2	File / Load / Save Setup	66
1.15.3	File / Save S-Parameter	66
1.15.4	File / Select Home Path	66
1.15.5	System / System Test.....	67
1.15.6	System / Unlock Calibration	67
1.15.7	System / Change password.	67
1.15.8	System / Service	68
1.15.9	Measurement / Edit Memory Slots	68
1.15.10	Measurement / De-Embedding (full)	69
1.15.11	Measurement / Show Limits	71
1.15.12	Limits definition in the trace edit dialog.....	71
1.16	Utilities	73
1.16.1	Spectrum Analyzer Utility	73
1.16.2	Oscilloscope Utility	81
	Triggering.....	83
	Measurements	86
	Protocol analyzer.....	87
	Signal generator	89
1.16.3	RF Meters Utility.....	90

1.16.4	Demodulator Utility.....	94
1.16.5	Signal Generator Utility.....	95
2	Appendix.....	96
2.1	Compensation File Format.....	96
2.2	Time domain measurements.....	97
Application:	Fault location.....	98
Application:	Impedance variation.....	98
Application:	Filter tuning.....	98
2.3	VNA component measurements.....	99
2.4	Loaded Q measurement.....	101
2.5	Calibration standards File Format.....	101
2.6	VNA gain measurement function.....	103
G_{vf}	Matched forward voltage gain.....	103
G_{vr}	Matched reverse voltage gain.....	103
G_{if}	Matched forward current gain.....	104
G_{ir}	Matched reverse current gain.....	104
k	Stability Factor.....	104
G_{ms}	Maximum stable gain.....	104
G_{max}	Maximum available gain.....	104
G_{vfo}	Forward voltage gain with no load.....	105
G_{ifs}	Forward current gain with output short circuited.....	105
G_{vfa}	Forward voltage gain with arbitrary load.....	105
G_{ifa}	Forward current gain with arbitrary load.....	106
G_{tp}	Forward transducer gain with arbitrary load.....	106
2.7	Nyquist Plots in Bode Mode.....	106
	The Bode analyzer is subject to an additional manual and application notes.....	106
3	Specifications.....	107
4	Ordering Information.....	110
5	History.....	110

1 Introduction to the TBVNA-6000 Vector Network Analyzer

1.1 Introduction

A vector network analyzer measures the magnitude and phase characteristics of electrical networks and components such as filters, amplifiers, attenuators or antennas. While the measurement is usually performed in a 50 Ohms environment, the resulting four pole parameters provide insight into the transfer function, input and output impedance and much more. The high power signal output and the two additional high impedance inputs allow gain and phase measurements from DC to 500 MHz in the bode-analyzer operation mode. While the main function of the TBVNA-6000 is the measurement of 1 or 2-port networks, additional utilities integrated into the instrument will ease the electronics design process:

Main Features:

- 0.1 Hz – 6 GHz Vector Network Analyzer
- 0.001 Hz – 500 MHz Bode Analyzer (requires Bode Hardware Option)
- Signal generator 0.1 Hz - 6 GHz with 0.1 Hz resolution
- Four channel 60 MHz digital oscilloscope with 125 MS/s and 14 bit resolution. (Two 50 Ω inputs, two 1 M Ω inputs)
- Two-Channel DC - 6 GHz spectrum analyzer, with an unambiguous frequency range of DC - 60 MHz and an active sideband suppression for spurious-free signal measurements up to 6 GHz (under certain conditions)and cross correlation option. (Input channels can be among all 4 input ports)
- Power sweep measurements
- Wideband Power/Voltage measurements
- THD analyzer
- Phase noise analyzer
- General noise and bode measurements
- Two 1 M Ω // 15 pF, 500 MHz, +/-20 V Inputs for gain-phase and DC measurements

1.2 Application Overview

After launching the TBVNA-6000 software, a primary window with a variety of utilities appears:

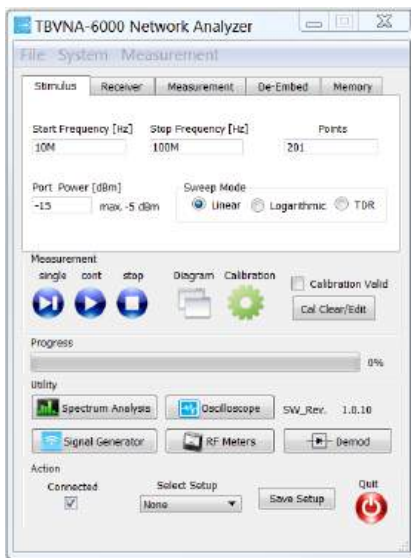

Figure 1-1 TBVNA-6000 software, primary window

The main window contains all control elements for the vector network analyzer operation, whilst the "Utility" group section has buttons that give access to other features, such as using the oscilloscope.

1.2.1 Spectrum Analyzer Utility

Spectrum Analyzer, DC to 6000 MHz, with an unambiguous frequency range of DC - 62.5 MHz and an extended frequency range of DC-6000 MHz with an "active" sideband suppression. This sideband suppression will try to delete spurious signals from the measurement and works for resolution bandwidth less than 200 kHz.

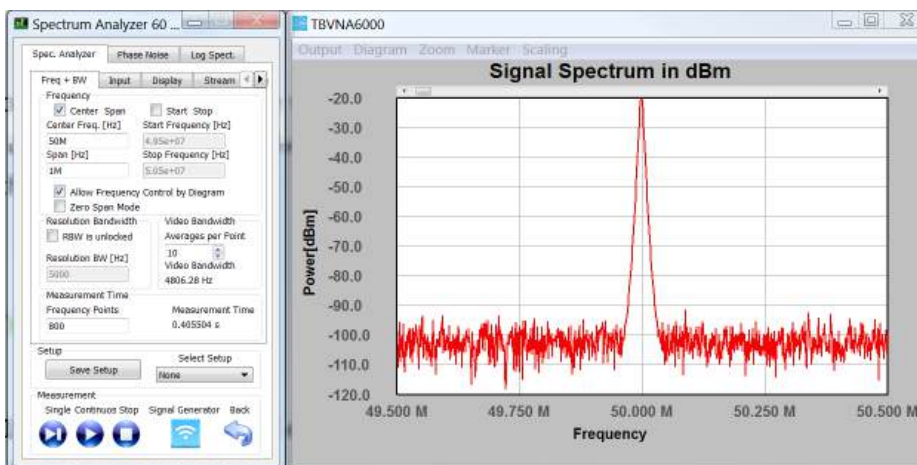

Figure 1-2 Measurement example



Note: The Spectrum Analyzer Utility has no physical sideband suppression like a preselector. Spurious signals can appear on broadband signals and higher resolution bandwidths. Spurious free measurements can only be done at frequencies below 62.5 MHz. However the "active" sideband suppression greatly improves the spurious suppression.

1.2.2 Phase Noise Analyzer

The phase noise analyzer tool, allows the measurement of the single sideband phase noise using the internal spectrum analyzer function. It will perform carrier search and measurement and performs all necessary calculations to display the carrier phase noise in a logarithmic diagram.

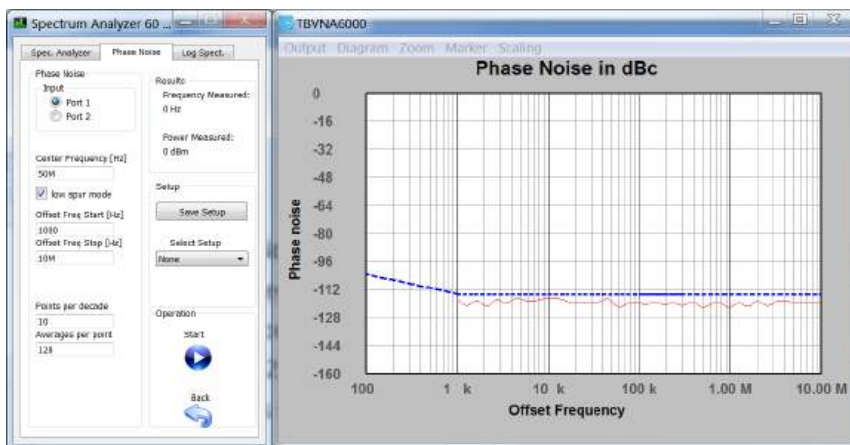

Figure 1-3 Measurement example

1.2.3 Logarithmic Spectrum Analyzer

A spectrum and noise analyzer DC - 62.5 MHz with a logarithmic frequency sweep and frequency dependent resolution bandwidth adjustment. When used as a noise analyzer, an LNA with at least 40 dB gain, such as the TBLNA-100, is recommended.

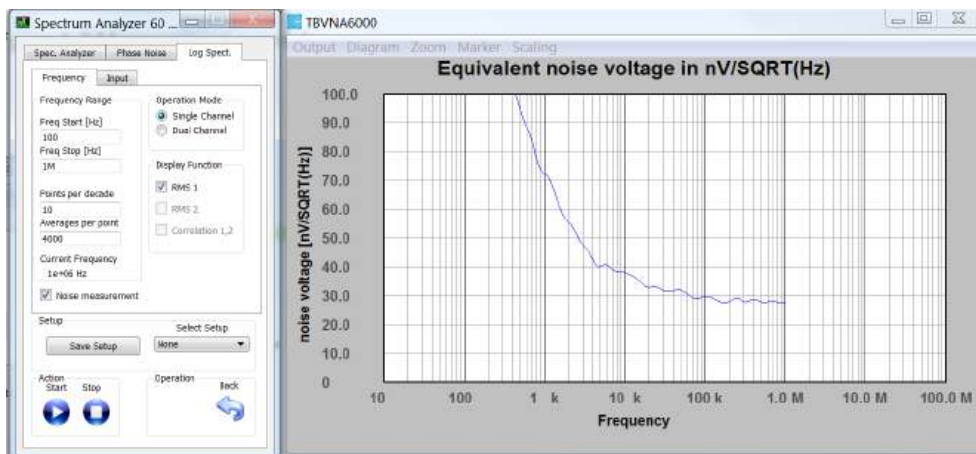

Figure 1-4 Measurement example

1.2.4 Oscilloscope

The oscilloscope displays signals in the time domain and can perform simple protocol decoding like I2C, SPI or RS-232 and has many built in measurement functions like RMS voltage, negative peak. The triggering also includes a pulse trigger mode, where the trigger can be set on certain pulse widths and levels. Note that the oscilloscope is DC-coupled. External DC-blocks for AC-coupling come with the VNA.

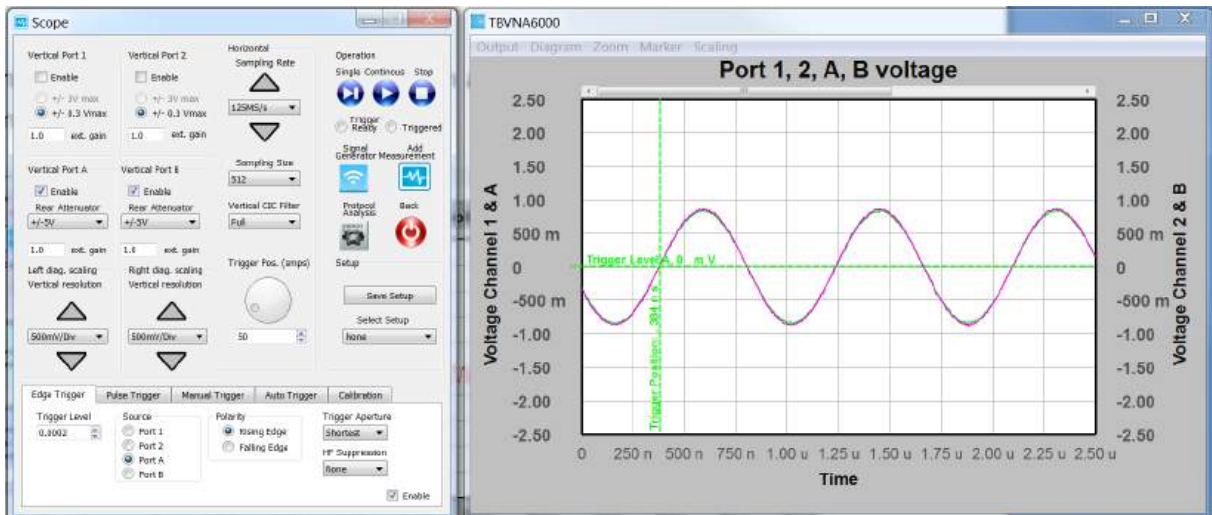

Figure 1-5 Measurement example

1.2.5 Signal Generator



Figure 1-6 Signal Generator

The signal generator allows to manually control the built in sinusoidal signal sources. Port 1 and Port 2 can output CW signals from 1 Hz to 6 GHz and up to -5 dBm. The BNC output port delivers +24 dBm up to 200 MHz and +10 dBm up to 500 MHz.

1.2.6 RF mV-Meter

The RF Millivolt Meter measures the RMS of a broadband signal with a -3dB bandwidth of about DC - 700 MHz.

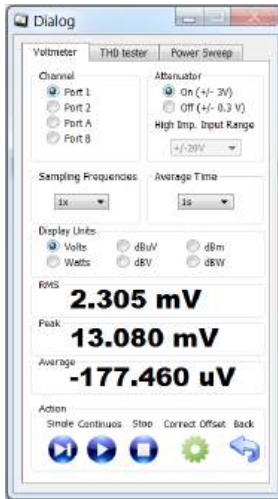

Figure 1-7 RF -mV Meter

1.2.7 THD Analyzer

The THD Analyzer allows the measurement of a CW signals harmonic content and will calculate SND and other THD parameters within the 6 GHz range.

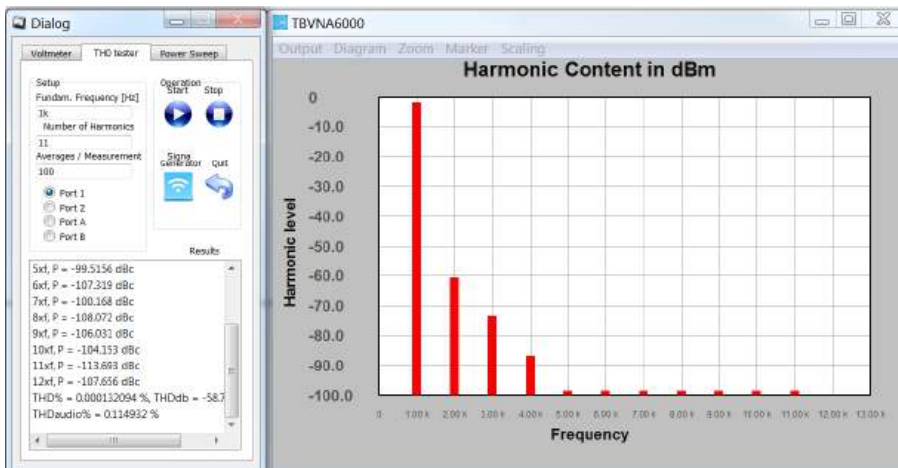

Figure 1-8 THD Analyzer

The above example shows the measurement of the internal signal source at 1 kHz.

1.2.8 Power Sweep

The power sweep function allows the measurement of the signal transfer curve over power at a certain frequency.

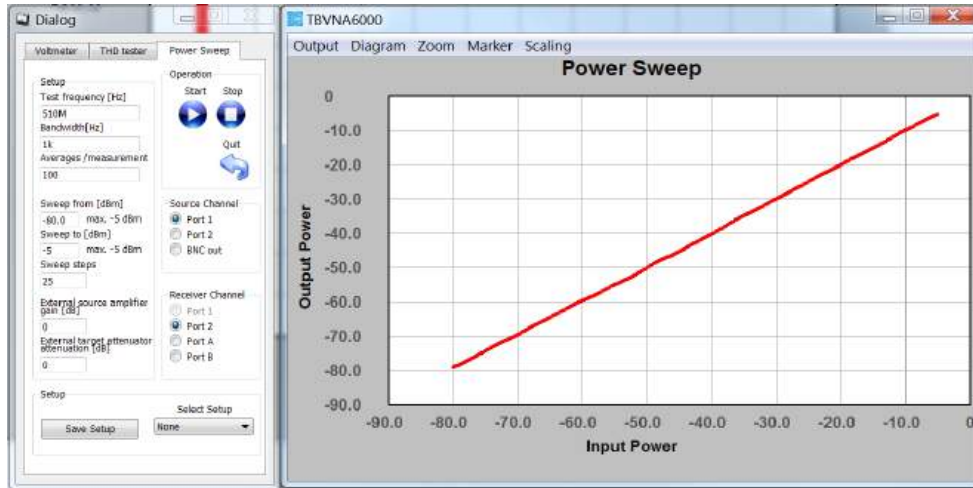

Figure 1-9 Power Sweep

1.3 System Requirements

The TBVNA-6000 system software requires a Microsoft Windows(R) 7 (SP1) 64 Bit, Windows 10 (R), Windows 11 (R) compatible computer with an USB 2.0 high speed interface, about 200 MB free disk space, an Intel Core i5 (R) processor with 3 GHz clock speed (or equivalent) and 4 GB of system memory as minimum recommendation. A high- resolution screen of better or equal than 1280x1024 pixels is required, 4k resolution is recommended for more detailed data display.

1.4 Packaging List

When opening the TBVNA box please check if following items are included in the package:

- TBVNA-6000 Vector Network Analyzer
- USB cable with type A and type B connector
- IEC power cord
- USB Stick containing the TBVNA-6000 software
- Quick Start Guide

1.5 Unpacking and Preparations for First Use.



Figure 1-10 TBVNA-6000 side view

Carefully unpack the shipping box and remove the packaging material. Carefully check your TBVNA-6000 for any shipping damage.

Check if the instrument's AC mains supply voltage matches the power grid voltage in your country. To do so, turn the analyzer around and have a look at the rear panel.

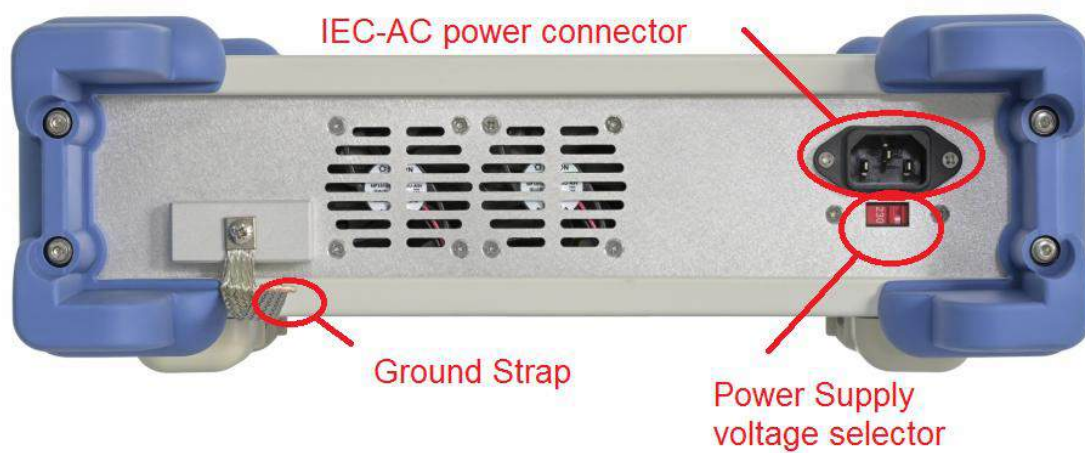

Figure 1-11 TBVNA-6000 rear view

Check the currently selected AC mains supply voltage on the power supply voltage selector.



Figure 1-12 TBVNA-6000 mains supply voltage selector

If the displayed voltage DOES NOT match your countries power grid voltage, please move the voltage selector switch in the opposite direction using a fitting tool, e.g. screw-driver.

Possible settings are: **115 VAC and 230 VAC.**

For voltages in the range 100 VAC to 120 VAC use the 115 VAC setting.

For voltages in the range 200 VAC to 240 VAC use the 230 VAC setting.

	<p>Warning: Mains voltage selector</p> <p>Operating the TBVNA-6000 Analyzer set to the wrong mains supply voltage may damage the equipment.</p>
--	--



Figure 1-13 IEC cable connector

Use your supplied IEC-power-chord and plug it into the TBMR power inlet on the back of the device. Plug the power cable then into a suitable power plug. Now connect the TBMR-USB port to your PC using the supplied USB cable.



Figure 1-14 supplied USB cable



Figure 1-15 TBVNA-6000 front view

1.6 Software Installation

Plug the supplied USB Stick into the USB port of the PC which you want to connect to the TBVNA-6000 and open the software folder. Start the "TBVNA-6000_Setup_Vxxx.exe" file as administrator. The Installer will guide you through the rest of the Installation.



Welcome to TBVNA-6000 VNA Setup

6 GHz Multifunctional Analyzer Software

Install

Options

Copyright © 2025 TekBox

Figure 1-16 TBVNA-6000 installer window

The Installer will install both the PC software as well as the device driver.

1.7 First Power - On

After the software has been successfully installed and the PC is linked to the TBVNA-6000, the device can be powered on. To do so, turn on the power switch shown in Figure 1.6 and wait until P1 and P2 Active LEDs shortly flash up.

If the USB driver is loaded correctly, the green LED "Connected" will light up on the analyzer front panel. The display can also be configured to display the measurement graphs.

In the device manager a new device folder "TekBox" should appear:

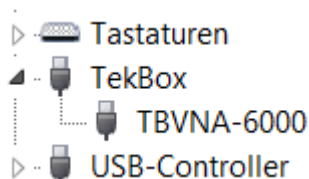

Figure 1-17 Windows Device Manager indicating that the VNA is successfully connected

If the analyzer does not connect successfully to your PC, please verify the USB connection. Turn off the analyzer and turn it back on after 2 seconds to check Windows Status outputs in the right lower corner of the screen.

If everything is correctly installed, you can now invoke the main application by double-clicking the Desktop icon or selecting the application from the program list.

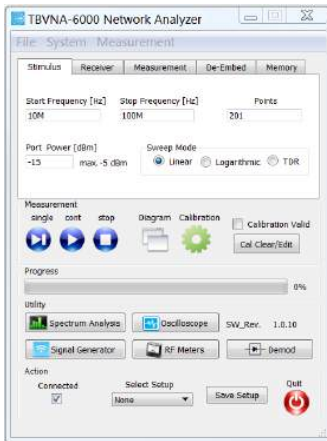

Figure 1-18 Main application window

If the device driver is properly loaded, the "Connected" - box is checked and the analyzer is ready for operation.

For a first test, click on the "single" measurement button:

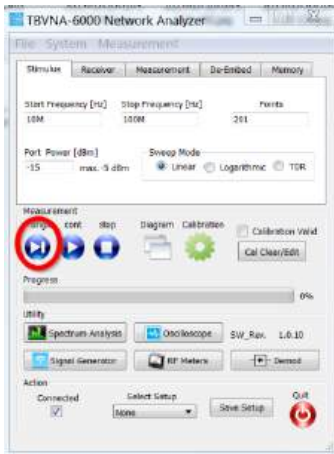

Figure 1-19 Main EMI analyzer window "Single Measurement" marked

Next, press the "Diagram" button

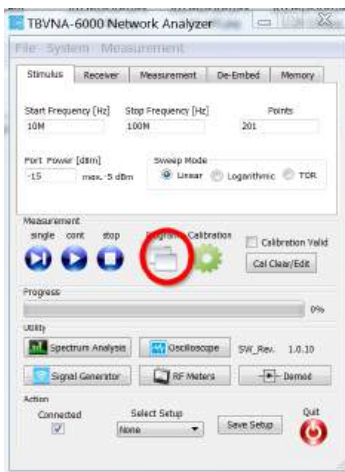

Figure 1-20 Main EMI analyzer window "Diagram" marked

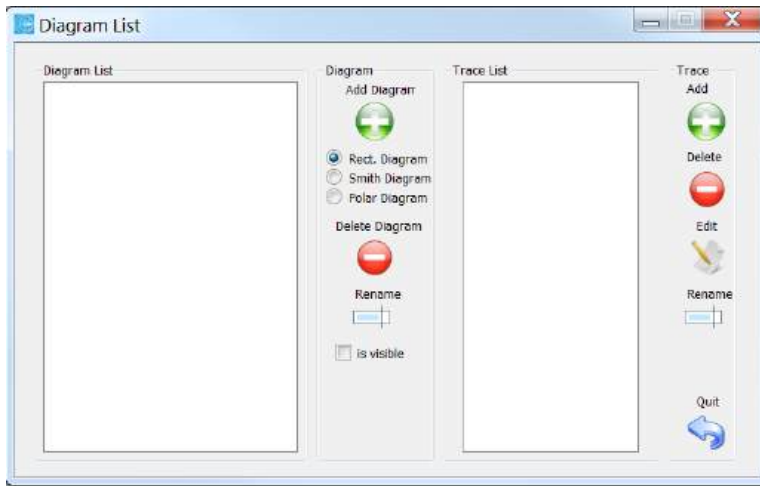

Figure 1-21 Diagram List window

Press "Add Diagram"

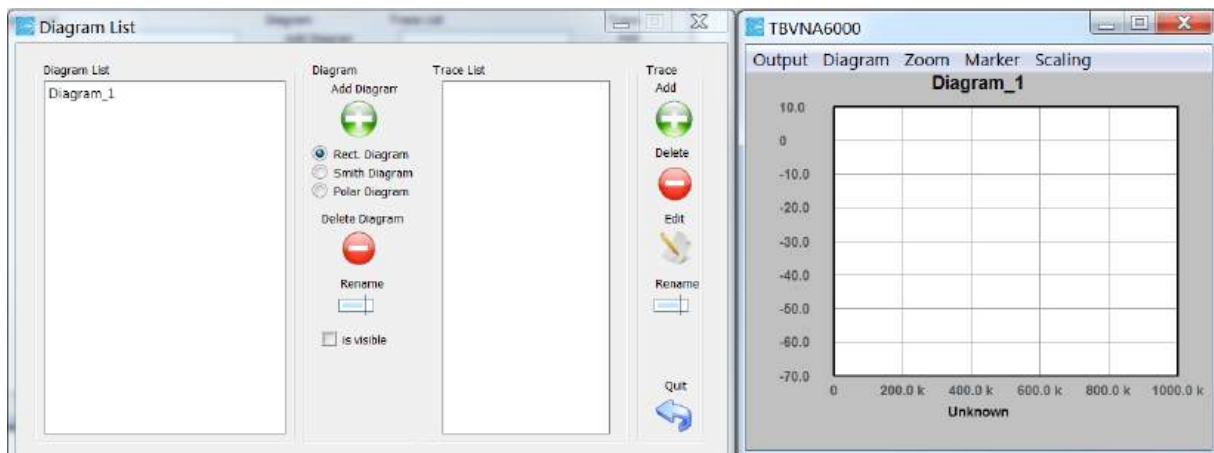

Figure 1-22 Diagram List window with new diagram and a diagram window

After pressing the diagram window, a new Diagram named "Diagram_1" appears in the list and a diagram window opens.

Now press "Add" on the right side in the "Trace" group.

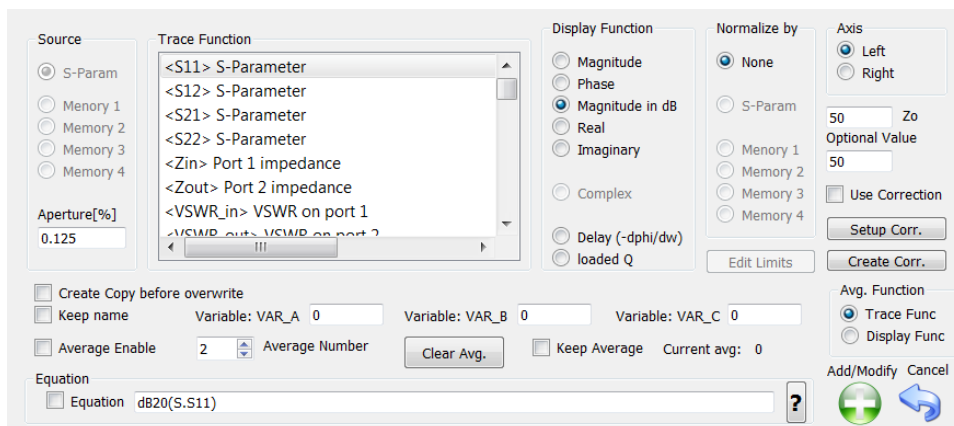

Figure 1-23 Trace Edit Dialog

The Trace Edit - dialog opens and <S11> S-Parameter is preselected.

Now press the Add/Modify button on the right bottom of the window. The dialog disappears.

Press Quit in the "Diagram List" window.

Check the updated diagram on the screen; it should appear similar to the one below.

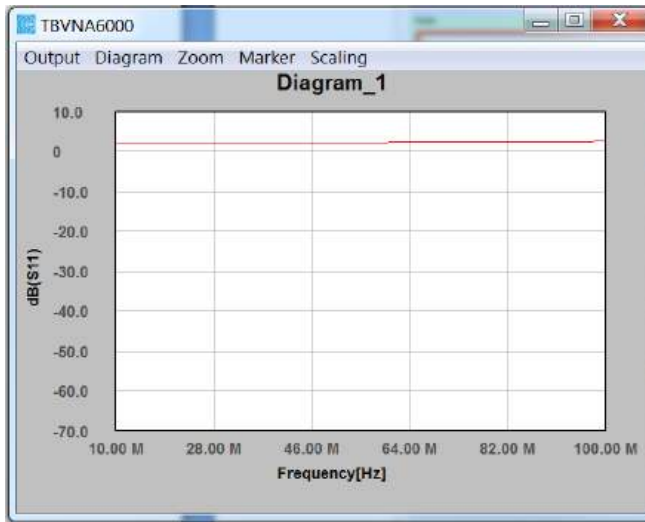

Figure 1-24 Raw $\text{dB}(|S_{11}|)$ measurement from 10 MHz - 100 MHz

You have just completed a raw $\text{dB}(|S_{11}|)$ measurement of Port 1. To update the diagram data, use either the "Single" or "Continue" measurement buttons. Connect a termination to Port 1 and watch the diagram while taking continuous measurements.

1.8 Front Panel Elements.

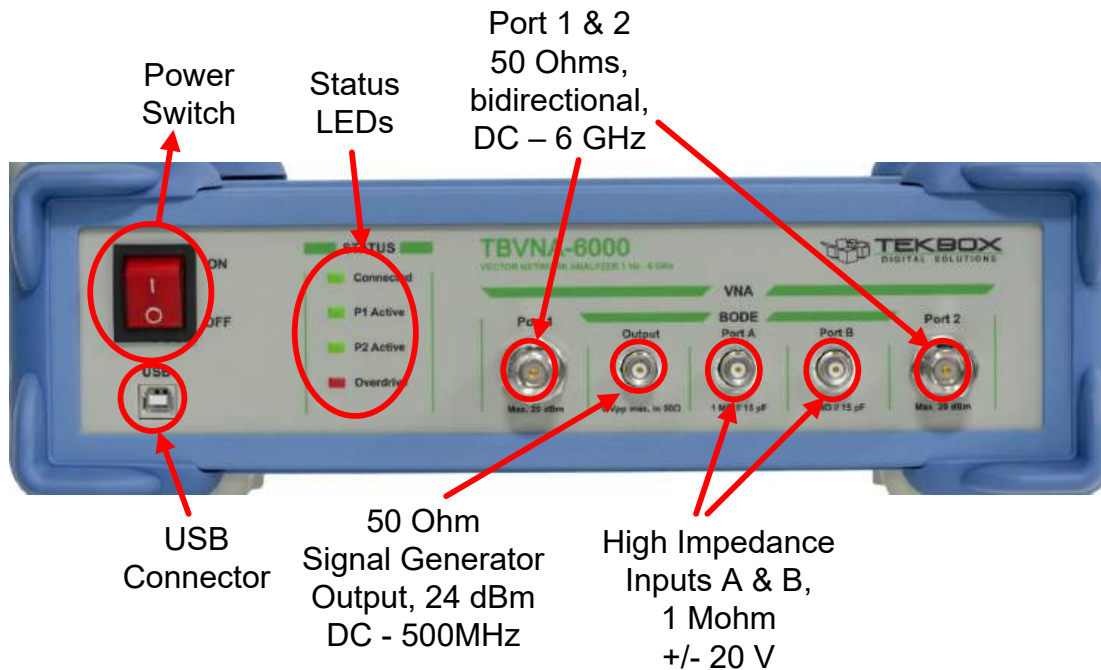



Figure 1-25 Front panel

- Power Switch: Turns the Analyzer on or off
- USB Connector: Connecting the Analyzer to a Computer
- Status LEDs:
 - Connected: indicates, that the USB connection to the control-PC is established
 - P1, P2 active: indicates an ongoing measurement on Port 1 or 2.
 - Overdrive: indicates an RF-input overload condition **during** a measurement, accompanied by buzzer sound
- Port 1 & 2: RF Measurement Ports for the VNA function, can be source or sink and have 50 Ohms input impedance.
- Signal Generator Port: Up to +24 dBm signal output in the range from DC to 500 MHz, will be used as primary output in Bode analyzer mode.
- Port A & B: Inputs with 1 MΩ // 15 pF impedance; 500 MHz max. frequency and up to +/- 20V linear range. These inputs are used in the bode analyzer mode.

	<p>Warning: Maximum RF input power rating</p> <p>The maximum allowed RF input power on Port 1 & 2 is +20 dBm (100 mW or 2.3V RMS) continuous power and on Port A & B max. +/- 25Vp. Be aware this also holds true for short transients or bursts!</p> <p>An overload condition will be only detected during a running measurement!</p> <p>Exceeding the maximum RF input power or voltage will damage the instrument!</p>
---	---

1.9 Theory of Operation

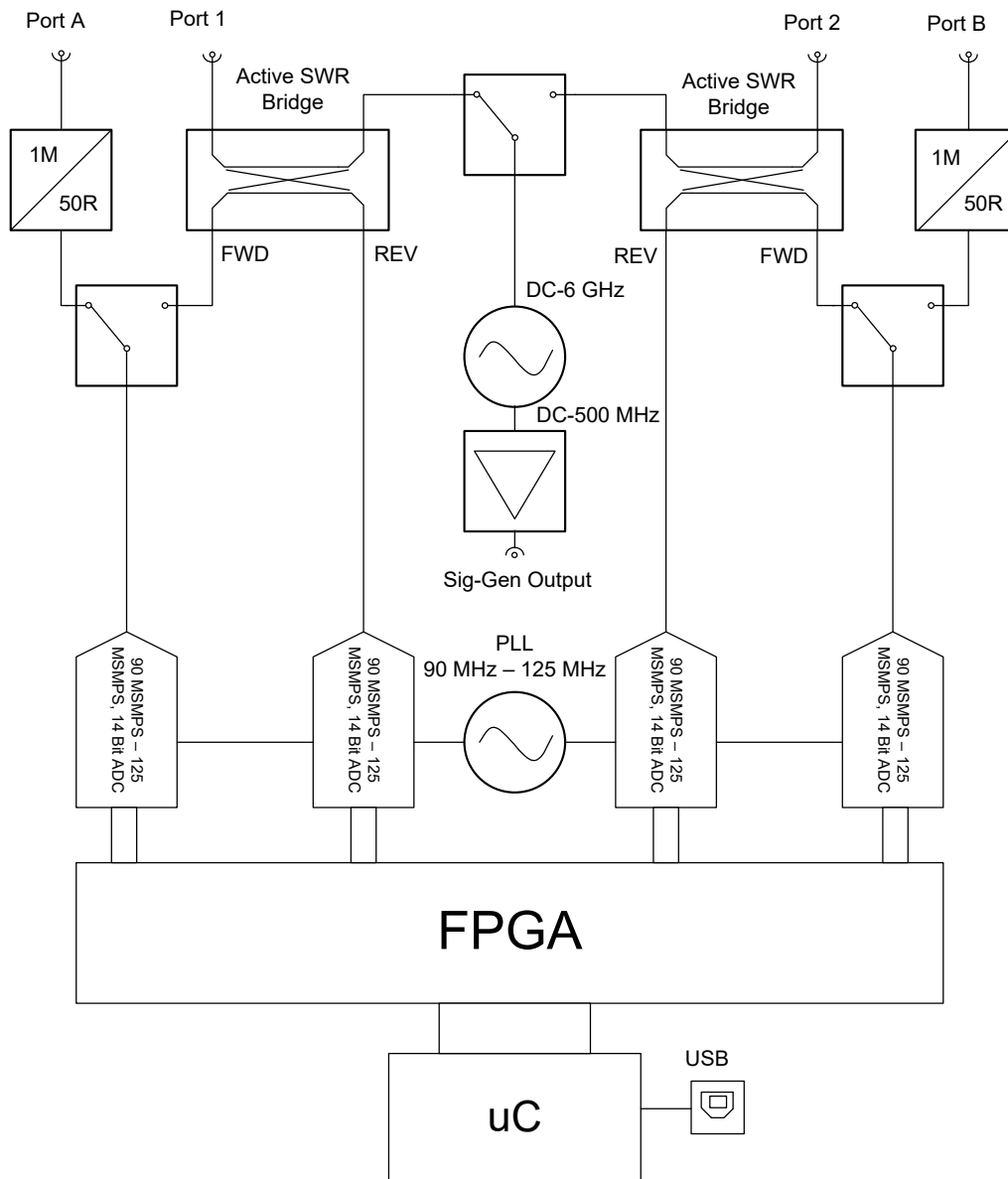

Figure 1-26 System block diagram

Heart of the TBVNA are two active VSWR bridges, which separate the forward wave from the reflected wave. Both bridges are fed by a 6 GHz signal generator via a switch, so that either Port 1 or Port 2 can be used as an output. All 4 outputs of the VSWR bridges are connected to separate AD-converters, which perform sampling and down-conversion in one step. The ADC sampling frequencies are variable and generated by an extra PLL. The FPGA implements digital down-conversion logic and adjustable filtering. The sampled data of the four channels are read out by a Microcontroller and transferred to the PC via USB interface. The "Bode" functionality is implemented by switching each "forward" (FWD) channel either to the corresponding VSWR-bridge or to high impedance "Bode" input ports Port A or B. Furthermore, one portion of the signal generator is fed to the "Output" BNC connector at the front panel and provides a CW output signal in the frequency range 0.001Hz - 500 MHz frequency range and up to +24 dBm output power into a 50 Ohm load.

The analyzer measures four complex waves / voltages: a_1, b_1, a_2, b_2 .

The number denotes the port number the 'a' stand for the forward signal and the 'b' for the reflected signal.

By calculating the complex quotients $b_1/a_1, b_2/a_1, b_1/a_2, b_2/a_2$, voltage independent vectors are derived, which describe the scattering parameters $S_{11}, S_{12}, S_{21}, S_{22}$.

These vectors are not immediately the desired S-Parameters, since they are influenced by the limited accuracy of the VSWR-bridges, switches and cables. Consequently, a calibration procedure is required to eliminate these errors.

One calibration method called "**SOLT**" is implemented in the analyzer's software. This calibration procedure uses four precision known line-elements, to be connected to the analyzer one after another. These standards consist of three single port standards: **Short**, **Open**, **50 Ohms Load** and one two port element called "**Through**".

After consecutively connecting and measuring these standards with the VNA, the analyzer calculates 10 complex calibration coefficients for each frequency point and subsequently corrects for all the errors.

A simpler but much quicker calibration method is normalization of the measured quotients. This can also give good results, if carried out carefully. Normalization can be defined in the trace-edit window.

 Note that a specific calibration will measure a one-port or two-port device at/between the reference plane(s). This virtual plane is shown in the picture below. Any cable in between will affect the measurement, and needs to be de-embedded.

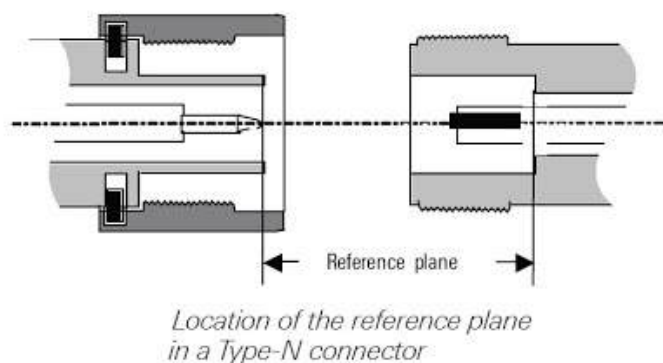

Figure 1-27 Definition of the reference plane.

1.10 Starting the Software

The TBVNA-6000 software can be launched by either double-clicking the desktop icon or by selecting it from the TekBox Program folder. The following window appears upon starting the software:

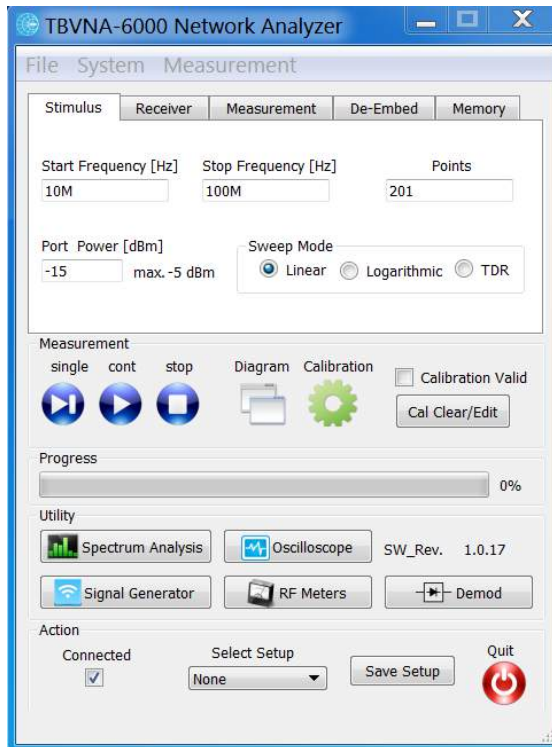

Figure 1-28 Main window, USB connected

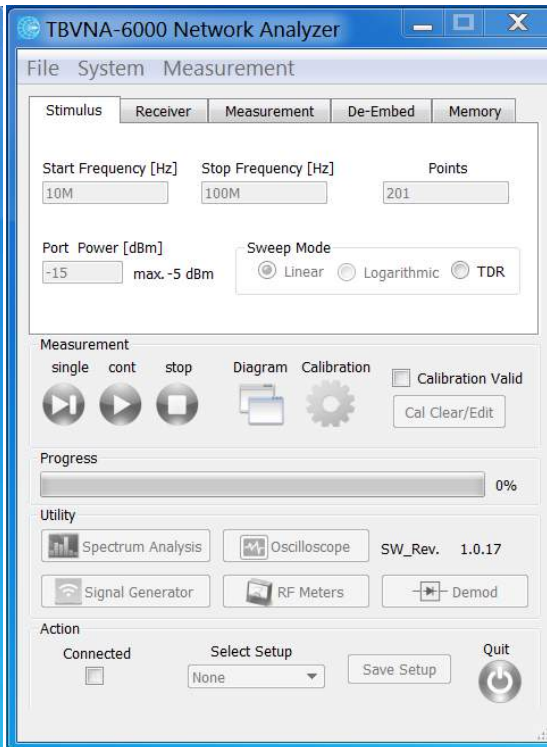

Figure 1-29 Main window, No USB connection

Following command line options are available:

- `-platform windows:dpiawareness=0`
This option allows to scale the GUI in order to display the fonts correctly. Setting this option allows for compensation on font scaling. Use it, if you have an HDR monitor.
- `dark`
This option enables a dark-style GUI display. Please keep in mind that only Windows 10 and Windows 11 will render Windows titles in black.

If a TBVNA-6000 analyzer is detected via USB, the “connected” box will be checked. Otherwise, all application icons will be grayed out and not accessible.

The Quit button will terminate the application.

1.11 Network Analyzer Operation

1.11.1 Stimulus.

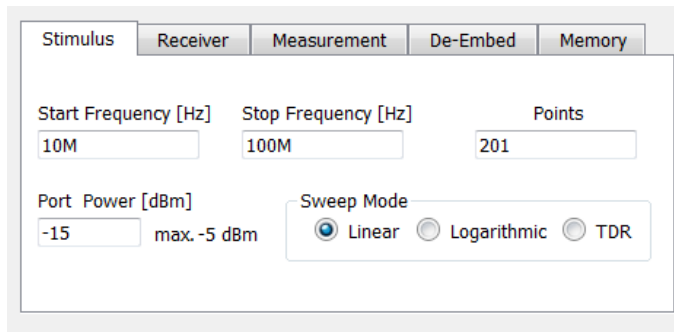

Figure 1-30 Stimulus button group

The stimulus panel is used to control the signal source of the analyzer. Start and Stop frequency parameters need to be typed in Hz. The maximum frequency range is 0.1 Hz to 6 GHz. Any band within this frequency range can be used for measurements with a frequency resolution of 0.01 Hz. The field "points" represents the number of discrete measurements in the specified frequency band. The distribution of the measurement frequency spots can be selected to be linear, logarithmic or TDR. The maximum number of measurement points is 100000, in TDR mode the number must fulfill the number 2^n+1 .

A linear distribution has an equidistant frequency distribution like 1 kHz, 2 kHz, 3 kHz, 4 kHz etc., while a logarithmic distribution like 10 Hz, 100 Hz, 1 kHz, 10 kHz has increasing frequency steps between each measurement point. Logarithmic frequency distributions are very useful for multi-octave measurements.

The button "TDR" is used for low-pass time domain measurements. It will produce a linear distribution like "linear", but the start frequency needs to be 0 Hz. As the analyzer cannot make a measurement at 0 Hz, which is required for the time domain transformation, the 0 Hz measurement point will be replaced by a fitting low frequency measurement. The "TDR" option is ONLY used for low-pass time domain measurements.

The Port Power reflects the calibrated output power of the active port during measurement. It can be set between -5 dBm to -80 dBm. A port level of -15 dBm is recommended for most applications. A lower output power will increase noise while a higher power than -7 dBm may not be possible in some frequency bands but will lower the noise floor. In this case the output power may be unlevelled.



Please note that changing start-frequency, stop-frequency, points or distribution, may render an active calibration invalid, since the calibration is made for every frequency point. If an interpolation is possible a corresponding window will inform the user. Changing the output power may slightly change the accuracy of the measurement, but will not invalidate a calibration.

1.11.2 Receiver Section

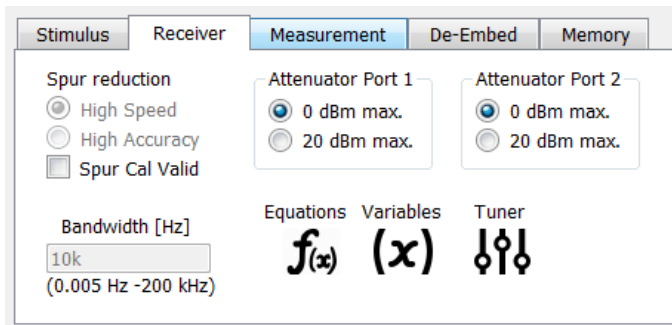

Figure 1-31 Receiver Section

The network analyzer uses four isolated receiver chains to measure the 2-port S-parameters. The bandwidth of the receivers can be adjusted to be within about 0.005 Hz and 200 kHz. A narrower bandwidth decreases noise, resulting in a higher signal-to-noise ratio; however, a reduced bandwidth also increases the measurement time.

For low frequency measurements the system will automatically set a suitable bandwidth, which means that the entered value can be considered as upper limit of the applied bandwidth. Although the bandwidth can be entered in arbitrary steps, the effective bandwidth will follow 2^n steps, like 1 Hz, 2 Hz, 4 Hz, 8 Hz etc. and the closest value will be chosen. The bandwidth can be changed anytime without invalidating the active calibration.

The VNA has a built-in spurious reduction, which effectively eliminates discrete frequency spurious signals produced by the signal generators harmonics and higher order mixing products. The "High Accuracy" mode will eliminate any possible spurious peak at the cost of increased measurement time. The reduction is accomplished by dithering the internal sampling clocks. When setting up spurious reduction in the calibration menu, the necessary sweeps for a measurement are reduced from three to two. Furthermore, in a calibrated measurement environment a spur pre-calibration will significantly increase accuracy.

To adjust the dynamic range of measurements, the maximum input power for port 1 and 2 can be adjusted. In case of measuring amplifiers with a high gain, it is a better choice to set the 20 dBm input attenuator than lowering the port power, since lowering the port power will introduce noise.

Further this tab allows to create and use global-equations. These equations can be entered when the "Equation" button is pressed. Global equations are more powerful than local equations, which can be defined within diagrams and only can access trace data.

Global equations can also access data such as marker values and can contain parameters, which can be tuned.



Figure 1-32 Global equations

Equations can be added or deleted and will be saved with the setup. These global equations can be used later as an input for trace equations. The "?" button will pop up an equation reference syntax description to support the input process.

The next button is labelled "Variables" and implements a list of numeric values with a certain name. These variables may be used in equations as a data source with the syntax : VAL.<name>. The purpose of these values is to store values that may be altered during the measurement process. Although global-equations can also be used to define values, these values are unique since they can be tuned.

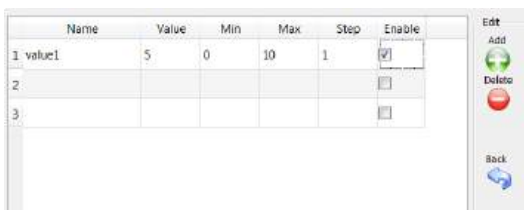

Figure 1-33 Tuneable Values

The "Value" field contains the actual parameter value and the Min and Max fields define the tuning range. The step field specifies the step size of the tuning, while the Enable checkbox enables or disables tuning.

The Variables spreadsheet is the direct input to the "tuner" dialog. Press the "Tuner" button to open it.

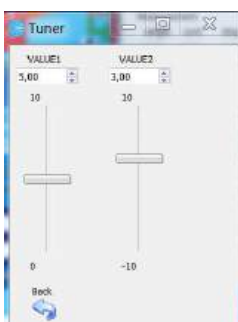

Figure 1-34 Tuner Dialog

The tuner dialog allows you to modify the value of each variable in real time by sliding the associated slider. Now it is evident what the min/max/step fields in the variables spreadsheet are for.

1.11.3 Measurement Section

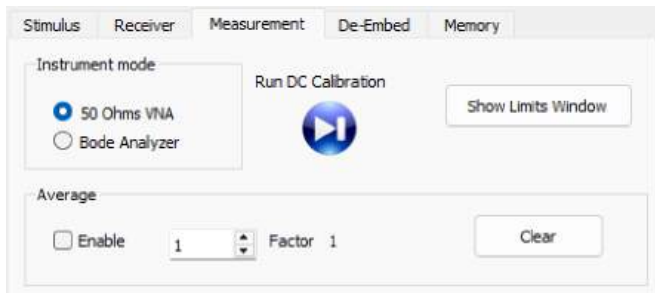

Figure 1-35 Measurement Section

The measurement section allows to select the analyzer mode. With "50 Ohms VNA" checked, the analyzer operates as 6 GHz vector network analyzer. In "Bode Analyzer" mode (only available with Option BODE) it operates as a gain phase meter and vector voltmeter. In this mode, the signal output is routed to the BNC connector "OUT" at the front panel. The frequency range is limited to 500 MHz. The maximum output power is +24dBm up to 200 MHz and + 10 dBm from 200 MHz to 500 MHz.

In Bode-mode, the stimulus section of the analyzer is disabled and all frequency, bandwidth and power settings are entered into the "Bode Sweep List" window. This window pops up upon selecting "Bode Analyzer" mode.

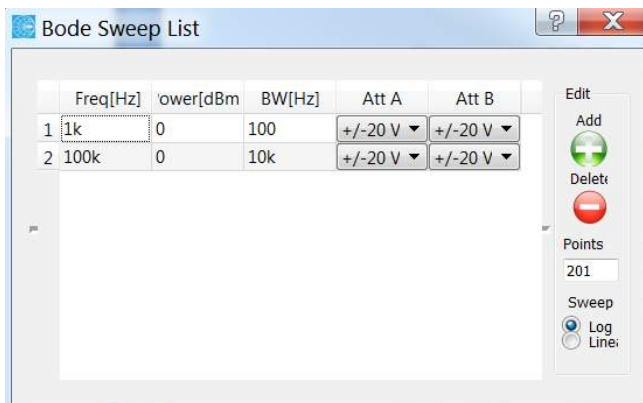

Figure 1-36 Bode Sweep List

In "Bode" Mode all 4 channels are available as a receiver inputs. Port 1 & 2 and Port A & B. Port 1 & 2 offer 50 Ohm input impedance at a reduced maximum input range of 0 dBm. Port A & B offer a high input impedance and input voltage ranges of +/-20V , +/-5V or +/-0.5V for each frequency segment.

"Run DC calibration" can be used to manually to increase the dynamic range at frequencies close to zero Hz. In normal operation, the analyzer automatically carries out DC compensation from time to time.

The "Show Limits Window" button can be pressed to display production-test limits. This is particularly convenient if the limits test window has been closed before.

If averaging is enabled the analyzer starts coherent averaging of S-parameter. Measurement accuracy and noise floor is improved at the cost of measurement time. Select the number of

measurements cycles to be averaged. If necessary the averaging can be restarted by pressing the "Clear" button. Averaging is implemented as a gliding mean filter.

The instrument may measure in two distinct ways:

1.11.4 De-Embed Section

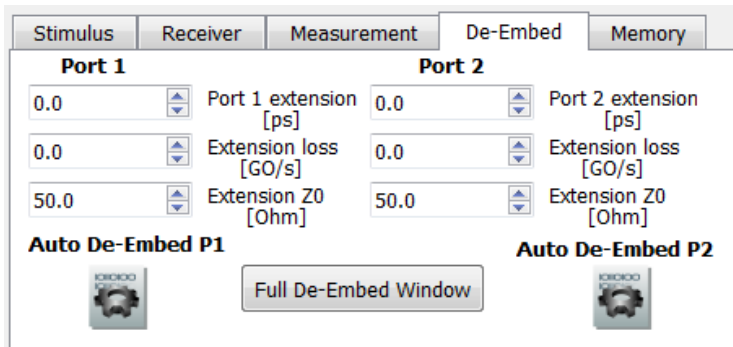

Figure 1-37 De-embed section

Although the analyzer does full S-Parameter de-embedding, there is an additional simple line extension feature, which can be controlled during measurement. This feature is used to extend (or shrink) a virtual transmission line attached to each port's calibration plane. By careful adjustment a physically attached transmission line can be eliminated in measurements by using negative delay values. The transmission line length must be entered in picoseconds, further loss and the characteristic impedance of the transmission line can also be adjusted. By pressing the "Full De-Embed" button the De-Embedding dialog will pop up. The same function can be selected in the main windows drop down menu. The Auto De-Embed P1/P2 button will open another two windows:

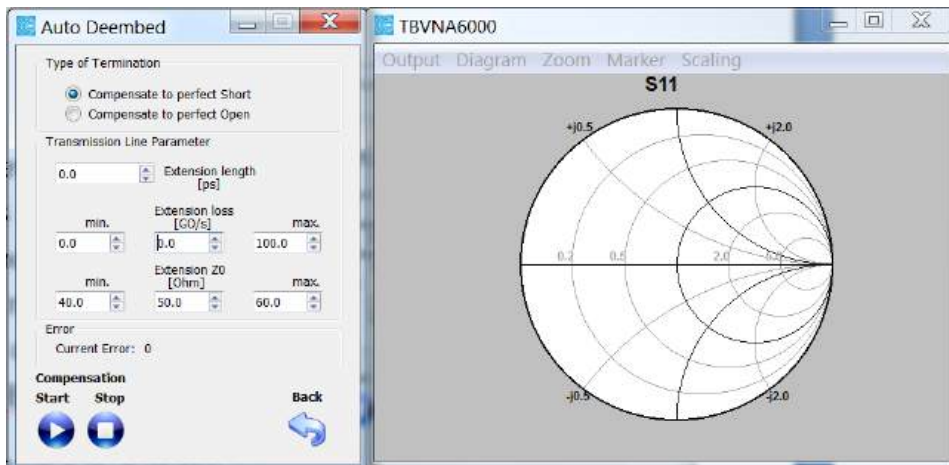

Figure 1-38 Auto De-Embed Windows

The Auto-De-Embed function adds flexibility to a standard calibration, when additional transmission lines are inserted. Attach a short or open to a transmission line. Then perform a measurement and start to compensate either for a perfect short or open. The software will try to find the optimum parameters for the closest match. When clicking "Back" the calculated values will be transferred to the corresponding fields in the window.

1.11.5 Memory Section

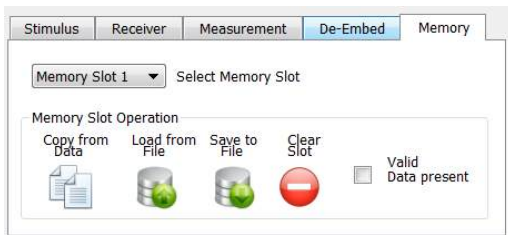

Figure 1-39 Memory section

Four memory slots are available to store S-Parameters as a reference used in Trace measurement functions. S-Parameter files can be imported from a drive or copied from the current measurement. As can be seen in the above, every memory slot can be edited and slot data can be even saved to disk. (Touchstone format). The "Clear Slot" button will delete all slot data.

1.11.6 Measurement Panel



Figure 1-40 The Measurement Panel

The buttons "single", "cont" and "stop" control the measurement. "Single" will initiate a single measurement, while "cont" will perform continuous sweeps. After each sweep any diagrams and traces will be updated. The "stop" button interrupts a continuous measurement.

The diagram button gives access to all diagram related lists, diagrams and traces.

The "Calibration" button opens the path to all calibration related submenus.

The "Calibration valid" checkbox indicates the presence of calibration data. Precision measurements can only be made with an active calibration. "Cal Clear/Edit" allows to select the current calibration or to clear an active calibration. Alternatively, calibration files can be accessed via the file menu.

1.11.7 Progress Bar and Utilities

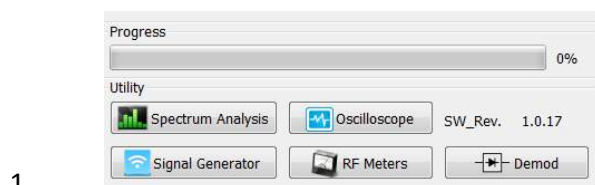

1

Figure 1-41 Progress Bar and utility group

The analyzer features many utilities, which can be invoked by the corresponding buttons. This utilities are documented in chapter 1.16. The progress bar shows the progress of ongoing measurements.

1.11.8 Action Group

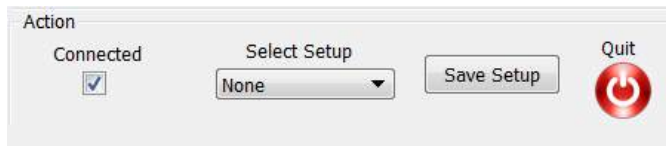

Figure 1-42 Action Group

If the device is connected to the PC upon starting the analyzer application, the software will automatically attempt to establish a connection. The "Connected" checkbox indicates the connection status.

The "Setup Selector" enables loading of predefined setups. These setups contain measurement setups, calibration data, diagrams and traces. The "Save Setup" button allows to save the current measurement setup. Alternatively, setup files can be accessed via the file menu

The "Quit" button closes the application. Be sure to save all data before quitting the program.

1.12 Network Analyzer Calibration

The accuracy of a network analyzer depends on the quality of its calibration. Every setup needs an individual calibration. The calibration is performed by using precision calibration standards:

- Open (male and female)
- Short (male and female)
- Load (male and female)
- Through (male and female)

A single port calibration uses only the Open, Short and Load standard, while a full two-port calibration utilizes all four standards.

The Open standard represents an open transmission line, while the Short standard is shorted transmission lines. The Load standard is a 50 Ω termination. The Through standard is an unterminated 50 Ω transmission line. These standards have very accurately characterized length, impedance and parasitic components.

The TBVNA-6000 software provides two methods to define calibration standards:

- Equation driven
- S-Parameter driven

The equation driven standards are represented by parameters such as transmission line delay, loss, impedance etc. while the S-Parameter definitions simply use supplied S-Parameter files in Touchstone(c) .s2p format.

The TBVNA software provides a guided calibration procedure to simplify and organize the process.

1.12.1 Calibration Type

Start the calibration process by selecting the frequency range, number of points, sweep type and signal power in the Stimulus section, then press the "Calibration" button.

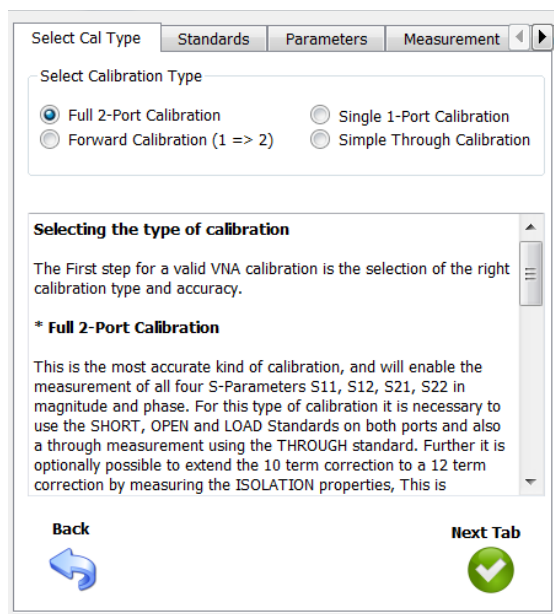

Figure 1-43 Calibration window

Next select the required Calibration Type:

*** Full 2-Port Calibration**

This is the most accurate calibration, requiring the measurement of all four S-parameters in magnitude and phase: S11, S12, S21, and S22. It is necessary to apply the SHORT, OPEN and LOAD Standards on both ports and carry out a through measurement using the THROUGH standard. Optionally, the 10-term correction can be expanded to a 12 term correction by measuring the ISOLATION properties. This is performed by terminating both ports with a LOAD standard.

*** Single 1-Port Calibration**

This calibration type only allows accurate impedance/reflection measurements on Port 1. It requires SHORT, OPEN and LOAD standards. In comparison to the full 2-port calibration, the measurement time is reduced by half.

*** Forward Calibration**

This calibration type accurately calibrates Port 1 impedance utilizing SHORT, OPEN, and LOAD, and normalizes the S21 parameter to the THROUGH standard. The Forward calibration does not include S12 and S22, therefore it will only approximate S11 and S21. The S11 and S21 measurements may be affected by the VNA's non-ideal input impedance on Port 2. The advantage of this type of correction technique is that it reduces measurement time by half compared to full 2-Port correction and requires less time to change and measure calibration standards, while still providing a good insight into two-port behavior.

*** Simple Through Calibration**

This is the least accurate, but fastest calibration method. It just compensates for the THROUGH standard and is used to measure transfer functions of filters and similar. There will be no impedance measurements possible. However, it is still superior than a basic trace normalization.

After selecting the calibration type press "Next Tab"

1.12.2 Calibration Standards Tab

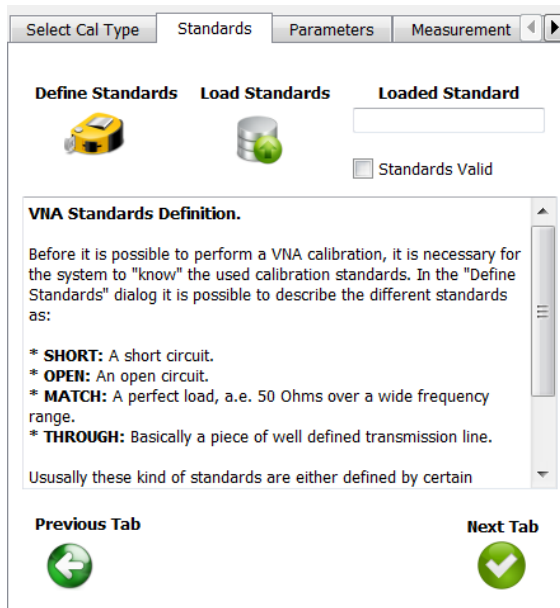

Figure 1-44 Calibration window, Standards Tab

Prior to a VNA calibration, the system must "know" the properties of the relevant calibration standards. In the "Define Standards" dialog, you can characterize the different standards as:

- * **SHORT**: A short circuit
- * **OPEN**: An open circuit
- * **MATCH**: A perfect load, a 50 Ohm termination over a wide frequency range.
- * **THROUGH**: Basically a piece of well-defined transmission line.

These standards are either characterized by their parasitic parameters or loaded as an S-Parameter file. Both options are viable.

However, it is impossible to calculate the calibration coefficients without first setting up the calibration standards or selecting predefined standards from a list.

Tekbox offers an assortment of calibration kits as well as the appropriate standard definition files. Use the button "Load Standards" to select and load the definition file into the software. The software also provides an "IDEAL" standard file with neither loss nor delay. This type of calibration is appropriate when no connectorized standard can be utilized and calibration precision is less important.

Once the standard is properly loaded, a checkbox indicates "Standards valid" and the name of the standard is shown in the "Loaded Standard" field.

It is also possible to configure third party standards by pressing the "Define Standards" button.

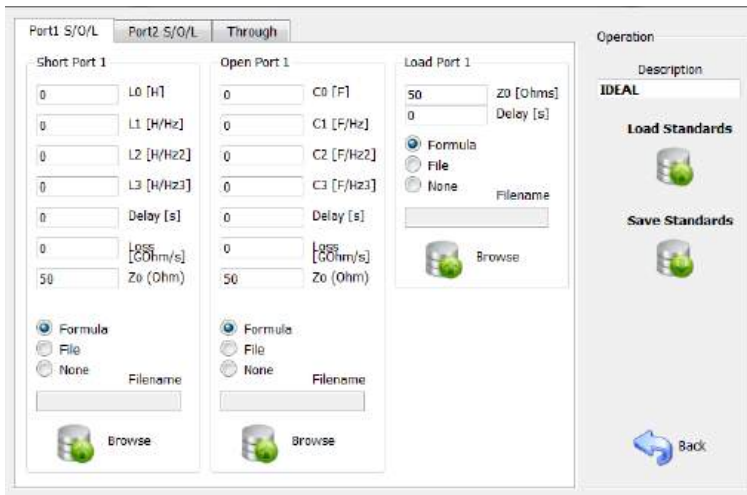

Figure 1-45 Calibration window, Standards Definition

There, you may insert the standard's parameters or utilize an S1P or S2p touchstone compliant scattering parameter file for each Port and for Through.

After entering all standard parameters, save the data to calibration standard file.

1.12.3 Calibration Parameter Tab

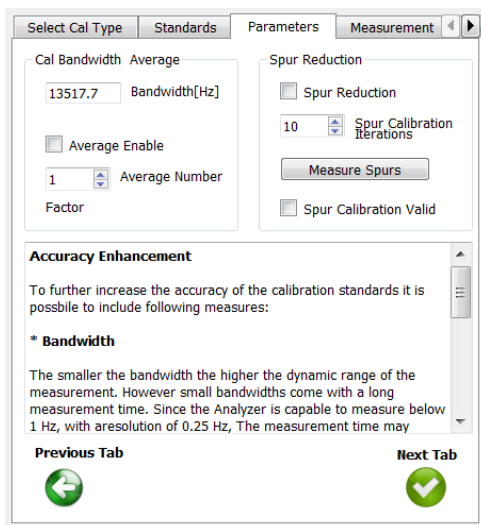

Figure 1-46 Calibration window, Parameter Tab

The parameter tab allows to adjust bandwidth and averaging settings used during the measurement of the calibration standards. This enables for a more accurate calibration. Spur Reduction can be used to improve calibration by detecting and eliminating down conversion mixing products. However, Spur reduction comes with a 200 % to 300 % increase in measurement time.

1.12.4 Calibration Measurement Tab

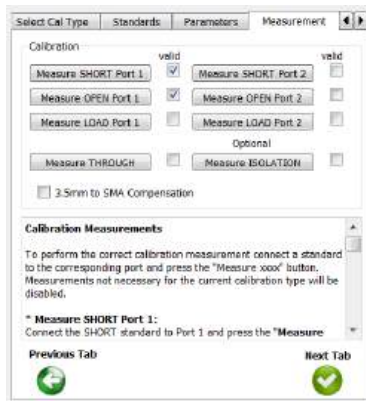

Figure 1-47 Calibration window, Measurement Tab

The measurement tab displays a push-button for each required calibration standard measurement. The measurement tab shows a push-button for each required calibration standard measurement. Connect the desired calibration standard to the TBVNA and then press the corresponding push-button to start the measurement. Following a successful measurement, the "valid" checkbox is selected. Any Push-Button can be hit many times if a re-measurement appears to be necessary. If all of the requisite "valid" checkboxes are checked, the calibration measurements are complete. The isolation measurement is optional and may extend the dynamic range of the calibration. If 3.5 mm calibration standards are used on SMA cables, the "3.5 mm to SMA Compensation" option can be selected to improve calibration accuracy.

After a successful measurement, the "valid" checkbox is checked. Any Push-Button may be pressed several times, if a re-measurement seems required. If all required "valid" checkboxes are marked, the calibration measurements are finished. The Isolation measurement is optional and may increase the dynamic range of the calibration. If 3.5 mm calibration standard are used on SMA cables, the "3.5 mm to SMA Compensation" checkbox may be checked to increase the calibration accuracy.

1.12.5 Calibration Calculate Tab



Figure 1-48 Calibration window, Calculate Tab

The final step is to press the "Calculate Calibration Coefficient" button. This will create the calibration data set for consecutive measurements. When the "Cal Coeff valid" Checkbox is ticked, the calibration procedure is complete. It is recommended to save the coefficients, since calibration takes time and the coefficients can be reused for future measurements.

Please Note:

The calibration will become invalid if:

- * the frequency range changes
- * the calibration type changes
- * the sweep mode changes
- * the Attenuator changes
- * the instrument mode changes

However the change of bandwidth and port power will not invalidate a calibration, but may reduce the accuracy.

The TBVNA interpolates new calibration coefficients whenever possible, such as after changing the number of frequency points or changing frequency span. If the original calibration data is required again, it may be loaded via the menu (File-> Load Calibration) or by clicking the cal clear/edit button on the main window

1.12.6 The Cal Clear/Edit Push Button in the main window

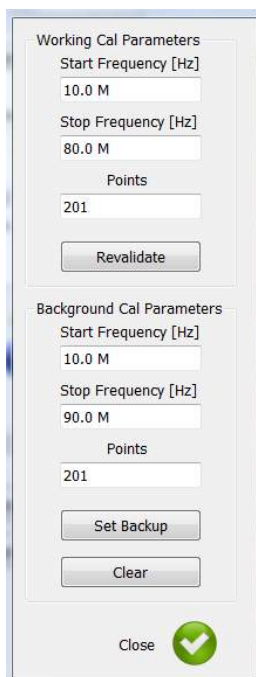



Figure 1-49 Cal Clear/Edit Window

The Cal Clear/Edit window allows simple manipulation of the active calibration. Usable Calibration Parameters can be interpolated from the original calibration data in the background memory. If a calibration accidentally becomes invalid, the original Calibration Parameters can be restored by pressing the "Revalidate" button. To restore the original background calibration, press the "Set Backup" button. It will overwrite the working calibration parameters with the background parameters. The "Clear" button deletes all calibration data.

 "Save Setup" will save the calibration data along with diagrams, traces and all other configuration data.

It is possible to perform measurements with the VNA with or without a valid calibration by pressing one of the blue "Measurement" buttons. The "single" button will initiate a single measurement, while "cont" starts continuous measurements. The "stop" button stops an ongoing continuous measurement.

 Raw data of uncalibrated measurements can be utilized for normalization purpose. This can be done with the VNA, but would typically be applied to normalize measurements done with the Bode analyzer.

1.12.7 Bode calibration

In the "Bode" analyzer mode, normalization replaces calibration. Use Memory data slots 1-4 to store reference sweeps, such as for example a through connection between the BNC OUT Port and Port A or Port B. These reference sweeps can then be used to normalize measurement data or the results of measurement equations.

1.13 Measurements and Diagrams

By pressing the the "Diagram" button on the main window, the Diagram/Trace dialog will pop up.

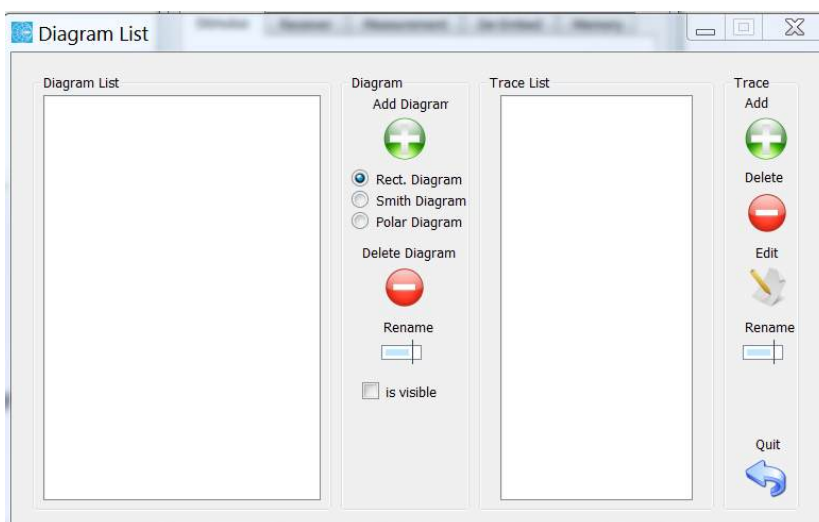

Figure 1-50 Diagram/Trace Dialog

First choose the desired diagram style –Rectangular Diagram, Smith Diagram or Polar Diagram – and press the “Add Diagram” button.

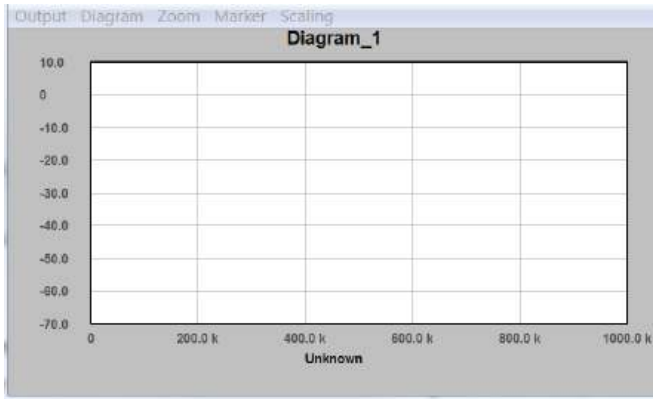

Figure 1-51 Default Rectangular Diagram

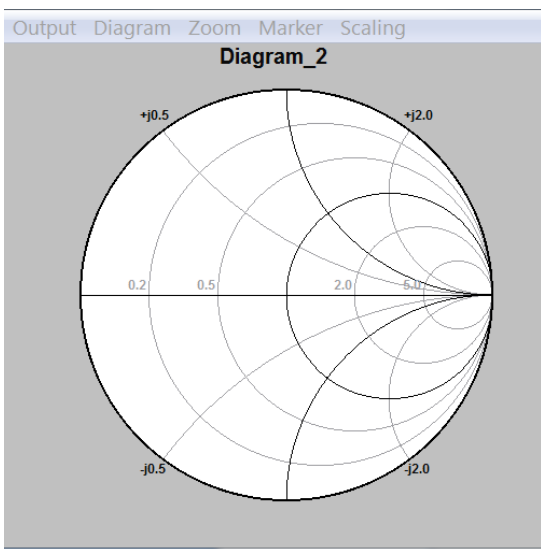

Figure 1-52 Default Smith Diagram

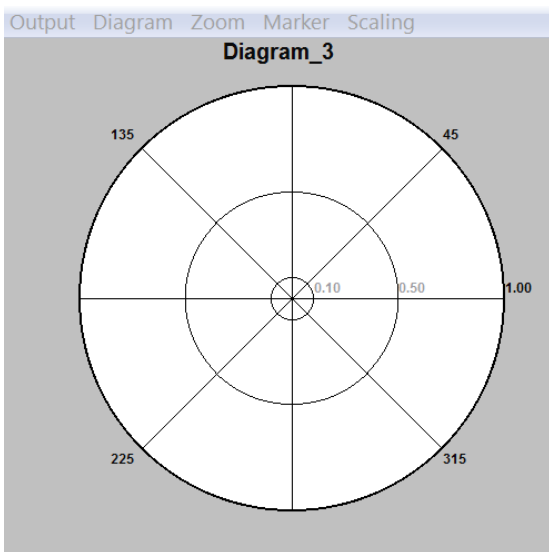

Figure 1-53 Default Polar Diagram

Click at the diagram in the diagram list and then hit the “Add Trace” button to assign a measurement to the diagram.

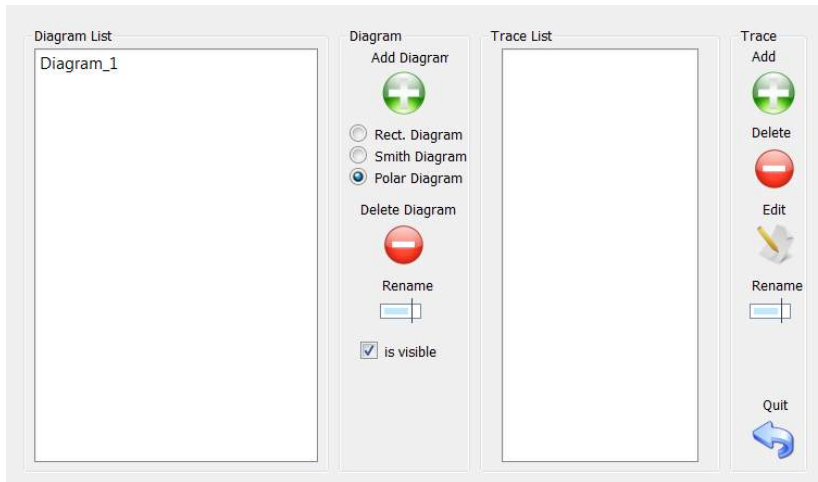

Figure 1-54 Diagram List

The name of the diagram can be changed by selecting the diagram's name in the "Diagram List" and then pressing the "Rename" button.

! The diagram type such as "rectangular", "smith" or "polar" cannot be changed after creating the diagram. You can only delete it and create a new diagram.

! Closing a diagram will make the diagram invisible, although all data is retained. Select a diagram in the diagram list and click the "is visible" checkbox to make the window re-appear.

Upon pressing the “Add Trace” button, the Trace Edit dialog window opens.

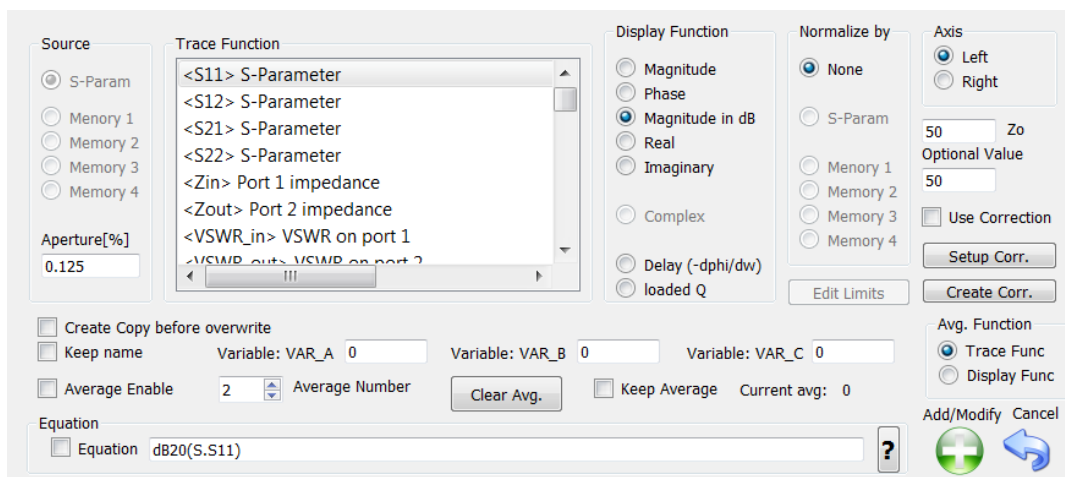

Figure 1-55 Trace Edit Dialog

The trace definition process starts from the left window side and ends at the right end of the dialog.

1. Select a source for the trace. By default, this are the actual measured S-Parameters or one of four memory slots, which can be loaded in the main-windows menu. Unavailable sources are grayed-out.



It is necessary to make at least one measurement or load S-Parameter data from a file into a memory slot, in order to create a trace.

2. Select the Trace Function (VNA mode). Numerous graph traces can be derived from the measurement data.

Trace Function	Description
<S11> S-Parameter	S_{11} scattering parameter
<S12> S-Parameter	S_{12} scattering parameter
<S21> S-Parameter	S_{21} scattering parameter
<S22> S-Parameter	S_{22} scattering parameter
<Zin> Port 1 impedance	Complex impedance at Port 1 with termination on Port 2
<Zout> Port 2 impedance	Complex impedance at Port 2 with termination on Port 1
<VSWR_in> VSWR on port 1	Voltage standing wave at Port 1 with termination on Port 2
<VSWR_out> VSWR on port 2	Voltage standing wave at Port 2 with termination on Port 1
<Gvf> matched voltage gain forward	Complex V_2/V_1 voltage ratio with termination on Port 2
<Gvr> matched voltage gain reverse	Complex V_1/V_2 voltage ratio with termination on Port 1
<Gif> matched current gain forward	Complex I_2/I_1 current ratio with termination on Port 2
<Gir> matched current gain reverse	Complex I_1/I_2 current ratio with termination on Port 1
<k> stability factor	Stability of a two port if $k > 1$
<Gms> maximum stable gain	Maximum stable gain of a two port
<Gmax> maximum available gain	Maximum available gain of a two port
<Gvfo> open output voltage gain forward	Complex V_2/V_1 voltage ratio with open Port 2
<Gifs> short output current gain forward	Complex I_2/I_1 current ratio with open Port 2
<Gvfa> arbitrary load output voltage gain forward (use optional value)	Complex V_2/V_1 voltage ratio with resistance on Port 2 given by the optional input field.
<Gifa> arbitrary load output current gain forward (use optional value)	Complex I_2/I_1 current ratio with resistance on Port 2 given by the optional input field.
<series RC> R-C in series equivalent, Real = R, Imag = C	Calculates R-C equivalent series circuit from S_{11} . Resistance in Ohm is the real-value, capacitance in farad is the imaginary value.
<parallel RC> R-C in parallel equivalent, Real = R, Imag = C	Calculates R-C equivalent parallel circuit from S_{11} . Resistance in Ohm is the real-value, capacitance in farad is the imaginary value.
<series LR> R-L in series equivalent, Real = R, Imag = L	Calculates R-L equivalent series circuit from S_{11} . Resistance in Ohm is the real-value, Inductance in Henry is the imaginary value.
<parallel LR> R-L in parallel equivalent, Real = R, Imag = L	Calculates R-L equivalent parallel circuit from S_{11} . Resistance in Ohm is the real-value, Inductance in Henry is the imaginary value.
<Z11> Z-Parameter	Z_{11} impedance parameter
<Z12> Z-Parameter	Z_{12} impedance parameter
<Z21> Z-Parameter	Z_{21} impedance parameter
<Z22> Z-Parameter	Z_{22} impedance parameter
<A> ABCD-Parameter	A - ABCD parameter.
 ABCD-Parameter	B - ABCD parameter.
<C> ABCD-Parameter	C - ABCD parameter.
<D> ABCD-Parameter	D - ABCD parameter.
<TDR_S11_LP_RW>	Time Domain converted S_{11} parameter, using a low pass characteristics, DC - fmax conversion using no window function.
<TDR_S11_LP_HW>	Time Domain converted S_{11} parameter, using a low pass characteristics, DC - fmax conversion using a Hamming window function.
<TDR_S11_BP_RW>	Time Domain converted S_{11} parameter, using a band pass characteristics, fmin - fmax conversion using no window function.
<TDR_S11_BP_HW>	Time Domain converted S_{11} parameter, using a band pass characteristics, fmin - fmax conversion using Hamming window function.

Figure 1-56 Available Measurement functions

Trace Function	Description
<TDR_S21_LP_RW>	Time Domain converted S_{21} parameter, using a low pass characteristics, DC - fmax conversion using no window function.
<TDR_S21_LP_HW>	Time Domain converted S_{21} parameter, using a low pass characteristics, DC - fmax conversion using a Hamming window function.
<TDR_S21_BP_RW>	Time Domain converted S_{21} parameter, using a band pass characteristics, fmin - fmax conversion using no window function.
<TDR_S21_BP_HW>	Time Domain converted S_{21} parameter, using a band pass characteristics, fmin - fmax conversion using Hamming window function.
<TDR_S12_LP_RW>	Time Domain converted S_{12} parameter, using a low pass characteristics, DC - fmax conversion using no window function.
<TDR_S12_LP_HW>	Time Domain converted S_{12} parameter, using a low pass characteristics, DC - fmax conversion using a Hamming window function.
<TDR_S12_BP_RW>	Time Domain converted S_{12} parameter, using a band pass characteristics, fmin - fmax conversion using no window function.
<TDR_S12_BP_HW>	Time Domain converted S_{12} parameter, using a band pass characteristics, fmin - fmax conversion using Hamming window function.
<TDR_S22_LP_RW>	Time Domain converted S_{22} parameter, using a low pass characteristics, DC - fmax conversion using no window function.
<TDR_S22_LP_HW>	Time Domain converted S_{22} parameter, using a low pass characteristics, DC - fmax conversion using a Hamming window function.
<TDR_S22_BP_RW>	Time Domain converted S_{22} parameter, using a band pass characteristics, fmin - fmax conversion using no window function.
<TDR_S22_BP_HW>	Time Domain converted S_{22} parameter, using a band pass characteristics, fmin - fmax conversion using Hamming window function.
<Gtp> Transducer Gain	Calculates the two port transducer gain using an arbitrary output Port 2 load defined by the optional value
<Q> Quality factor	Calculates the Quality factor from the S_{11} parameter. (Divides imaginary impedance by real impedance)
<IMP series>	Impedance measurement, series method
<IMP shunt>	Impedance measurement, shunt method

Figure 1-57 Cont. Available Measurement functions

In Gain / Phase Meter/ Bode mode (BODE option required), following traces / measurements are available.

Trace Function	Description
<CH 1>	Voltage Channel 1
<CH 2>	Voltage Channel 2
<CH A>	Voltage Channel A
<CH B>	Voltage Channel B
<CH A / CH B>	Channel A to Channel B ratio
<CH B / CH A>	Channel B to Channel A ratio
<CH A / CH 1>	Channel A to Channel 1 ratio
<CH A / CH 2>	Channel A to Channel 2 ratio
<CH 1 / CH A>	Channel 1 to Channel A ratio
<CH 2 / CH A>	Channel 2 to Channel A ratio
<CH B / CH 1>	Channel B to Channel 1 ratio
<CH B / CH 2>	Channel B to Channel 2 ratio
<CH 1 / CH B>	Channel 1 to Channel B ratio
<CH 2 / CH B>	Channel 2 to Channel B ratio
<CH 1 / CH 2>	Channel 1 to Channel 2 ratio
<CH 2 / CH 1>	Channel 2 to Channel 1 ratio

Figure 1-58 Cont. Available Measurement functions for Option BODE

2) Select the Display Function. The Display function will be applied on the Trace-Function (TF).

Display Function	Description
Magnitude	Equals to $ TF $ or $\text{abs}(TF)$
Phase	Equals to $\text{arg}(TF)$ in Degrees
Magnitude in dB	Equals to $10 \cdot \log(TF)$ or $10 \cdot \log(\text{abs}(TF))$
Real	Equals to $\text{real}(TF)$
Imaginary	Equals to $\text{imag}(TF)$
Complex	Only used in Smith diagrams and equals to TF
Delay	Equals to $-d\phi/d\omega$, the derivation of phase over frequency
Loaded Q	Equals to $-d\phi/d\omega \cdot \omega/2$

Figure 1-59 Available Display Functions

4. Select a source to normalize measurement. This can be used for simple calibration, or other relative measurements.
5. Select axis for rectangular diagram. Since rectangular diagrams may have a right or left Y-axis the function can be assigned to either of them.
6. Set options: For Delay and loaded Q Measurement the Aperture can be set, to get a less noisy result. Default is an aperture size of 0.125% of the total frequency range. Some trace functions need an optional value, which can be set in the optional field. Further the system Z_0 can be set to a specific value. All subsequent calculations will use this characteristic impedance Z_0 as a basis.

The "Create Copy before overwrite" checkbox will configure the instrument to create a copy of the current trace after each sweep. This creates a set of traces to monitor trends, as an example. The copies are solely graphs, which will not be updated by a sweep.

The "Keep name" checkbox configures the trace to keep the given name. Whenever a trace is modified the system will assign it a derived trace name, such as "equation" for equations. When the trace name is altered the new name may be overwritten on the next trace edit. Keep name will assure that the given name will stick to the trace.

The "Average Enable" check box will enable a "per trace" local averaging function compared to the global averaging function. Following GUI elements are related to the averaging function:

- Average number
This is the number of trace data used for the average.
- Clear Average
Instantly clears the average memory and shows the current measurement data
- keep average
Usually, a fresh measurement (single or continuous) clears the average memory. By selecting this option, the average values are saved in the memory. If the measurement function is changed, make sure that the average memory is erased before the next measurement.

- current average

Displays how many sweeps are currently used to calculate the average trace.

- Avg. Function

Allows the user to choose where the average is applied in the measuring process.

Trace Function: The Average is applied to the Trace Function (e.g. S11) and then the Display Function is applied to the average. It improves SNR.

Display Function: The Average is applied after the calculation of the display function. For example dB(S11). This type of average will smoothen the trace, but will not increase SNR.

1.13.1 The Equation Editor

Unlike defining an output trace by selecting all 6 steps like in the last chapter it is possible to define an output equation, which will be used to generate the display trace. The equation can be entered in the text field, and activated by checking the "Equation" check box.

The equation editor supports following standard operators, with declining binding priority:

Operator	Description
^	Power function
*	Multiply
/	Divide
+	Add
-	Subtract

Figure 1-60 Equation Standard Operator

Furthermore, the equation editor supports standard brackets () and floating-point numbers and following built in constants and variables

Constant/Variable	Description
FREQ	Frequency
W	Frequency * 2 * PI
PI	3.14159...
I or J	Complex imaginary unit = sqrt(-1)
VAR_A	The value of the VAR_A field in the trace edit dialog
VAR_B	The value of the VAR_B field in the trace edit dialog
VAR_C	The value of the VAR_C field in the trace edit dialog

Figure 1-61 Equation built in constants or variables

Following source variables are available

Source Data	Description
S	Measured S-Parameters
M1	S-Parameter Memory slot 1
M2	S-Parameter Memory slot 2
M3	S-Parameter Memory slot 3
M4	S-Parameter Memory slot 4
CH	Channel voltage select (in Bode mode only)

Figure 1-62 Available source data identifiers

Every source variable consists of 4 parameters, or specifies a channel (in gain/phase mode) which can be accessed by a dot and following the parameter kind as:

Parameter type	Description
S	S-Parameters
T	T-Parameters
Z	Z-Parameters
Y	Y-Parameters
A	ABCD-Parameters
1	Channel 1 (in Bode mode)
2	Channel 2 (in Bode mode)
A	Channel A (in Bode mode)
B	Channel B (in Bode mode)

Figure 1-63 Available source data parameters

The parameter identifier is attached to the parameter type, with no space in between the two:

Parameter identifier	Description
11	X ₁₁ Parameter
12	X ₁₂ Parameter
21	X ₂₁ Parameter
22	X ₂₂ Parameter

Figure 1-64 Available parameter identifiers

For example: S.Z11 is the Z11 parameter of the measured S-Parameters, M1.T21 is the T21 parameter of memory slot 1. In gain phase mode, the only valid parameters are CH.1, CH.2, CH.A and CH.B. When gain phase mode is selected, all other parameters become unavailable, while in VNA mode the CH parameter is disabled and would produce a syntax error.

Furthermore, various functions $f(x)$ can be applied on the parameters above:

Function	Description
REAL()	Real part of complex number
IMAG()	Imaginary part of complex number
ABS()	Absolute value of complex number
ARG()	Phase of complex number in radians
DB10()	$10 \cdot \log_{10}(x)$
DB20()	$20 \cdot \log_{10}(x)$
LOG()	$\log_{10}(x)$ logarithm to the base of 10
LN()	$\ln(x)$ logarithm to the base of e
EXP()	e to the power of x
SQRT()	Square root
SIN()	Sine
COS()	Cosine
TAN()	Tangens
COT()	Cotangens
ASIN()	Arcussine
ACOS()	Arcuscosine
ATAN()	Arcustangens
ACOT()	Arcuscotangens
SINH()	Hyperbolic sine
COSH()	Hyperbolic cosine
TANH()	Hyperbolic tangens
ASINH()	Arcus hyperbolic sine
ACOSH()	Arcus hyperbolic cosine
ATANH()	Arcus hyperbolic tangens
TO_IMAG()	Convert from real to imaginary
TO_Z()	Convert from reflection to impedance
TO_Y()	Convert from reflection to admittance
TO_VSWR()	Convert from reflection to VSWR
CONJ()	Make conjugate complex

Figure 1-65 Available functions



The equation editor will immediately display any syntax errors on pressing <return>. Source variables are only accessible if they exist, otherwise there will be an error upon entry.

Using Equations within Equations

It is possible to use global equations in other global equations or trace equations.

To use the result of a global equation, use the Syntax: *EQ.<name>*

If the name of an equation is for example "area", the syntax is: *EQ.area*

The results may be real or complex values. If the output of a global equation is used within another global equation, the name of the equation is just known to consecutive equations and not to the preceding equations. This will prevent circular use of equation names.

Using tuneable values in equations

Tuneable values are defined by their names. To define a tuneable value, use the syntax: *VAL.<name>*

e.g. if a value name is "voltage" the syntax will be: *VAL.voltage*

Tuneable values can be used in both types of equations: trace equations and global equations.

Using Traces in Equations

It is possible to use a trace as a function within an equation, however, there are limitations:

- *) The trace used cannot be created by an equation
- *) Traces can only be used in global equations.

The syntax is: *TRC.<diagram name>.<trace_name>(<argument>)*

for example: *TRC.diag1.trace2(freq)*

will use the trace with the name trace2 in diagram diag1 and use the current frequency as argument.

The argument can of course be any real value or term.

If a trace is deleted, the equations using the trace will become invalid.

Using Markers in Equations

Markers and their values can also be used in equations with some limitations:

- *) The trace used by the marker cannot be created by an equation
- *) Markers can only be used in global equations.

The syntax is:

MKR.<diagram name>.<marker name>.<type>

type must be either X or Y, while x denotes the x-axis mostly the frequency and y the marker value or the y value

Example: *MKR.diag1.mkr2.X*

will readout the x value (or frequency) of the Marker on diagram diag1 with the name mkr2

MKR.diag1.mkr2.Y will readout the y value of the Marker on diagram diag1 with the name mkr2

1.14 Diagram Operations

All TBVNAs diagrams follow the same concept and are explained in the same chapter. Not every procedure or setup is possible for every diagram. Some are application-dependent.

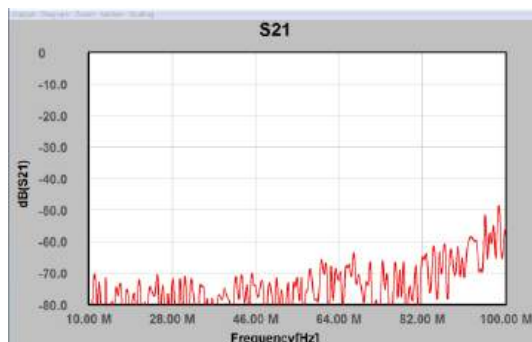

Figure 1-66 Example; rectangular diagram

There are many setup, display, and manipulation options available, which will be described in the corresponding chapters.

1.14.1 Move and glue the diagram to other windows.

The diagram window can be placed anywhere on the screen(s) using conventional Windows manipulation methods such as moving the window title bar. Adjusting the size of the window will automatically scale its contents and traces. To prevent windows from disappearing, some apps may deactivate the close window button.

Each diagram can be “glued” to the associated GUI dialog or to other diagrams. To do so, press the <CTRL> or <STRG> key while dragging a window towards an adjacent window. Each window can be attached to the right or bottom side of an adjacent diagram or GUI panel. Either at the center of the edge or at the corner. If the diagram is close enough, it will snap to the other window upon releasing the left mouse key.

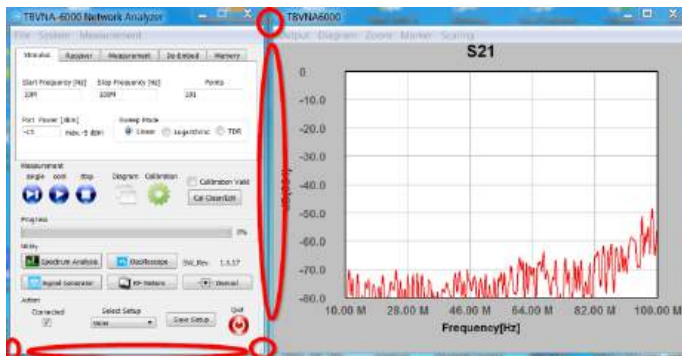

Figure 1-67 Possible “glue points” of a diagram (red marking)

To remove the glue point, press the left mouse key and drag the diagram away from the window it is attached to.

1.14.2 Print, Copy and Save diagrams.

The Output menu bar provides the following operations

- **Print**
This resizes the window to the current set printer page size and prints the diagram to the current printer.
- **Copy to Clipboard**
This will transfer the diagram's bitmap in its current size to the clipboard.
- **Save Image**
This saves the bitmap of the current diagram to disk.

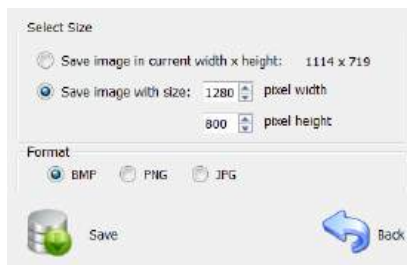

Figure 1-68 “save image” window

- **Close**
Closes the current diagram. The diagram will disappear.

1.14.3 Diagram Properties.

There are several options to open the diagram properties dialog.

- Right click on an empty section of the diagram and select "Edit Diagram properties" to display the context menu

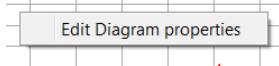

- Following dialog will pop up, when double clicking on an empty section of the diagram and selecting the "Properties" item from the "Diagram" menu.



Figure 1-69 "Y-Axis" diagram properties tab

Use the Y-Axis tab to configure the Y-axis parameters. Depending on the utility, various fields may be disabled. For example, in spectrum analyzer mode, you have to use the analyzer menu to scale the Y-axis. The Y-axis labeling may have two sides: left and right, which share the same grid lines but differ in offset, scaling and measurement unit. If necessary, the right y-axis can be activated. Traces can be assigned to the left or right axis. E.g. gain to the left Y-axis and phase to the right Y-axis.

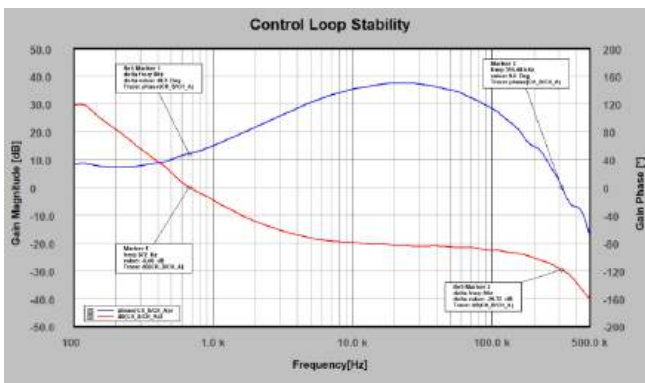

Figure 1-70 Diagram with two independently scaled y-axis

The "Label" field corresponds with the label displayed next to the axis, whereas the "unit" field contains the unit of the displayed traces. The "Short Label" field is utilized elsewhere, such as markers, and should be kept brief in length. The minimum value represents the axis's bottom value, while the maximum represents the top value. Tick the "logarithmic" checkbox to make the y axis logarithmic, and enable auto scale if desired. Select "Dark Background", if you prefer a dark design style.

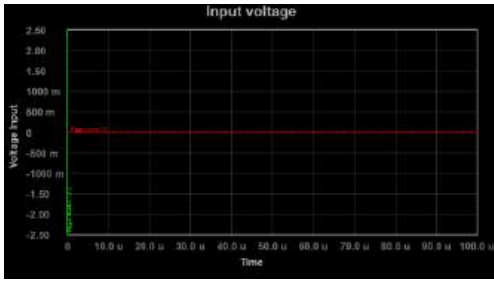

Figure 1-71 Dark style diagram

- The "Setup Axis" button will open a new window that allows you to comfortably scale the y axis. This menu can also be launched by double-clicking on the graph window's Y-axis.



Figure 1-72 Y-Axis setup tab

Use the Y-axis dialog to change the number of vertical gridlines, font size and axis accuracy (number of displayed digits). Moreover, you can setup the axis in relation to the reference level, or by setting minimum and maximum levels.

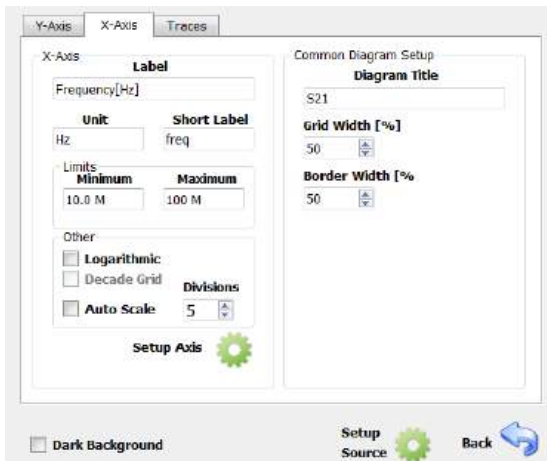

Figure 1-73 X-Axis setup tab

Use the X-axis tab to configure labels and the displayed frequency range. The x-axis can be set to either linear or logarithmic scaling, and Auto Scale can be enabled. Decade Grid will let the logarithmic scale always use 1, 10, 100 divisions. For comfortable scaling, press the Setup Axis button.

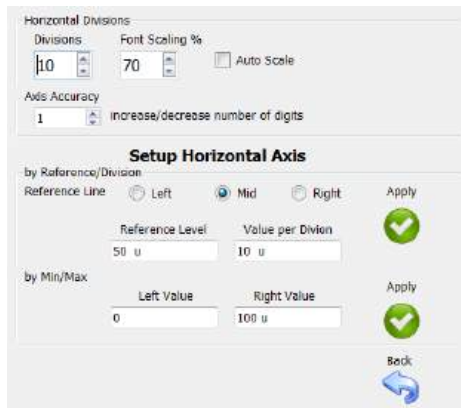

Figure 1-74 Horizontal-Axis setup tab

Double-clicking the X-Axis in the graph will also bring up the Setup Horizontal Axis menu, which provides quick access to scaling options.

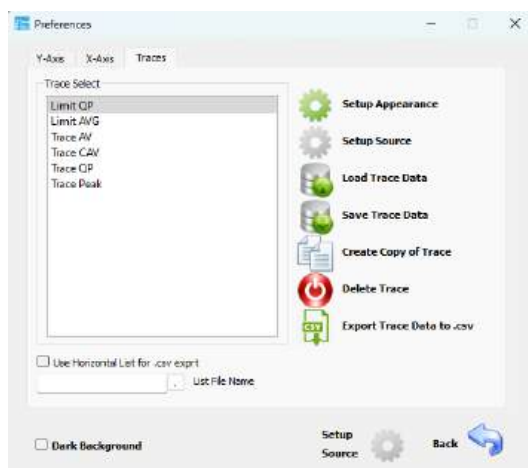

Figure 1-75 Traces setup tab

The Traces Setup tab shows a list of all the traces assigned to the diagram. Pressing the "Setup Appearance" button allows you to fine-tune each trace's settings. "Setup Source" is only enabled if the trace generating application permits to edit the trace-data generation setup. An application specific dialog will appear to configure further trace details.

Traces can be loaded and saved to/from the diagram, but once loaded, the displayed data is static and will not be modified by current or future measurements. Saved/loaded traces are used to document modifications or simply for comparison. A copy can also be made from a selected trace, but it will be a static duplicate and unaffected by measurements. Traces can also be deleted if the application supports it. Certain traces are locked and cannot be deleted. Moreover, trace data can be exported into a .csv file for external processing.

The Checkbox "Use Horizontal List for .csv export" will use an external list of x-axis values (for example frequency values), interpolate the corresponding Y value from the trace for each x-axis value in the list and save this data to the .csv file. This is useful when the internal x-values do not match the intended x-values. The data format is a simple text file with one x-value (frequency point) per text line.



Figure 1-76 Trace appearance setup

The "Trace Appearance" dialog allows you to specify additional settings for the selected trace. You can change the trace name, click on the color wheel to change the trace color or change the line width of the trace.

The interpolation section facilitates to use "Spline" interpolation between data-points.

	<p>Under certain conditions, spline interpolation may cause over-or undershoot of the displayed graph. If you suspect non-physical behavior, switch to "Show Known Points" and compare</p>
---	--

"Show known Points" will display Dots for each "real" measurement point.

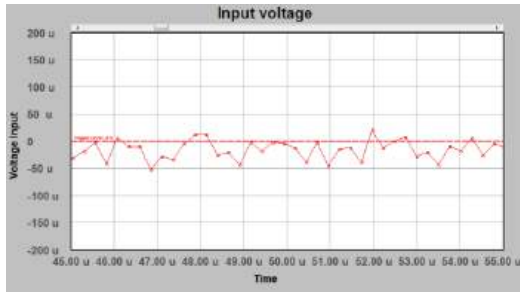
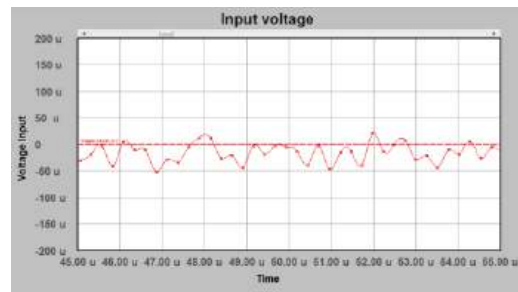

Figure 1-77 Displaying real data points (Show Known Points)



Same data points, spline enabled

The Trace Type section allows you to configure the trace data representation. The "Vertical Bars" setting will display the above data as:

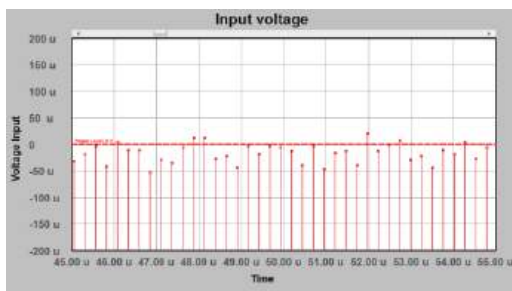

Figure 1-78 Same data points with vertical bars enabled

Another type of data representation is the "parametric" representation, which is only used in polar-plots and smith diagrams and includes complex numbers.

Another useful extension is the application of Persistency. This concept dates back to the analog oscilloscope storage CRT technology. A displayed trace will have some afterglow and become increasingly transparent with each subsequent measurement. The number of traces stored in "Afterglow" can be configured, with the oldest one having the highest transparency. However, "Constant Transparency" can be enabled, displaying all previous sweeps with the same transparency. Additionally, the color of the transparency can be adjusted.

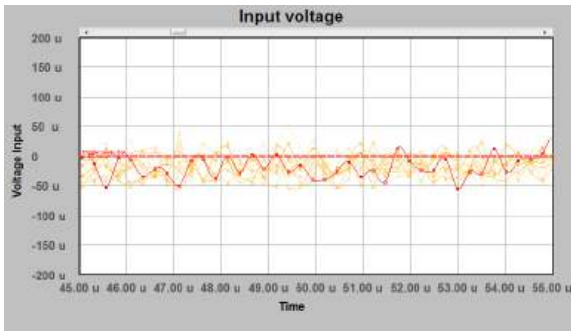

Figure 1-79 Diagram with ten traces, persistency with fading transparency and orange colour

Moreover, the appearance setup dialog allows to save the trace data or to export it into a .csv file.

1.14.4 Quick Diagram Setup

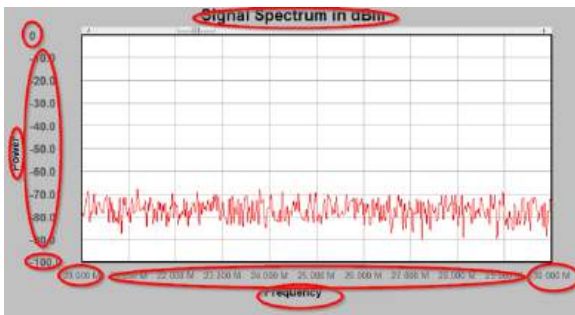

Figure 1-80 Content that can be edited directly

Double-clicking within the areas shown above allows you to enter data directly without having to navigate through the menu bar.

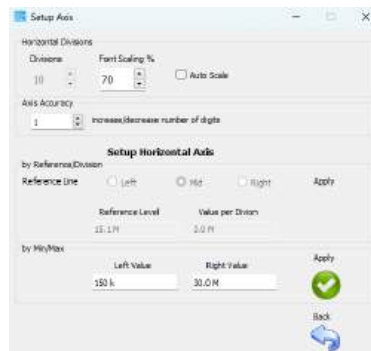

Figure 1-81 Example; dialogs upon double-clicking on diagram content

1.14.5 Trace selection and Trace Context Menu

Any trace can be marked with a single left click. The trace will be highlighted in yellow color.

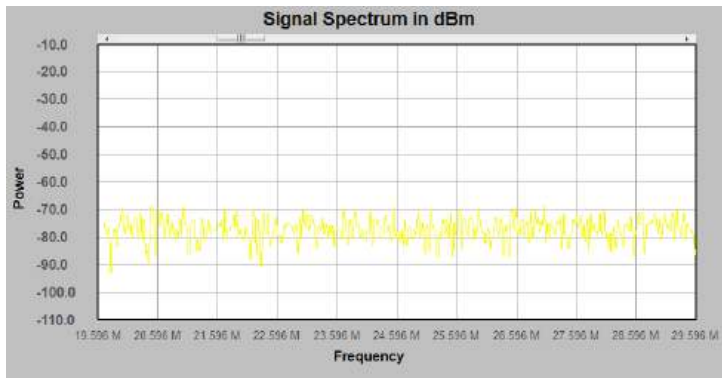

Figure 1-82 Highlighted trace

The following key/mouse combinations work on a highlighted trace:

- **<Delete>**
Will delete the selected trace, if the application allows it.
- **<Ctrl> + C**
Will make a copy of the currently selected trace.
- **Mouse double-click**
Will open the trace appearance setup dialog.

You can also use the menu: Diagram -> Copy Trace to make a copy of the selected trace.

Certain applications, such as the oscilloscope, allow you to offset a trace by dragging. Arrows will appear in trace-color to the right and left side of the diagram, showing the actual "zero" position of the trace.

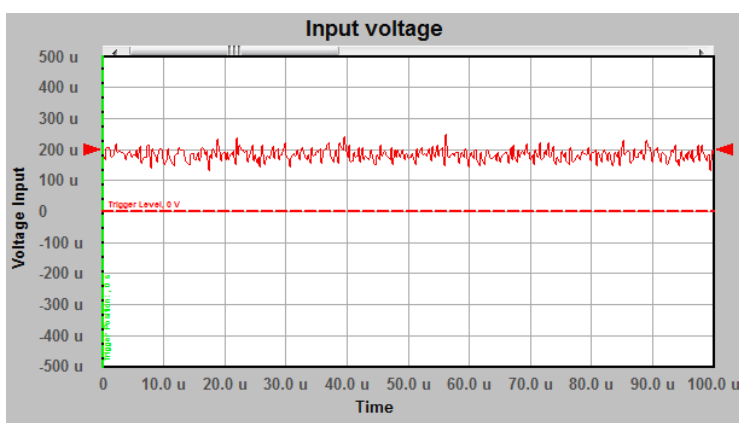

Figure 1-83 Trace with 200µV offset

Use this function to offset multiple traces with the same zero position, improving visibility.

Right clicking a highlighted trace brings up a context menu:

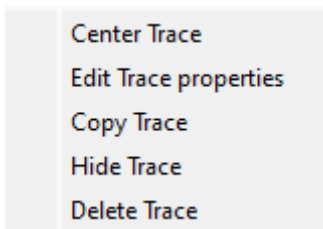

Figure 1-84 Trace context menu

- **Center Trace**
Removes any display offset
- **Edit Trace properties**
Opens the trace appearance dialog
- **Copy Trace**
Creates a copy of the selected trace
- **Hide Trace**
Makes a trace invisible without deleting it. To restore trace visibility, select the "is visible" checkbox in the trace appearance dialog of the Diagram Properties menu.
- **Delete Trace**
Deletes a trace, unless it is locked

1.14.6 Legend

To improve readability when there are multiple traces in a diagram, a legend label displays trace names and their corresponding trace colours. Create a legend for a diagram by:

- Selecting the Diagram menu -> Add Legend
- Or key combination <Ctrl> + L

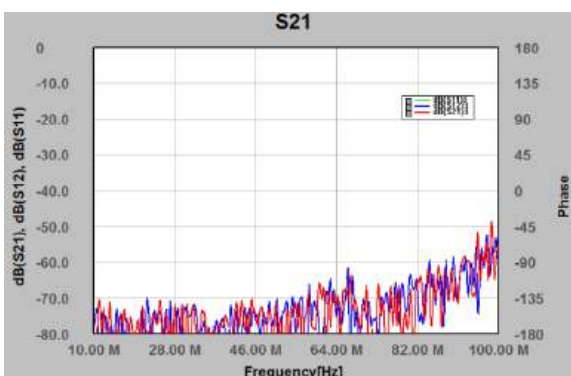
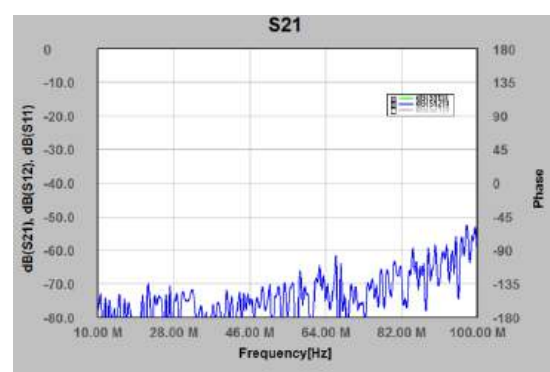

Figure 1-85 Legend label, displayed in the diagram corner



S21 trace set invisible

Trace visibility can be controlled by clicking on the boxes in the legend's trace list. Moreover, this feature helps to identify traces.

1.14.7 Labels

Use labels to add customized text to the diagram. Each label can have up to 3 text lines.

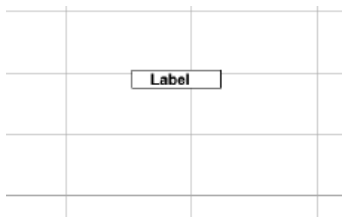
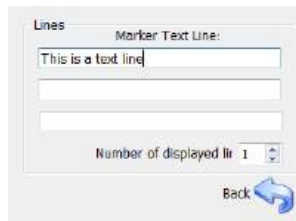

Figure 1-86 Example label



Label editor

The Diagram / Add Label menu brings up a label editor where you can enter up to three lines of text. Existing labels can be moved, deleted, or edited.

- **Move:**
Drag and drop
- **Delete:**
Left click the label to highlight it in red. Press the key or right click the label to access the context menu.
- **Edit:**
Double-Click the label or select the label, open the context menu and select "Marker properties".

1.14.8 Pan

To pan the display, click on an empty area of the diagram and move the mouse while holding down the left mouse key. It is able to pan along the X, Y, or both axes. The pan step width might be either one vertical or horizontal grid section. Please be aware that certain applications may have prevented panning and taken control of the diagram's position. Once a second right y axis is enabled, panning can be done on the left, both, or just the right Y axis.

The diagram area is divided into 3 horizontal sections to select the desired axis. Depending on where the mouse pointer is first clicked for panning, the corresponding axis is selected. The center area selects both axes.

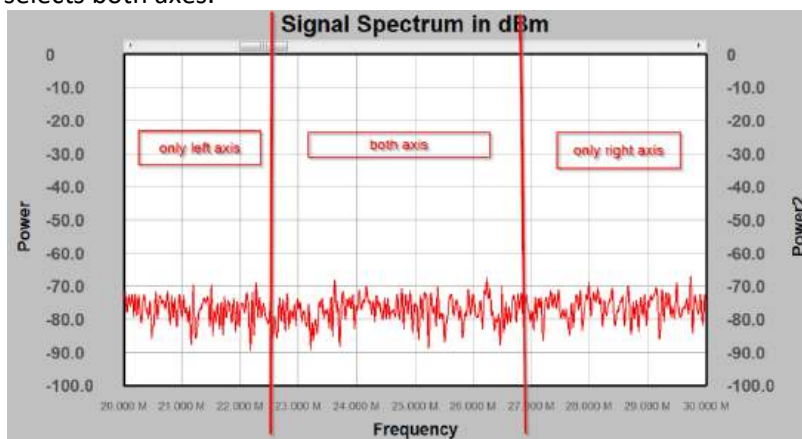

Figure 1-87 Y-Axis selection areas

The panning step grid can be disabled by pressing the modifier keys while panning, allowing for fine panning.

- <CTRL> + Horizontal pan
- <Shift> + Vertical pan

Certain applications disable fine panning.

1.14.9 Zooming

- **Horizontal Zoom**

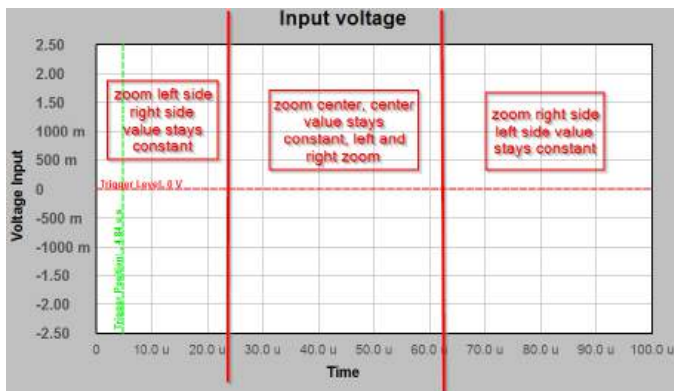

Figure 1-88 Horizontal Zoom selection areas

Horizontal zooming is done by using the mouse wheel without pressing any modifier keys or mouse buttons. Make sure the diagram window is active. The type of horizontal zooming is selected by the position of the mouse pointer. If the mouse pointer is positioned in the left area of the diagram while using the mouse wheel, the diagram's start position will change while the horizontal end position remains steady. Assume the trace is fixed in the above diagram at the right 100 us position, while the left side zooms in or out.

The same thing can be done on the opposite side. If the mouse pointer is near the center of the diagram, the zoom will keep the center value (above, the 50 us position) fixed while zooming the left and right sides in or out.

Please note that zooming can be disabled by some applications.

- **Vertical Zoom**

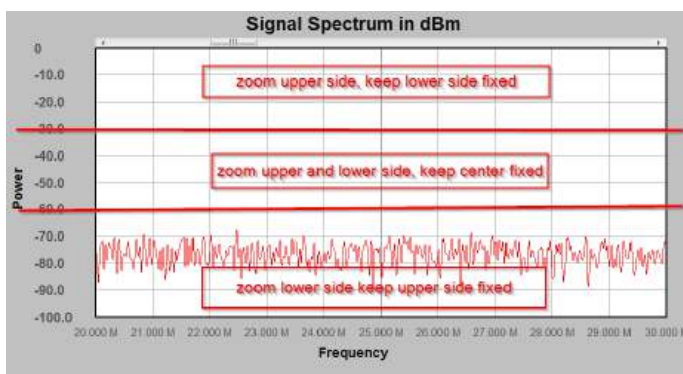

Figure 1-89 Vertical Zoom selection areas

The vertical zooms function similarly to the horizontal zoom. To zoom vertically, use the mouse wheel with the key pressed. Depending on where the mouse pointer is located in the diagram, the upper, lower, or center sections remain fixed while the others zoom. Please take note: The section where the mouse pointer is located will be zoomed. The other side remains constant. For the center section, the center value remains constant. In the case of two Y axes enabled, the above diagram can be further sectioned as follows:

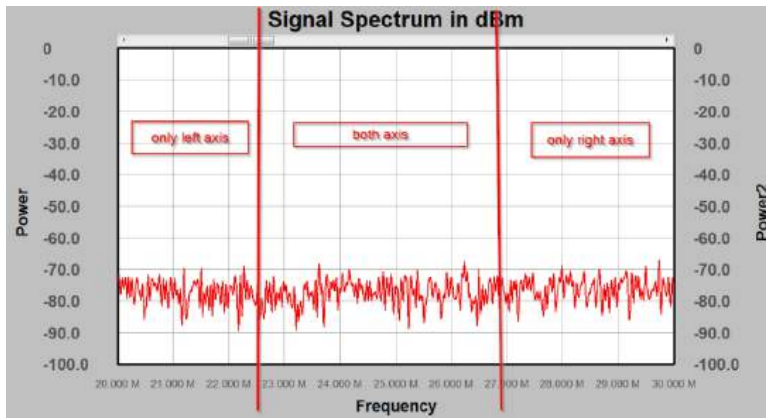

Figure 1-90 Further Zoom selection areas

In total, the diagram is divided into nine sections, with the mouse pointer allowing you to select the Y-axis and side to zoom in on.

1.14.10 Scaling

Scaling is selectable by the diagram menu "Scaling" and relates to one time or continuous auto-zoom, where the diagram's traces determine the X and Y position as well as scaling.

- Scale vertical (left and right); alternatively use the <v> key
Both Y axes (if available) will be zoomed to show all traces in the diagram window. Some margin at the top and bottom will be inserted.
- Scale vertical left; alternatively use the <l> key
Only the left axis will be zoomed to show all traces in the diagram window. Some margin at the top and bottom will be inserted.
- Scale vertical right also use the <r> key
Only the right axis (if available) will be zoomed to show all traces in the diagram window. Some margin at the top and bottom will be inserted.

Enabling Auto scale will always try to display all traces within the window.

However, Auto scale will not be available within all applications.

Horizontal zoom out is useful for re-centering a trace in the horizontal axis and can simply undo huge magnifications and pan. The <h>key also allows for horizontal zoom out.

1.14.11 Markers

Markers are used to highlight certain values on traces or to indicate limits in diagrams. The following markers are available:

- Normal marker
- Delta Normal Marker
- Vertical Line
- Horizontal Line

Normal Markers

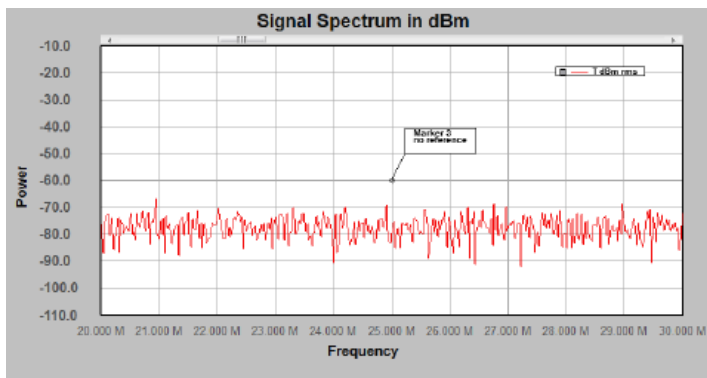

Figure 1-91 Normal Marker without reference

A Normal marker can be added using two methods:

- Menu: Marker-> Add Marker
- <CTRL> + M key

A normal marker consists of two components: The box and the reference line, with a little rectangle at the end.



Figure 1-92 Marker components

Both components can be selected and moved. To pick the reference line component, click onto the little rectangle.

The box can be moved to a suitable location on the diagram, while the little rectangle can be dragged to and along a trace, with the marker always jumping to the trace that is closest to the little rectangle. The reference line connects the tiny rectangle to the marker information box.

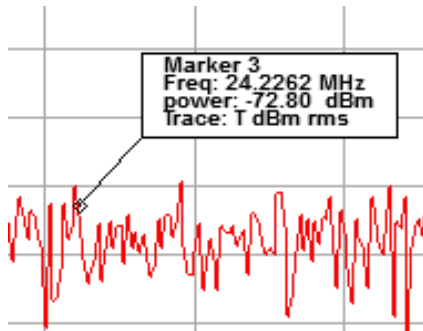
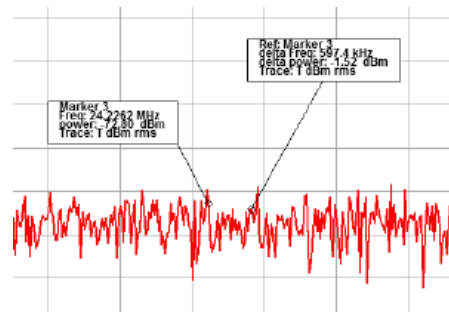

Figure 1-93 Marker locked to a trace



Marker and Delta Marker locked to the same trace

To move the marker to another trace, simply click onto the little rectangle and drag it to the desired trace. Once it gets near, it will snap to the trace.

To create a regular delta marker:

- Menu: Marker-> Add Marker Delta
- <CTRL> + D key

The resulting delta marker will always reference the most recently created normal marker on the same trace.

The delta marker will display both the delta-X and delta-Y value. More options are accessible in the marker properties dialog, which will be detailed later.

To delete a normal marker:

- Select Delete from the context menu
- Press the Key

Markers can also be moved with the keyboard:

Select the little rectangle of the marker with the mouse.

Use <arrow left> or <arrow right>keys to move the marker.

Use <SHIFT> + <arrow left> or <SHIFT> + <arrow right>keys to move the marker in smaller steps

Use <CTRL> + <arrow left> or <CTRL> + <arrow right>keys to move the marker in very small steps

Select a marker and right-click the mouse to access the context menu:

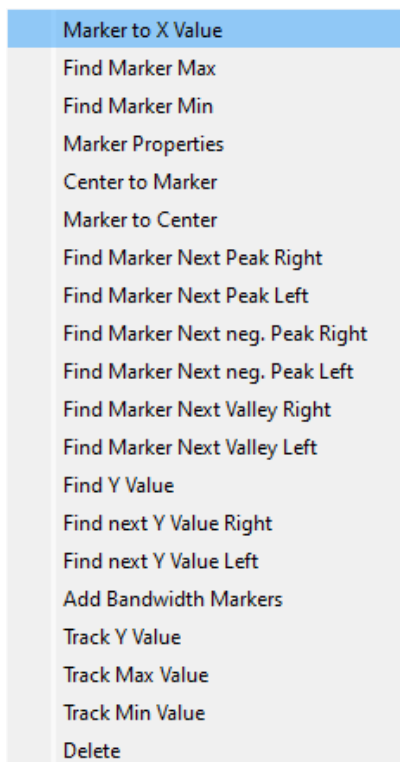

Figure 1-94 Normal Marker, Context Menu

- **Marker to X Value**
Opens a little dialog, showing the marker's current X-value. Change this value to move the marker to the desired position.
- **Find Marker Max**
The marker will move to the maximum Y value of the referenced trace.
- **Find Marker Min**
The marker will move to the minimum Y value of the referenced trace.
- **Marker Properties**
The Marker Properties Dialog will open.
- **Center to Marker**
Centers the x-axis to the current markers' X-position.
- **Marker to Center**
The marker position will move to the horizontal center of the diagram.
- **Find Marker Next Peak Right**
Searches for another peak to the right of the current position.
- **Find Marker Next Peak Left**
Searches for another peak to the left of the current position.
- **Find Marker Next neg. Peak Right**
Searches for another negative peak to the right of the current position.
- **Find Marker Next neg. Peak Left**
Searches for another negative peak to the left of the current position.
- **Find Marker Next Valley Right**

Searches a local minimum between two peaks to the right of the current marker's X-position.

- **Find Marker Next Valley Left**
searches' local minimum between two peaks to the left of the current marker's X-position.
- **Find Y-value**
Opens a dialog box asking for a Y-value. Searches the diagram from left to right for the selected value and, if found, place the marker there.
- **Find next Y value right**
Opens a dialog box asking for a Y-value. Searches the diagram from the current markersX-position to the right for the selected value and,if found, place the marker there.
- **Find next Y value left**
Opens a dialog box asking for a Y-value. Searchesthe diagram from the current markersX-position to the left for the selected value and, if found, place the marker there.
- **Add Bandwidth Marker**
Opens a dialog box, by default set to -3 (for -3dB bandwidth). It is assumed that the current marker is positioned on the peak of a resonance or filter center frequency. Delta markers are added to the right and left side of the current marker, with their Y-value matching the offset specified in the dialog box.
- **Track Y-value**
During continuous measurements, the marker will aim to keep its Y-value at the current level, and the x position will automatically update at each sweep.
- **Track max value**
During continuous measurements, the marker will aim to keep its Y-value at the maximum level and the X-position will automatically update at each sweep.
- **Track min value**
During continuous measurements, the marker will aim to keep its Y-value at the minimum level and the X-position will automatically update at each sweep.
- **Delete**
Deletes the current marker. This option is disabled for particular markers in specific applications, such as the trigger level marker, for example.

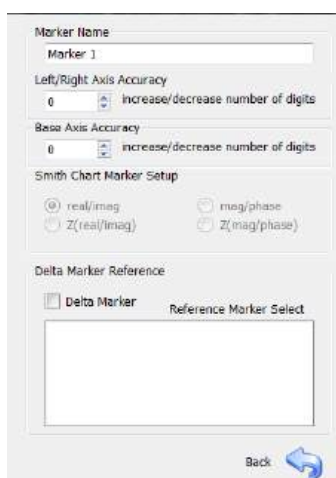

Figure 1-95 Marker Properties dialog

Use the Marker Properties dialog to edit following marker settings:

- Marker Name
- Axis Accuracy (Display more or less decimals)
- In Smith Charts: Unit of the reflection coefficient (disabled)
- Turn a marker to a delta marker and select the reference marker from a list.

Vertical Line:

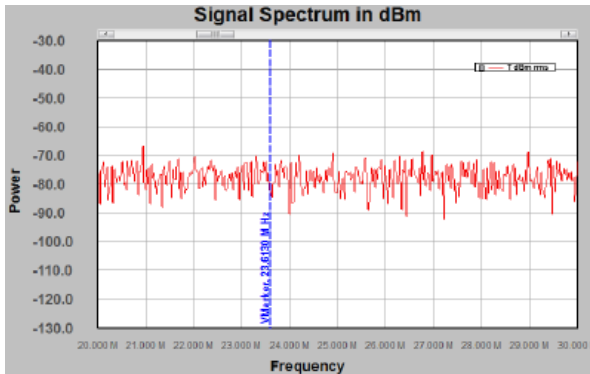

Figure 1-96 Vertical line

To make a vertical line, select the menu:

Marker -> Add Marker VLine

The vertical line can be dragged to any desired X-value, and the current X-value will be displayed along the line. The context menu will allow you to open the properties dialog or delete the marker.

Marker -> Add Marker VLine Delta

adds a Delta Marker vertical line. The most recent Vline Marker is used for reference. Using the properties editor, other VLine Markers can be selected as reference.

Markers can also be moved with the keyboard:

Select the little rectangle with the mouse.

Use <arrow left> or <arrow right>keys to move the marker.

Use <SHIFT> + <arrow left> or <SHIFT> + <arrow right>keys to move the marker in smaller steps

Use <CTRL> + <arrow left> or <CTRL> + <arrow right>keys to move the marker in very small steps

Horizontal Line:

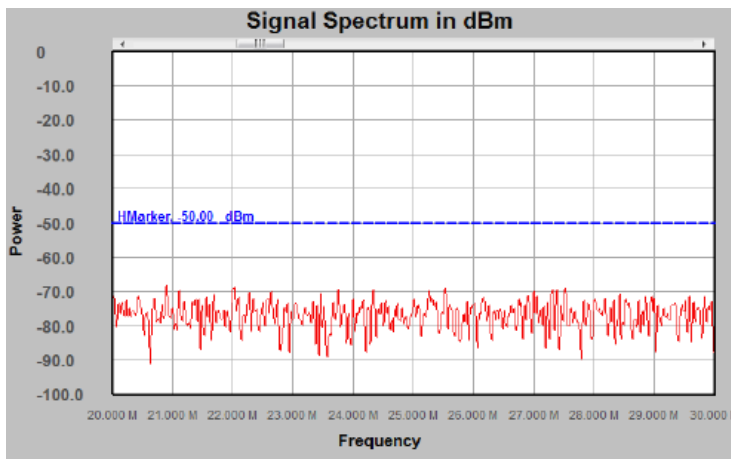

Figure 1-97 Horizontal line

To make a horizontal line, select the menu:

Marker -> Add Marker HLine Left

or

Marker -> Add Marker HLine Right (referenced to the right axis if available)

The horizontal line can be dragged to any desired Y-value, and the current Y-value will be displayed along the line. The context menu will allow you to open the properties dialog or delete the marker.

Marker -> Add Marker HLine Delta left

Marker -> Add Marker HLine Delta right (referenced to the right axis if available)

adds a Delta Marker horizontal line. The most recent Hline Marker is used for reference. Using the properties editor, other HLine Markers can be selected as reference.

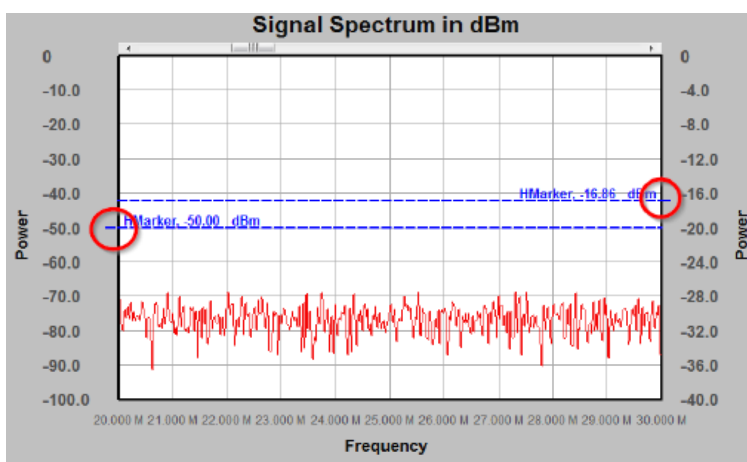

Figure 1-98 Horizontal line on diagram with two Y-axes

With two y-axes enabled, extending the HLine Marker to the left or right side will indicate which axis the marker is referring to.

The Marker menu includes the following additional functions:

- Delete Marker (deletes selected marker)
- Marker find max (finds maximum of currently selected normal marker)
- Marker find min (finds minimum of currently selected normal marker)
- Marker to center
Centers the x-axis to the current marker's X-position

Markers can also be moved with the keyboard:

Select the little rectangle of the marker with the mouse.

Use <arrow left> or <arrow right>keys to move the marker.

Use <SHIFT> + <arrow up> or <SHIFT> + <arrow down>keys to move the marker in small steps

Use <CTRL> + <arrow up> or <CTRL> + <arrow down>keys to move the marker in very small steps.

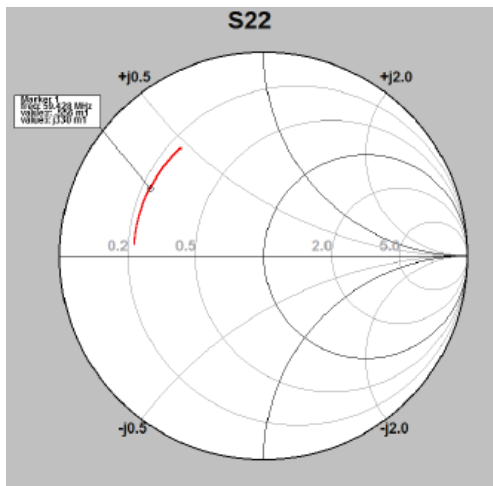

Figure 1-99 Smith Diagram with marker

Smith and polar diagrams can only use normal markers and delta markers. Double-clicking on the marker will open the marker setup dialog.

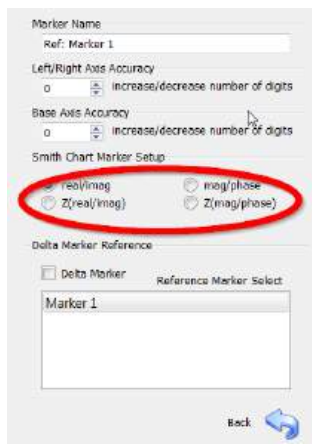

Figure 1-100 Marker Setup Dialog

For Polar- and Smith-Plots the marker text can be configured to display either:

- Real and Imaginary part
- Magnitude and Phase Display
- Z (eq. impedance) in real and imaginary value
- Z(eq. impedance) in magnitude and phase value

1.15 The Main Dialog Menu

1.15.1 File / Load / Save Calibration

This menu items are used to load a new calibration set or save the current calibration.

1.15.2 File / Load / Save Setup

The TBVNA-6000 setup enables convenient preservation of a prior system state. Once all diagrams, traces and calibration are defined, the save setup command will save all the data to disk. You can load the setup files for later measurements with the same setup . Since it is possible to define an arbitrary number of setups, switching to a different workbench is a matter of a click. Furthermore, there is a quick setup select box in the lower right corner of the main dialog.

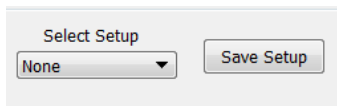

All setups saved in the "Setups" folder are listed in the setup selection box. A single drop down select will switch to different setups.

1.15.3 File / Save S-Parameter

The Save S-parameter menu item will save the current measured s-parameter in the popular Touchstone .s2p file format.

1.15.4 File / Select Home Path

The select home path command will allow to change to a different home path than the <USERS>\<CURRENT_USER>\TekBox\TBVNA-6000 folder.

The default folder uses following sub-directory structure to save data:

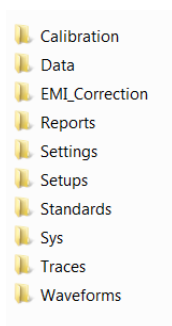

Figure 1-101 TBVNA-6000 user directories.

It is recommended to keep this folder structure, since various system functions use it. Once a new home path has been chosen, the setup is changed in the subdirectory:

<Program Data>\TekBox\TBVNA-6000

1.15.5 System / System Test

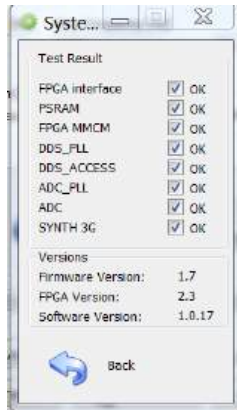

Figure 1-102 TBVNA-6000 system test.

The system test checks system health and displays software and hardware revisions.

1.15.6 System / Unlock Calibration

System Update and Calibration is locked by a password. In order to enable these menus, it is necessary to unlock these functions first. After installation no password is set, so by unlocking the system functions it is sufficient just to press enter when the password request dialog appears. However it is highly recommended to define a password to protect the device from an unintended calibration attempt or software update.

1.15.7 System / Change password.

The default password is pressing <ENTER>. It is recommended to configure your own password.

 Select a safe password to protect the TBVNA-6000!

It is also recommended to write-protect the file

<Program Data>\TekBox\TBVNA-6000\app_config.cfg

and grant ownership only to the system administrator.

1.15.8 System / Service

This menu can only be accessed after entering the password. Following dialog will appear:



Figure 1-103 System Service dialog.

You can save or load the factory HW calibration data (Full Calibration). It is recommended to store a backup of the calibration data in a safe place. Furthermore, it is possible to restore only partial calibration data from the backup. This menu also enables TBVNA-6000 microcontroller and FPGA Flash firmware updates.



Do Not unplug the TBVNA-6000 during a Firmware update or Calibration loading process! After a FW update, wait 10 seconds and perform a power cycle!

1.15.9 Measurement / Edit Memory Slots

The memory slots are used to store S-Parameter as a reference used in Trace measurement functions. S-Parameter files can be either loaded from disk or copied for the current measured S-parameters.

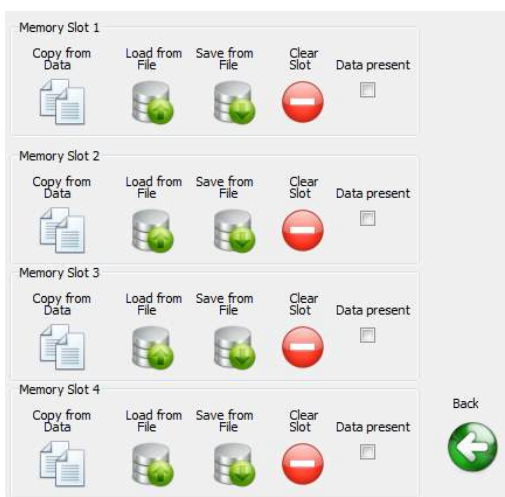

Figure 1-104 Memory slot dialog.

Every memory slot can be edited and slot data can be even saved to disk. (Touchstone format). The "Clear Slot" button will delete all memory slot data.

The same operations can be performed in the main dialog "De-embed" Tab.



Figure 1-105 Memory slot Tab.

1.15.10 Measurement / De-Embedding (full)

This command allows the definition of an electrical network for each port. During measurement this "virtual" network will be extracted from the measurement. It is sufficient to have the S-parameter description of the parasitic network in Touchstone-Format to perform this task.



Figure 1-106 De-Embedding dialog.

Whereas the interactive simple de-embedding possibilities in the main dialog can only simulate a lossy transmission line, the full de-embedding allows the removal of any complex two port network.

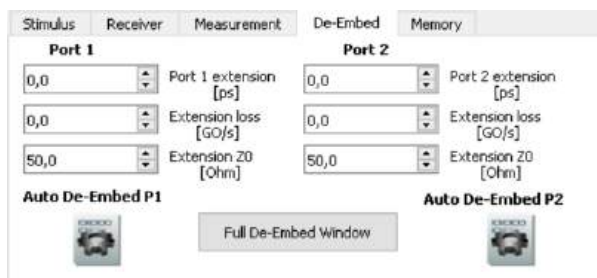

Figure 1-107 Simple De-Embedding.

The simple de-embedding is very useful, when coaxial lines are used to connect the DUT with the analyzer and the reference planes are at the connection of these coaxial lines and the plane of calibration. As the coaxial lines will introduce extra phase shift and loss to the calibration it is useful to remove these lines from measurement. This can be done during measurement. Short circuit the end of these lines and adjust the parameters in figure 4.7 until you can read a clear short circuit in the smith-diagram of S11 and S22. With this method you can shift the reference plane with little errors to the end of the test lines. Simple de-embedding can be done manually or automatically.

Following example will demonstrate the automatic de-embedding process.

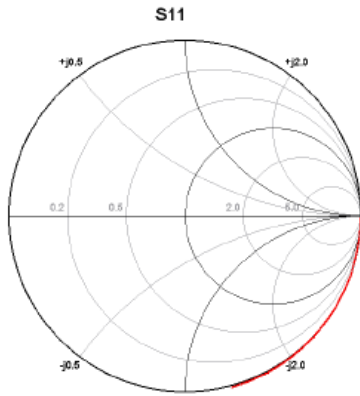

Figure 1-108 S11 after calibration.

The Smith diagram shows an example measurement of an open port after calibration and some unknown port extension. Goal of the process is to "compress" the S11 graph into one point, namely into $S_{11} = 1.0$, which represents a perfect open. To do so press the "Auto De-Embed P1" button, an additional smith diagram and a new dialog appear.

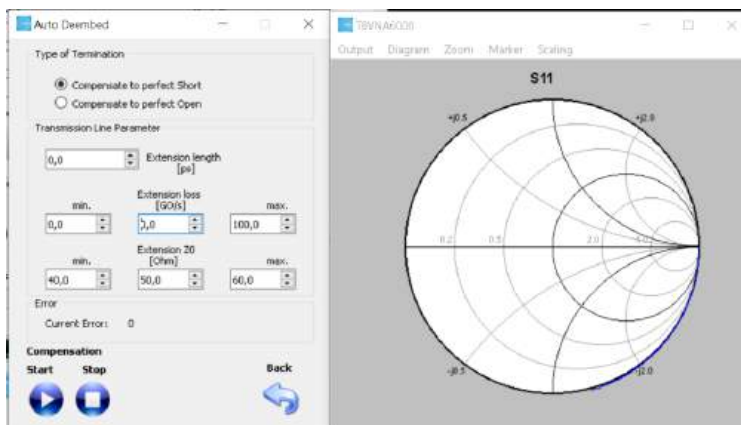

Figure 1-109 Auto De-embed Windows

Next, select "Compensate to perfect open", Enter -100 to min. Extension Loss and press "Start".

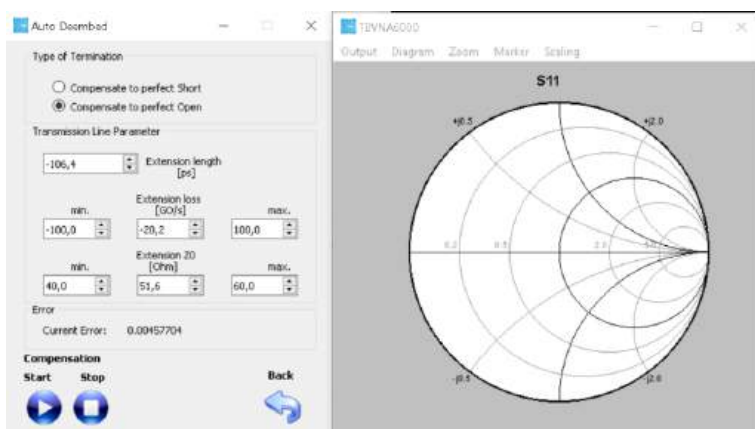

Figure 1-110 Auto De-embed Windows after a few iterations

Wait and watch as the S11 graph compresses into S11 = 1. If you see no improvement in the Current Error, press Stop and Back. The calculated values will be transferred to the De-Embed Tab fields.

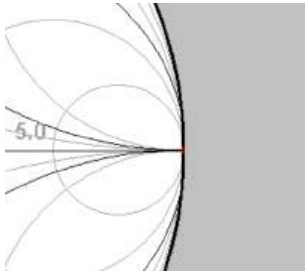

Figure 1-111 S11 diagram with De-Embedded Open Measurement.

1.15.11 Measurement / Show Limits



Figure 1-112 Limits Test Window.

The limits test window will show all the limits defined in the trace dialogs, and perform the defined tests on the current measurements. A Pass/Fail evaluation for every test is shown in each line. The system will then perform an evaluation of each test to generate the total output result. This feature is helpful in production, where a set of complex measurement conditions must be evaluated.

1.15.12 Limits definition in the trace edit dialog

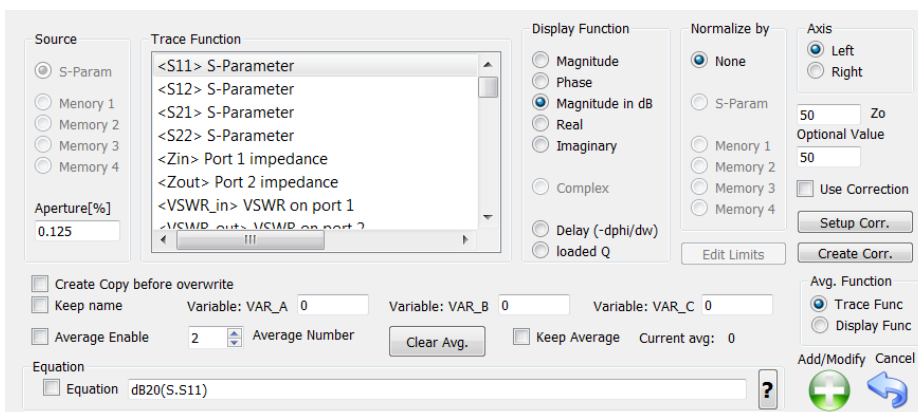



Figure 1-113 Trace Edit Dialog

Once a trace has been defined, several test limits can be defined. This can be done by opening the trace edit dialog and pressing the "Edit Limits" dialog.

 Limit editing is only available for existing trace-functions. After pressing the Add button, leave the dialog and edit (modify) the trace function.

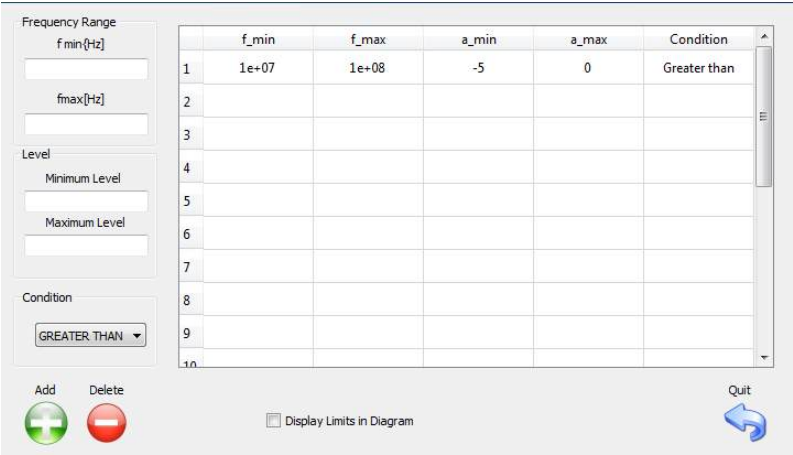

Figure 1-114 Trace Limits Dialog

The trace limits dialog permits the creation of up to 20 limit definitions consisting of a valid frequency range, a limit condition and min/max values.

Following conditions can be defined :

- Greater than minimum value
- Less that maximum value
- Within min/max value
- Outside the min/max value band

The "Display Limits in diagram" check box will allow to display the limits in a diagram.

 Limits can only be displayed in rectangular diagrams.

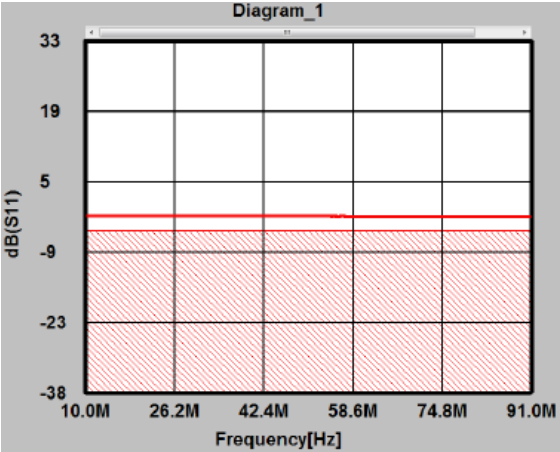

Figure 1-115 Diagram with lower limit

1.16 Utilities

1.16.1 Spectrum Analyzer Utility

The spectrum analyzer utility contains several useful sub functions, which can perform useful tasks to support the electronic design process:

- Standard Spectrum Analyzer
- Phase Noise Analyzer
- Logarithmic Spectrum Analyzer

1.16.1.1 Spectrum Analyzer

The Spectrum analyzer feature displays a single trace window. Note that auto-scaling will be enabled.

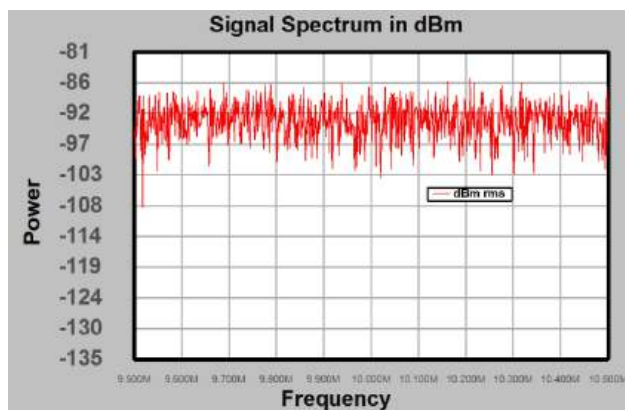

Figure 1-116 Spectrum Analyzer data window.

A spectrum analyzer control window appears next to the spectrum analyzer.

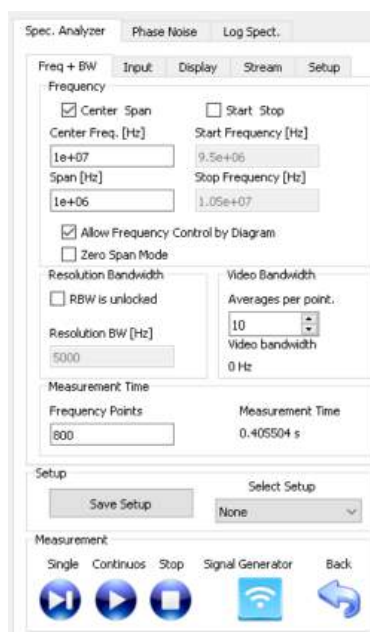

Figure 1-117 Spectrum Analyzer control window.

Frequency and bandwidth setup

The spectrum analyzer has two frequency range control options:

- Center and Span
- Start- and Stop Frequency.

Upon selecting the desired frequency range, resolution bandwidth, measurement time per point and frequency points are set automatically. It is possible to unlock the resolution bandwidth. Averages per point corresponds to the video bandwidth often used in analog spectrum analyzer, it will average several magnitude values. Further it is possible to define an external gainfileto compensate for external amplifiers connected to theRF input. This enables extending the dynamic range and performingultra-low noise measurements. The resolution bandwidth can be adjusted between 0.1 Hz - 3 MHz, with no granularity.

Zero Span mode allows to measure the signal amplitude over time

Input Setup

The input setup allows to select single or dual channel mode. In dual channel mode the instrumentprovides two separate analyzers simultaneously sampling Port 1 and Port 2 or Port A and Port B.In order to use Port A and B the BODE option must be installed. The input range can be configured independently for each channel.

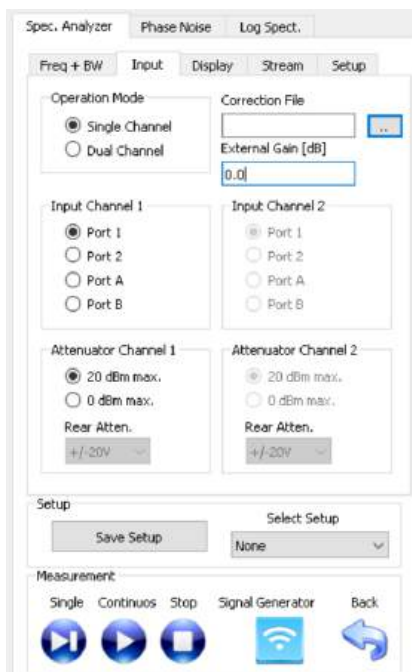

Figure 1-118 Spectrum Analyzer control window, input tab.



Do not exceed the +20 dBm input level limitation of Port 1 or Port 2! Excessive input power will damage the instrument.

Display Setup

In the display tab, output scaling and display functions can be configured:

In single channel mode:

- RMS = root mean square or "real" power
- Maximum value (maximum peak)
- Minimum value (minimum peak)
- Average.

In dual channel mode:

- RMS channel 1
- RMS channel 2
- Correlation between channel 1 and 2

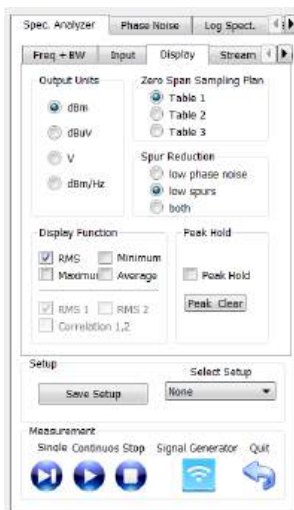

Figure 1-119 Spectrum Analyzer control window, display tab.

The "Peak Hold" feature memorizes peak values on each sweep. The "Peak Clear" button resets the trace.

Since the analyzer uses a 125 MHz ADC clock, the unambiguous frequency range has a maximum of 60 MHz. In "low phase noise" mode, the instrument uses a constant clock frequency. With clock dithering, the unambiguous frequency range can be extended to 6 GHz for (multiple)single narrowband carrier signals and resolution bandwidth settings ≤ 200 kHz. This mode requires twice the measurement time compared to "low phase noise" mode. When measuring broadband signals like OFDM or CDMA modulated carriers exceeding 10 MHz or more, the spectrum might show spurious signals. This mode is called "low spurs" mode. In low spurs mode the carrier SSB noise is worse than in low phase noise mode. However the combined "low spurs + low noise" mode will compensate for this at the cost of a longer measurement time (3 x compared to low noise mode).



The TBVNA-6000 Spectrum Analyzer utility does not implement a standard spectrum analyzer with Preselector and sideband suppression and may suffer from spurious signal distortion and inaccuracy.

The spectrum analyzer can be calibrated by using a calibrated signal source. The "Calibration" button is password protected.

Streaming

The spectrum analyzer can stream or record live IQ data up to a rate of 2.7 MT/s. To enable streaming, the frequency span needs to be set to zero. Please note that the maximum streaming rate is limited by the quality of the USB connection.

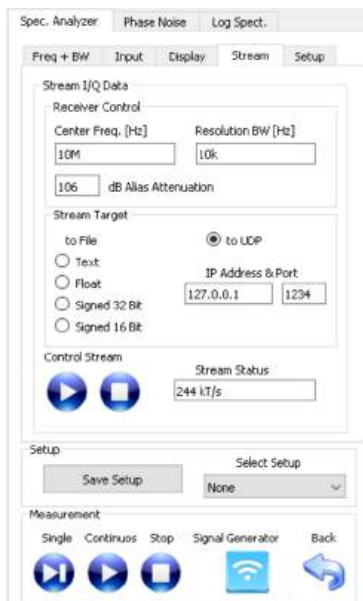

Figure 1-120 Spectrum Analyzer control window, stream tab.

Adjust the resolution bandwidth to alter the transfer rate. Higher resolution bandwidth settings will result in a higher transfer rate. The bandwidth is limited by the maximum transfer rate. It is possible to reduce the "alias signal attenuation" to reduce the transfer rate at the expense of sideband suppression. The maximum down-sampling factor is limited by the internal RBW filters. Reducing sampling rate will fold higher frequency spectrum into the lower sideband. The attenuation of these "folded" spectrum is given by the "dB max Alias" field. When the nominal value of 106 dB is reduced, higher data rate dividers are allowed by a given resolution bandwidth. Be aware that the signal SNR will be reduced by this value. If a SNR of 50 dB is required, do not reduce this value below 50 dB.



Note that a change in the "dB max Alias" field will also affect the displayed spectrum. Be sure to set it back to its original value after streaming.

Streaming can be set to file or an Ethernet UDP sink, as used by GNU radio.

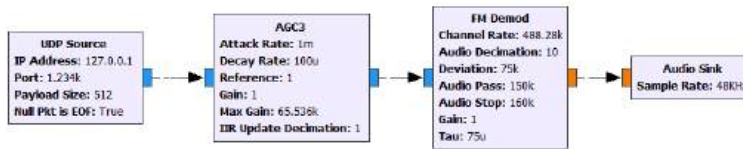

Figure 1-121 GNU-radio example of a simple FM radio receiver

The picture above shows a simple FM radio receiver using the UDP source element. Payload size is set to 512 bytes. Data is sent as float values alternating I and Q values.

If selecting "to File", the data will be written to a text file, each line alternating I and Q float values. Please note that writing to a file can easily overflow and will depend on your computers write file speed capabilities.



Select different Sampling Plan tables in the Display section of the analyzer, if the chosen center frequency comes too close to multiples of 125 MHz.

Setup

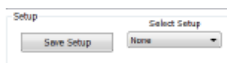

The Setup feature of the spectrum analyzer allows to load / save diagram and configuration setups.

Measurement group



The measurement group allows single and continuous measurements. Furthermore, the built in signal generator can be activated by the "Signal Generator" button. It can be used during spectrum analyzer measurements. However, settings cannot be altered during measurements. When pressing the "Quit" button, the instrument returns to the VNA main menu.

Setup Tab



Figure 1-122 Setup Section of the spectrum analyzer

Use this menu to calibrate the signal generator or spectrum analyzer. Calibration will be explained in detail later. This menu is also used to configure the startup behavior. Selecting "Last", the Analyzer will remember the last settings and reload it on startup. "Custom" allows to automatically load any pre-selected setup.

1.16.1.2 Phase Noise Analyzer

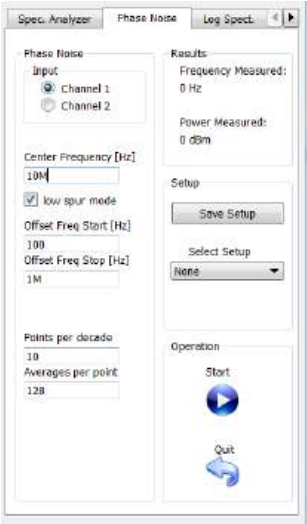

Figure 1-123 Phase Noise Analyzer control window.

The phase noise analyzer measures the single sideband phase noise of a non-modulated signal carrier in the frequency range of 40 Hz to 5990 MHz. (SSB noise).

Select the corresponding input channel and choose the carrier frequency (within +/- 50 kHz). Choose low spur mode when measuring at frequencies > 60 MHz.

The offset frequency range with reference to the carrier can be in the range of 10 Hz - 10 MHz. Select the number of measurement points per offset frequency decade. The number of averages are used to smooth the noise signal. Increase the value to get a smoother result.

Once a carrier has been fed to one of the input ports the phase noise measurement can start.

The instrument measures the accurate level and frequency of the carrier. These values are displayed in the "Results" box of the window. If no carrier is found, an error message will appear.

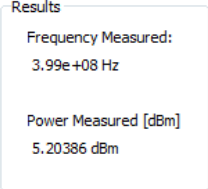

Figure 1-124 Result of the measurement of the internal signal generator; frequency set to 399 MHz

Upon detecting a carrier, the phase noise diagram appears in the left upper corner of the screen.

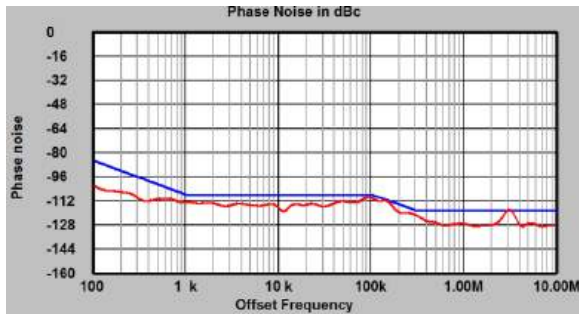

Figure 1-125 399 MHz internal carrier phase noise measurement.

The blue limit line shows the lower measurement limit. Whenever the measured signal comes within 3 dB range of the lower limit. The measured phase noise could be lower than the system's limit, and cannot accurately be measured. The result is presented in dBc (from measured carrier level) in a 1 Hz bandwidth.

The Setup button allows saving of measurements and settings.

1.16.1.3 Logarithmic spectrum analyzer

The logarithmic low frequency spectrum analyzer is used to measure broadband signals in the range of 1 Hz to 60 MHz. In this mode the resolution bandwidth is set as a fraction of the measurement frequency and frequency step distance to create a logarithmic equidistant frequency sweep. The signal power is measured in dBuV.

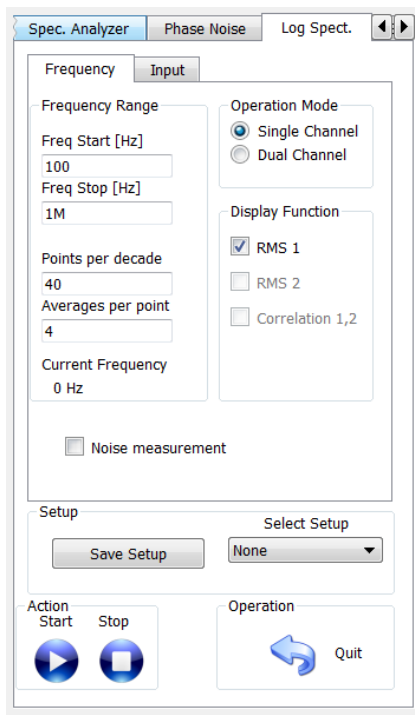

Figure 1-126 Logarithmic Spectrum Analyzer control window, Frequency section

Settings cover start- and stop-frequency, the measurement points per decade and the number of averaged measurements per point. Two channels can be measured in parallel. This enables the display functions RMS, 2 (RMS value channel 2) and the correlation between Channel 1 and 2. The correlation feature reduces noise, when measuring the same signal with two receiver chains. The correlated signal strength follows the equation:

$$a_{corr} = \sqrt{\frac{1}{n} \sum_{i=0}^n a_i b_i}$$

where a_i and b_i are the input channel signals, n = number of samples. If $a_i = b_i$ this equation collapses to the standard RMS (root mean square) formula.



Figure 1-127 Logarithmic Spectrum Analyzer control window, Input section.

The Input tab of the analyzer allows the input selection and the corresponding gain /attenuation. The external gain setting offsets gain / attenuation of external amplifiers or attenuators, assuming a flat transfer function. Setups can be saved or loaded.

⚠ Do not exceed the +20 dBm input level limit on either input! Excessive input power can damage the instrument.

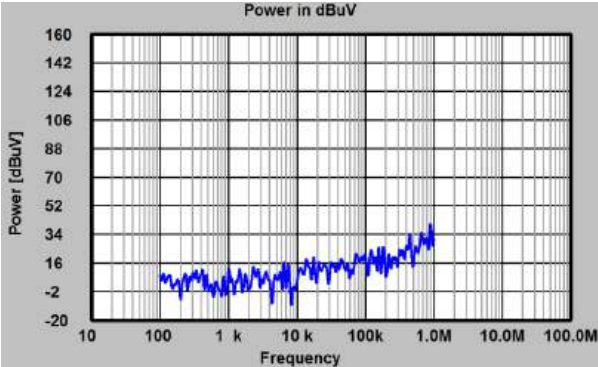

Figure 1-128 Logarithmic Spectrum Analyzer measurement window.

The noise analyzer can be activated by ticking the "Noise measurement" checkbox. The output shows the equivalent noise voltage spectral density in nV/SQRT(Hz). The measurement bandwidth is 1 Hz. It is recommended to increase the number of averages per point to get a clear result. Figure 5.13 shows an open port noise measurement with 500 averages. The noise analysis will open a separate window. An external low noise amplifier of at least 40 dB gain is recommended.

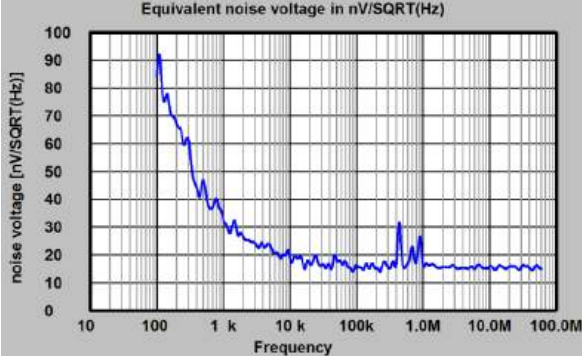

Figure 1-129 Noise level measurement

1.16.2 Oscilloscope Utility

The oscilloscope provides a DC-coupled two channel 125 MSMP/s digital storage oscilloscope with many features.

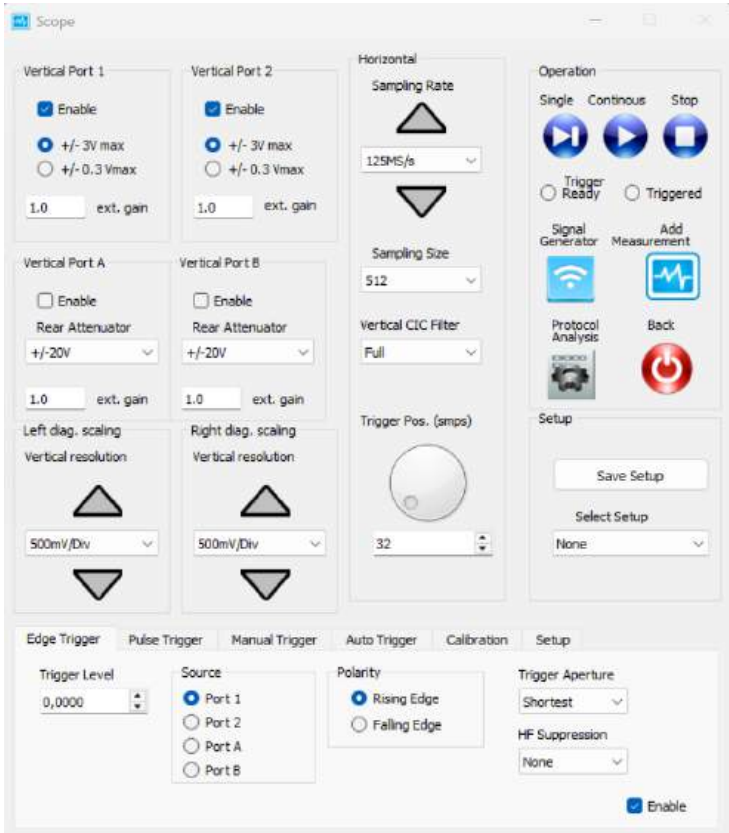

Figure 1-130 Oscilloscope control window

All ports can be individually enabled or disabled by ticking the "Enable" checkbox. Note that Port A & B are only available with the BODE option. Enabling Channel A or B will limit the maximum input of Channel 1 & 2 to +/- 0.3 V.

Port 1 or 2 input range can be set to +/- 3.0V or +/- 0.3V. The lower input range offers better noise performance.

Port A and B can be set to: +/- 20V, +/- 5V and +/- 0.5V

Use the up/down arrows to adjust the vertical resolution of the diagram in units of V/Division. The range is 100 μ V / Div to 1 V / Div. The diagram has a right and left vertical axis. Port 1 & A are coupled to the left vertical axis and Port 2 & B to the right axis.



Do not exceed the +/- 3V input level limit on either input of Port 1 or 2 or +/-20 V on channel A & B! Excessive input power can damage the instrument.

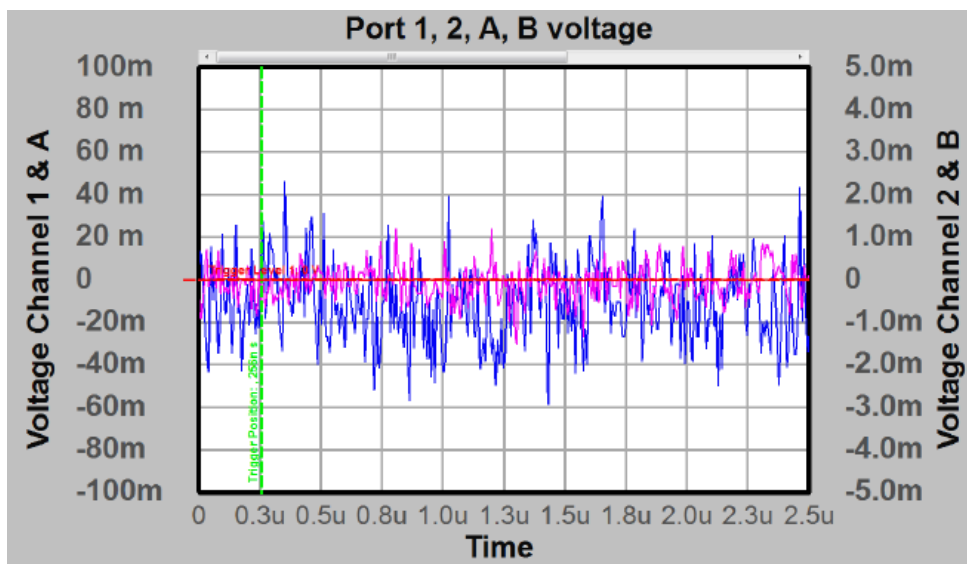

Figure 1-131 oscilloscope measurement window.

Figure 1.129 shows the oscilloscope graph with different resolution of each axis. Note that the blue trace corresponds to the right Y-axis and the red trace to the left Y-axis. The resolution can also be changed with the mouse wheel. Each channel implements an external gain selector to adjust for an optional external amplifier or impedance converter.

The horizontal control allows to change the Sampling rate from 15 S/s to 4 GS/s. However, sampling rates of greater than 125 MS/s are $\sin(x)/x$ interpolated. This interpolation allows correct signal interpretation up to 60 MHz.

The number of samples can be adjusted from 2 to 8192. Furthermore, a vertical CIC (cascaded integrated comb filter) improves noise at low sampling rates.

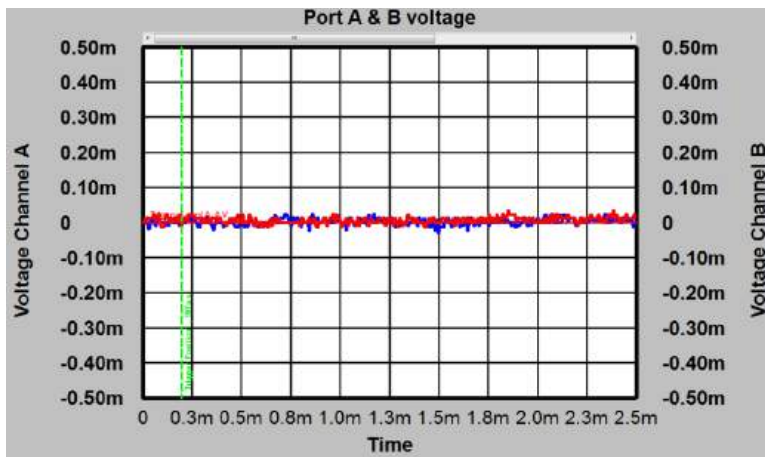

Figure 1-132 oscilloscope measurement with 122 kS/s and 54 kHz bandwidth.

The picture above shows the noise voltage at 122 kS/s sampling rate and 54 kHz bandwidth. It is less than +/- 25uV peak to peak.

Triggering

The "Trigger Position" wheel is used to adjust trigger timing. The trigger point is shown in the oscilloscope diagram as vertical green line and can be adjusted from 0 to 1024 samples. This feature is used to view events before the trigger event.

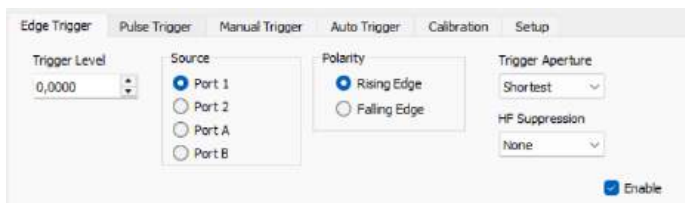

Figure 1-133 Edge trigger tab

The edge trigger will trigger oscilloscope sampling, if the input signal on the selected channel will raise above or fall below a certain trigger level. Adjust the trigger level using the "Trigger level" - spin box or by dragging the red horizontal trigger line in the diagram.

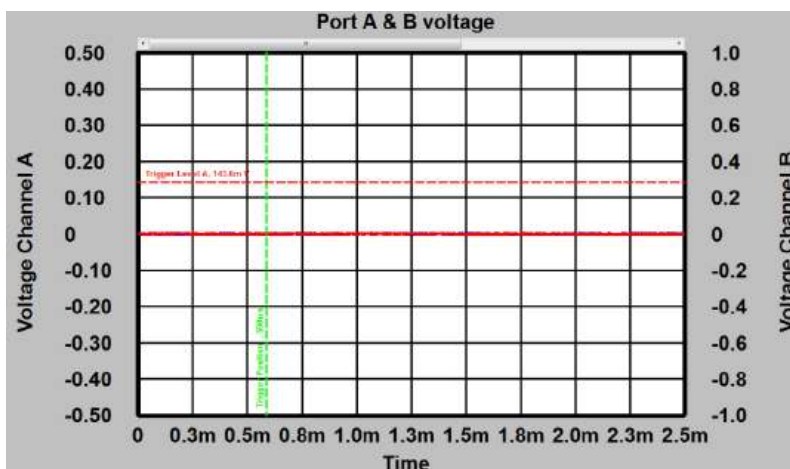

Figure 1-134 oscilloscope data window trigger level of 143.6 mV

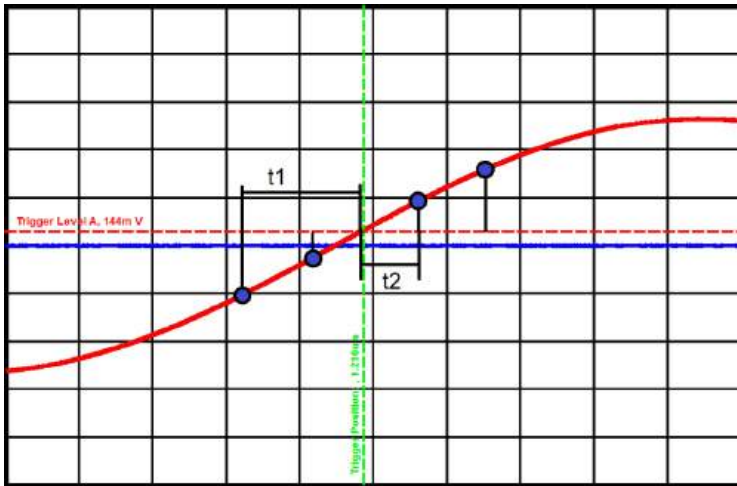

Figure 1-135 Trigger aperture time

The trigger aperture defines the time window in which the edge detection takes place. Figure 1-133 shows two different aperture windows.

Assume that the signal is noisy, and the trigger is set to falling edge detection. There is a high possibility that the trigger event may occur within the time window $2 \times t_2$. As the signal is close to the trigger level it might cross the trigger line multiple times within the trigger time window. This is shown in figure 1-134 below:

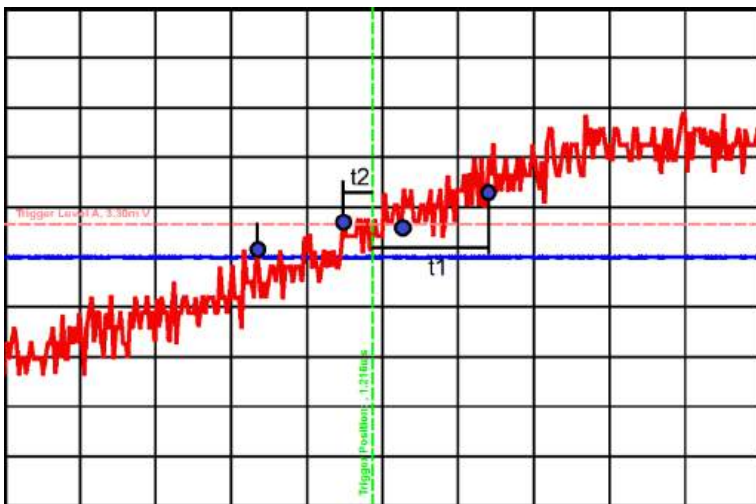

Figure 1-136 Trigger aperture time with noisy signal

Despite a raising level, the falling edge will be triggered with the $2 \times t_2$ trigger aperture time. With a trigger aperture time of t_1 , there would be no false falling edge trigger event. However, widening the trigger aperture window causes increased jitter. Activate HF suppression, which creates a logical "AND" on multiple aperture windows. Assuming that the falling edge event must be true for both trigger aperture windows (t_1 & t_2), the trigger accuracy remains. One drawback of this method is that the trigger could miss trigger events due to HF noise.



Note that Trigger Aperture and HF Suppression settings are also valid for the pulse trigger modes.

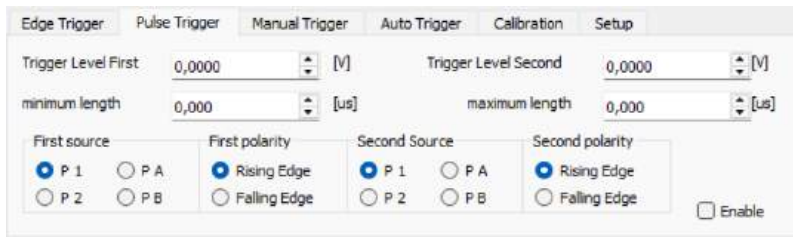

Figure 1-137 Pulse trigger tab

The pulse trigger allows triggering on pulse width events within or across channels. It is enabled by ticking the "Enable" check-box.

Adjust a minimum and maximum pulse width for triggering. Pulse triggering requires two events. A start event and a stop event, with the time in between fulfilling the pulse length setting.

Any of the four Ports can be configured as source for pulse triggering. In case of assigning Port 1 as trigger source, CH1 must be selected as source for the first trigger event and as source for the second trigger event. For a minimum pulse length of t_1 , a maximum pulse length of t_2 , rising edge as first polarity and falling edge as second polarity, the system will trigger on all positive pulses with a length between t_1 and t_2 on Port A.

It is also possible to use two different ports as combined trigger source. Trigger levels for Source 1 & 2 can be set independently.

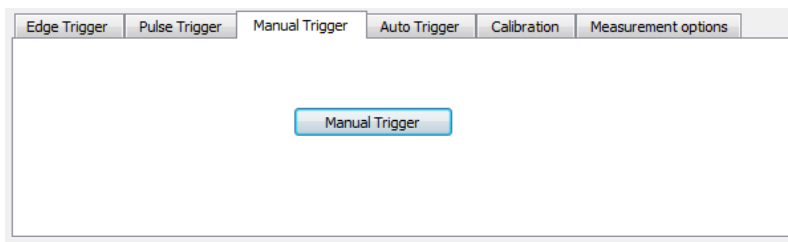

Figure 1-138 Manual trigger tab

Manual trigger is useful, if the trigger level has been changed while the oscilloscope is waiting for triggering. In order to have the trigger level changed, the oscilloscope needs to leave the "wait on event" state. This can be done by pressing the "Manual Trigger" button.

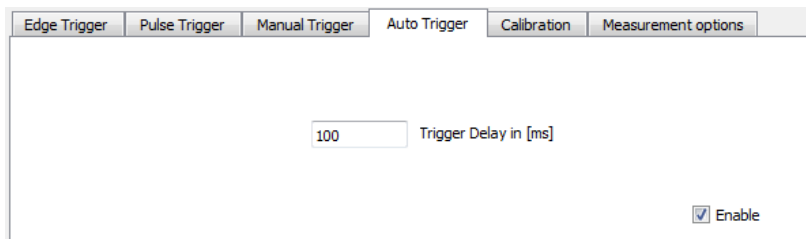

Figure 1-139 Auto trigger tab

The auto-trigger mode can be enabled by ticking the "Enable" checkbox. The oscilloscope will then start a manual trigger if no trigger event occurs within the selectable time period.

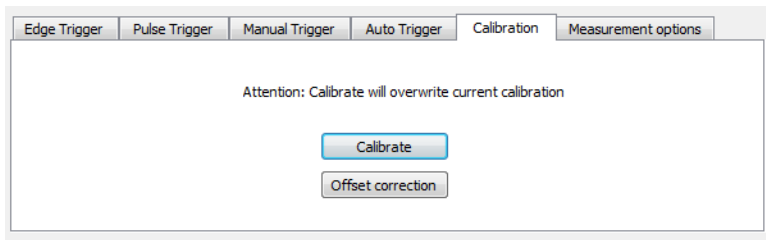

Figure 1-140 Calibration tab

The Calibrate command is password protected. After unlocking calibration the procedure will ask to apply different DC voltages to Port 1 & 2 and Port A & B to calibrate the oscilloscope. A precision DC source is required. Tekbox will soon offer an affordable low cost / low voltage calibrator to perform an auto-calibration.

The "Offset correction" button will compensate any DC offsets in the amplifier chain. Leave all inputs open or terminate it with 50 Ohms to perform the offset correction. Offset correction is recommended, when measuring low voltage signals in the μV range.

Measurements

Upon pressing the "Add Measurement" button, a measurement selection dialog will appear:

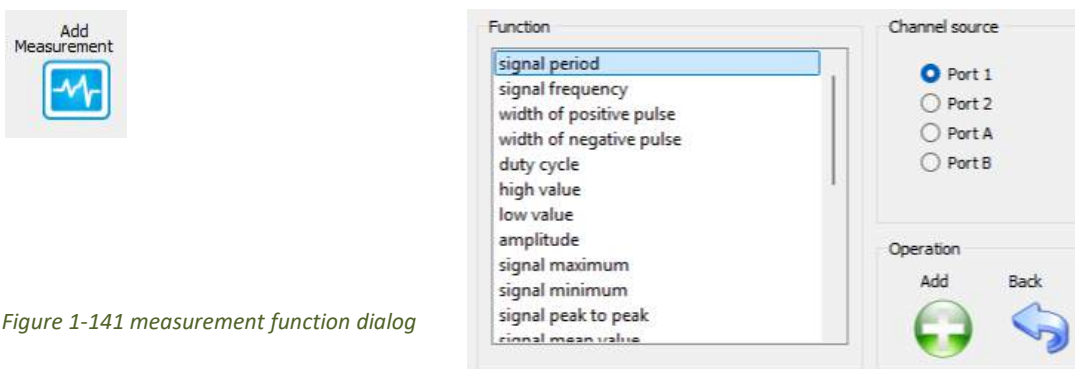

Figure 1-141 measurement function dialog

Following measurement functions are implemented:

Function	Description
Signal period	Period time of a repetitive signal in seconds
Signal frequency	Frequency of a repetitive signal in Hertz
Width of positive pulse	Length of a positive pulse in seconds
Width of negative pulse	Length of a negative pulse in seconds
Duty cycle	Duty cycle in %
High value	Top value of a rectangular/digital signal without overshoot
Low value	Bottom value of a rectangular/digital signal without undershoot
Amplitude	Zero to average peak value
Signal maximum	Positive peak value
Signal minimum	Minimum peak value
Signal peak to peak	Peak to Peak value
Signal mean value	Mean value of captured data
Signal RMS value	Root mean square value of captured data, effective value
Signal standard deviation	Standard deviation from mean value

Auto trigger amplitude	Calculates the peak to peak amplitude with auto threshold level selection.
Rise time	Signal 10% - 90% rise time in seconds
Fall time	Signal 10% - 90% fall time in seconds
Overshoot positive	Amount of positive overshoot in rectangular/digital signal
Overshoot negative	Amount of negative overshoot in rectangular/digital signal
Positive delay A to B	Rising edge delay from channel A to B in seconds
Negative delay A to B	Falling edge delay from channel A to B in seconds
Phase A to B	Phase lag between channel A to channel B in degrees
Jitter rms	RMS Jitter in seconds
Jitter peak	Peak jitter in seconds

Figure 1-142 Oscilloscope measurement functions

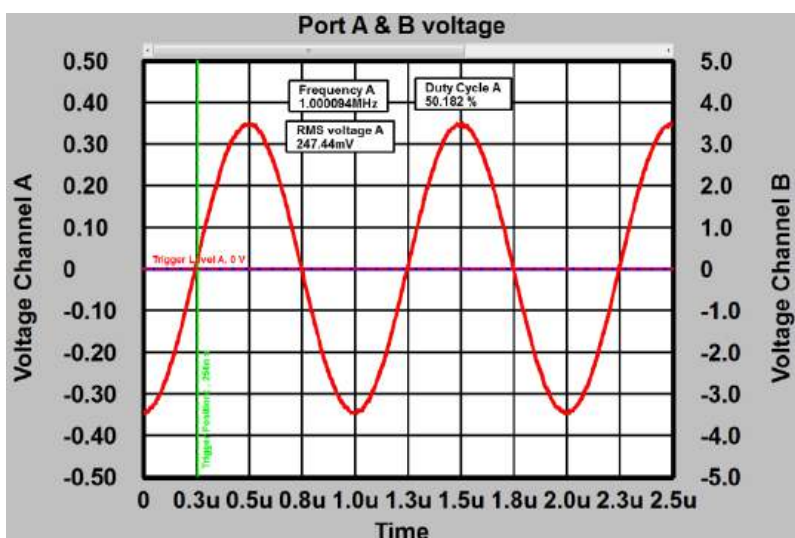

Figure 1-143 screenshot with multiple measurements

Measurement values will update upon re-triggering the oscilloscope. Measurement results are treated similarly as markers. Right click and select Delete from the context menu or select the measurement and press the delete key.

Protocol analyzer

The oscilloscope contains a simple protocol analyzer for frequent digital communication protocols.

- I2C protocol.
- RS232 protocol.
- SPI protocol.

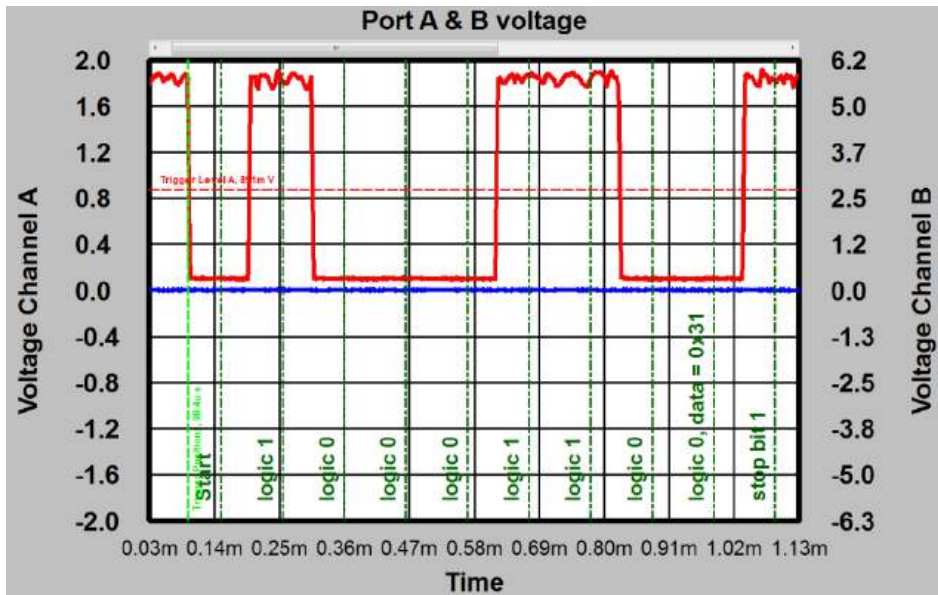

Figure 1-144 screenshot with RS232 protocol analysis

The protocol analyzer can be invoked by pressing the "Protocol Analysis" button.



Figure 1-145 Protocol analyzer button

RS232 analysis

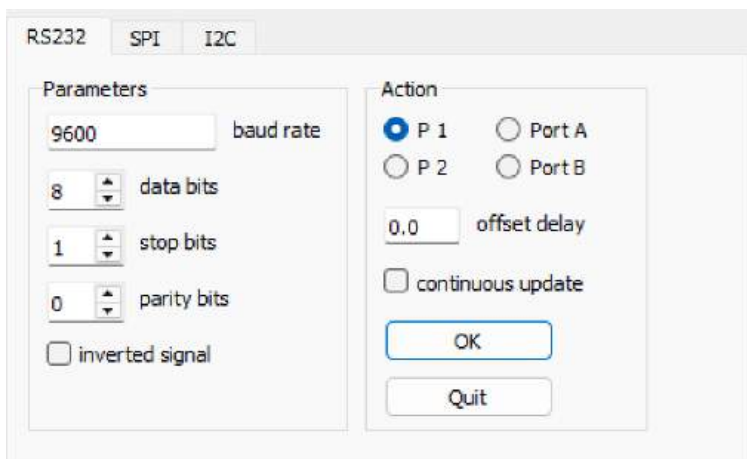

Figure 1-146 RS232 protocol analysis tab

The protocol analyzer supports 1- 64 bits data bits, 1-2 stop bits and 0-1 parity bits. The signal polarity can be inverted and an offset delay allows protocol analysis after a certain dead time.

Each bit is detected and evaluated. After all data bits are detected, the output data is shown in the diagram.

Press "OK" to start analysis. Tick the "hide single bits" checkbox, if only full bytes / words need to be displayed.

SPI analysis

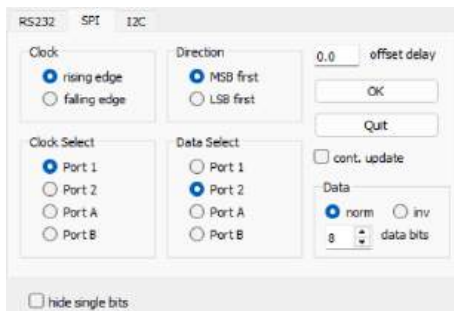

Figure 1-147 SPI protocol analysis tab

The implemented SPI-analysis uses only two wires. The "clock select" group-box assigns the clock source to an input port. Select, whether the rising- or falling- edge is used for data sampling. The data can be processed with normal or inverted polarity. The data word size can be in the range between 1 and 64 bits. The "Direction" group-box allows to select whether most or least significant bit is first. An "offset delay" allows protocol analysis after a certain dead time.

Press "OK" to start analysis.

I2C analysis

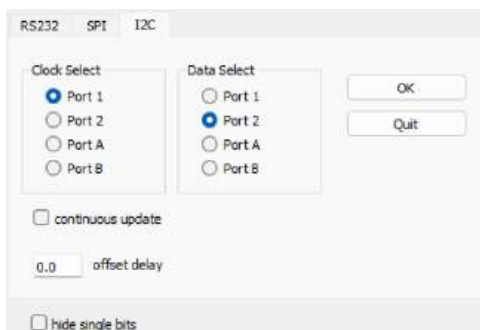

Figure 1-148 I2C protocol analysis tab

The I2C protocol analysis tab assigns the clock input channel and an offset delay parameter allows protocol analysis after a certain dead time.

Press "OK" to start analysis.

Signal generator



Figure 1-149 Signal generator button

After pressing the button, the signal generator window appears. The signal generator can be used as a signal source during oscilloscope measurements. The generator is described in detail in the signal generator utility chapter.

1.16.3 RF Meters Utility

1.16.3.1 Broadband Voltmeter

The broadband voltmeter measures the RMS signal power in a very broad frequency bandwidth with a -3 dB bandwidth of approximately DC to 700 MHz.



Figure 1-150 Broadband voltmeter control window

Select input port and input voltage range. The input attenuators of Port 1 and Port 2 can be configured to provide a +/- 3.0V or +/- 0.3V range. The high impedance input voltage ranges are only available with BODE option.



Do not exceed the maximum input level limits on any Port! Excessive input power will damage the instrument.

Changing the sampling frequency several times during a single measurement will eliminate any potential blind frequency spots. Choose between 1 to 16 sampling frequencies. The update time will increase proportionally with the number of sampling frequencies.

The Average-Time can be adjusted from 1 ms to 4 s. The voltmeter update rate depends on the number of sampling frequencies and the averaging time. Increase averaging time to increase accuracy and reduce noise.

The measured result can be presented in units of Volt, Watt, dB μ V, dBV, dBm and dBW. Set the unit to Volt, dBV or dB μ V only, when measuring signals on Port A or Port B.

The output is displayed as:

- RMS = root mean square, effective value
- Peak value
- Time average value

It is highly recommended to perform an Offset correction before performing measurements. Press

Correct Offset

the "Correct Offset" button:



During offset correction, terminate the configured input with a 50 Ω load or to leave the inputs open.

1.16.3.2 THD meter

The THD (Total Harmonic Distortion) meter is used to measure the harmonic power of a carrier signal or the distortion of a connected 2-port in the frequency range from 40 Hz to 6 GHz.

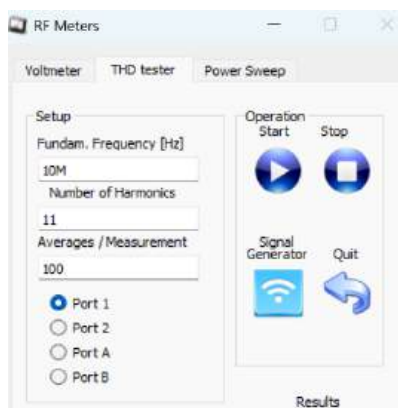

Figure 1-151 THD meter control window

Enter the fundamental frequency of the carrier as basic parameter for a THD measurement. Define the number of harmonics to be used for the THD calculation. Increase averaging to measure with higher accuracy at lower harmonic levels and select the desired input port. Ensure that the maximum harmonic frequency is lower than the 6 GHz maximum input bandwidth.

If the quality of the internal signal generator is not sufficient for the application, use an external low harmonic source. Ensure that the source frequency is stable within 2% of the carrier frequency during measurements.

Click the "Signal Generator" button to open the internal signal generator:



The combination of internal signal generator and THD meter can now be used to measure any two port

After starting the measurement the instrument will determine the carrier power and frequency. The result will be shown in the "Result" test box. The measurement will also open a new diagram and present all harmonic and fundamental signal powers in dBm.

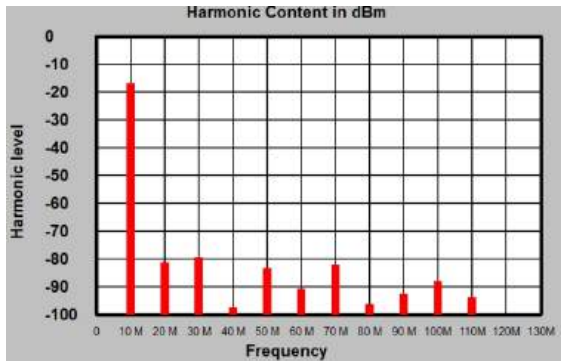

Figure 1-152 THD meter harmonics diagram

The text output shows a list of the measured harmonic values in dBc and calculated THD metrics.

```
f0 = 1e+07 Hz
P = -18.4449 dBm
2xf, P = -64.5494 dBc
3xf, P = -63.2448 dBc
4xf, P = -80.0309 dBc
5xf, P = -66.9793 dBc
6xf, P = -73.375 dBc
7xf, P = -66.4954 dBc
8xf, P = -74.8193 dBc
9xf, P = -75.5169 dBc
10xf, P = -68.9661 dBc
11xf, P = -79.4007 dBc
12xf, P = -78.8912 dBc
THD% = 0.000151732 %, THDdb = -58.1892 dB
THDAudio% = 0.12318 %
```

Figure 1-153 Example THD measurement result.

It is recommended to perform a non-distorted or through measurement to verify the system performance and signal source quality before measuring a Device Under Test. The signal generator's harmonic performance degrades at frequencies below 100 kHz because of the nonlinear behavior of the instrument's solid state switches. These switches cause approximately -40 dBc for the first harmonic and -60 dBc for the second harmonic.

The THD value in percent is calculated as the sum of the harmonic powers in relation to the fundamental power.

$$THD_{\%} = \frac{P_2 + P_3 + P_4 + P_5 + \dots}{P_1}$$

with P1 the fundamental power and P1 - Pn the harmonic power values. The THD value in dB is:

$$THD_{dB} = 10 \cdot \log \left(\frac{P_2 + P_3 + P_4 + P_5 + \dots}{P_1} \right)$$

For audio measurements, THD audio is defined as:

$$THD_{audio} = \frac{\sqrt{V_2^2 + V_3^2 + V_4^2 + V_5^2 + \dots}}{V_1}$$

the effective harmonic voltage relative to the fundamental voltage.

1.16.3.3 Power sweep

Power sweeping is used to measure the linearity of a two port device at a certain constant frequency, but over swept input power. A power sweep diagram displays output power versus input power.

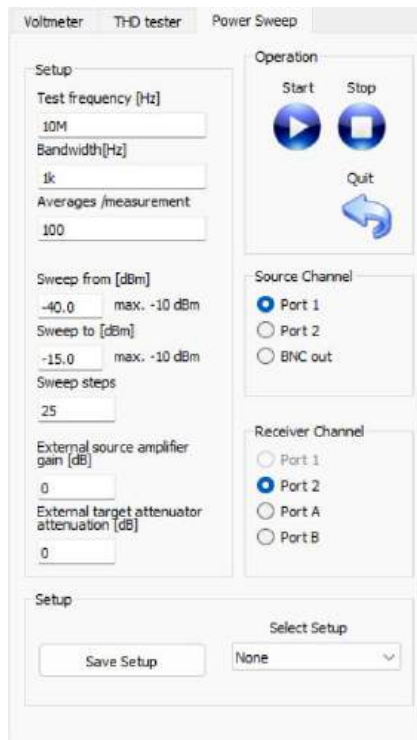

Figure 1-154 Power sweep window

The test frequency can be selected anywhere between 10 Hz and 6 GHz. The resolution bandwidth determines noise floor and measurement speed. A small bandwidth allows accurate measurements at low input power. Averaging reduces fluctuations and noise.

The power sweep at Port1 and Port 2 can cover the range from -80 dBm to -7 dBm (+24 dBm max. for the BNC output). The number of steps determine the resolution of the power sweep.

Avoid overdriving the measurement input. External attenuators may be necessary and can be compensated for.

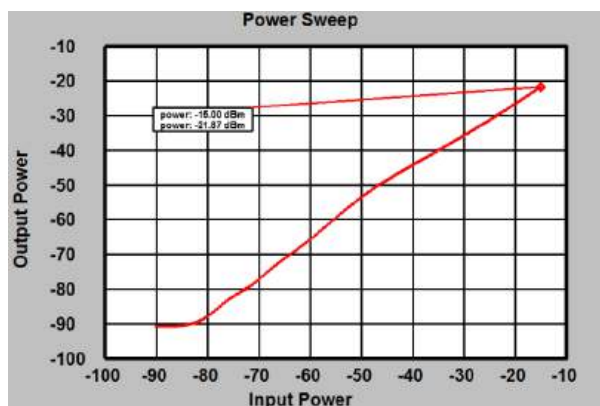

Figure 1-155 Power sweep data window displaying output power over input power in dBm

1.16.4 Demodulator Utility



Figure 1-156 Demodulator Utility

The Demodulator is able to receive small and medium bandwidth signals, demodulate it and transfer it to the PC sound system. Available demodulation schemes are AM, FM and SSB. Adjust the resolution bandwidth to alter the transfer rate. Higher resolution bandwidth settings result in a higher transfer rate. To avoid exceeding maximum transfer rate due to excessive bandwidth, it is possible to reduce the "alias signal attenuation" to get a lower transfer rate at the expense of sideband suppression. When down-sampling takes place in the receiver, the maximum down-sampling factor is limited by the internal RBW filters, to avoid folding higher frequency components into the lower sideband. The attenuation of folded spectral components is entered in the "Aliasing Attenuation" field.

The Demodulator tabs allow to select the desired modulation and displays typical measured modulation parameters.

1.16.5 Signal Generator Utility

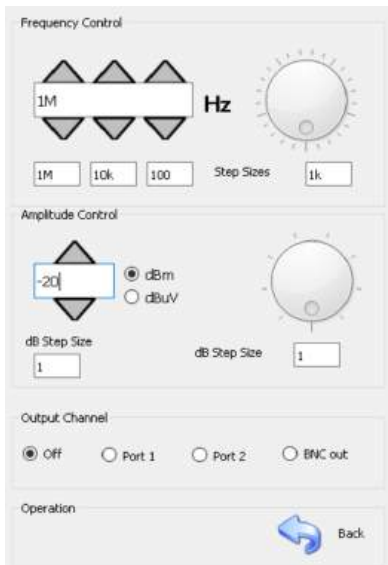

Figure 1-157 Signal Generator Utility

The TBVNA-6000 can be operated as low noise CW RF signal generator.

Port 1 and Port 2 can be configured to deliver an output signal in the frequency range 0.1 Hz to 6GHz with an amplitude in the range of – 80 dBm to -7 dBm.

The maximum output frequency at the BNC port is limited to 500 MHz. The maximum output power is +24 dBm up to 200 MHz and + 10 dBm for the frequencies from 200 MHz to 500 MHz.

2 Appendix

2.1 Compensation File Format

Two alternative text file formats, a standard format and the EMCview format are supported by the TBVNA-6000 software. In any case, a logarithmic correction value is assigned to a frequency value.

	<p>The TBVNA software supports both a “standard” format and the EMCview correction file format.</p> <p>However, EMCview only supports the EMCview correction file format.</p>
---	---

The standard format is composed of both values in a line, as shown below:

<Frequency in Hz><Separator><Correction Value><Space><dB><CR,LF>

Valid separators are ", " , ";", " ", and Tabulator.

An example of a compensation file with 0 dB gain at 1kHz, 1dB at 2 kHz and 2dB at 3 kHz:

```
1000, 0.0 dB
2000, 10.0 dB
3000, 20.0 dB
```

Examples with other separators:

```
1000;0.0 dB
```

or

```
1000 1.0 dB
```

The frequency values must be in ascending order

The EMCview compensation file format has the frequency and corresponding correction value in consecutive lines:

```
[Application]
[Data]
Freq1=250000000
Lev1=17.77
Freq2=255000000
Lev2=15.74
Freq3=260000000
Lev3=14.34
Freq4=265000000
Lev4=14.23
Freq5=270000000
Lev5=14.27
```

For further information on the EMCview File format, please consult the corresponding manuals.

2.2 Time domain measurements.

Time domain analysis is a useful tool for measuring impedance values along transmission lines or for evaluating a discontinuity in time and distance. The time domain display often provides a much more intuitive insight into the DUT (device under test) behavior compared to a frequency domain plot. Broadband performance can be observed by identifying each discontinuity by time or distance. Although the VNA provides a TDR display, there are differences between a traditional TDR meter using discrete pulses and the VNA frequency sweep method. The VNA time domain modes can be separated in two major methods:

- Low Pass mode
- Band Pass mode

Low Pass mode will use a frequency band starting with DC (or close DC) and a certain stop frequency. The VNA will then extrapolate the DC and assume that the negative frequency values are the conjugate complex of the positive frequency values. An inverse FFT calculates the time domain behavior. Each frequency step from DC to the stop frequency is equidistant.

In Band Pass mode the analyzer will use the Start and Stop frequency and a number of equidistant frequency points in between. Through the low noise receiver of the VNA the noise performance is superior to traditional TDR instruments. The band pass mode is very useful when measuring with in an IF range or filter range, where sweeping down to DC is impossible.

The XC-8752A provides four times four different time domain functions:

TDR_Sxx_LP_RW : Sxx parameter low pass mode time domain transform with rectangular window.

TDR_Sxx_LP_HW : Sxx parameter low pass mode time domain transform with Hamming window.

TDR_Sxx_BP_RW : Sxx parameter band pass mode time domain transform with rectangular window.

TDR_Sxx_BP_HW : Sxx parameter band pass mode time domain transform with Hamming window.

Each mode can be applied to any of the four S-parameters.

When using the low-pass mode, it is recommended to select TDR as frequency sweep mode:

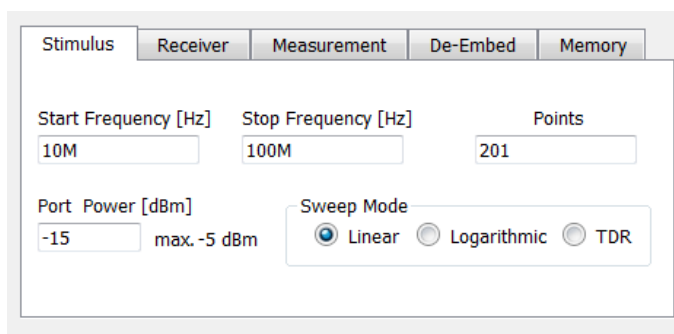

Figure 2-1 VNA sweep modes.

Now, the start frequency can be set to zero. The number of points must fulfill the condition 2^{n+1} . This means for example 257, 513, 1025 or 2049 points.

For the bandpass mode, choose linear as frequency sweep type and select a proper start- and stop frequency.

Application: Fault location

When viewing a filter's transmission response, ripple may appear due to reflection. However it is impossible to tell where in the filter setup the problem occurs. What is seen is the total reflection of cables, connectors, transmission lines and the filter structure. With the time domain analysis tool, the discontinuities are separated in time/distance and any inductive or capacitive mismatch can easily be identified. This gives an intuitive insight into fault location.

Application: Impedance variation

To determine the discontinuity in transmission lines the TDR function can be used to analyze the S11 parameter. S11 is a measurement of how different the DUT's impedance is from the system's characteristic impedance Z_0 . Once the time domain function has been applied, the impulse response can be used to analyze the position and magnitude of the impedance changes.

Application: Filter tuning

Time domain measurements can show the individual responses of resonators and coupling apertures, each filter can be tuned individually. A clear representation is not easily possible in the frequency domain since the interactive nature of coupled-resonator structures makes it difficult to decide which filter element needs to be tuned. The TDR measurements can significantly reduce tuning time in production.

Low Pass Mode	Band Pass Mode
Emulates traditional TDR	Like narrow band time domain
DC value extrapolated	General purpose mode
Equidistant span from DC to stop frequency	Any arbitrary frequency range
Twice the resolution than the bandpass mode	
Good for seeing small responses in devices that passes low frequencies like cable	Best for measuring band limited devices such as filters. Also useful for fault location, but cannot determine the type of discontinuity

Figure 2-2 time domain mode features.

For deeper understanding of the time domain analysis, please consult the available literature on this topic.

2.3 VNA component measurements

The VNA implements following measurement functions for the measurement of electronic components:

<series RC> R-C in series equivalent, Real = R, Imag = C	Calculates R-C equivalent series circuit from S_{11} . Resistance in Ohm is the real-value, capacitance in farad is the imaginary value.
<parallel RC> R-C in parallel equivalent, Real = R, Imag = C	Calculates R-C equivalent parallel circuit from S_{11} . Resistance in Ohm is the real-value, capacitance in farad is the imaginary value.
<series LR> R-L in series equivalent, Real = R, Imag = L	Calculates R-L equivalent series circuit from S_{11} . Resistance in Ohm is the real-value, Inductance in Henry is the imaginary value.
<parallel LR> R-L in parallel equivalent, Real = R, Imag = L	Calculates R-L equivalent parallel circuit from S_{11} . Resistance in Ohm is the real-value, Inductance in Henry is the imaginary value.
<IMP Series> Impedance measurement by Series Method	Two port method for measuring complex impedance
<IMP Shunt> Impedance measurement by Shunt Method	Two port method for measuring complex impedance

Figure 2-3 Component measurement functions.

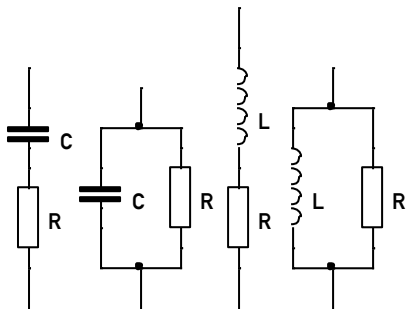

Figure 2-4 Four different component network representations measured by the four functions. From left to right: R-C in series, R-C in parallel, R-L in series, R-L in parallel.

The component values will be derived from an S_{11} or S_{22} measurement. The real part of the function represents the ohmic part R in Ohms, while the imaginary parts represent L in Henries or C in Farads. The measurement functions are based one of the four circuit representations displayed in Figure 2-3.

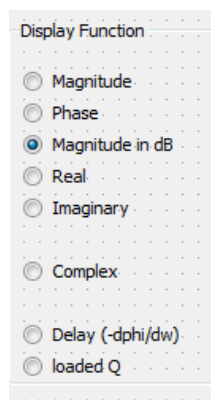

Figure 2-5 Display Function in trace edit window.

Choose "Real" or "imaginary" as display function in the trace edit window to set a trace to the Ohmic or imaginary component value over frequency.

Impedance Measurement applying the Shunt Method.

This method allows to measure low impedance values (< 1 Ohm) more accurately compared to single port measurements ($S_{11} \rightarrow Z$). Connect two measurement cables to Port 1 and 2. Connect both cables to establish a through connection. Perform a simple Through calibration with the IDEAL calibration standard selected. Then, connect the unknown impedance between the through connection and ground. Be sure to use short connections, best use an appropriate adapter. Now select the IMP Shunt trace function. The resulting Real and Imaginary values correspond to the unknown impedance Z. To improve the accuracy of this method at low frequencies, an RF common mode choke is usually inserted into the path from DUT to Port P2 .

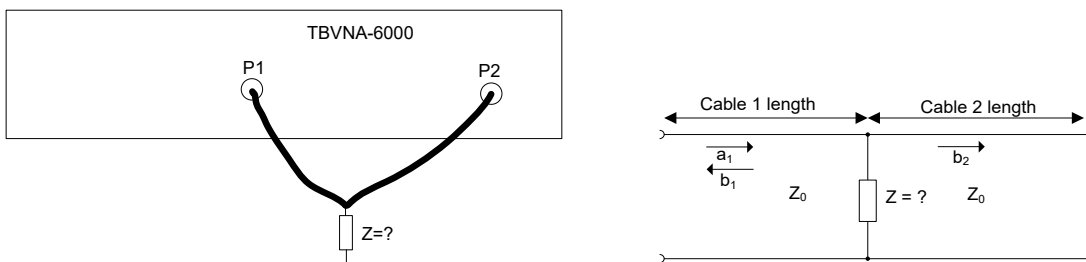

Figure 2-6 Shunt measurement setup

The underlying function to calculate Z is:

$$Z = Z_0 \frac{S_{21}}{2(1 - S_{21})}$$

Impedance Measurement by the Series Method.

This method will allow accurate measurements of high impedances in the range of 50 Ω to several kΩ accurately. Connect two measurement cables to Port 1 and 2. Connect both cables to establish a through connection. Next perform a simple Through calibration with the IDEAL calibration standard selected. Next, insert the unknown impedance into the through connection, in series. Use short connections, or better use an appropriate adapter. Next, select the IMP Series trace function. The resulting Real and Imaginary values correspond to the unknown impedance Z.

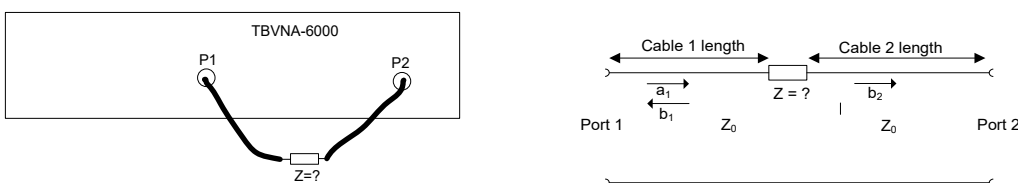

Figure 2-7 Series measurement setup

The underlying function to calculate Z is:

$$Z = Z_0 \frac{2(1 - S_{21})}{S_{21}}$$

2.4 Loaded Q measurement

Loaded Q is an important parameter in filter and resonator characterization. The loaded Q value is calculated by the equation:

$$Q_l = -\frac{d\phi}{d\omega} \frac{\omega}{2} = \frac{t_{gr}\omega}{2}$$

and can be applied on all Sxx parameters. It represents the quality factor of a DUT under loaded conditions.

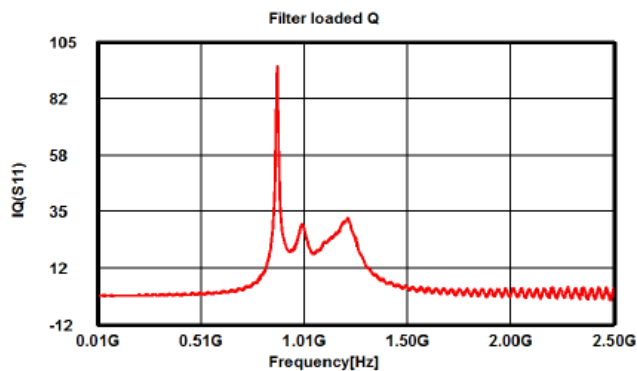

Figure 2-8 Filter, example plot of loaded Q

2.5 Calibration standards File Format

The calibration standards file format is explained in order to be able to manually enter standard calibration data in* .xsf format

The "standard" file is a text file which can be edited with any ASCII text editor. Standard files format:

Comments:

Syntax: ! <comment>

Comments shall begin with the character "!" followed by a space. There can be any number of character lines in a file.

Description:

Syntax: .NAME <description>

The description text is displayed in the calibration menu and has only informational purpose.

Calibration type:

Syntax: .CALMODE <type = P_2 | P_1 >

sets the type of standards, if the file is a two port standard definition "P_2" or a one port definition "P_1". A one port definition will only contain open/short and load definition for Port 1.

Standards:

Short standard Port 1/2:

Syntax: .STANDARD_SHORT_P1_P <L0><L1><L2><L3><delay><loss><Z0>

Syntax: .STANDARD_SHORT_P2_P <L0><L1><L2><L3><delay><loss><Z0>

Parameter	Meaning
L0	Polynomial coefficient for inductor in [H]
L1	Polynomial coefficient for inductor in [H/Hz]
L2	Polynomial coefficient for inductor in [H/Hz ²]
L3	Polynomial coefficient for inductor in [H/Hz ³]
delay	Transmission line delay from reference plane to short in [s]
loss	Transmission line loss in [GOhm/s]
Z ₀	Transmission line characteristic impedance

Figure 2-9 standard definition for SHORT standard

Open standard Port 1/2:

Syntax: .STANDARD_OPEN_P1_P <C0><C1><C2><C3><delay><loss><Z0>

Syntax: .STANDARD_OPEN_P2_P <C0><C1><C2><C3><delay><loss><Z0>

Parameter	Meaning
C0	Polynomial coefficient for capacitor in [H]
C1	Polynomial coefficient for capacitor in [H/Hz]
C2	Polynomial coefficient for capacitor in [H/Hz ²]
C3	Polynomial coefficient for capacitor in [H/Hz ³]
delay	Transmission line delay from reference plane to open in [s]
loss	Transmission line loss in [GOhm/s]
Z ₀	Transmission line characteristic impedance

Figure 2-10 standard definition for SHORT standard

Load standard Port 1/2:

Syntax: .STANDARD_LOAD_P1_P <Z0><delay>

Syntax: .STANDARD_LOAD_P2_P <Z0><delay>

Parameter	Meaning
delay	Transmission line delay from reference plane to open in [s]
Z ₀	Transmission line characteristic impedance

Figure 2-11 standard definition for LOAD standard

Through Standard:

Syntax: .STANDARD_THRU_P <delay><loss><Z0>

Parameter	Meaning
delay	Transmission line electrical length in [s]
loss	Transmission line loss in [GOhm/s]
Z ₀	Transmission line characteristic impedance

Figure 2-12 standard definition for THRU standard

2.6 VNA gain measurement function

The instrument provides multiple gain functions to characterize amplifier two ports:

<Gvf> matched voltage gain forward	Complex V_2/V_1 voltage ratio with termination on Port 2
<Gvr> matched voltage gain reverse	Complex V_1/V_2 voltage ratio with termination on Port 1
<Gif> matched current gain forward	Complex I_2/I_1 current ratio with termination on Port 2
<Gir> matched current gain reverse	Complex I_1/I_2 current ratio with termination on Port 1
<k> stability factor	Stability of a two port if $k > 1$
<Gms> maximum stable gain	Maximum stable gain of a two port
<Gmax> maximum available gain	Maximum available gain of a two port
<Gvfo> open output voltage gain forward	Complex V_2/V_1 voltage ratio with open Port 2
<Gifs> short output current gain forward	Complex I_2/I_1 current ratio with open Port 2
<Gvfa> arbitrary load output voltage gain forward (use optional value)	Complex V_2/V_1 voltage ratio with resistance on Port 2 given by the optional input field.
<Gifa> arbitrary load output current gain forward (use optional value)	Complex I_2/I_1 current ratio with resistance on Port 2 given by the optional input field.
<Gtp> Transducer Gain	Calculates the two port transducer gain using an arbitrary output Port 2 load defined by the optional value

Figure 2-13 gain related functions

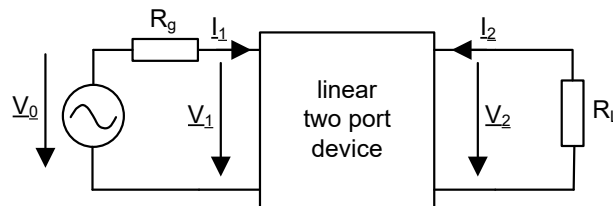

Figure 2-14 Definition of a linear two port device under test

Figure 6.8 shows a linear two port device under test. V_0 with R_G denote the source port, with $R_G = Z_0 = 50 \text{ Ohm}$. The resistor R_L denote the load port, with $R_L = Z_0$. V_1 , V_2 are the port voltages and I_1 , I_2 the port currents.

G_{vf} Matched forward voltage gain

The measurement of G_{vf} follows the schematics on Figure 6.8. This functions calculates the complex voltage gain in forward direction with the assumption that $R_G = R_L = Z_0$.

$$G_{vf} = \left. \frac{V_2}{V_1} \right|_{R_G=R_L=Z_0}$$

G_{vr} Matched reverse voltage gain

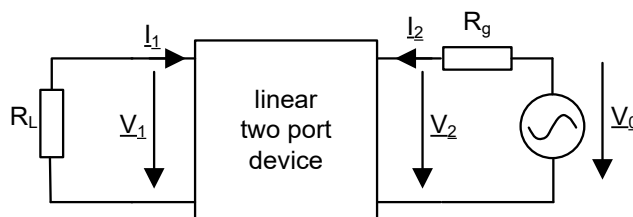

Figure 2-15 Definition of a linear two port device under test in reverse direction

The measurement of G_{vr} follows the schematics on Figure 6.9. This functions calculates the complex voltage gain in forward direction with the assumption that $R_G = R_L = Z_0$.

$$G_{vr} = \left. \frac{V_1}{V_2} \right|_{R_G=R_L=Z_0}$$

G_{if} Matched forward current gain

The measurement of G_{if} follows the schematics in Figure 6.8. This functions calculates the complex current gain in forward direction with the assumption that $R_G = R_L = Z_0$.

$$G_{if} = \left. \frac{I_2}{I_1} \right|_{R_G=R_L=Z_0}$$

G_{ir} Matched reverse current gain

The measurement of G_{ir} follows the schematics in Figure 6.9. This functions calculates the complex current gain in reverse direction with the assumption that $R_G = R_L = Z_0$.

$$G_{ir} = \left. \frac{I_1}{I_2} \right|_{R_G=R_L=Z_0}$$

k Stability Factor

The stability factor k is used in amplifier design as a stability criteria. A k factor of greater than 1 guarantees unconditional stability (under all source and load conditions).

$$k = \frac{1 - |S_{11}|^2 - |S_{22}|^2 + |\Delta|^2}{2|S_{21}S_{12}|}$$

$$\text{with } \Delta = S_{11}S_{22} - S_{12}S_{21}$$

G_{ms} Maximum stable gain

The maximum stable gain G_{ms} of a device is defined when maximum available gain is undefined ($k < 1$). It is the ratio of $\text{mag}(S_{21})/\text{mag}(S_{12})$. It is not advised to get more than this amount of gain from a conditionally stable device. It is recommended to try to stabilize the device using resistive components, until k is greater than 1, then optimize the matching networks for the required gain.

G_{max} Maximum available gain

The maximum available gain G_{max} of a device is only defined where k is greater than one. Algebraically, this is because the term under the square-root becomes negative for values of k less than 1. Another way to look at it is that maximum available gain is infinite. Infinite gain means oscillations.

$$G_{max} = \left(k - \sqrt{k^2 - 1} \right) \left| \frac{S_{21}}{S_{12}} \right|$$

G_{vfo} Forward voltage gain with no load

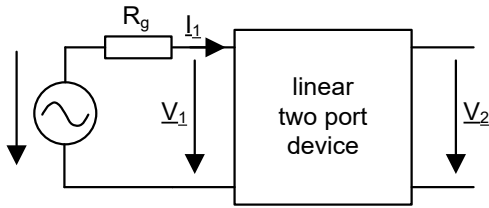

Figure 2-16 Definition of a linear two port device with open output

For this gain it is assumed that the load resistor $R_L = \infty$, although the measurement will be done like shown in Figure 6.8.

$$G_{vfo} = \left. \frac{V_2}{V_1} \right|_{R_G=Z_0, R_L=\infty}$$

G_{ifs} Forward current gain with output short circuited

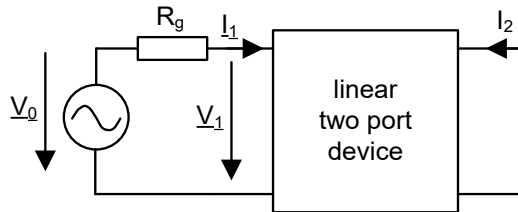

Figure 2-17 Definition of a linear two port device with shorted output port

For this gain it is assumed that the load resistor $R_L = 0$, although the measurement will be done like shown in Figure 6.8.

$$G_{ifs} = \left. \frac{I_2}{I_1} \right|_{R_G=Z_0, R_L=0}$$

G_{vfa} Forward voltage gain with arbitrary load

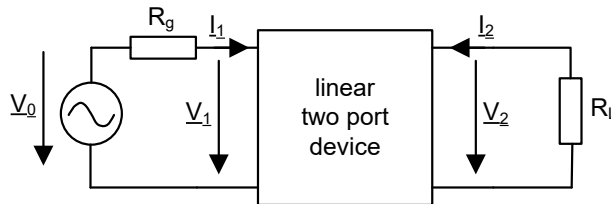

Figure 2-18 Definition of a linear two port device under test

For this gain it is assumed that the load resistor R_L is set by the option value in the trace edit field, although the measurement will be done like shown in Figure 6.12.

$$G_{vfa} = \left. \frac{V_2}{V_1} \right|_{R_G=Z_0, R_L=arbitrary}$$

G_{ifa} Forward current gain with arbitrary load

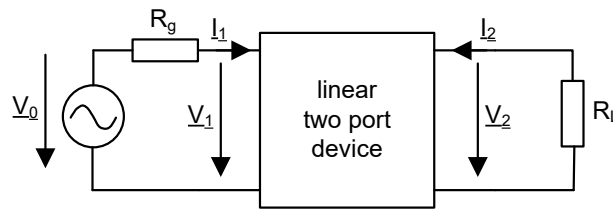

Figure 2-19 Definition of a linear two port device under test

For this gain it is assumed that the load resistor R_L is set by the option value in the trace edit field, although the measurement will be done like shown in Figure 6.13.

$$G_{ifa} = \frac{I_2}{I_1} \Big|_{R_G=Z_0, R_L=arbitrary}$$

G_{tp} Forward transducer gain with arbitrary load.

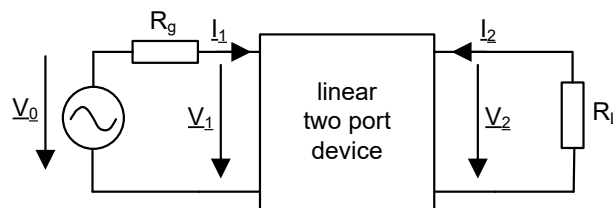

Figure 2-20 Definition of a linear two port device under test.

This gain is a power gain and it is assumed that the load resistor R_L is set by the option value in the trace edit field, although the measurement will be done like shown in Figure 6.14

$$G_{TP} = \frac{|S_{21}|^2 (1 - |\Gamma_L|^2)}{|1 - S_{22}\Gamma_L|^2} \text{ under the condition that } R_G = Z_0.$$

2.7 Nyquist Plots in Bode Mode

The Bode analyzer is subject to an additional manual and application notes.

3 Specifications

VNA specifications

Measured parameters	$S_{11}, S_{12}, S_{21}, S_{22}$
Measurement channels	Four parallel receiver chains
Data traces	Arbitrary number of traces and diagrams
Memory traces	Four full S-parameter memory slots
Data display formats	Rectangular, polar and smith diagram, over 50 trace functions, including time domain and group delay.
Sweep type	Linear and Logarithmic
Sweep trigger	Continuous, Single, Hold
Measured points per sweep	2 - 100000
Power settings	1 Hz – 500 MHz: -6 dBm to -50 dBm 500 MHz - 4 GHz: - 5 dBm to – 70 dBm 4 GHz – 6 GHz: - 10 dBm to – 70 dBm in 0.25 dB steps
Trace math	Normalization, Magnitude, Phase, Log, Real, Imag, Complex, Delay; Powerful equation editor for user defined measurements
De-embedding	Port Extension with loss, delay and Z_0 adjustment, full de-embedding.
Calibration	SOLT (short, open, load, through), normalization
Calibration types	Simple through, 1-port or full 2-port DC-offset calibration
Measurement bandwidth	0.01 Hz - 400 kHz adjustable
Frequency range	0.1 Hz - 6000 MHz
Frequency step resolution	0.001 Hz
Setups	Arbitrary number of user - defined setups
Output signal amplitude accuracy (typ.)	+/- 1 dB @ -10 dBm to -25 dBm +/- 2 dB @ -25 dBm to -40 dBm +/- 2 dB @ -40 dBm to -80 dBm
Measurement speed (typ.)	250us / frequency point @ 400 kHz RBW unidirectional measurement
Frequency accuracy	+/- 25 ppm
Port 1, Port 2 impedance	50 Ω DC-coupled
RF input return loss	Better -20 dB to 1.5 GHz, better -10 dB to 6 GHz
Port 1, Port 2 connectors	N-Female
Operating temperature	0°C - 40°C ambient
Operating humidity	0% to 80% rel. humidity
Operating voltage	100-120 VAC / 200 - 240 VAC, 50-60 Hz; internal linear power supply with mains voltage selection switch
Power consumption	30 Watt max.
Connection	USB 2.0, Full-Speed

Spectrum analyzer and Phase Noise analyzer utility

Frequency range	0.1 Hz - 6000 MHz
Unambiguous frequency range	0.1 Hz - 60 MHz
Parallel channels	2
Resolution bandwidth	0.1 Hz - 3 MHz
Frequency step resolution	0.1 Hz
Frequency accuracy	+/- 25 ppm
Amplitude accuracy	+/- 1.5 dB typ.
Low spurs technology (sideband suppression)	Multi frequency sampling
Frequency points	Arbitrary
Display functions	RMS, Minimum, Maximum and Average, Correlation
Maximum linear input power	20 dBm (attenuator "on")
Phase noise (low noise mode) @ 300 MHz	< -90 dBc @ 100 Hz offset
	< -115 dBc @ 1kHz offset
	< -115 dBc @ 10kHz offset
	< -115 dBc @ 100kHz offset
	< -125 dBc @ 1MHz
Input noise voltage	< 30 nV/Sqrt(Hz) @ f > 10 kHz

CW Signal Generator utility

Frequency range	0.001 Hz - 6.0GHz
Frequency step resolution	0.001 Hz
Output power range	-6 dBm to -50 dBm (0.001 Hz to 500 MHz)
	-5 dBm to < -80 dBm (500 MHz to 6 GHz)
Output signal amplitude accuracy (typ.)	+/- 2 dB @ -5 dBm to -25 dBm
	+/-2.5 dB @ -25 dBm to -40 dBm
	+/-3 dB @ -40 dBm to -80 dBm
Phase noise (low noise mode) @ 300 MHz	<-90 dBc @ 100 Hz offset
	< -115 dBc @ 1kHz offset
	< -115 dBc @ 10kHz offset
	< -115 dBc @ 100kHz offset
	< -125 dBc @ 1MHz

Oscilloscope, Voltmeter

Resolution	14 Bit (up to 16Bits with CIC Filter)
Channels	4
Input range	Max. +/- 3V, +/-20V with BODE
Memory	Max. 8192 points
Lowpass Filter	CIC type, adjustable
Sampling range (real)	15 S/s - 125 MS/s
Sampling range (Sin(x)/x)	250 MS/s - 4 GS/s
Bandwidth	60 MHz (Nyquist), 500 MHz (real)
Protocol analyzer	SPI, I2C, RS232
Measurement functions	24 measurement functions like RMS, period..
Trigger Modes	Edge Trigger, Pulse Trigger, Manual, Auto, A->B
Trigger Delay	0 - 1020 samples
Input	50 Ohms single ended , 1 MOhm // 15 pF with Option BODE
Special	Trigger aperture and HF Suppression filters

High impedance inputs

Input Impedance	1 M Ω // 15 pF
Frequency Range	0 - 500 MHz +/- 20V and +/- 5V range, 250 MHz +/- 0.5 V range
Offset	< 1 mV
Voltage ranges	3, +/- 20V, +/- 5V, +/- 0.5 V

Bode Analyzer

Measured parameters	Absolute level P_1 , P_2 , P_A , P_B and all ratios like P_B/P_A , P_2/P_1 etc.
Measurement channels	4 channels P_1 , P_2 with 50 Ohms and P_A , P_B with 1 M Ω // 15 pF
Data display formats	Rectangular and polar diagram, over 10 trace functions, including time group delay.
Sweep type	Linear and Logarithmic
Sweep trigger	Continuous, Single, Hold
Measured points per sweep	2 - 100000
Power settings	0.001 Hz – 200 MHz: + 24 dBm to – 17 dBm in 0.1 dB steps 200 MHz – 500 MHz: +10 dBm to – 17 dBm in 0.1 dB steps
Trace math	Normalization, Magnitude, Phase, Log, Real, Imag, Complex, Delay; Powerful equation editor for user defined measurements
Measurement bandwidth	0.001 Hz - 400 kHz adjustable
Frequency range	0.001 Hz - 500 MHz
Frequency step resolution	0.001 Hz
Setups	Arbitrary number of user - defined setups

Measurement speed (max.)	250us / frequency point @ 400 kHz RBW
Frequency accuracy	+/- 25 ppm
Port 1, Port 2 impedance	50 Ω DC-coupled
RF input return loss	< 1 : 1.15 @ 10 ... 30dB attenuation < 1 : 1.5@ 0 ... 30dB gain
Port 1, Port 2 range	0 dBm max.
Port 1, Port 2 connectors	N-Female
Port A, Port B impedance	1 M Ω // 15 pF , DC-coupled
Port A, Port B voltage range	+/-20V, +/-5V and +/- 0.5V
Port A, Port B connectors	BNC

Port 1 & 2 Maximum Input Power Levels

Attenuation [dB]	Absolute Max. Input Level [dBm, dB μ V, V]
0	+5 dBm, 112 dBμV, 0.57V
20	+20 dBm, 127 dBμV, 3 V

Port A & B Maximum Input Voltage Levels

Attenuation [dB]	Absolute Max. Input Level [V]
+/- 20V range	+/- 25 V
+/- 5V range	+/- 7 V
+/- 0.5V	+/- 1 V

4 Ordering Information

Part Number	Description
TBVNA-6000	0.1 Hz – 6 GHz Vector Network Analyzer
TBVNA-6000-B	0.1 Hz – 6 GHz Vector Network Analyzer with Bode option

5 History

Version	Date	Application SW version	Changes
1.0	12.4.2025		
1.1	18.8.2025	1.3.2 and higher	Added new SW features

The application software version refers to the most recent version available at the time of writing the operating manual.