

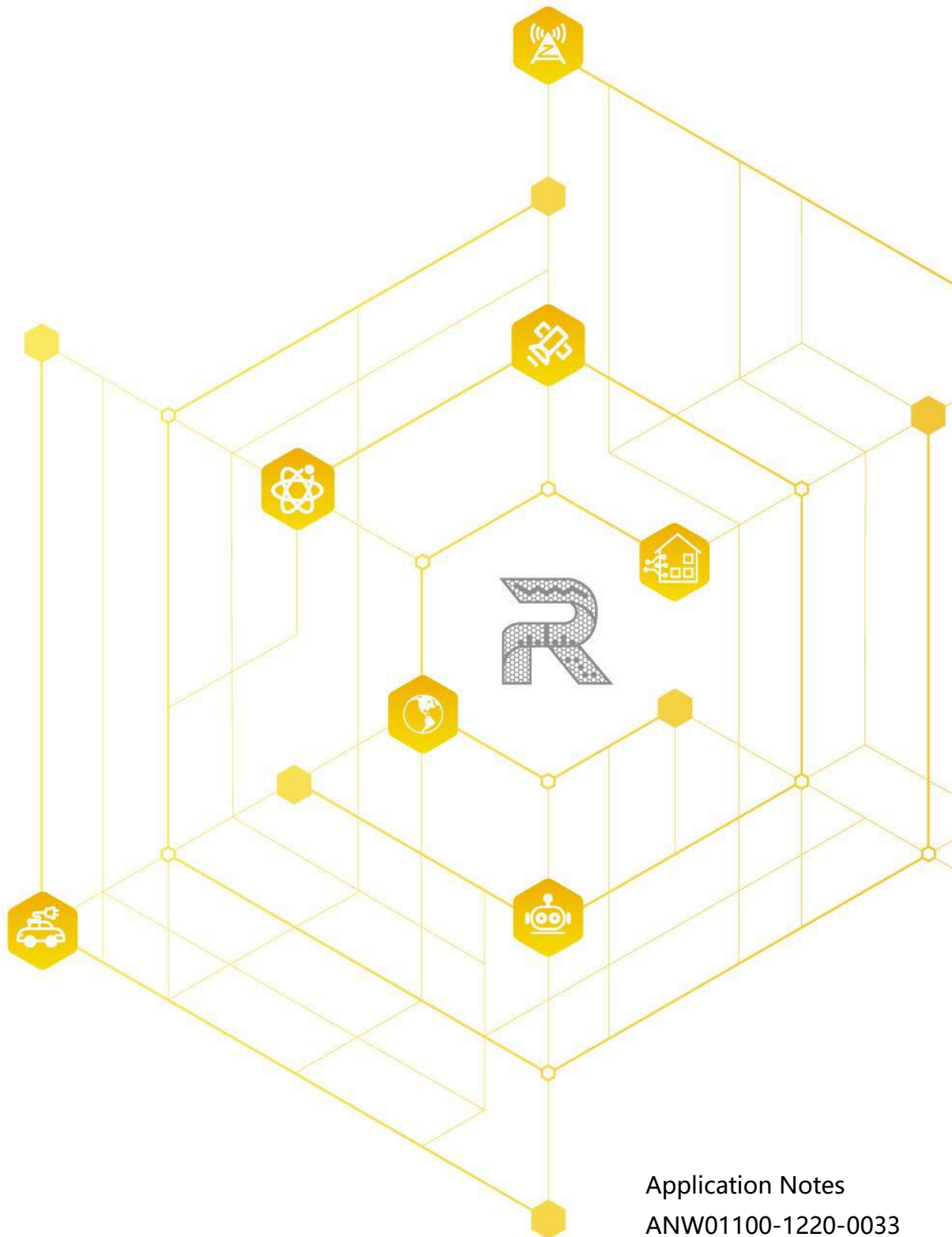

MHO/DHO5000 Series Digital Oscilloscope

Application Guide for Bode Plot Function



Overview

A Bode plot is a graph that maps the frequency response of the system. It was first introduced by Hendrik Wade Bode in 1940.

The Bode plot consists of the Bode magnitude plot and the Bode phase plot. Both the amplitude and phase graphs are plotted against the frequency. The horizontal axis is $\lg\omega$ (logarithmic scale to the base of 10), and the logarithmic scale is used. The vertical axis of the Bode magnitude plot is $20\lg$ (dB), and the linear scale is used, with the unit in decibel (dB). The vertical axis of the Bode phase plot uses the linear scale, with the unit in degree ($^{\circ}$). Usually, the Bode magnitude plot and the Bode phase plot are placed up and down, with the Bode magnitude plot at the top, with their respective vertical axis being aligned. This is convenient to observe the magnitude and phase value at the same frequency, as shown in the following figure.

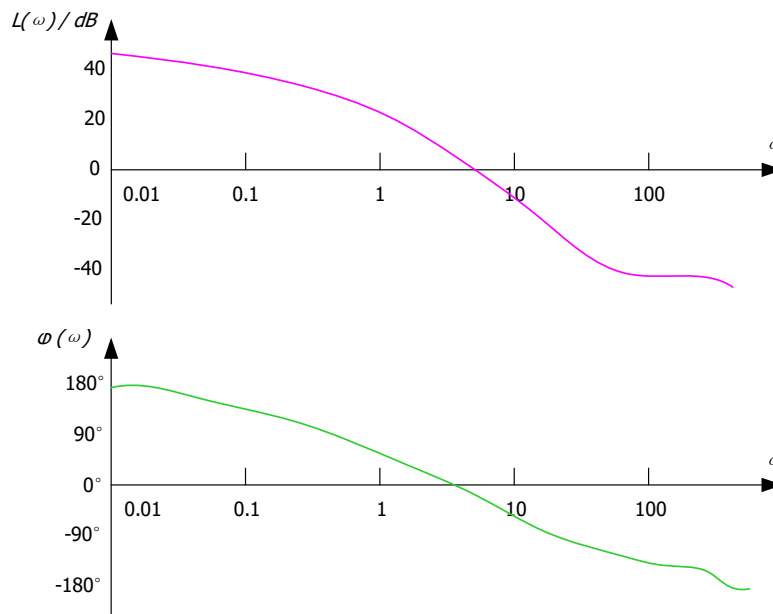

The loop analysis test method is as follows: Inject a sine-wave signal with constantly changing frequencies into a switching power supply circuit as the interference signal, and then judge the ability of the circuit system in adjusting the interference signal at various frequencies according to its output.

This method is commonly used in the test for the switching power supply circuit. The measurement results of the changes in the gain and phase of the output voltage can be output to form a curve, which shows the changes of the injection signal along with the frequency variation. The Bode plot enables you to analyze the gain margin and phase margin of the switching power supply circuit to determine its stability.

Principle

The switching power supply is a typical feedback loop control system, and its feedback gain model is as follows:

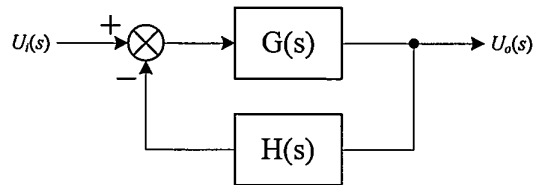

In the feedback circuit system, the relationship between the output voltage $U_o(s)$ and the reference voltage $U_i(s)$ is as follows:

open-loop transfer function: $T(s) = G(s) * H(s)$

closed-loop transfer function: $\frac{U_o(s)}{U_i(s)} = \frac{G(s)}{1+G(s)*H(s)} = \frac{G(s)}{1+T(s)}$

voltage fluctuation expression: $\Delta U_o(s) = \frac{G(s)}{1+T(s)} * \Delta U_i(s)$

From the above formula, you can find out the cause for the instability of the closed-loop system: Given $1 + T(s) = 0$, the interference fluctuation of the system is infinite.

The instability arises from two aspects:

- 1) when the magnitude of the open-loop transfer function is $|T(s)| = 1 = 0dB$
- 2) when the phase of the open-loop transfer function is $\angle T(s) = -180^\circ$

The above is the theoretical value. In fact, to maintain the stability of the circuit system, you need to spare a certain amount of margin. Here we introduce two important terms:

- PM: phase margin.

When the gain $|T(s)|$ is 1, the phase $\angle T(s)$ cannot be -180° . At this time, the distance between $\angle T(s)$ and -180° is the phase margin. PM refers to the amount of phase, which can be increased or decreased without making the system unstable. The greater the PM, the greater the stability of the system, and the slower the system response.

- GM: gain margin.

When the phase $\angle T(s)$ is -180° , the gain $|T(s)|$ cannot be 1. At this time, the distance between $|T(s)|$ and 1 is the gain margin. The gain margin is expressed in dB. If $|T(s)|$ is greater than 1, then the gain margin is a positive value. If $|T(s)|$ is smaller than 1, then the gain margin is a negative value. The positive gain margin indicates that the system is stable, and the negative one indicates that the system is unstable.

The following figure is the Bode plot. The curve in purple shows that the loop system gain varies with frequency. The curve in green indicates the variation of the loop system phase with frequency. In the figure, the frequency at which the GM is 0 dB is called "crossover frequency".

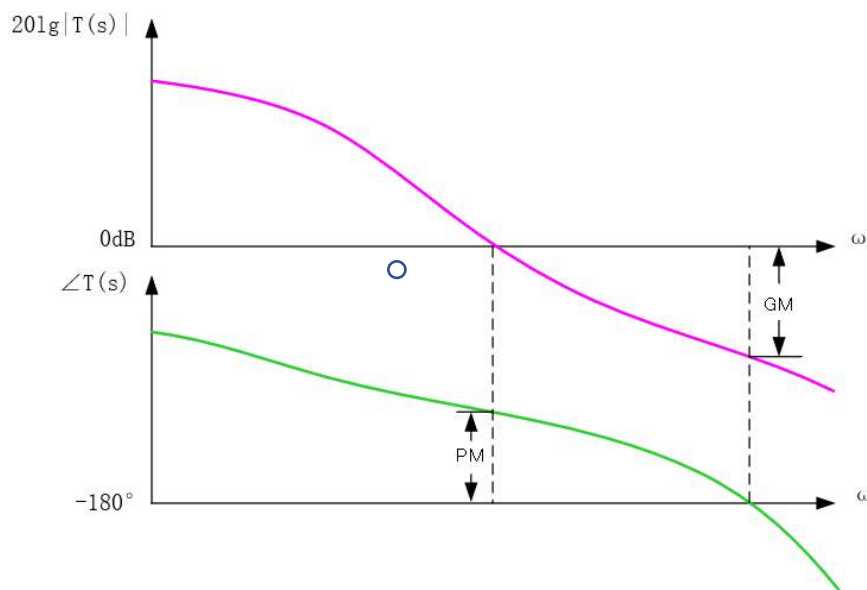

The principle of the Bode plot is simple, and its demonstration is clear. It evaluates the stability of the closed-loop system with the open-loop gain of the system.

Loop Test Environment Setup

RIGOL MHO5054 and MHO5104 have built-in 50 MHz function/arbitrary waveform generator and support the Bode Plot function. The following figure is the circuit topology diagram of the loop analysis test for the switching power supply by using **RIGOL**'s MHO5054 series digital oscilloscope. The loop test environment is set up as follows:

1. Connect a 5Ω injection resistor R_{inj} to the feedback circuit, as indicated by the red circle in the following figure.
2. Connect the GI connector of the MHO5054 series digital oscilloscope to an isolated transformer. The swept sine-wave signal output from the oscilloscope's built-in waveform generator is connected in parallel to the two ends of the injection resistor R_{inj} through the isolated transformer.
3. Use the probe that connects the two analog channels of the MHO5054 series digital oscilloscope (e.g. **RIGOL**'s RP3500A probe) to measure the injection and output ends of the swept signal.

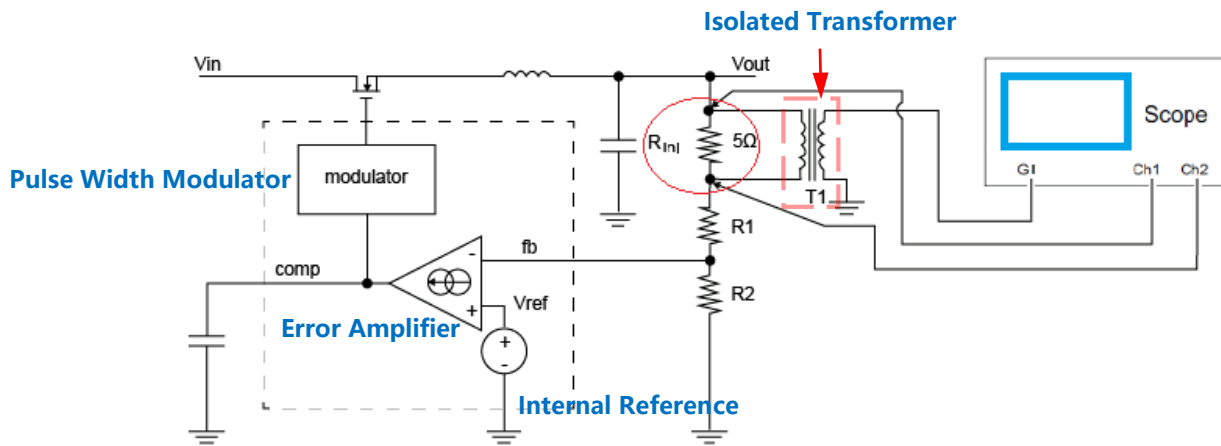

The following figure is the physical connection diagram of the test environment.



Operation Procedures

The following section introduces how to use **RIGOL**'s MHO5054 series digital oscilloscope to carry out the loop analysis. The operation procedures are shown in the figure below.

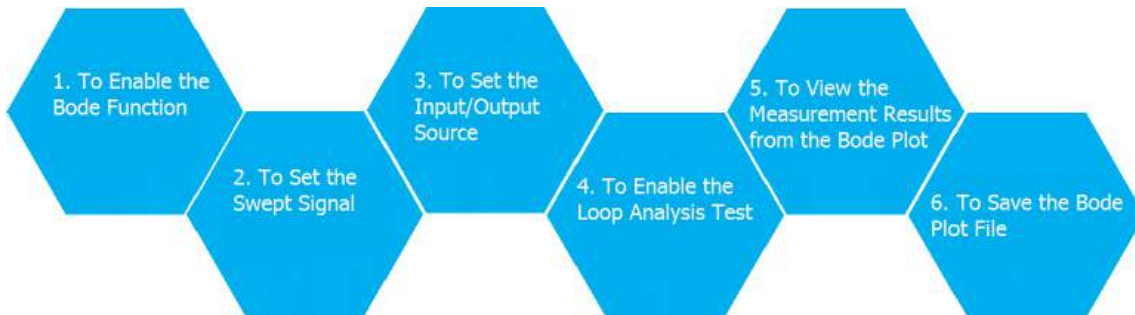

Step 1 To Enable the Bode Plot Function

Click or tap the function navigation icon  at the lower-left of the screen, and select **Bode Plot** to open the Bode plot setting menu.

Step 2 To Set the Swept Signal

Click or tap **Ampl/Freq Setting** to enter the following setting menu. You can click or tap the input field of various items to set the parameters with the pop-up numeric keypad. Click or tap **Var.Amp.** continuously to enable or disable the voltage amplitude of the swept signal in the different frequency ranges.

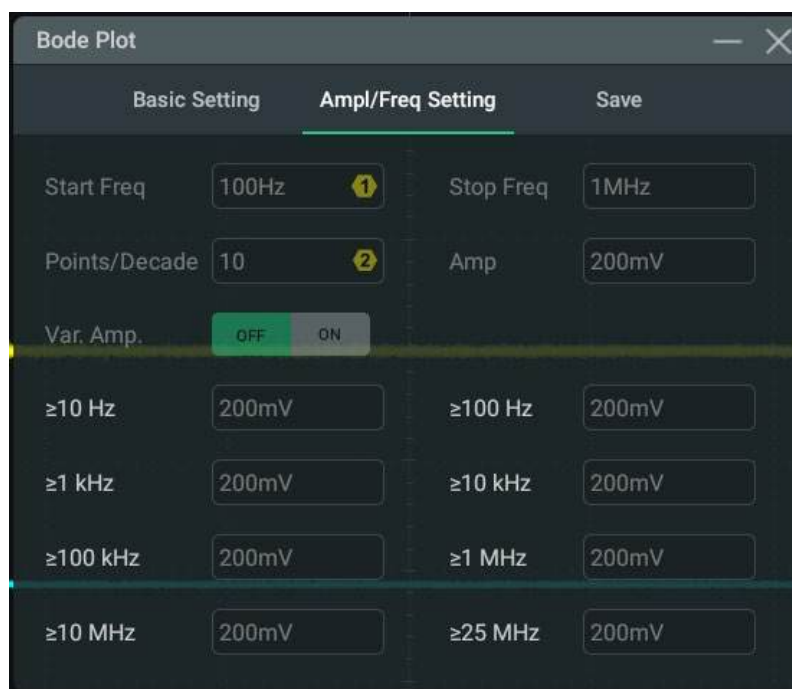

The definitions for the parameters on the screen are shown in the following table.

Parameter	Definition
Start Freq	Indicates the start frequency of the sine wave. The default is 100 Hz, and the range available is from 10 Hz to 3 MHz.
Stop Freq	Indicates the stop frequency of the sine wave. The default is 1 MHz, and the range available is from 100 Hz to 30 MHz.
Points/decade	Indicates the number of displayed points per decade. The default is 10, and the range is from 10 to 100.
Amplitude	Indicates the voltage amplitude of sine wave when the Var.Amp. key is off.
Variant Amplitude	Indicates the voltage magnitude of sine wave in different frequency ranges when the Var.Amp. key is on.

Note:

The "Stop Freq" must be greater than the "Start Freq".

In the Basic Setting menu, click or tap **Sweep Type** to select the desired sweep type. You can also rotate the multifunction knob to select the desired sweep type, and then press down the knob to select it.

- Lin: the frequency of the swept sine wave varies linearly with the time.
- Log: the frequency of the swept sine wave varies logarithmically with the time.



Step 3 To Set the Input/Output Source

As shown in the circuit topology diagram in **Loop Test Environment Setup**, the input source acquires the injection signal through the analog channel of the oscilloscope, and the output source acquires the output signal of the device under test (DUT) through the analog channel of the oscilloscope. Set the output and input sources by the following operation methods.

Click or tap **In** to select the desired channel. You can also rotate the multifunction knob to select the desired channel, and then press down the knob to select it.

Click or tap **Out** to select the desired channel. You can also rotate the multifunction knob to select the desired channel, and then press down the knob to select it.

Step 4 To Run or Stop the Drawing of the Bode Plot

When the Bode plot is enabled, in the Bode plot interface, click or tap  for **Operating Status** to start the loop analysis and Bode plot drawing based on the current Bode plot settings. In the running status,  is displayed for **Operating Status**. After completing the Bode plot drawing, the icon after the **Operating Status** menu turns out to be .

To stop Bode plot drawing during the drawing process, click or tap  to suspend drawing.

NOTE

After completing the Bode plot test, the Bode plot setting interface is closed automatically. To



open the Bode plot setting interface again, click or tap  at the upper-right corner of the Bode plot window.

Step 5 To View the Measurement Results from the Bode Plot

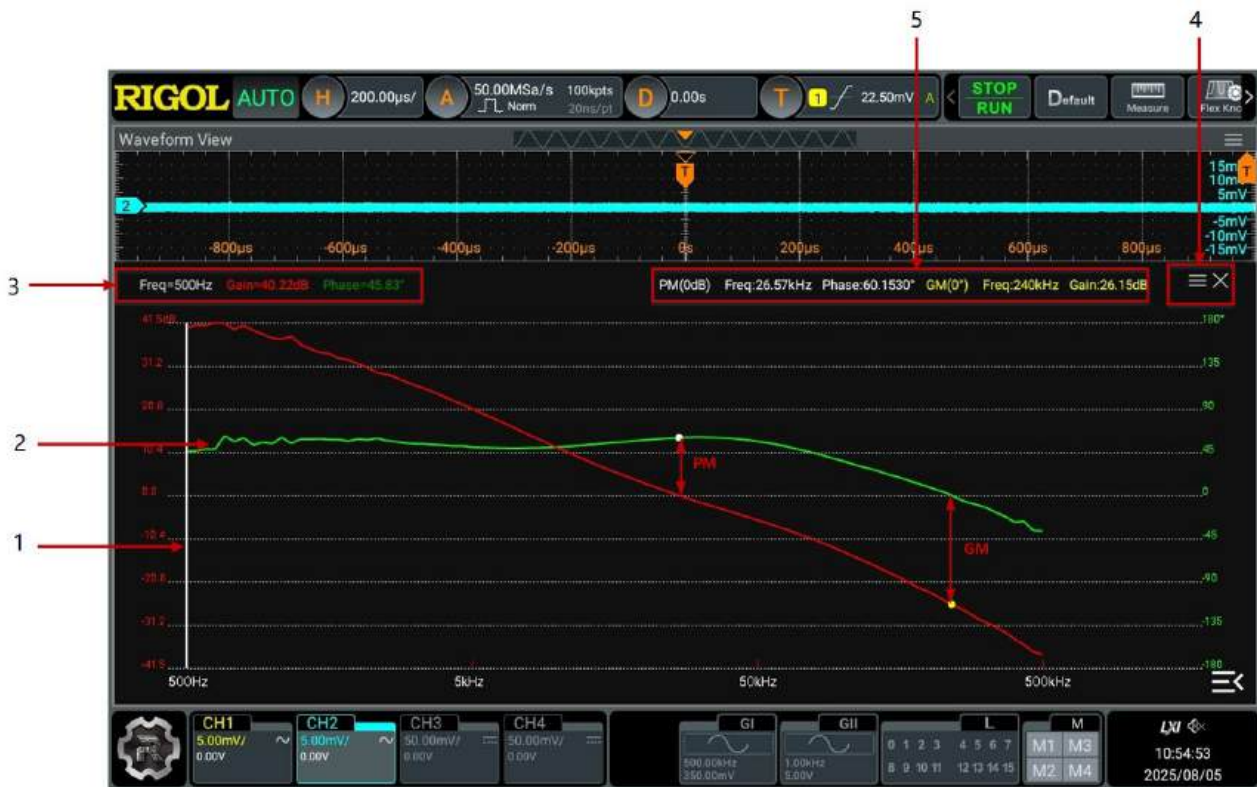
After the Bode plot has been completed drawing, you can view the Bode plot in the Bode Wave window, as shown in the following figure.



The following table lists the descriptions for the main elements in the Bode plot.

No.	Description
1	Cursor: rotate the specified multifunction knob to move the cursor. The cursor information is displayed in the upper-left corner of the Bode plot.
2	Bode plot curves: magnitude-frequency curve (indicated in red) and phase frequency curve (indicated in green).
3	Cursor information display: <ul style="list-style-type: none"> - Freq: indicates the X-axis value where the cursor is located in the Bode plot. - Gain: indicates the Y-axis value of the crossing point between the cursor and the red magnitude-frequency curve. - Phase: indicates the Y-axis value of the crossing point between the cursor and the green phase-frequency curve.
4	Operation button: click or tap  to open the Bode plot setting menu. Click or tap  to close the Bode plot waveform display

	window and disable the Bode function.
5	Phase margin (PM); Gain margin (GM)

Click or tap **Disp Type** to select "Chart" as the display type of the Bode plot. You can also rotate the multifunction knob to select it. The following table will be displayed, and you can view the parameters of the measurement results for loop analysis test.

Index	Freq	Gain	Phase
1	500Hz	40.22dB	45.83°
2	539.88Hz	40.94dB	46.66°
3	582.95Hz	40.89dB	48.42°
4	629.46Hz	41.54dB	48.21°
5	679.67Hz	41.35dB	62.05°
6	733.9Hz	39.96dB	56.17°
7	792.44Hz	40.86dB	59.97°
8	855.66Hz	39.73dB	52.56°
9	923.92Hz	38.82dB	55.50°
10	997.63Hz	37.83dB	53.98°
11	1.0772kHz	37.60dB	60.58°
12	1.1631kHz	38.23dB	54.29°
13	1.2559kHz	36.31dB	58.77°
14	1.3561kHz	35.25dB	58.53°
15	1.4643kHz	34.38dB	58.98°
16	1.5811kHz	34.11dB	58.27°
17	1.7072kHz	32.96dB	58.30°
18	1.8434kHz	32.64dB	56.51°
19	1.9905kHz	31.70dB	58.90°

Step 6 To Save the Bode Plot File

After the test has been completed, save the test results as a specified file type with a specified filename.

Click or tap **Save** to select **Format** for saving the Bode plot. The available file types include ".csv" and ".html". When you select ".csv" and ".html" as the file type, the Bode plot will be saved as a form of chart.

You can also save the Bode Plot by print screen. Click or tap the function navigation icon at the lower-left corner of the screen and select **Storage**. In the Save tab, click or tap the drop-down list of the Format button. The available file types include ".png", ".bmp", and ".jpg". When you select ".png", ".bmp", and ".jpg" as the file type, the Bode plot will be saved as a form of waveform.

Click or tap **File Name**, and input the filename for the Bode plot in the pop-up numeric keypad.

Key Points in Operation

When performing the loop analysis test for the switching power supply, pay attention to the following points when injecting the test stimulus signal.

Selection of the Interference Signal Injection Location

We make use of feedback to inject the interference signal. Generally speaking, in the voltage-feedback switching power supply circuit, we usually put the injection resistor between the output voltage point and the voltage dividing resistor of the feedback loop. In the current-feedback switching power supply circuit, put the injection resistor behind the feedback circuit.

Selection of the Injection Resistor

When choosing the injection resistor, keep in mind that the injection resistor you select should not affect the system stability. As the voltage dividing resistor is generally a type that is at or above $k\Omega$ level, the impedance of the injection resistor that you select should be between 5Ω and 10Ω .

Selection of Voltage Amplitude of the Injected Interference Signal

You can attempt to try the amplitude of the injected signal from $1/20$ to $1/5$ of the output voltage.

If the voltage of the injected signal is too large, this will make the switching power supply be a nonlinear circuit, resulting in measurement distortion. If the voltage of the injected signal in the low frequency band is too small, it will cause a low signal-to-noise ratio and large interference.

Usually we tend to use a higher voltage amplitude when the injection signal frequency is low, and use a lower voltage amplitude when the injection signal frequency is higher. By selecting different voltage amplitudes in different frequency bands of the injection signal, we can obtain more accurate measurement results. MHO/DHO5000 series digital oscilloscope supports the swept signal with variable output frequencies. For details, refer to the function of the **Var.Amp.** key introduced in **Step 2 To Set the Swept Signal**.

Selection of the Frequency Band for the Injected Interference Signal

The frequency sweep range of the injection signal should be near the crossover frequency, which makes it easy to observe the phase margin and gain margin in the generated Bode plot. In general, the crossover frequency of the system is between $1/20$ and $1/5$ of the switching frequency, and the frequency band of the injection signal can be selected within this frequency range.

Experience

The switching power supply is a typical feedback control system, and it has two important indicators: system response and system stability. The system response refers to the speed required for the power supply to quickly adjust when the load changes or the input voltage changes. System stability is the ability of the system in suppressing the input interference signals of different frequencies.



The greater the phase margin, the slower the system response. The smaller the phase margin, the poorer the system stability. Similarly, if the crossing frequency is too high, the system stability will be affected; if it is too low, the system response will be slow. To balance the system response and stability, we share you the following experience:

- The crossing frequency is recommended to be 1/20 to 1/5 of the switching frequency.
- The phase margin should be greater than 45°. 45° to 80° is recommended.
- The gain margin is recommended to be greater than 10 dB.

Summary

RIGOL's MHO/DHO5000 series digital oscilloscope can generate the swept signal of the specified range by controlling the built-in signal generator module and output the signal to the switching power supply to carry out loop analysis test. The Bode plot generated from the test can display the gain and phase variations of the system under different frequencies. From the plot, you can see the phase margin, gain margin, crossover frequency, and other important parameters. The Bode plot function is easy to operate, and engineers may find it convenient in analyzing the circuit system stability.

Currently, the Bode plot function is only available for the following models of **RIGOL** oscilloscopes.

Model	 MHO5054	 MHO5104
Analog Bandwidth	500 MHz	1 GHz
No. of Analog Channels	4	4
Max. Real-time Sample Rate	4 GSa/s	4 GSa/s
Max. Memory Depth	500 Mpts	500 Mpts
Max. Waveform Capture Rate	1,000,000 wfms/s	1,000,000 wfms/s
Digital Channel	16	16
AFG Option	50 MHz, 2-CH	50 MHz, 2-CH

Boost Smart World and Technology Innovation

Industrial Intelligent
Manufacturing



Semiconductors

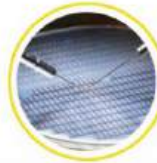

Education &
Research

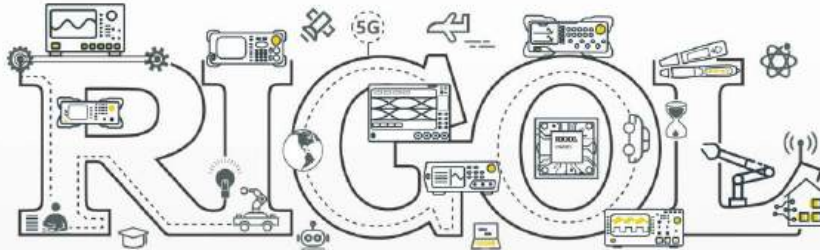

Communication



System Integration



New Energy



- 5G Cellular-5G/WIFI
- UWB/RFID/ ZIGBEE
- Digital Bus/Ethernet
- Optical Communication

- Digital/Analog/RF Chip
- Memory and MCU Chip
- Third-Generation Semiconductor
- Solar Photovoltaic Cells

- New Energy Automobile
- PV/Inverter
- Power Test
- Automotive Electronics

*Provide Testing and Measuring Products
and Solutions for Industry Customers*

HEADQUARTER

RIGOL TECHNOLOGIES CO., LTD.
No.8 Keling Road, New District,
Suzhou, JiangSu, P.R.China
Tel: +86-400620002
Email: info-cn@rigol.com

JAPAN

RIGOL JAPAN CO., LTD.
5F, 3-45-6, Minamitsuka, Toshima-Ku,
Tokyo, 170-0005, Japan
Tel: +81-3-6262-8932
Fax: +81-3-6262-8933
Email: info.jp@rigol.com

EUROPE

RIGOL TECHNOLOGIES EU GmbH
Friedrichshafener Str. 5
82205 Gilching
Germany
Tel: +49(0)8105-27292-21
Email: info-europe@rigol.com

KOREA

RIGOL KOREA CO., LTD.
5F, 222, Gonghang-daero,
Gangseo-gu, Seoul, Republic of Korea
Tel: +82-2-6953-4466
Fax: +82-2-6953-4422
Email: info.kr@rigol.com

NORTH AMERICA

RIGOL TECHNOLOGIES, USA INC.
10220 SW Nimbus Ave.
Suite K-7
Portland, OR 97223
Tel: +1-877-4-**RIGOL**-1
Email: sales@rigol.com

For Assistance in Other Countries

Email: info.int@rigol.com

RIGOL® is the trademark of **RIGOL TECHNOLOGIES CO., LTD.** Product information in this document is subject to update without notice. For the latest information about **RIGOL's** products, applications and services, please contact local **RIGOL** channel partners or access **RIGOL** official website: www.rigol.com