

Multi-Mount Continuous Monitor Installation, Operation and Maintenance



Made in the
United States of America



Figure 1. Desco 19337 Multi-Mount Continuous Monitor

Description

The Desco Multi-Mount Continuous Monitor is a single workstation continuous monitor. It continuously monitors the path-to-ground integrity of one operator and one ESD worksurface. Mounting tabs make it suitable to install in workbench or equipment settings. Connect the 19332 Light Tower accessory for increased alarm visibility.

The Multi-Mount Continuous Monitor is designed with Wave Distortion Technology which provides stable continuous monitoring of the path-to-ground and presence of 1 megohm resistance of an operator's wrist strap. Audio and visual alarms activate (in less than 50 milliseconds) when the operator unintentionally disconnects from the monitor or the wrist strap connection points are intermittent. The Multi-Mount Continuous Monitor also monitors for a worksurface path-to-ground of less than 10 megohms. All Multi-Mount Continuous Monitors are calibrated to NIST standards.

WAVE DISTORTION

Wave Distortion Technology is the Most Reliable Technology for the Continuous Monitoring of Single-Wire (Conductor) Wrist Straps

"Wave Distortion" or vector impedance works by applying a continuous test voltage of 1.2 volts peak-to-peak at 1 to 2 microamperes (0.000002 amperes) to the wrist strap that is connected to the continuous or constant monitor. The test voltage creates a square wave that the monitor circuit compares to established patterns. By monitoring the "distortions", or shape of the square wave, Wave Distortion Technology determines if the monitored circuit is complete - the operator is in the circuit and the total equivalent DC resistance is within specifications. Wave Distortion Technology produces a very fast alarm time (<50 milliseconds) and minimal false alarms.

ANSI/ESD S20.20 section 7.4 states "Compliance verification records shall be established and maintained to provide evidence of conformity to the technical requirements." Per ANSI/ESD S1.1 Annex A.3, "Daily testing may be omitted if continuous monitors are used." Per Handbook ESD TR20.20 section 11.4.4 "Typical test programs recommend that wrist straps that are used daily should be tested daily. However, if the products that are being produced are of such value that knowledge of a continuous, reliable ground is needed, then continuous monitoring should be considered or even required."

The Multi-Mount Continuous Monitor and its accessories are available as the following item numbers:

Item	Description
19337	Multi-Mount Continuous Monitor, with Universal Power Adapter
19332	Light Tower
19264	Power Adapter Extension Cord, 3'
19658	Power Adapter, 100-240 VAC Input, 9 VDC 3 A Output, IEC C14 Inlet
200220	Power Cord, Europe
200225	Power Cord, UK
98221	Wave Distortion Monitor Verification Tester

Packaging

19337 Multi-Mount Continuous Monitor

- 1 Multi-Mount Continuous Monitor
- 1 Mat Monitor Cord (White)
- 1 Countersunk Washer
- 1 Flat Head Screw, 6-32 x 1/4"
- 2 Pan-Head Screws, #6 x 3/8"
- 1 Dual Lock Fastener Set, 2" Length
- 1 10 mm Interchangeable Park Snap
- 1 10 mm Operator Jack Adapter
- 1 Power Adapter with IEC C14 Inlet, 9 VDC



Figure 2. Desco 19337 Multi-Mount Continuous Monitor packaging contents

Features and Components



Figure 3. Multi-Mount Continuous Monitor features and components

A. ParkSnap™: Allows the operator to disconnect (and park) a wrist strap when leaving the workstation, without creating a false alarm. Touch the ParkSnap™ or park delay switch, and the monitor's audible alarm will disable for approximately 8 seconds. Use this time to disconnect the wrist cord from the wristband and attach it to the ParkSnap™, or disconnect the wrist cord from the monitor. Upon returning to the workstation and disconnecting the wrist cord from the ParkSnap™, the operator has approximately 8 seconds to reconnect the wrist cord to a worn wristband before activating the alarm.

B. Monitored Operator Terminal: Connect the single-wire wrist cord here to monitor the operator's connection to ground.

C. Operator LEDs: Illuminates green when the operator is properly grounded. Illuminates solid red and audible alarm sounds when the operator is not properly grounded.

D. Mat LEDs: Illuminates green when the worksurface is properly grounded. Illuminates red and audible alarm sounds when the worksurface is not properly grounded.

E. Park Delay Switch: Allows the operator to disconnect (and park) a wrist strap when leaving the workstation, without creating a false alarm. Touch the ParkSnap™ or park delay switch, and the monitor's audible alarm will disable for approximately 8 seconds. Use this time to disconnect the wrist cord from the wristband and attach it to the ParkSnap™, or disconnect the wrist cord from the monitor. Upon returning to the workstation and disconnecting the wrist cord from the ParkSnap™, the operator has approximately 8 seconds to reconnect the wrist cord to a worn wristband before activating the alarm. The 8 second timer is indicated by the growing intensity of the monitor's blue LEDs. The blue LEDs will pulse when the operator terminal is vacant to indicate standby mode.

F. Set Switch: Toggles the monitor's settings for the audible alarm and mat monitor circuit.

Function	Procedure
Audible Alarm Volume	<ol style="list-style-type: none"> 1. Push and release the switch to toggle the buzzer's volume. 2. The volume will toggle from low, medium, and high settings.
Enable / Disable Mat Monitor Circuit	<ol style="list-style-type: none"> 1. Push and hold the switch until all LEDs illuminate green. 2. Release the switch. 3. An illuminated MAT LED indicates that the mat monitor circuit is enabled. A non-illuminated MAT LED indicates that the mat monitor circuit is disabled.

G. Light Tower Jack: Connects to the 19332 Light Tower accessory.

H. Power Jack: Connect the included 9 VDC power adapter here.

I. Monitored Mat Terminal: Verifies that the worksurface's path-to-ground is less than 10 megohms. Connect the white mat monitor cord here.

Installation

1. Remove the Multi-Mount Continuous Monitor from the box, and inspect for damage.
2. Locate an appropriate AC outlet near the Multi-Mount Continuous Monitor, and test it for proper wiring and grounding prior to use. The Desco AC Outlet Analyser or similar test equipment may be used to verify the outlet's functionality. Use item [98134](#) for UK outlets and item [98135](#) for European outlets.
3. Determine the mounting location of the Multi-Mount Continuous Monitor. Its LEDs should be visible to the operator. Secure the Full-Time Continuous Monitor to a surface using its mounting tabs and the included pan head screws or dual lock fasteners.
4. Secure the ring termination of the white mat monitor cord to the monitored mat terminal on the side of the Multi-Mount Continuous Monitor.
5. Connect the opposite end of the mat monitor cord to a grounded worksurface mat. Use the included countersunk washer and flat head screw to secure the cord to the grounded mat.
6. Connect the power adapter to the power jack located on the Multi-Mount Continuous Monitor. Plug the power adapter into the tested AC outlet.

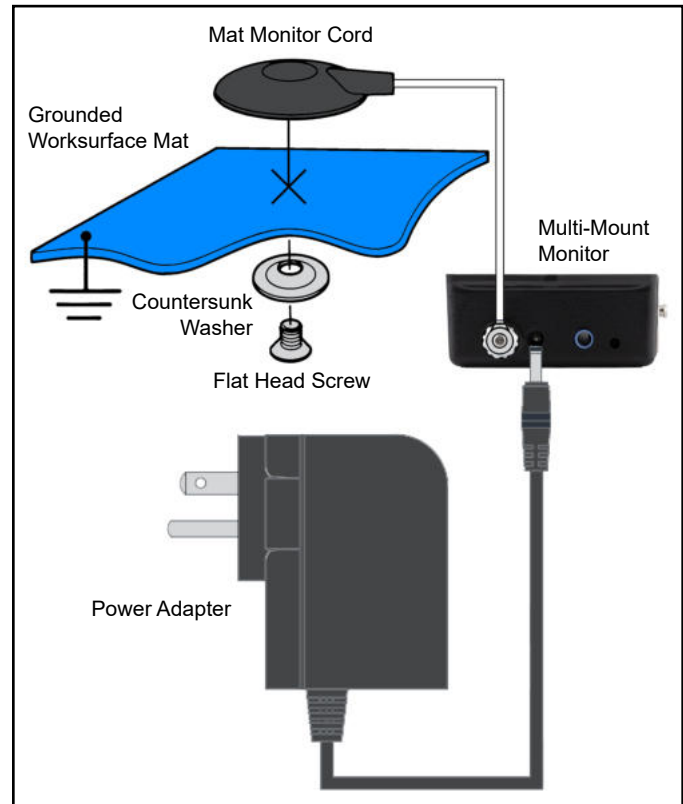

Figure 4. Installing the Multi-Mount Continuous Monitor

10 MM SNAP ADAPTERS

The 19337 Multi-Mount Continuous Monitor includes an interchangeable 10 mm ParkSnap™ and 10 mm banana jack adapter for operators who use wrist cords with 10 mm terminations. Use the ParkSnap's knurled rim to unscrew the 4 mm ParkSnap™ from the monitor and install the 10 mm ParkSnap™ to the monitor. Plug the 10 mm operator jack adapter into the monitor's operator terminal.



Figure 5. Installing the 10 mm ParkSnap™ to the 19337 Multi-Mount Continuous Monitor

Operation

1. Fit the wristband snugly onto the wrist.
2. Snap the wrist cord to the wristband.
3. Connect the wrist cord to the operator terminal. The operator LED will illuminate green. This indicates that the operator is properly grounded.
4. If this does not happen, examine the wrist cord for continuity or damage and the wristband to ensure that it fits securely. If experiencing dry skin, the operator may apply an approved dissipative hand lotion such as [Reztore® ESD Hand Lotion](#).
5. When leaving the workstation, first touch the monitor's park switch or park snap. The monitor's audible alarm will disable for approximately 8 seconds. Use this time to disconnect the wrist cord from the wristband and attach it to the park snap without sounding a false alarm.
6. Upon returning to the workstation and disconnecting the wrist cord from the park snap, the monitor will provide approximately 8 seconds for the operator to reconnect the wrist cord to a worn wristband before sounding the monitor's alarm.

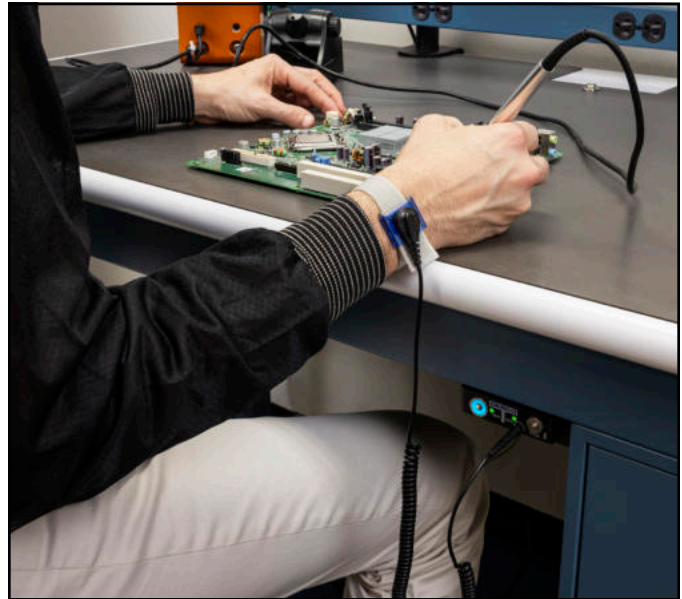

Figure 6. Using the Multi-Mount Continuous Monitor at a workbench



Figure 7. Using the ParkSnap on the Multi-Mount Continuous Monitor to store an unused wrist cord



Figure 8. Using the Multi-Mount Continuous Monitor at a machine workstation

Calibration

Frequency of recalibration should be based on the critical nature of those ESD sensitive items handled and the risk of failure for the ESD protective equipment and materials. In general, Desco recommends that calibration be performed annually.

Use the Desco 98221 Wave Distortion Monitor Verification Tester to perform periodic verification (once every 6-12 months) of the Multi-Mount Continuous Monitor. The verification tester can be used to check the test limits of the Multi-Mount Continuous Monitor without removing it from the workstation.

See [TB-3074.E](#) for more information.



Figure 9. Desco 98221 Wave Distortion Monitor Verification Tester

Specifications

Input Voltage and Frequency (External Adapter)	AC/DC Power Adapter Power Input: 100-240 VAC, 50/60 Hz Power Output: 9 VDC Cable Length: 5 ft. (1.5 m)
Operating Temperature	50 to 95° F (10 to 35° C)
Environmental Requirements	Indoor use only at altitudes less than 6500 ft. (2 km) Maximum relative humidity of 80% up to 85° F (30° C) decreasing linearly to 50% @ 85° F (30° C)
Dimensions	3.87" L x 2.09" W x .90" H (98 mm x 53 mm x 23 mm)
Weight	2.2 oz. (64 g)
Operator Test Range*	500 kilohms to 10 megohms impedance
Worksurface Test Limit**	10 megohms (±20%)
Operator Test Voltage	1.2 V peak-to-peak @ 1.2 µA, open circuit
Worksurface Test Voltage	5 to 7.5 V, open circuit
Alarm Response Time	<50 ms
Country of Origin	United States of America

*This cannot be verified with standard DC test equipment. The continuous monitor is an impedance sensing device, and the limits are determined by the magnitude and angle of the impedance.

**The worksurface mat must have a conductive layer such as Dual Layer Rubber or Dissipative 3-Layer Vinyl with conductive buried layers. Desco workstation monitors are not recommended for use with homogeneous matting.

ANSI/ESD S20.20 requires the use of a surface resistance meter for periodic verification of a worksurface's resistance-to-ground (Rtg). Constant monitors may not be used as a substitute for this requirement.

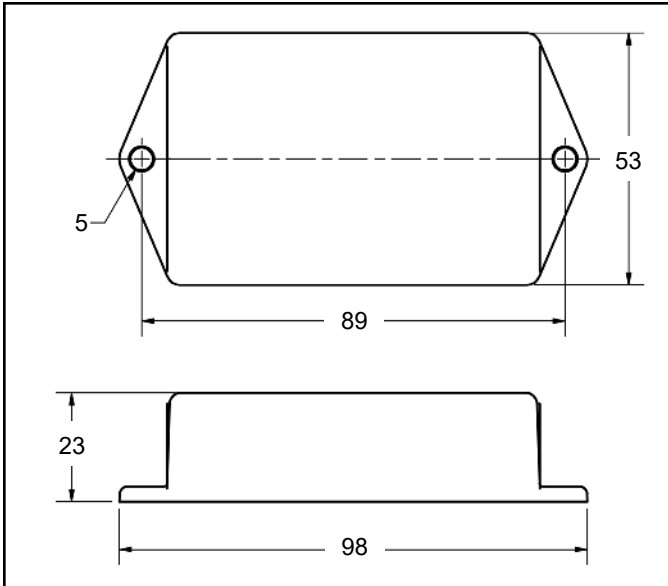

Figure 10. Mounting hole locations on the Multi-Mount Continuous Monitor (all dimensions are in mm)

Limited Warranty, Warranty Exclusions, Limit of Liability and RMA Request Instructions

See the Desco Europe Warranty - DescoEurope.com/Limited-Warranty.aspx