

Heavy Duty Dissolved Oxygen Meter

Model 407510

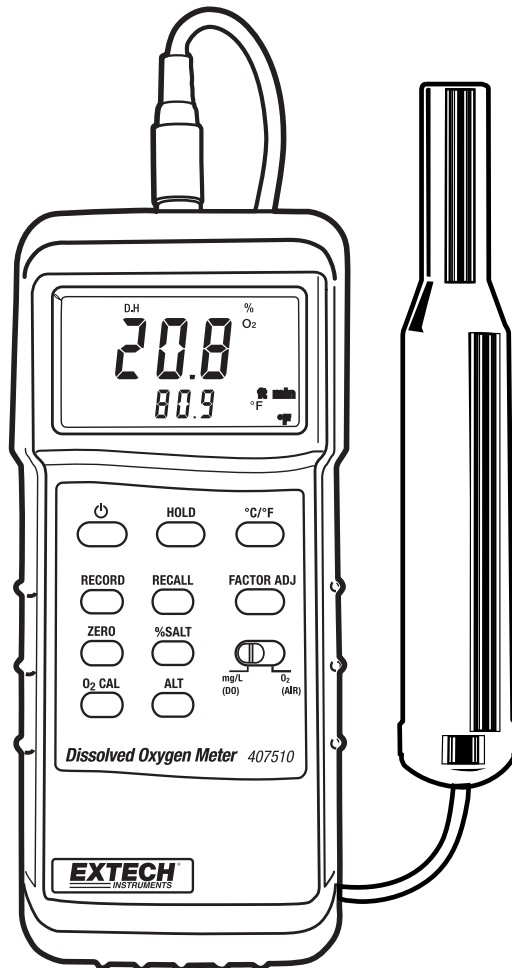

Introduction

Congratulations on your purchase of Extech's Heavy Duty Dissolved Oxygen / Temperature Meter which simultaneously displays Dissolved Oxygen or Oxygen in air, and Temperature. Units of measure are mg/l for Dissolved Oxygen, % for Oxygen in air, and °C/°F for temperature. Oxygen is measured with a remote sensor that also contains a thermistor for measuring temperature. Advanced features include RS 232 PC serial interface, data hold, auto shut off, and Min/Max/Avy recording.

Meter Description

1. LCD Display
2. POWER ON/OFF key
3. Data HOLD key
4. °C/°F selection key
5. RECORD key
6. RECALL key
7. Factor adjust key
8. Probe head
9. Sensor body
10. Sensor plug
11. RS-232 output jack
12. Battery cover (rear)
13. Altitude compensation key
14. O₂ Cal key
15. Zero key
16. Mg/L (DO), O₂ (Air) selection key
17. % Salt key

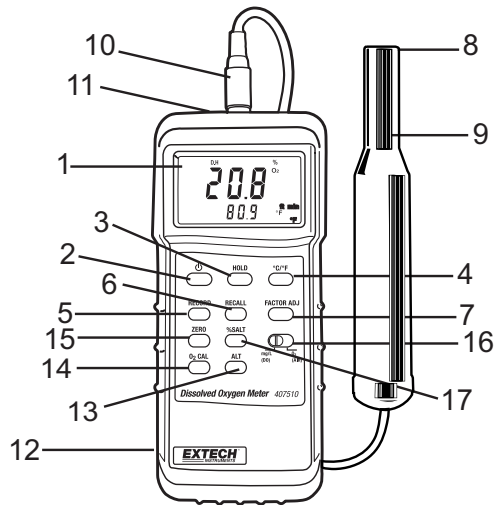

Getting Started

Note: The dissolved oxygen probe assembly may be shipped to you from the factory dry. If the probe does not contain electrolyte solution, refer to the Electrolyte Replacement section of this manual for the instructions for adding the electrolyte solution prior to initial use.

Filling the Electrolyte Container Prior to Initial Use

1. Unscrew and remove the electrolyte container from the tip of the probe.
2. Fill the electrolyte container with new electrolyte.
3. Screw the electrolyte container back onto the electrode holder and probe handle. Excess Electrolyte may be forced out through the threads. Wipe clean.
4. Lightly tap the probe to remove any air bubbles.

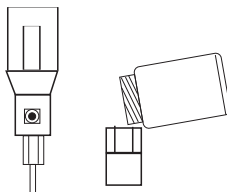

Calibration

For first time use or after long periods (several days) of non-use, calibrate the instrument using the following steps. The procedure should be performed in an open, well-ventilated area.

1. Make sure that the meter is powered OFF.
2. Ensure that the sensor is DISCONNECTED from the meter.
3. Turn ON the meter.
4. Slide the O₂/DO selector to the O₂ position.
5. Press the ZERO key to null the meter (the display should indicate "OO").
6. Turn OFF the meter.
7. Connect the DO sensor to the top of the meter (remove the plastic probe head protective cap).
8. Turn ON the meter.
9. Allow the meter to stand for at least five minutes until the most stable value is displayed.
10. Press the O₂ Cal key and the display will indicate approximately 20.9 (typical O₂ in air).

Dissolved Oxygen (DO) Measurements

Measurement Preparation

Before taking measurements, perform the calibration described above if necessary. In addition, perform the % SALT and ALTITUDE compensation adjustments as described below:

% SALT Compensation

Slide the O₂/DO switch to the DO position. If the measured liquid is pure water or is known **not** to have a salt content, set the % Salt factor to 0%.

1. Press the % Salt key. The display will indicate **0%** on the middle portion of the LCD display and **S** on the bottom portion of the LCD.
2. Pressing the Factor Adj. key once will add 1% to the salt factor.
3. Press the Factor Adj. key until the correct factor is displayed.
4. Press the % Salt key to store the factor.

ALTITUDE Compensation

The meter has a default calibration for sea level operation (0 meters). Any significant deviation from sea level requires a compensation adjustment. Perform the following steps to do so:

1. Press the ALTITUDE key and the display will indicate a "0" in the middle of the LCD and an "H" on the lower portion of the LCD.
2. Press the Factor Adj. key once to add 100 meters, twice to add 200 meters, and so on. Maximum compensation is 3900 meters.
3. Once the desired compensation is displayed, press the ALTITUDE key again to store the value.

Taking Measurements

1. Immerse the probe in the solution under test. For best automatic temperature compensation, immerse the probe to a depth of at least 4" (10 cm).
2. Wait until the display stabilizes.
3. The velocity of the liquid coming into contact with the probe must be at least 40 to 60 ft/min (0.2 to 0.3 m/s). If the solution is standing, stir the solution with the probe or use an agitator.
4. Rinse the probe with clean water after each use.

Oxygen in Air (O₂) Measurements

Follow the same steps above for DO measurements except for the variations described below:

1. Slide the O₂/DO switch to the O₂ position.
2. The display will indicate the oxygen air value in %.

Temperature Measurements

The lower display will indicate the temperature of the measured solution. Press the °C/°F key to change the temperature units.

Advanced Features

Data Hold

Press the Data Hold key to freeze the displayed value. The LCD will display **DH** for Data Hold mode along with the held reading. Press the Hold key again to release the data hold function.

MIN/MAX/AVG Data Recording

When selected, the Data Recording function records the Min, Max, and Average readings. To start a data recording session:

1. Press the RECORD key once. The REC indicator will appear on the display and the meter will begin to record the lowest (min), highest (max), and average (avg) readings.
2. To recall the data, press the RECALL key once. The MAX indicator will appear along with the highest reading recorded since the RECORD key was pressed.
3. Press the RECALL key again to view the MIN value.
4. Press the RECALL key again to view the AVG reading.
5. To exit the Record mode, press the RECORD key again. The display indicators REC, MIN, MAX, and AVG will disappear.

Auto Power OFF

The meter includes an Auto shut off feature that preserves battery life. The meter will automatically turn off if no function button is pressed in any 10 minute period. To disable this feature press the RECORD key to engage the record function.

LCD Contrast Adjust

It may be necessary to adjust the display contrast due to a change in viewing angle or voltage drift. Use the LCD Contrast adjustment located on the right side of the meter to set the preferred contrast.

CPU Reset

Certain improper keystroke sequences can cause the meter to “hang” and become inoperable. The following procedure will reset the meter.

1. Slide the O₂/DO switch to the O₂ position.
2. Turn the meter OFF and disconnect the DO probe.
3. Press and HOLD the O₂ CAL key and then press the POWER key.
4. Release the O₂ CAL key and then press the ZERO key.
5. Connect the DO probe.
6. Wait several minutes for the reading to stabilize and then press the O₂ CAL key.

RS-232 PC Interface

The meter includes a RS-232 serial data port. For streaming of data to a PC via the RS232 Output jack, the optional 407001-USB kit (RS232 to USB cable and driver CD) along with the 407001 software (available free at www.extech.com) are required.

Probe Storage

For short term storage, the probe should be stored in a moist environment to keep the membrane from drying out and needing replacement. Moisten the sponge with distilled water in the protective cap. Do not store it directly in the water since that could encourage algae growth on the probe.

Probe Head Replacement

The probe head on the tip of the probe holds a thin Teflon® membrane and an electrolyte container. Calibration or reading errors could indicate loss of electrolyte or a dirty/damaged membrane. The membrane is very delicate and can easily be damaged if it comes in contact with solid objects. Replacement probe heads are available from your local distributor.

Replacement procedure

1. Unscrew the probe head and electrolyte container from the probe handle and discard.
2. Fill the new probe head/electrolyte container with electrolyte.
3. Screw the probe head onto the probe handle. Excess electrolyte may be forced out through the threads. Wipe clean.
4. Lightly tap the probe to remove any air bubbles.

1. Probe handle
2. Temperature sensor
3. Probe Head

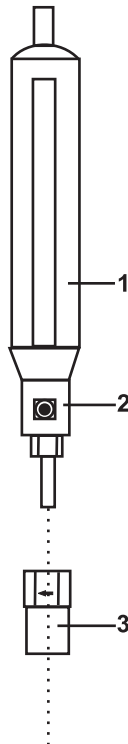

Battery Replacement

The low battery indication LBT appears on the LCD when the battery runs low.

To replace the battery:

1. Remove the meter's rubber protective cover to access the rear battery compartment.
2. Remove the battery compartment cover using a small coin or screwdriver and remove the 9V battery.
3. Replace the 9V battery and reinstall the cover and holster.



You, as the end user, are legally bound (**Battery ordinance**) to return all used batteries and accumulators; **disposal in the household garbage is prohibited!**

You can hand over your used batteries / accumulators at collection points in your community or wherever batteries / accumulators are sold!

Disposal: Follow the valid legal stipulations in respect of the disposal of the device at the end of its lifecycle

Specifications

General Specifications

Circuit	Custom one-chip LSI microprocessor circuit
Display	Dual function 13 mm (0.5") 1999 count LCD w/ contrast adjust
Measurements	Dissolved O ₂ : mg/l (milligrams per liter); Oxygen in air: %; Temperature: °C/°F
Data hold	Data hold key freezes displayed reading
Sensor Structure	Remote Polarographic Dissolved Oxygen Sensor Temperature sensor: Precision thermistor
Data recording	Min/Max/Avg readings stored for later recall
Auto power off	Meter turns off after 10 minutes
Sample rate	0.4 Sec (approx.)
Data Output	RS 232 PC serial interface
Operating conditions	Temperature: 0 to 50 °C (32 to 122 °F); Humidity: < 80% RH
Battery power	9V alkaline battery
Power Consumption	Approx. 6.6 mA DC
Weight	335 g / 0.74 lbs.(including batteries & probe)
Dimensions	Main instrument: 180 x 72 x 32mm (7.1 x 2.8 x1.3") Probe: 190x28mm (7.5" x 1.1") length/diameter
Accessories	Carrying case, 9V battery, and 5 membranes
Optional accessories	Membranes, data acquisition software & RS232 interface cable

Electrical Specifications

Measurement	Range	Resolution	Accuracy
Dissolved Oxygen	0.0 - 19.9 mg/L	0.1mg/L	± 0.4 mg/L
Oxygen in air	0 - 100% O ₂	0.1 % O ₂	± 0.7% O ₂
Temperature (probe only)	32 to 122 °F 0 to 50 °C	0.1°F/C	±1.5 °F ± 0.8 °C
Compensation adjustments	Temperature (automatic)	0 to 50°C (32 to 122 °F)	
	Salt	0 to 39%	
	Altitude	0 to 3900 meters	

Copyright © 2014-2015 FLIR Systems, Inc.

All rights reserved including the right of reproduction in whole or in part in any form.

www.extech.com