



USER MANUAL

True RMS AC/DC

2000A Utility

Clamp Meter

Model CM94

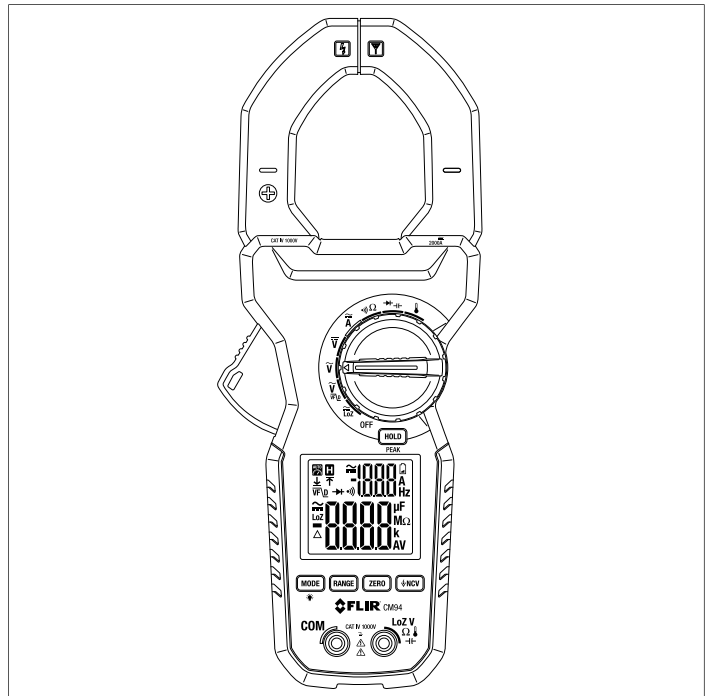



USER MANUAL

True RMS AC/DC 2000A

Utility Clamp Meter

Table of contents

1	Advisories	1
	1.1 Copyright.....	1
	1.2 Quality Assurance	1
	1.3 Documentation	1
	1.4 Disposal of Electronic Waste	1
2	Introduction	2
3	Safety	3
	3.1 General Safety Information	3
	3.2 Safety Terms Used In This Manual	3
	3.3 Warning and Caution Statements	3
	3.4 International Electrical Symbols	5
	3.5 CENELEC Directives.....	5
4	Descriptions	6
	4.1 Product Description.....	6
	4.2 Control Button Descriptions	7
	4.3 Rotary Switch Positions.....	7
	4.4 Display Description	8
5	Meter Operation	9
	5.1 Powering the Meter	9
	5.2 Auto Power OFF (APO).....	9
	5.3 Automatic and Manual Ranges	9
	5.4 Out-of-Range Alert.....	10
	5.5 Display Hold Function.....	10
	5.6 Display Backlight	10
	5.7 AC and DC Voltage Measurements.....	10
	5.8 LoZ Voltage Measurements	12
	5.9 Low Pass Filter (VFD) AC Voltage Measurements	12
	5.10 Current Clamp Measurements.....	13
	5.11 Resistance Measurements	14
	5.12 Continuity Measurements.....	15
	5.13 Diode Measurements	16
	5.14 Capacitance Measurements	18
	5.15 Type-K Thermocouple Measurements.....	19
	5.16 Non-Contact AC Voltage Detector	20
6	Maintenance	22
	6.1 Cleaning.....	22

Table of contents

6.2	Battery Replacement.....	22
6.3	Meter Storage.....	22
7	Specifications.....	23
7.1	General Specifications.....	23
7.2	DC Voltage Specifications.....	24
7.3	LoZ (DC Voltage) Specifications.....	24
7.4	AC Voltage Specifications.....	24
7.5	LoZ (AC Voltage) Specifications.....	25
7.6	VFD (low pass filter) AC Voltage Specifications.....	25
7.7	PEAK HOLD Capture Mode Specifications.....	25
7.8	Resistance Specifications.....	25
7.9	Continuity Specifications.....	25
7.10	Capacitance Specifications.....	26
7.11	Diode Specifications.....	26
7.12	DC Current Specifications (Clamp).....	26
7.13	AC Current Specifications (Clamp).....	26
7.14	Hz Line Level Frequency Specifications.....	27
7.15	Temperature Specifications.....	27
7.16	Non-Contact AC Voltage Detector (NCV).....	28
7.17	Input Specifications.....	28
7.18	Safety Specifications.....	28
8	Three-Year Warranty.....	29
9	Customer Support.....	30
9.1	Corporate Headquarters.....	30

1 Advisories

1.1 Copyright

©2021, FLIR Systems, Inc. All rights reserved worldwide. No parts of the software including source code may be reproduced, transmitted, transcribed or translated into any language or computer language in any form or by any means, electronic, magnetic, optical, manual or otherwise, without the prior written permission of FLIR Systems.

The documentation must not, in whole or part, be copied, photocopied, reproduced, translated or transmitted to any electronic medium or machine-readable form without prior consent, in writing, from FLIR Systems. Names and marks appearing on the products herein are either registered trademarks or trademarks of FLIR Systems and/or its subsidiaries. All other trademarks, trade names or company names referenced herein are used for identification only and are the property of their respective owners.

1.2 Quality Assurance

The Quality Management System under which these products are developed and manufactured has been certified in accordance with the ISO 9001 standard.

FLIR Systems is committed to a policy of continuous development; therefore, we reserve the right to make changes and improvements on any of the products without prior notice.

1.3 Documentation

To access the latest manuals and notifications, go to the Download tab at: <https://support.flir.com>. It only takes a few minutes to register online. In the download area you will also find the latest releases of manuals for our other products, as well as manuals for our historical and obsolete products.

1.4 Disposal of Electronic Waste



As with most electronic products, this equipment must be disposed of in an environmentally friendly way, and in accordance with existing regulations for electronic waste. Please contact your FLIR Systems representative for more details.

2 Introduction

The CM94 is a high accuracy, rugged measurement instrument intended for the electrical utility and industrial maintenance professional for inspecting and troubleshooting high voltage/current electrical infrastructure systems and equipment. The low input impedance mode (*LoZ*) helps determine whether a measured voltage is 'real' or induced by load carrying cables running adjacent and parallel to the measurement target (ghost voltage).

Visit <https://www.support.flir.com/prodreg> to register your CM94 and to read the three-year warranty text.

Features

- Primary 6000 count and secondary 1999 count dual backlit displays
- Dual display of ACA + Hz and ACV + Hz
- Rated CAT IV 1000V / 2000A
- True RMS sensing
- *VFD-V* and *VFD-Hz* for use with variable speed drives
- Non-contact voltage detection (*NCV*)
- PEAK mode captures Peak Min and Peak Max current/voltage in 5 millisecond window
- Data Hold and Relative/Zero modes
- Auto Power OFF (APO) in 34 minutes
- *LoZ* mode to help detect 'ghost' voltages
- Type-K thermocouple temperature measurements
- Large jaws accommodate 2.2 in. (55 mm) cables

3 Safety

3.1 General Safety Information

This user manual contains information and warnings that must be followed for operating the instrument safely and maintaining the instrument in a safe operating condition. If the instrument is used in a manner not specified by the manufacturer, the protection provided by the instrument may be impaired.

The meter protection rating, against the users, is double insulation per UL/IEC/EN61010-1 Ed. 3.0, IEC/EN61010-2-033 Ed. 1.0, CAN/CSA C22.2 No. 61010-1 Ed. 3.0, IEC/EN61010-2-032 Ed. 3.0 & IEC/EN61010-031 Ed. 1.1: Measurement Category IV 1000V AC & DC.

Per IEC61010-1 OVERVOLTAGE CATEGORY

OVERVOLTAGE CATEGORY II (CAT II) is for equipment intended to be supplied from the building wiring. It applies both to plug-connected equipment and to PERMANENTLY CONNECTED EQUIPMENT.

OVERVOLTAGE CATEGORY III (CAT III) is for equipment intended to form part of a building wiring installation. Such equipment includes socket outlets, fuse panels, and some MAINS installation control equipment.

OVERVOLTAGE CATEGORY IV (CAT IV) is for equipment installed at or near the origin of the electrical supply to a building, between the building entrance and the main distribution board. Such equipment may include electricity tariff meters and primary over-current protection devices.

3.2 Safety Terms Used In This Manual

WARNING: Identifies conditions and actions that could result in serious injury or even death to the user.

CAUTION: Identifies conditions and actions that could cause damage or malfunction in the instrument.

3.3 Warning and Caution Statements

	WARNING
To reduce the risk of fire or electric shock, do not expose this product to rain or moisture. The meter is intended only for indoor use.	

**WARNING**

To avoid electrical shock hazard, observe the proper safety precautions when working with voltages above 60 VDC or 30 VAC rms. These voltage levels pose a potential shock hazard to the user. Before and after hazardous voltage measurements, test the voltage function on a known source such as line voltage to determine proper meter functioning.

**WARNING**

Keep hands/fingers behind the hand/finger barriers (of the meter and the test leads) during measurement. Inspect test leads, connectors, and probes for damaged insulation or exposed metal before using the instrument. If any defects are found, replace them immediately. Use only the test leads provided with the equipment (or UL Listed probe assemblies rated CAT IV 1000V or better).

**WARNING**

The accompanied test probe assembly meets UL/IEC/EN61010-031 Ed. 1.1 to the same meter ratings or better. IEC 61010-031 requires exposed conductive test probe tips to be $\leq 4\text{mm}$ for CAT III & CAT IV ratings. Refer to the category markings on your probe assemblies as well as on the add-on accessories (detachable Caps or Alligator Clips, etc.), if any, for applicable rating changes.

**WARNING**

This Clamp meter is designed for clamping around or removing from non-insulated, hazardous live conductors. Nonetheless, individual protective equipment must be used when hazardous live parts in the installation, where the measurement is to be made, could be accessible.

**WARNING**

Remove test leads from the meter before taking clamp measurements.

**CAUTION**

Disconnect the test leads from the test points before changing meter functions.

**CAUTION**

Do not use the device for a procedure that it is not intended for. This can cause damage to the protection built into the instrument.

3.4 International Electrical Symbols

 Caution! Refer to the explanation in the user manual.

 Caution! Risk of electrical shock.

 Earth ground.

 Double/reinforced insulation.

 Fuse.

 AC (alternating current).

 DC (direct current).

 Application around, and removal from, hazardous live conductors is permitted.

3.5 CENELEC Directives

This instrument conforms to CENELEC Low-voltage directive 2014/35/EC, Electromagnetic compatibility directive 2014/30/EU and RoHS directive 2011/65/EU.

4 Descriptions

4.1 Product Description

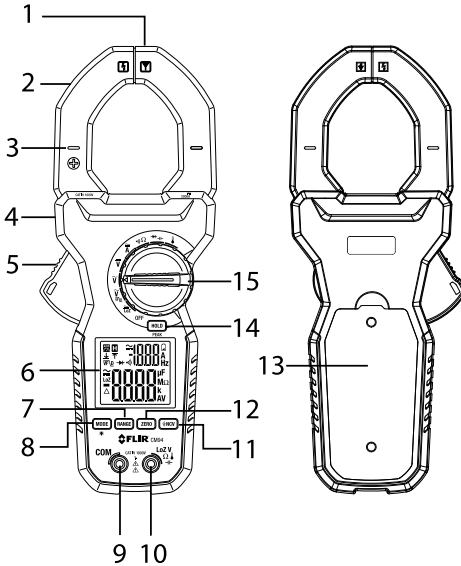













Figure 4.1 Product Description

1. Non-Contact Voltage Detector (NCV) antenna
2. Clamp jaws
3. Conductor alignment icon
4. Hand/finger barrier
5. Jaw opening trigger
6. Display
7. RANGE button
8. MODE /Display backlight button
9. Negative (COM) input terminal
10. Positive input terminal
11. Non-Contact Voltage detector button
12. ZERO /Relative mode button
13. Battery compartment
14. HOLD /PEAK button
15. Rotary selector switch

4.2 Control Button Descriptions

MODE	Short press to toggle AC/DC where necessary, to select an option at a multi-option rotary switch position, and to toggle °C and °F units in temperature measurement mode.
	Long press to toggle the display backlight ON/OFF.
RANGE	Short press to change to Manual range mode, subsequent presses will step through available ranges. Long press to return to the Auto range mode.
ZERO	Short press to engage the Relative mode where subsequent measurements are displayed relative to the measurement on the display at the time of the button press (the delta relative icon appears when the Relative mode is engaged). Long press to zero the display before taking a DC measurement.
	Short press to engage/disengage the Non-Contact Voltage Detection mode.
HOLD	Short press to freeze/unfreeze displayed readings.
PEAK	Long press to engage the PEAK mode. Short press to toggle between MAX (up arrow icon appears) and MIN (down arrow icon appears). Long press to exit the PEAK mode.

4.3 Rotary Switch Positions

OFF	Meter power is switched OFF.
	Low Impedance mode.
	AC Voltage mode with VFD (low pass filter).
	AC Voltage mode.
	DC Voltage mode.
	Current mode (AC/DC).
	Continuity mode.
	Resistance mode.
	Diode mode.
	Capacitance mode.
	Thermocouple temperature measurement mode.

4.4 Display Description

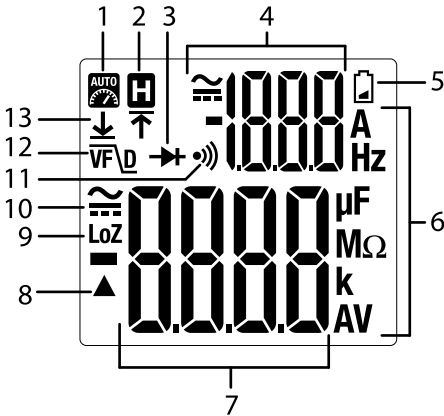

Figure 4.2 Display Description

1. Auto Range
2. Data hold
3. Diode mode
4. 1999 count secondary display
5. Battery status
6. Units of measure
7. 6000 count primary display
8. Relative mode
9. Low impedance mode
10. AC and DC measurement symbols
11. Continuity function
12. Low pass filter mode (*VFD*)
13. Peak MAX (up arrow) and Peak MIN (down arrow)

5 Meter Operation

NOTE

Before operating the device, you must read, understand, and follow all instructions, dangers, warnings, cautions, and notes.

NOTE

When the meter is not in use, the function switch should be set to the OFF position.

NOTE

When connecting the probe leads to the device under test, connect the negative lead before connecting the positive lead. When removing the probe leads, remove the positive lead before removing the negative lead.

NOTE

Before and after hazardous voltage measurements, test the voltage function on a known source (such as line voltage) to determine proper meter functionality.

5.1 Powering the Meter

Set the function switch to any position to power the meter ON.

If the low battery voltage warning is displayed, or if the meter does not power ON, replace the batteries. See Section 6, *Maintenance*, for battery replacement details.

5.2 Auto Power OFF (APO)

The APO feature switches the meter OFF after approximately 34 minutes of inactivity. The meter will beep to alert you when it is about to power OFF, press the *MODE* button to extend the APO time. If the meter powers OFF, turn the rotary switch to the OFF position first and then to an operational position to switch back ON.

5.3 Automatic and Manual Ranges

The meter uses automatic ranging by default. To manually select a measurement range, short press the *RANGE* button to exit the Auto mode. Subsequent, short presses will step through the available ranges. Long press the *RANGE* button to return to the Auto Range mode. When the Auto Range mode is active, the Auto Range symbol is displayed.



Figure 5.1 Auto Range Display Icon

5.4 Out-of-Range Alert

If the input is out-of-range, **OL** is displayed. Please do not attempt to make measurements beyond the specified ranges of the meter.

5.5 Display Hold Function

After taking a measurement, short press the *HOLD* button to freeze a reading. Press the *HOLD* button again to return to normal operation. The **H** icon will appear when the display hold function is engaged.

5.6 Display Backlight

Long press the backlight button  to turn ON the display backlighting. Long press again to switch the backlight OFF. The backlight switches OFF automatically after approximately 25 seconds to conserve battery energy.

5.7 AC and DC Voltage Measurements



CAUTION

Use caution when the measured voltage is greater than 30V DC or AC rms.

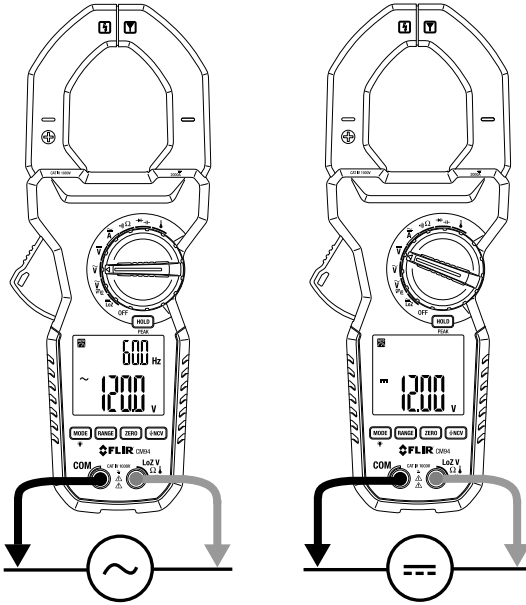

Figure 5.2 AC Voltage (left) and DC Voltage (right) Measurement Setups

1. Set the function switch to the AC Voltage \tilde{V} or DC Voltage \bar{V} position.
2. Insert the black test lead into the negative (COM) terminal and the red test lead into the positive terminal.
3. Place the probe ends of the test leads in parallel to the part under test.
4. Read the Auto Range voltage measurement on the display.
5. To switch to Manual Range mode, short press the *RANGE* button. Subsequent short presses of the *RANGE* button will step through the available ranges. Long press the *RANGE* button to return to Auto Range mode.
6. Read the frequency (Hz) of an AC signal on the upper secondary display.

5.8 LoZ Voltage Measurements



WARNING

In *LoZ* mode, the input impedance increases quickly from the initial 2.5k Ω to a few hundred k Ω 's on high voltage signals. Peak initial load current, while testing 1000 V AC for example, can be as high as 566 mA (1000 V x 1.414 / 2.5k Ω), decreasing to roughly 3.37 mA (1000 V x 1.414 / 420k Ω) within a fraction of a second. Do not use *LoZ* mode on circuits that could be damaged by such low input impedance. Use the standard high input impedance voltage modes to minimize loading on such circuits.



CAUTION

Use caution when the measured voltage is greater than 30V DC or AC rms.

LoZ Voltage measurements eliminate the affects of 'ghost' voltages. The procedure for taking *LoZ* Voltage measurements is essentially the same as for taking standard Voltage measurements, the only difference is that for *LoZ* Voltage measurements you select the *LoZ* rotary switch position and you must take into consideration the effect low impedance will have on circuitry that you test (read Warning statement above). Refer to the previous section for other Voltage measurement details.

When you turn the rotary dial to the *LoZ* position, the display will show 'auto' indicating that the CM94 will automatically detect the measured signal as AC or DC.

5.9 Low Pass Filter (VFD) AC Voltage Measurements



CAUTION

Use caution when the measured voltage is greater than 30V DC or AC rms.

Select the *VFD* mode using the rotary selector switch.

The *VFD* feature eliminates high frequency noise in AC voltage measurements by means of a low pass filter. The *VFD* mode is designed for variable frequency drive measurements. The *VFD* icon will appear on the display in this mode. The procedure for taking *VFD* Voltage measurements is identical to the procedure for taking standard Voltage measurements. Refer to the previous sections for Voltage measurement details.

5.10 Current Clamp Measurements

**WARNING**

Do not measure current on a circuit if the voltage increases to more than 1000 V. This can cause damage to the instrument and can cause injury to persons.

**WARNING**

Do not use the meter to measure current above the rated frequency. This may cause the magnetic circuits in the jaws to reach hazardous temperatures.

**WARNING**

Disconnect the test leads from the meter before taking Clamp measurements.

Clamp Measurement Considerations

- Press the jaw trigger to open the jaws and then clamp around the conductor(s) of only one pole of a circuit.
- Ensure that the jaws are completely closed. Enclosing conductor(s) of more than one pole of a circuit may result in differential current measurements.
- Align the conductor(s) to the jaws using the conductor align icons on the clamp jaws.
- Adjacent current-carrying devices such as transformers, motors and conductor wires may affect measurement accuracy.

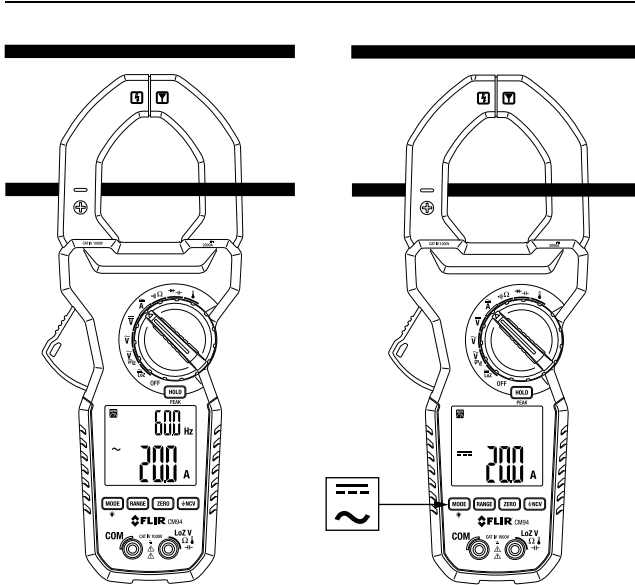

Figure 5.3 AC Current (left) and DC Current (right) Measurement Setups

Taking AC or DC Current Clamp Measurements

1. Set the function switch to the Ampere position \bar{A} .
2. Short press the *MODE* button to select AC or DC current mode.
3. For DC current mode, with no conductor in the clamp, long press the *ZERO* button to zero the display.
4. Press the trigger to open the clamp jaws and clamp around the conductor under test.
5. Read the Auto Range current measurement on the display.
6. To switch to Manual Range mode, short press the *RANGE* button. Subsequent short presses of the *RANGE* button will step through the available ranges. Long press the *RANGE* button to return to Auto Range mode.
7. Read the frequency (Hz) of an AC signal on the upper secondary display.

5.11 Resistance Measurements



WARNING

Do not perform resistance tests before removing the power to resistors and other devices under test. Injury to persons can occur.

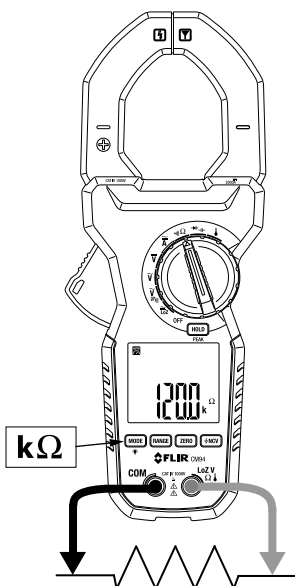



Figure 5.4 Resistance Measurement Setup.

1. Set the function switch to the Resistance Ω position.
2. If necessary, short press the *MODE* button to select the Resistance function.
3. Insert the black test lead into the negative (COM) terminal and the red test lead into the positive terminal.
4. Place the probe ends of the test leads in parallel to the part under test.
5. Read the resistance value on the display.
6. To switch to Manual Range mode, short press the *RANGE* button. Subsequent short presses of the *RANGE* button will step through the available ranges. Long press the *RANGE* button to return to Auto Range mode.

5.12 Continuity Measurements

	WARNING
Do not perform continuity tests before removing power to the device under test. Injury to persons can occur.	

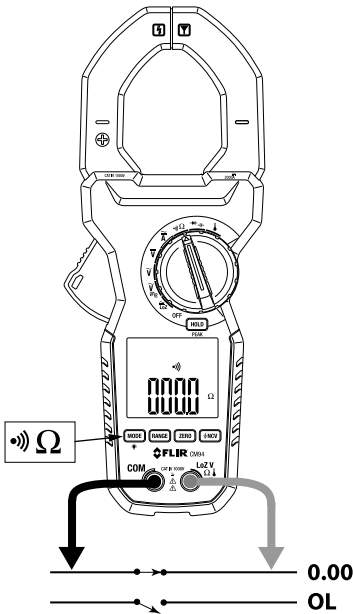

Figure 5.5 Continuity Measurements. Note the CLOSED (0.00) and OPEN (OL) circuit examples.

1. Set the function switch to the Continuity 🔔 position.
2. If necessary, short press the *MODE* button to select the Continuity function.
3. Insert the black test lead into the negative (COM) terminal and the red test lead into the positive terminal.
4. Place the probe ends of the test leads in parallel to the part under test.
5. If the measurement is $<10 \Omega$, the meter will beep. If the measurement is $> 200 \Omega$, the meter will not beep. Between 10Ω and 200Ω , the meter will stop beeping at an unspecified point.

5.13 Diode Measurements



WARNING

Do not perform diode tests before removing power to the diode under test. Injury to persons can occur.

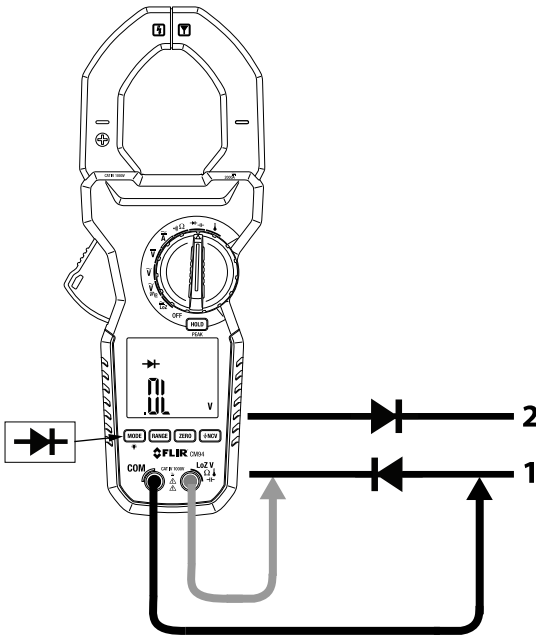



Figure 5.6 Diode Testing. Note the two test positions, forward and reverse bias.

1. Set the function switch to the Diode →+ position.
2. If necessary, short press the *MODE* button to select the Diode function.
3. Insert the black test lead into the negative (COM) terminal and the red test lead into the positive terminal.
4. Take two measurements, one forward biased and one reverse biased. This can be accomplished by, first, placing the probe ends of the test leads in parallel to the part under test in one direction and then taking a second measurement with the test leads reversed.
5. If the reading is between 0.40 V and 0.90 V in one direction and **OL** (overload) in the opposite direction, the component is good. If the measurement is 0V in both directions (shorted) or **OL** is displayed in both directions (open), the component is bad.

5.14 Capacitance Measurements

	WARNING
Do not perform capacitance tests before removing power to the capacitor under test and discharging it through an appropriate resistance load. Injury to persons can occur.	

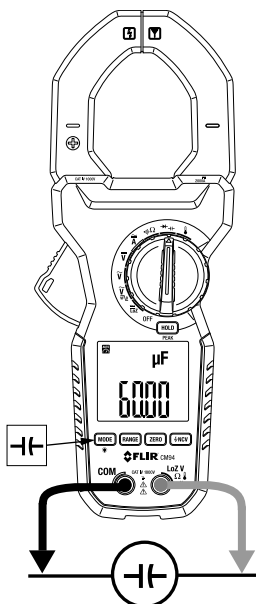



Figure 5.7 Capacitance Measurement Setup.

1. Set the function switch to the Capacitance $\text{--}\text{||}\text{--}$ position.
2. If necessary, short press the *MODE* button to select the Capacitance function.
3. Insert the black test lead into the negative (COM) terminal and the red test lead into the positive terminal.
4. Place the probe ends of the test leads in parallel to the part under test.
5. Read the capacitance value on the display.
6. To switch to Manual Range mode, short press the *RANGE* button. Subsequent short presses of the *RANGE* button will step through the available ranges. Long press the *RANGE* button to return to Auto Range mode.

5.15 Type-K Thermocouple Measurements

 **CAUTION**

The supplied thermocouple is rated for -4 ~ 482°F (-20 ~ 250°C) only, it is not rated for the entire specified temperature range of the meter.

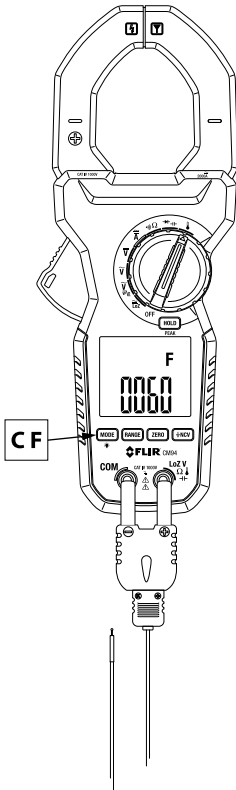



Figure 5.8 Thermocouple Temperature Measurements.

1. Set the function switch to the Temperature  position.

2. Insert the banana plug Type-K temperature probe into the meter's input terminals observing correct polarity. A plug adapter with banana plug to Type-K socket (to adapt to other Type-K standard mini plug temperature probes) can be obtained optionally.
3. Touch the thermocouple probe tip to the surface of an object under test or hold the probe in air.
4. Read the temperature measurement on the display.
5. Use the *MODE* button to toggle °C and °F units of measure.

5.16 Non-Contact AC Voltage Detector

 CAUTION
Use caution when the measured voltage is greater than 30V DC or AC rms.

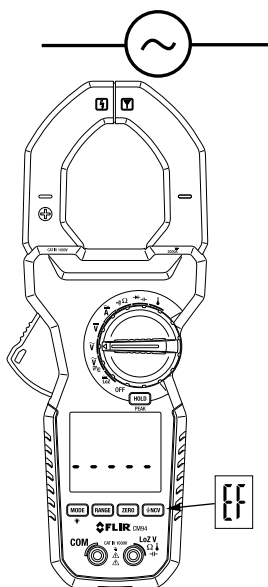

Figure 5.9 Non-Contact AC Voltage Detection (NCV).

1. Set the function switch to the AC Voltage position and remove the test leads from the CM94.
2. Short press the *NCV* button. The display will show the **EF** symbol (electromotive force).

3. The voltage detection antenna is located at the tip of the clamp jaws, just to the right of the jaw opening seam (with the meter facing you).
4. Hold the CM94 with hand/fingers behind the safety barrier and place the antenna near the source of potential voltage. Leave the jaws closed while using the voltage detector.
5. If voltage is present, the meter will beep and display dashes. The higher the voltage, the higher the beep rate and the higher the number of displayed dashes (1, 3, or 5 dashes).

6 Maintenance

6.1 Cleaning

With the CM94 OFF, wipe the meter housing with a damp cloth as needed. Do not use abrasives or solvents. Dry completely before use.

6.2 Battery Replacement

The battery compartment is located on the back of the CM94 secured by two screws. Open the compartment and replace the two 'AA' batteries observing correct polarity. Please secure the battery compartment before using the meter.

6.3 Meter Storage

If the meter is to be stored for an extended period, please remove the batteries and store separately.

7 Specifications

7.1 General Specifications

Display	Primary: 6000 count backlit LCD Secondary: 1999 count backlit LCD
Polarity	Automatic
Update rate	5 readings per second, nominal
Operating temperature	14 ~ 122°F (-10 ~ 50°C)
Relative humidity	Maximum relative humidity 80% for temperature up to 88°F (31°C) decreasing linearly to 50% relative humidity at 122°F (50°C)
Pollution	Degree 2
Storage temperature	-4 ~ 140°F (-20 ~ 60°C) < 80% RH (with battery removed)
Operating altitude	7000 ft. (2000 m) maximum
Temperature coefficient	Nominal 0.15 x (specified accuracy)/ °C @ (0 ~ 18°C [32 ~ 64.4°F] or 28 ~ 40°C [82.4 ~ 104°F]), or as otherwise specified
Sensing	True RMS
Transient protection	12 kV (1.2/50µs surge)
Overload Protection	Current Clamp measurements: 2000A DC/AC rms continuous Voltage functions (input terminals): 1100V DC/AC rms Other functions (input terminals): 1000V DC/AC rms
Power supply	1.5 V 'AA' battery x 2
Power consumption	14 mA for Current functions; 5.2 mA for other functions
Low battery	< 2.4 V, approximately
APO timer	After 34 minutes of inactivity, approximately
APO consumption	10µA, typical
Dimensions	(LxWxH): 269 x 106 x 51 mm (10.6 x 4.2 x 2.0 in.)

Weight	700 g (24.7 oz.)
Jaw opening/Conductor diameter	55 mm (2.2 in.) maximum
Electrical specification accuracy	\pm (% reading + number of digits) or as otherwise specified, at 73.4°F (23°C) \pm 9°F (5°C).
Accessories	Supplied: Test lead pair, Type-K thermocouple with banana-type connectors, printed Quick Start, and soft carrying pouch. Optional: Banana plug to Type K socket plug adaptor

7.2 DC Voltage Specifications

Range and Resolution	Accuracy
6.000 V, 60.00 V, 600.0 V, & 1000 V	\pm (0.5% + 5 digits)

Input Impedance: 10M Ω , 50 pF nominal

7.3 LoZ (DC Voltage) Specifications

Range and Resolution	Accuracy
6.000 V, 60.00 V, 600.0 V, & 1000 V	\pm (1.3% + 5 digits)

LoZ DCV threshold: > 1.5 V DC, and < -1.5 V DC

Input impedance: Initially approx. 2.5k ohms, 600pF, nominal; Impedance increases within a fraction of a second as voltage increases above 50V (typical). Final impedance vs. displayed voltage: 10k ohms @100V, 60k ohms @300V, 200k ohms @600V, 420k ohms @1000V (typical)

7.4 AC Voltage Specifications

Range and Resolution	Frequency	Accuracy
6.000 V, 60.00 V, 600.0 V, & 1000 V	50 Hz ~ 400 Hz	\pm (1.2% + 5 digits)

Input Impedance: 10M Ω , 50 pF nominal

7.5 LoZ (AC Voltage) Specifications

Range and Resolution	Frequency	Accuracy
6.000 V, 60.00 V, 600.0 V, & 1000 V	50 Hz ~ 60 Hz	± (1.5% + 5 digits)

LoZ ACV threshold: > 1.5V AC, and < -1.5V AC

Input impedance: Initially approx. 2.5k ohms, 600pF, nominal; Impedance increases within a fraction of a second as voltage increases above 50V (typical). Final impedance vs. displayed voltage: 10k ohms @100V, 60k ohms @300V, 200k ohms @600V, 420k ohms @1000V (typical)

7.6 VFD (low pass filter) AC Voltage Specifications

Range and Resolution	Frequency	Accuracy ¹
6.000 V, 60.00 V, 600.0 V, & 1000 V	10 Hz ~ 20 Hz	± (4.0% + 80 digits)
	20 Hz ~ 200 Hz	± (2.0% + 60 digits)
	200 Hz ~ 400 Hz ²	± (7.0% + 80 digits)

1. Not specified for fundamental frequency > 400 Hz

2. Accuracy linearly decreases from 2% + 60 digits @ 200 Hz to 7% + 80 digits @ 400 Hz

7.7 PEAK HOLD Capture Mode Specifications

Accuracy: Specified accuracy plus 250 digits for changes > 5ms in duration.

7.8 Resistance Specifications

Range and Resolution	Accuracy
600.0 Ω, 6.000 kΩ, 60.00 kΩ	± (0.5% + 5 digits)
600.0 kΩ	± (0.8% + 5 digits)
6.000 MΩ	± (1.2% + 5 digits)
40.00 MΩ	± (2.3% + 5 digits)

Open Circuit Voltage: 0.45 V DC, typical

7.9 Continuity Specifications

Audible threshold: 10Ω ~ 200Ω.

Beeper response time: 32ms, approx.

Beeper frequency: 2k Hz

7.10 Capacitance Specifications

Range and Resolution	Accuracy ¹
60.00 nF, 600.0 nF, 6.000 μ F	\pm (2.0% + 5 digits)
60.00 μ F, 600.0 μ F	\pm (3.5% + 5 digits) ²
2000 μ F	\pm (4.0% + 5 digits) ³

1. Accuracy specified with film capacitor or better
2. Temperature coefficient: 0.25 x (specified accuracy) / °C [1.8°F] @ (0 ~ 18°C [32 ~ 64.4°F] or 28 ~ 40°C [82.4 ~ 104°F])
3. Temperature coefficient: 0.25 x (specified accuracy) / °C [1.8°F] @ (0 ~ 18°C [32 ~ 64.4°F] or 28 ~ 40°C [82.4 ~ 104°F])

7.11 Diode Specifications

Range and Resolution	Accuracy
1.000 V	\pm (1.0 + 3 digits)

Test Current: 0.56 mA, typical

Open Circuit Voltage: < 1.8 V DC typical

7.12 DC Current Specifications (Clamp)

Range and Resolution	Accuracy ^{1 2}
200.0 A	\pm (2.0% + 5 digits)
0 ~ 500 A	\pm (2.0% + 5 digits)
500 ~ 2000 A	\pm (3.0% + 5 digits)

1. Induced error from adjacent current-carrying conductors: < 0.1 A/A
2. Accuracy specified with DC Zero (Relative) mode applied to offset non-zero residual readings

7.13 AC Current Specifications (Clamp)

Range and Resolution	Frequency	Accuracy ¹
200.0 A	50 ~ 60 Hz	\pm (2.0% + 5 digits)
0 ~ 500 A		\pm (2.5% + 5 digits)
500 ~ 2000 A		\pm (3.0% + 5 digits)

200.0 A	40 Hz ~ 50 Hz and 60 Hz~ 400 Hz	± (2.5% + 5 digits)
0 ~ 500 A		± (3.0% + 5 digits)
500 ~ 1000 A		± (3.5% + 5 digits)
1000 ~ 2000 A		Unspecified

1. Induced error from adjacent current-carrying conductors: < 0.1 A/A

True RMS crest factor < 1.4 : 1 at full scale and < 2.8 : 1 at half scale.

7.14 Hz Line Level Frequency Specifications

Range/Function	Sensitivity (sine RMS)	Frequency Range
6 V	2 V	40 Hz ~ 1999 Hz
60 V	20 V	
600 V	100 V	
1000 V	600 V	
200 A	10 A	20 Hz ~ 400 Hz
2000 A	40 A	
6 V (VFD) ¹	1 V ~ 2 V	10 Hz ~ 400 Hz
60 V (VFD) ²	6 V ~ 20 V	
600 V (VFD) ³	60 V ~ 200 V	

1. VFD sensitivity linearly decreases from 10% F.S. @ 200Hz to 40% F.S. @ 400Hz

2. VFD sensitivity linearly decreases from 10% F.S. @ 200Hz to 40% F.S. @ 400Hz

3. VFD sensitivity linearly decreases from 10% F.S. @ 200Hz to 40% F.S. @ 400Hz

Accuracy: ± (0.1% + 4 digits)

7.15 Temperature Specifications

Range ¹	Accuracy ²
-50 ~ 1000°C	± (0.3% + 4 digits)
-58 ~ 1832°F	± (0.3% + 6 digits)

1. Supplied thermocouple is rated for -4 ~ 482°F (-20 ~ 250°C) only, and therefore not rated for the entire specified temperature range of the meter.

2. Assumes meter interior and ambient temperature have reached stable isothermal stage for correct junction voltage compensation. Does not include error introduced by thermocouple probe.

7.16 Non-Contact AC Voltage Detector (NCV)

Typical Voltage	Tolerance	Bar Graph Indication
40 V	10 V ~ 90 V	1 dash (—)
100 V	64 V ~ 162 V	3 dashes (— — —)
165 V	125 V ~ 1000 V	5 dashes (— — — — —)

7.17 Input Specifications

Function	Overload Protection
Voltage, Current	1100V DC/AC RMS
Resistance, Temperature, Diode, <i>LoZ</i>	1000V DC/AC RMS

7.18 Safety Specifications

General Safety	CE/EN/UL/CSA/RCM 61010
Category ratings	CAT IV 1000V AC/DC
Environmental Safety	REACH Regulation EC 1907/2006 RoHS2 Directive 2011/65/EC WEEE Directive 2012/19/EC
Drop-proof	Designed to 6.6 ft. (2 m)
EMC	EN 61326-1:2006 (EN 55022, EN 61000-3-2, EN 61000-3-3, EN 61000-4-2, EN 61000-4-3, EN 61000-4-4, EN 61000-4-5, EN 61000-4-6, EN 61000-4-8, EN 61000-4-11)

8 Three-Year Warranty

Please register your product within 60 days of purchase. Register your product at <https://support.flir.com/prodreg> or use the QR Code. Read the warranty text at the links provided.



Figure 8.1 Product Registration QR Code

9 Customer Support

Repair, Calibration, and Technical Support: <https://support.flir.com>.

9.1 Corporate Headquarters

FLIR Systems, Inc.

27700 SW Parkway Avenue

Wilsonville, OR 97070 USA



Website

<http://www.flir.com>

Customer support

<http://support.flir.com>

Copyright

© 2021, FLIR Systems, Inc. All rights reserved worldwide.

Disclaimer

Specifications subject to change without further notice. Models and accessories subject to regional market considerations. License procedures may apply. Products described herein may be subject to US Export Regulations. Please refer to exportquestions@flir.com with any questions.

Publ. No.: NAS100019
Release: AC
Commit: 79017
Head: 79277
Language: en-US
Modified: 2021-08-30
Formatted: 2021-09-09