

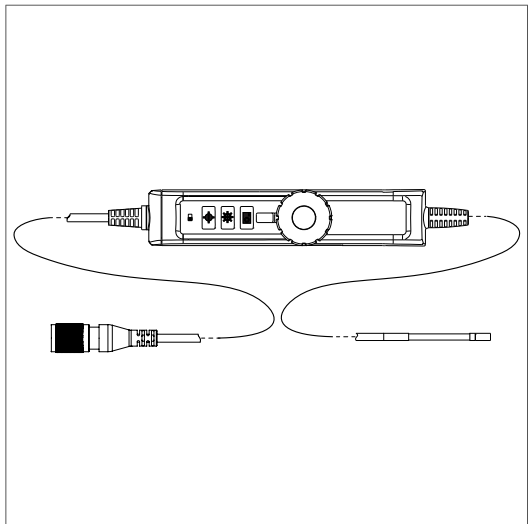

User Manual

Two-Way Articulating Camera Probe

Model VS80A2-45-1RM



Introduction

Thank you for selecting the FLIR two-way articulation probe. The probe is intended for use with the VS80 High Performance Video-scope system. Obtain the VS80 user manual and additional translations of this user manual on the support site:

<https://support.flir.com>

Description

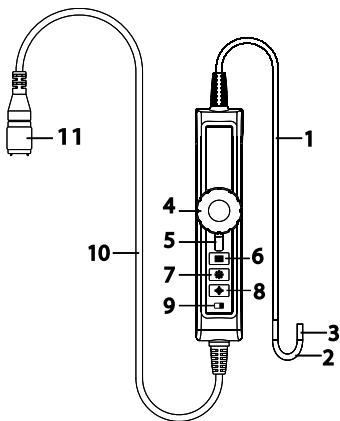

1. Probe
2. Articulating neck
3. Camera head
4. Articulation control dial
5. Slider to lock articulation
6. Image and video recording button
7. Brightness increase button
8. Brightness decrease button
9. Control button lock switch
10. Connecting cable to VS80
11. VS80 connector

Connecting the Probe

The steps below explain how to safely connect the probe to the VS80 monitor. Always turn the VS80 power off before replacing the probe.

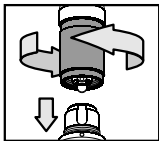

1. Align the white dot on the probe connector with the white dot on the monitor connector.
2. Plug the probe into the monitor unit, ensuring proper alignment and full insertion.
3. Tighten the collar nut to secure the connection. Do not overtighten.

Operation

Controlling Articulation

Turn the control dial (4) clockwise to bend the probe neck to the right; turn the dial counter-clockwise to bend the neck to the left, as shown in the image below. The articulation range is 180° maximum, do not attempt to force the control dial past the bend limit.



Articulation Lock

To lock the flexible neck in position, move the locking slider (5) to the right as shown in the image above. Move the slider to the left to release the lock.

Use caution when removing the probe from an inspection area; if the neck is locked at an angle, it may bind and become difficult to remove. Straighten the neck before removing the probe from the inspection area.



CAUTION



Do not use excessive force when turning the control dial, damage to the camera probe can result. Do not attempt to force the flexible neck past its maximum angle. Stop turning the control dial when the maximum angle is reached.

Image and Video Capture Button

Short press the Image and Video Capture button (6)  to capture a still image. Long press to start or stop video recording. Images and videos are stored on the VS80 micro SD card.

The VS80 user manual provides detailed information regarding media management. Obtain the user manual from the FLIR support website (see Support section below).

Brightness Control Buttons

Use the brightness controls   (7, 8) to increase and decrease the brightness of the camera images.

Control Button Lock Switch

Use the locking switch (9) to disable the three control buttons (6, 7, 8). This is useful to avoid inadvertent activation of the buttons.

Safety

Please read and understand all safety cautions before use.



CAUTION

Do not insert the probe into flammable liquid or gas.

The probe contains small circuitry that controls the optics and electronics of the camera. To ensure reliability, do not bend the probe more than 90°, and, when storing, always coil the probe in a large arc.

This product is designed for industrial use only. It is not intended for use in human or other biological inspection.

**CAUTION**

Do not disassemble the product, damage to the product and electrical shock may occur.

Use only recommended components and accessories; unapproved equipment may cause damage to the product.

Avoid direct sun exposure. Store in a cool, dry, and well-ventilated area.

To protect the camera, keep the lens cap, and other supplied protective coverings, attached when not in use. Store in the original case.

**CAUTION**

The neck, near tip of the probe, is particularly sensitive to excessive force. Never bend the neck by hand; use only the control dial. Keep the insert neck as straight as possible while in use. Never insert or bend the neck by force and never over-bend any section of the probe.

**CAUTION**

To avoid camera damage, please straighten the neck before removing it from the inspection area. Failure to do so may cause the camera to become stuck in the inspection area.

**CAUTION**

Do not coil the probe < 15 cm (6 in) in diameter in use or when storing, damage to the probe may result.

Straighten the neck angle before placing in storage.

**CAUTION**

Please keep the probe's alignment as straight as possible while in use.

Do not force the control dial when resistance to movement is felt; Damage to the camera can result.

Do not allow the probe to forcefully impact an object.

Do not put excessive weight on any area of the probe.

Never use the probe as a hammer, hook, or other tool.

Never use the probe tip to clear pathways or to unclog a pipe.

**CAUTION**

Do not allow the camera head to come in contact with acidic, corrosive or heated material, serious damage to the equipment can occur.

Before inspecting a vehicle, shut off the engine. Allow the metal and liquids in the vehicle to cool before inspection.

**CAUTION**

To clean the probe, wipe with a soft cloth dampened with a mild detergent and clean water. Do not use abrasive detergents. Do not use corrosives or solvents to clean the probe. Use a high quality lens cleaning fluid and a lint-free swab to clean the camera and worklight lenses.

Specifications

Camera resolution	640 (H) * 480 (V) pixels
Frame rate	30 frames per second (fps)
Probe diameter	3.9 mm (0.15 in)
Probe head diameter	4.5 mm (0.2 in)
Probe head length	14 mm (0.5 in)
Probe length	1 m (3.3 ft)
Articulation angle	180° maximum (the angle may decrease if the probe is looped)

Probe head material	Stainless steel
Probe body material	Braided mesh stainless steel
Worklights	Five (5) LED lamps
Field of View (FOV)	90°
Depth of Field (DOF)	1 to 10 cm (0.4 to 4.0 in)
Operating temperature	0°C to 60°C (32°F to 140°F)
Storage temperature	-10°C to 60°C (14°F to 140°F)
Liquids approved for probe submersion	Brake and transmission fluid, diesel fuel, unleaded gasoline, engine oil, and CPC hydraulic oil (46AWS)
Ingress protection	Probe tip and body: IP 67 (IEC 60529) Protected from submersion in water up to 1 meter (3.3 ft) for 30 minutes maximum. In use: rain, splashes, and accidental submersion

Warranty and Support

Three-Year Limited Warranty

This product is protected by FLIR's 3-Year Limited Warranty. Visit www.flir.com/testwarranty to read the 3-Year Limited Warranty document.

Customer Support

Customer Support Telephone List:	https://support.flir.com/contact
Repair, Calibration, and Technical Support	https://support.flir.com



User Manual

Website

<http://www.flir.com>

Customer support

<http://support.flir.com>

Copyright

© 2022, FLIR Systems, Inc. All rights reserved worldwide.

Disclaimer

Specifications subject to change without further notice. Models and accessories subject to regional market considerations. License procedures may apply.

Products described herein may be subject to US Export Regulations. Please refer to exportquestions@flir.com with any questions.

Publ. No.: NAS100102

Release: AB

Commit: 83682

Head: 84877

Language: en-US

Modified: 2022-03-05

Formatted: 2022-05-06