

ENGLISH

User manual



TABLE OF CONTENTS

1 PRECAUTIONS AND SAFETY MEASURES	2
1.1 Preliminary instructions	2
1.2 During use	3
1.3 After use	3
1.4 Definition of measurement (overvoltage) category	3
2 GENERAL DESCRIPTION	4
2.1 Instrument features	4
3 PREPARATION FOR USE	5
3.1 Initial inspections	5
3.2 Instrument power supply	5
3.3 Storage	5
4 DESCRIPTION OF PARTS	6
4.1 HT2055S station unit description	6
4.1.1 Modify of supply voltage for HT2055S unit.....	6
4.2 Description of test leads	7
4.2.1 Front view	7
4.2.2 Top view	7
4.2.3 Backside view.....	8
5 INITIAL OPERATIONS WITH HT2055M UNIT	9
5.1 Settings.....	9
5.1.1 Language selection	9
5.1.2 Help screen	9
5.1.3 Synchronization.....	10
5.1.4 Default settings.....	11
5.1.5 Time/Date settings	11
5.2 Messages at display	11
6 INITIAL OPERATIONS WITH HT2055S UNIT	12
6.1 Settings.....	12
6.1.1 Default settings.....	12
6.1.2 Setting output power	13
6.1.3 Setting alarm condition.....	13
6.2 Adjust contrast of display	14
6.3 Help screens	14
6.4 Messages at display.....	14
7 HOW TO PERFORM THE MEASUREMENTS	15
7.1 Theory of Step/Contact voltage measurements.....	15
7.2 Step/Contact voltage measurement.....	16
7.3 Earth resistance measurement	21
7.4 Ground resistivity measurement	23
8 OPERATION WITH MEMORY	25
8.1 Saving results	26
8.2 Recall result at display	26
8.3 Delete saved results.....	27
9 CONNECTION OF THE INSTRUMENT TO PC	28
9.1 Installation of software and initial configurations (Win XP)	28
10 MAINTENANCE	30
10.1 Replacement and charging batteries	30
10.2 Replacement fuses of HT2055S unit	30
10.3 Cleaning the instrument	30
10.4 End of life.....	30
11 TECHNICAL SPECIFICATIONS	31
11.1 General characteristics.....	32
11.2 Environment	33
11.3 Standard accessories.....	33
11.4 Optional accessories	33
12 SERVICE	34
12.1 Warranty conditions.....	34
12.2 Service.....	34

1 PRECAUTIONS AND SAFETY MEASURES

The instrument has been designed in compliance with standards IEC/EN61557-1 and IEC/EN61010-1 regarding electronic measuring instruments.



CAUTION

For the operator's safety and to prevent damaging the instrument, follow the procedures described in this manual and carefully read all notes preceded by the symbol .

Before and during measurements, carefully observe the following instructions:

- Do not perform any measurement in humid environments, in the presence of gas or explosive or inflammable material or in dusty areas
- Even when no measurements are being performed, avoid any contact with the circuit under test, with exposed metal parts, with unused measuring leads or circuits, etc.
- Do not perform any measurement when anomalies are found in the instrument, such as deformations, breaks, substance leaks, no display view, etc.
- During instrument operation, the ventilation holes on casing of HT2055S unit should always stay open to ensure enough air-flow for cooling
- Disconnect all test leads, switch off the instrument and remove the mains cord before changing the fuse on the HT2055S unit
- Pay special attention when measuring voltages above 25V in special environments (building yards, swimming pools, etc.) and 50V in ordinary environments, as there is danger of electric shocks.

In this manual and on the instrument, the following symbols are used:



WARNING: Observe the instructions reported in the manual. An improper use could damage the instrument and lead to dangerous situations for the operator.



AC voltage or current.



Instrument with double insulation.

1.1 PRELIMINARY INSTRUCTIONS

- This instrument (HT2055M) has been designed for use in an environment with pollution level 2
- It may also be used to test industrial electrical systems up to CAT II 300V and CAT IV 50V to earth (HT2055S) and CAT IV 50V (HT2055M)
- Follow the usual safety rules to protect the operator from dangerous currents and protect the instrument against improper use
- Never use the instrument standing on the floor, it must be placed on flat horizontal surfaces
- Only the accessories supplied with the instrument guarantee safety standards. They must be in good conditions and replaced, if necessary, with identical models
- Do not measure systems exceeding the current and voltage limit values specified
- Do not perform measurements under environmental conditions out of the limit values indicated in this manual
- Before connecting the probes to the circuit under test, check that the correct function is selected

1.2 DURING USE

Carefully read the following recommendations and instructions:



CAUTION

Failure to observe the warnings and/or instructions may damage the instrument and/or its components or generate a danger for the operator

- Before selecting a new function, disconnect the measuring probes from the circuit
- When the instrument is connected to the circuit under test, never touch any unused lead
- The auxiliary current probe can be subject to a higher voltage. Avoid the contact with this probe during measurement
- Avoid measuring resistance with external voltages. Even if the instrument is protected, as an excess voltage may cause instrument malfunctions

1.3 AFTER USE

When measurements are completed, turn off the instrument by pressing the ON/OFF key.

1.4 DEFINITION OF MEASUREMENT (OVERVOLTAGE) CATEGORY

Standard "IEC/EN61010-1: Safety requirements for electrical equipment for measurement, control and laboratory use, Part 1: General requirements", defines what is intended for measurement category, commonly known as overvoltage category. In § 6.7.4: Measuring circuits, it reads:

Circuits are divided into the following measurement categories:

- **Measurement category IV** is for measurements performed at the source of a low-voltage installation.
Examples are electric counters and measurements on primary devices protecting against overcurrents and on ripple adjusting units.
- **Measurement category III** is for measurements performed on installations inside buildings.
Examples are measurements performed on distribution boards, circuit breakers, wiring harnesses, including cables, bars, junction boxes, switches, sockets of fixed installations and appliances designed for industrial use and other equipment, e.g. stationary motors connected to fixed systems.
- **Measurement category II** is for measurements performed on circuits directly connected to the low-voltage installation.
Examples are measurements performed on household appliances, portable tools and similar equipment.
- **Measurement category I** is for measurements performed on circuits not directly connected to the MAINS.
Examples are measurements performed on circuits not derived from the MAINS and on circuits derived from the MAINS provided with a special (internal) protection. In this latter case, the stress caused by the transients is variable; therefore, (OMISSIS) it is necessary that the user knows the appliance's resistance to transients.

2 GENERAL DESCRIPTION

The instrument HT2055 you purchased grants accurate and reliable measurements as well as the utmost safety provided it is used in compliance with the indications given in this manual. Thanks to a new concept development it ensures double insulation and, consequently, compliance with the requirements of overvoltage category IV.

The instrument is composed of the following two units:

HT2055S → Station unit which can generate the test current in order to perform the step/contact voltage and the earth/resistivity measurements

HT2055M → Meter unit in order to perform the step/contact voltage measurements with test current generated by the station unit.

2.1 INSTRUMENT FEATURES

- Step/contact voltage measurement with test current of max 55A
- Earth resistance measurement with 4 wire method
- Ground resistivity measurement with Wenner method
- Use of metal plates for step/contact voltage measurement
- Initial synchronizing for autonomous use of the meter unit
- DSP internal filtering for compensation of disturbance effect on the measurement
- Internal memory for saving test
- USB interface for data transfer to PC
- Use of rechargeable batteries on meter unit

A dot matrix LCD offers easy-to-read results and all associated parameters. The operation is straightforward and clear to enable the user to operate the instrument without the need for special training (except reading and understanding this user manual).

Test results can be stored on the instrument. The new professional PC SW enables straightforward transfer of test results and other parameters in both directions between the test instrument and PC

3 PREPARATION FOR USE

3.1 INITIAL INSPECTIONS

Before shipment, the instrument's electronics and mechanics were inspected. All possible precautions were taken to permit delivery of instrument free of damage. However, we recommend generally inspecting the instrument in order to detect any damage suffered during transport. Should you detect any anomalies, immediately contact the forwarding agent or the dealer. Moreover, we recommend checking that the package contains all parts listed in § 11.3. Should you find any discrepancy, please contact the dealer. Should it be necessary to return the instrument, please follow the instructions reported in § 12.

3.2 INSTRUMENT POWER SUPPLY

The station unit HT2055S is power-supplied by 230V \pm 10%, 50/60Hz mains while the meter unit HT2055M is power-supplied through 6x1.2V IEC AA internal rechargeable batteries which are recharged from the mains by means of a battery charger supplied as standard accessory. The use of 6x1.5V type AA LR6 alkaline batteries is also possible for this unit. The symbol "" indicates that the batteries are low and must be recharged. To recharge or replace the batteries, follow the instructions given in § 10.1

CAUTION



- **Use NiMh rechargeable batteries IEC LR6 all of the same type for the HT2055M unit**
- **Do not charge alkaline battery cells**
- At the first use of HT2055M unit connect the instrument to the mains power supply for at least **14 hours** to fully charge batteries. When you charge the batteries for the first time, it normally takes about 4 charge and discharge cycles for the batteries to regain full capacity

3.3 STORAGE

In order to guarantee accurate measurements and protect the instrument from possible failures, after a long storage period under extreme environmental conditions, wait for the instrument to return to a normal condition (see the environmental specifications listed in § 11.2).

4 DESCRIPTION OF PARTS

4.1 HT2055S STATION UNIT DESCRIPTION



Fig. 1: HT2055S unit description

CAPTION:

1	Protection fuse on mains (see § 11.1)
2	Switch for supply voltage selection (110/230V)
3	ON/OFF key to switch the instrument ON or OFF
4	Input connector for mains cord
5	RS-232 galvanic port for connection to HT2055M unit
6	C1/H terminal for connection of auxiliary earth probe
7	P1/S for connection of auxiliary voltage probe
8	P2/ES for connection of auxiliary current probe
9	C2/E for connection of auxiliary earth probe
10	HELP key
11 – 12	◀ and ▶ keys for function selection and parameter settings
13	LCD display with backlit
14	Key for adjust contrast of display
15	MEM key for access to internal memory (see § 8)
16	ESC key to return at previous screen
17	◀, ▲, ▶, ▼ arrow keys and TEST key to activation measurements

4.1.1 Modify of supply voltage for HT2055S unit

1. Open the fuses compartment (see Fig. 1 – Part 1) with a screwdriver
2. Extract the red switch (see Fig. 1 – Part 2) from the fuses compartment
3. Rotate the switch in way to correctly read the “115V” or “230V” indication correspondent to the desired supply voltage
4. Restore the switch in the fuses compartment and close it

4.2 DESCRIPTION OF TEST LEADS

4.2.1 Front view



Fig. 2: HT2055M unit front view description

CAPTION:

1	ESC key to return at previous screen
2	MEM key for access to internal memory (see § 8)
3	◀, ▲, ▶, ▼ arrow keys and TEST key to activation measurements
4	Backlight key
5	LCD display
6	ON/OFF key to switch the instrument ON or OFF
7 - 8	◀ and ▶ keys for function selection and parameter settings

4.2.2 Top view

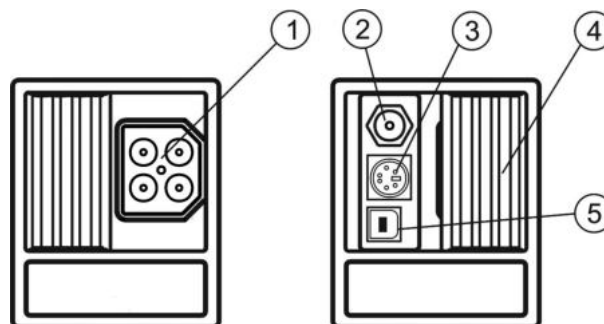

Fig. 3: HT2055M unit top view description

CAPTION:

1	Test connector. CAUTION: maximal allowed voltage between test terminals and ground is 50V. Maximal allowed voltage between test terminals is 100V
2	Power supply socket
3	PS/2 connector (for RS232 communication)
4	Protection cover
5	USB connection

4.2.3 Backside view

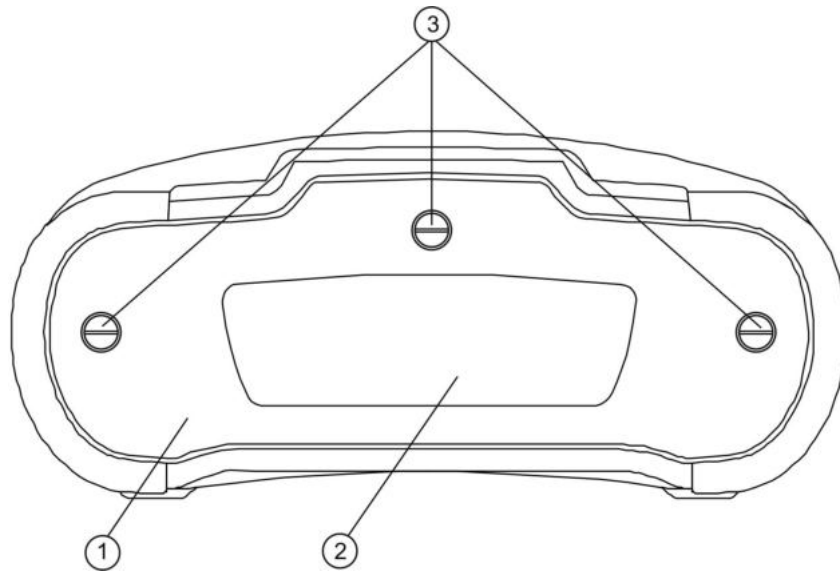

Fig. 4: HT2055M unit backside view description

CAPTION:

1	Battery compartment cover
2	Safety information label
3	Fixing screws for battery compartment cover

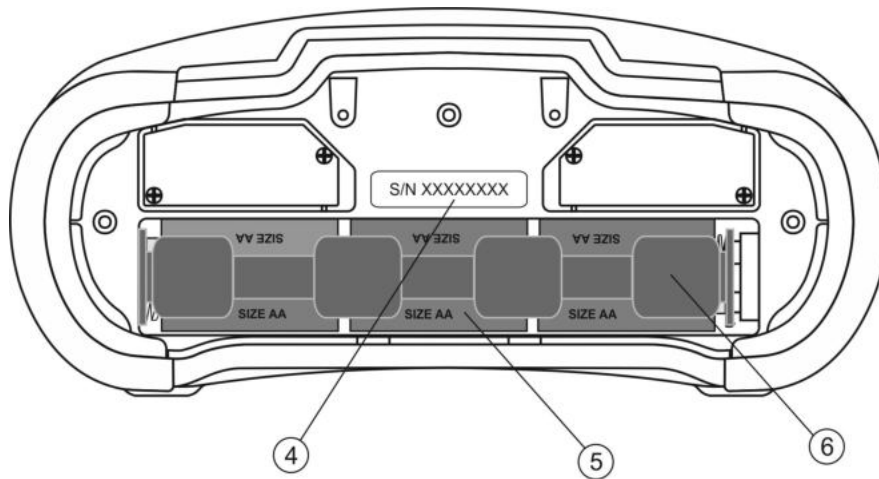

Fig. 5: HT2055M battery compartment description

CAPTION:

4	Serial number label
5	Battery cells (6x1.2V NiMH type AA)
6	Battery compartment

5 INITIAL OPERATIONS WITH HT2055M UNIT

Press the or function keys to display the below screens relative to the Step Voltage, Contact Voltage and Settings (see Fig. 6)

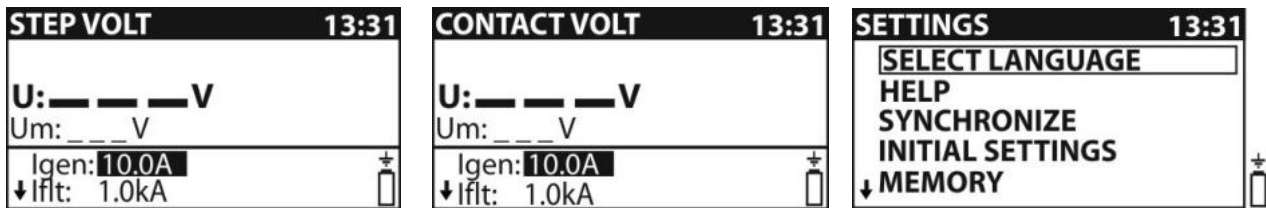

Fig. 6: Screens of general menu

5.1 SETTINGS

The below operations are possible within Settings menu:

- Language selection
- Help screens on connections
- Synchronizing with the station unit HT2055S
- Restore of default conditions
- Recall at display of saved results (see § 8.2) and clear memory (see § 8.3)
- Setting of system time/date

5.1.1 Language selection



Fig. 7: Screen of language selection

1. Press or keys to enter Settings menu
2. Select the item "Select Language" with the or keys and press **TEST** key
3. Select the desired language with the or keys and confirm with **TEST** key
4. Press **ESC** key to exit and go back to the previous screen

5.1.2 Help screen



Fig. 8: Help screen

1. Press or keys to enter Settings menu
2. Select the item "Help" with the or keys and press **TEST** key
3. Select the desired help screen with the or keys
4. Press **ESC** key to exit and go back to the previous screen

5.1.3 Synchronization

Selecting this option will allow to upload different data from the station unit to the meter unit. The possible options are:

- Synchronization of the actual time/date and the generated current
- Uploading of test current results for Step / Contact voltage calculation
- Uploading of earth resistance and ground resistivity results



Fig. 9: Synchronization screen

1. Press or keys to enter Settings menu
2. Select the item "Synchronize" with the or keys and press **TEST** key
3. Connect both units by using the PS/2-RS-232 supplied cable
4. Select one of the below options with the or keys and confirm with **TEST** key

TIME, CURRENT	Station's time and date will be uploaded to the meter. Value of generator current will be uploaded to the meter
STEP/CONTACT VOLT	Values of logged generator currents I_{GEN} will be uploaded to the Meter for calculation of Step voltage or Contact voltage
EARTH RESULT	Stored earth resistance or ground resistivity results in the station will be uploaded to the meter

5. Press **ESC** key to exit and go back to the previous screen

CAUTION



- The main purpose of the Time/ Current synchronization is to enable a correction of the step and contact voltage results after the test. During the test the step and contact voltage results are calculated based on the I_{GEN} set on the meter. After the test the obtained results can be updated with the real generator currents I_{GEN} measured at the same time with the station. The stored U_{STEP} and $U_{CONTACT}$ values are then corrected according to the following formula:

$$U_{STEP_{new}} = U_{STEP_{old}} \cdot \frac{I_{GEN(actually_generated)}}{I_{SET}}$$

$$U_{CONT_{new}} = U_{CONT_{old}} \cdot \frac{I_{GEN(actually_generated)}}{I_{SET}}$$

- The synchronization is active for 24 h
- If date / time are changed on the meter or station the synchronization of time and date will be lost. The current logger must be cleared before it can proceed with measurements. Before clearing it you can download its content to the meter

5.1.4 Default settings

This section permits to restore the default value (factory) of measurement parameters and limits set on the instrument



Fig. 10: Initial settings screen

1. Press or keys to enter Settings menu
2. Select the item "Initial Settings" with the or keys and press **TEST** key
3. Select the "NO" or "YES" options with the or keys and confirm with **TEST**
4. Press **ESC** key to exit and go back to the previous screen

The default values are the following:

Language	English
Contact and Step voltage	$I_{GEN} = 10A$ $I_{FLT} = 1kA$ $R_{INP} = 1M\Omega$ $U_{LIM} = 50V$

5.1.5 Time/Date settings



Fig. 11: Time/Date settings screen

1. Press or keys to enter Settings menu
2. Select the item "Set Date/Time" with the or keys and press **TEST** key
3. Use the , , and keys to set the date/time and confirm with **TEST**
4. Press **ESC** key to exit and go back to the previous screen

5.2 MESSAGES AT DISPLAY

The below messages (icons) can be displayed on the meter unit:

	The meter and the station are not synchronized
	Measurement is running
	Results can be stored
	Measurement result is within pre-set limits (PASSED)
	Measurement result is out of pre-set limits (FAILED)

6 INITIAL OPERATIONS WITH HT2055S UNIT

Press the or function keys to display the below screens relative to the earth/resistivity measurements and Settings (see Fig. 12)

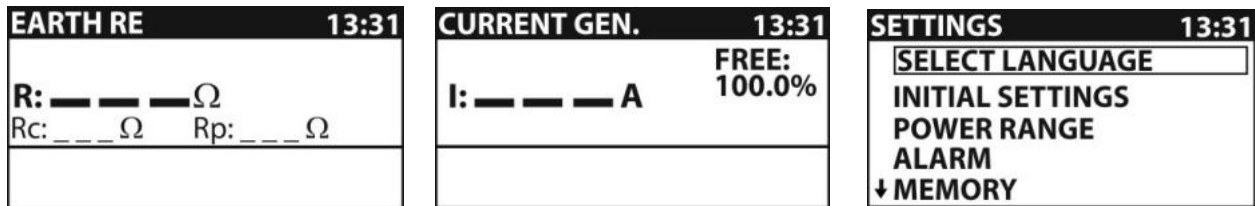

Fig. 12: Screens of general menu

6.1 SETTINGS

The below operations are possible within Settings menu:

- Language selection (see § 5.1.1)
- Restore of default conditions
- Setting power of current generator
- Setting of alarm conditions when switching off test current
- Recall at display of saved results (see § 8.2) and clear memory (see § 8.3)
- Time/date setting (see § 5.1.5)

6.1.1 Default settings

This section permits to restore the default value (factory) of measurement parameters and limits set on the instrument



Fig. 13: Initial settings screen

1. Press or keys to enter Settings menu
2. Select the item "Initial Settings" with the or keys and press **TEST** key
3. Select the "NO" or "YES" options with the or keys and confirm with **TEST**
4. Press **ESC** key to exit and go back to the previous screen

The default values are the following:

Contrast	50%
Language	English
Alarm	Disabled
Power of generator	100%
Distance "a"	2.0m

6.1.2 Setting output power

This section permits to set the output power of current generator by selecting the percentages: **10%**, **25%**, **50%**, **75%** and **100%**



Fig. 14: Output power generator setting screen

1. Press or keys to enter Settings menu
2. Select the item "Power Range" with the or keys and press **TEST** key
3. Select the desired percentage with the or keys and confirm with **TEST**
4. Press **ESC** key to exit and go back to the previous screen



CAUTION

When the current generator is started the output power is automatically set to the available maximum value. If the conditions change during the measurement the generator may switch off. Possible causes for switching off are:

- The output can become overloaded by high external earth currents. In this case it is recommended to decrease the output power down to 75% or 50% and restart the generator
- The current stopped flowing abruptly. If stop was caused by disconnection of the leads it is not necessary to lower down the power. The generator can be restarted.

6.1.3 Setting alarm condition

This section permits to set an acoustic alarm condition when stopping current generation due to noise effect or unexpected opening of circuit under test



Fig. 15: Alarm condition setting screen

1. Press or keys to enter Settings menu
2. Select the item "Alarm" with the or keys and press **TEST** key
3. Select the options "ENABLED" or "DISABLED" with the or keys and confirm with **TEST**
4. Press **ESC** key to exit and go back to the previous screen



CAUTION

An active alarm helps to avoid wrong interpretation of the Step and Contact voltage results. The readings will be close to 0 V if no test current is flowing

6.2 ADJUST CONTRAST OF DISPLAY

1. Press the key. The following screen is shown:



2. Use the ◀ or ▶ keys to reduce or increase the contrast percentage of display
3. Press the **TEST** key to confirm the operation or the **ESC** key to exit from this function

6.3 HELP SCREENS

1. Pressing screen to display the help screen correspondent to the selected function
2. Use the ◀ or ▶ keys to select the other help screens
3. Press **ESC** key to exit and go back to the previous screen

6.4 MESSAGES AT DISPLAY

The below messages/screens can be displayed by the station meter:

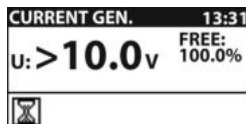

Voltage between test terminals C1/H and C2/E is higher than allowed (>10 V). Disconnect the test leads and check why an external voltage was detected

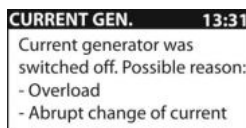

During current generation output was overloaded or test current abruptly fell down. Overload can be caused by high spurious earth current. In this case it is recommended to decrease the output power (see § 6.1.2)

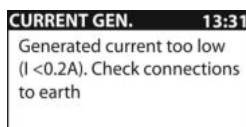

Output current is too low (< 0.2A). A too low current can be caused because of bad connection or high probe resistance

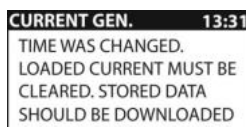

Date / time was changed in the station and consequently the synchronization between station and meter gets lost. The current logger must be cleared. Before clearing it its contents can be downloaded to the meter

	Output power is not set to maximum
	Measurement is running
	Results can be stored
	High electrical noise was detected during measurement. Results may be impaired
	High resistance of current (c) and/ or voltage (p) probes. Results may be impaired

7 HOW TO PERFORM THE MEASUREMENTS

7.1 THEORY OF STEP/CONTACT VOLTAGE MEASUREMENTS

An earth electrode / grid depleted into ground has a certain resistance, depending on its size, surface (oxides on the metal surface) and the soil resistivity around the electrode.

The earth resistance is not concentrated in one point but is distributed around the electrode. Correct connection of exposed conductive parts assures that the voltage on them stays below dangerous level in case of a fault.

If a fault happens a fault current will flow through the earth electrode. A typical voltage distribution occurs around the electrode (the “voltage funnel”). The largest part of the voltage drop is concentrated around the earth electrode. The Fig. 16 shows how fault, step and contact voltages occur as a result of fault currents flowing through the earth electrode / grid in the ground.

Fault currents close to power distribution objects (substations, distribution towers, plants) can be very high, up to 200 kA. This can result in dangerous step and contact voltages. If there are underground metal connections (intended or unknown) the voltage funnel can get atypical forms and high voltages can occur far from the point of failure. Therefore the voltage distribution in case of a fault around these objects must be carefully analyzed.

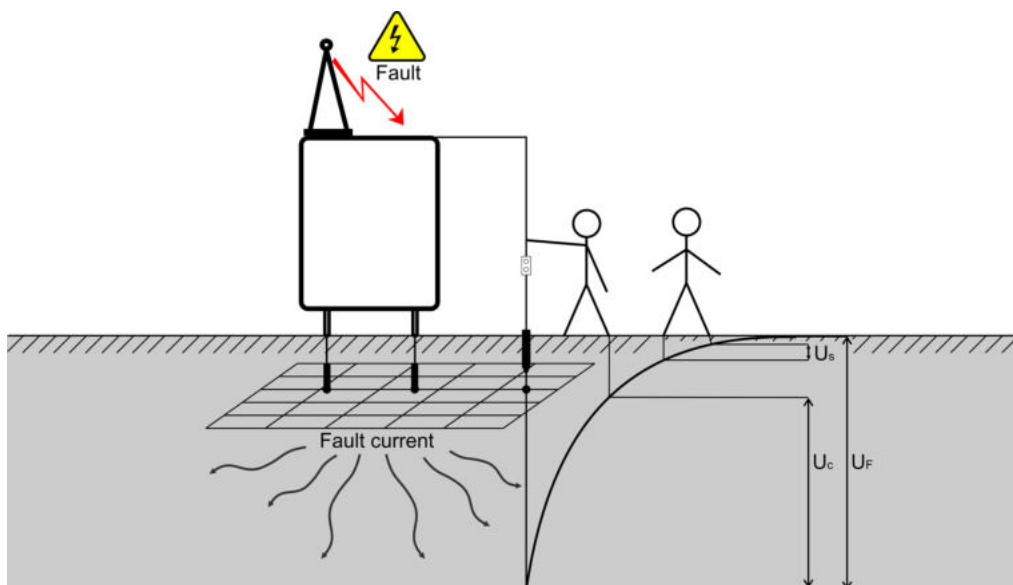

Fig. 16: Dangerous voltages on a faulty earth system

The guidelines define limit values of step/contact voltages depending on the time of fault elimination by the protection devices (typically declared by the Mains Energy provider). If the value of fault voltage is over this limit it is necessary to verify that the values of step/contact voltages in some potentially dangerous points of the plants (e.g: access areas, close to metal structures normally de-energized, gates, safety nets, etc) fall within standard values.

7.2 STEP/CONTACT VOLTAGE MEASUREMENT

The measurements of step/contact voltage are performed by a voltmeter with an internal resistance of **1kΩ** simulating the body resistance and with two weight probes of 25 kg each simulating feet. **Alternatively it is possible to use two metal plates instead of weight probes on the ground where the operator stands.**

CAUTION



During the measurement a test current is injected into the earth through an auxiliary probe. The resistance of the auxiliary probe should be as low as possible in order to inject a high test current. The resistance can be decreased by using more probes in parallel or using an auxiliary earth system as auxiliary probe. A higher injected current improves the immunity against spurious earth currents.

As the test current is usually only a small fraction of the highest fault current the measured voltages must be up scaled according to the following equation:

$$U_{S,C} = U_{Measured} \frac{I_{Fault}}{I_{Gen}}$$

$U_{S,C}$calculated step or contact voltage in case of fault current

$U_{Measured}$ measured voltage during the test

I_{Fault}maximal earth current in case of a fault

I_{Gen}injected test current

Installation of station unit

- 1 Place the station unit close to the earth system under test (distance max. 10m). Connect the unit at the input terminal C1/H by using the supplied cable
- 2 Fit the auxiliary metal probe (1m length) on the ground at a distance of at least 5 times the maximum diagonal of the earth system under test (see Fig. 17). Connect the input terminal C2/E to the probe by using the 50m long cable (if enough) or use another customized cable for longer distances. The nature of the measurement method permits the use of different cables without any resistance compensation. Use also several probes connected in parallel among them if it is necessary to reduce the contact resistance on that point.

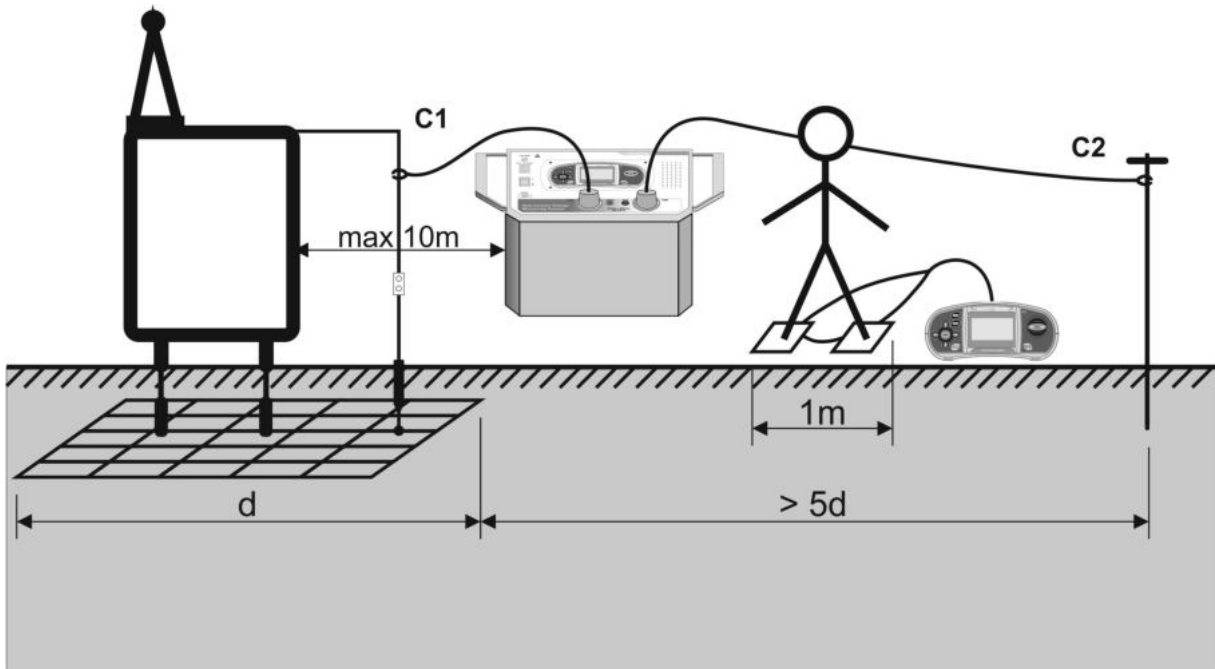

Fig. 17: Circuit scheme for step voltage measurement

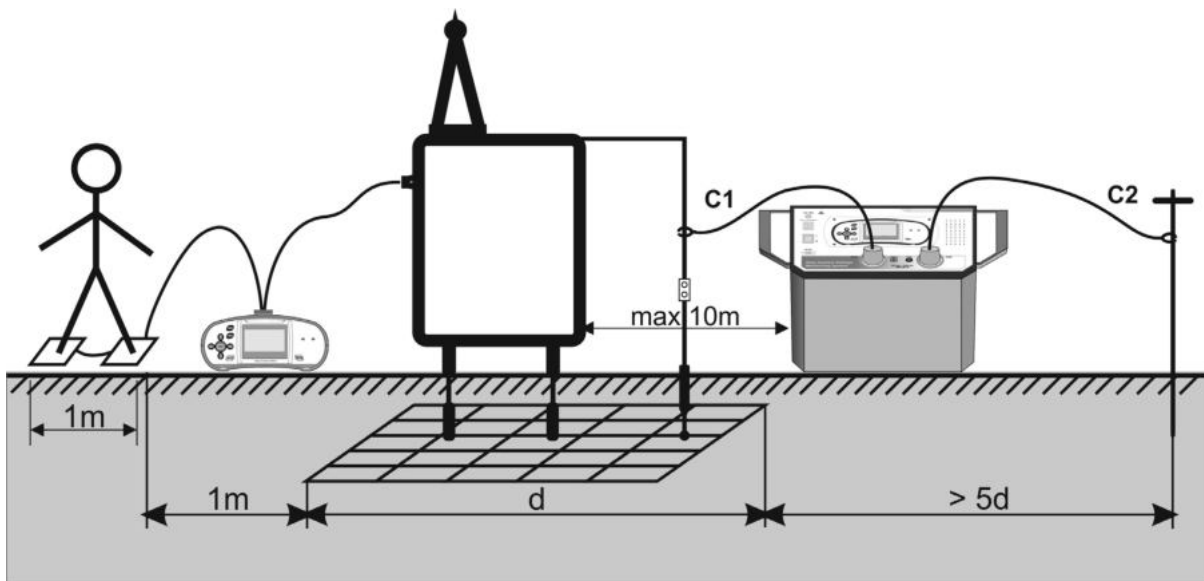

Fig. 18: Circuit scheme for contact voltage measurement

Generation of test current

- 3 Switch on the station unit HT2055S
- 4 Use or keys and select the "CURRENT GEN." screen (see Fig. 19)



Fig. 19: Test current generation screen

- 5 Press **TEST** key to activate the operation. The value of generated current is displayed. Check this value.



CAUTION

- The output power is set automatically to its available maximum value (see § 6.1.2)
- Completely unwind measuring cable to avoid affecting test current value (coil impedance)
- Usually the resistance of auxiliary probe can affect the generated test current. The injected current can be increased by placing more probes in parallel.

Synchronization between the units before the test (recommended)

Before starting with the step/contact voltage measurements it is recommended to synchronize the meter and the station units. The synchronization sets the same date and time in both units. Therefore the measured voltages can be correctly scaled after the measurements. If the current is generated during the synchronization its value is also sent to the meter unit (see § 5.1.3)

- 6 Connect both meter and station units through the PS/2-RS-232 cable supplied as accessory (see Fig. 20)

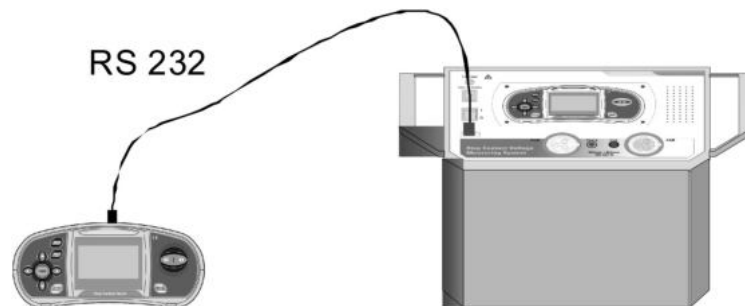

Fig. 20: RS-232 connection between units

- 7 Select the option “Synchronize → Time, Current” on the meter unit (see § 5.1.3) and confirm with **TEST** key. The messages “**Connecting...**” and “**Synchronizing...**” are displayed.



CAUTION

The measurements can be carried out without synchronization. In this case the measuring current must be set / changed manually. If the injected current is changing during the test the I_{GEN} parameter must be adjusted manually. The measurement results cannot be corrected after the measurement.

Perform step/contact voltage measurements

- 8 Use or keys and select the CONTACT VOLT or STEP VOLT measurements on the meter unit



Fig. 21: Screens for step/contact voltage measurements

- 9 Use , , and keys and perform the settings of the following test parameters:

Igen	Test current (manual setting considering the range 0.20A ÷ 50A) or automatically fitted by the station unit during the synchronization
Iflt	Maximum fault current of earth system (range 10A ÷ 200kA)
Rinp	Input resistance of the meter unit (1MΩ, 1kΩ)
Ulim	Limit value for step/contact voltage measurements (range 1V ÷ 10kV)

Iflt → Fault current value given by the Mains Energy provider

Rinp → Input resistance fixed to 1kΩ for step/contact voltage measurements

Ulim → Voltage limit given by Guidelines according to the time of fault elimination by the protection devices

- 10 Place and connect the test metal plates to each other where the operator stands, close to the points where step voltage measurement (see Fig. 17) or contact voltage (see Fig. 18) is required respecting the necessary distances
- 11 Connect the metal plates to the meter unit by using the cables supplied
- 12 Press **TEST** key on the meter unit and perform the step voltage of the contact voltage measurements. The following screens are displayed by the meter:



Fig. 22: Screens for results of step/contact voltage measurements

Where:

U → calculated step/contact voltage

Um → measured step/contact voltage

- 13 Press **MEM** key to save the result inside memory (see § 8.1)

Synchronization between the units after the test (recommended)

If the meter and station units were synchronized during the measurements they should be synchronized again after completing the tests. In this step the values of generated currents (measured with the station) are downloaded to the meter so automatically correcting the measured results previously stored and providing the correct value of step and contact voltages.

- 14 Connect both meter and station units through the PS/2-RS-232 cable supplied (see Fig. 20)
- 15 Select the option "Synchronize → Time, Current" on the meter unit (see § 5.1.3) and confirm with **TEST** key. The messages "**Connecting...**" and "**Synchronizing...**" are displayed.
- 16 The following screens can be displayed by the meter unit during the synchronization



Fig. 23: Example of screens on the synchronization operation

NOT SYNCHRONIZED → number of not synchronized results



CAUTION

Synchronization of step/contact voltage results can last up to several 10 seconds. A bargraph is showing the progress.

7.3 EARTH RESISTANCE MEASUREMENT

The earth resistance measurement is performed by the HT2055S station unit only by using the standard 3-wire method with two supplied auxiliary probes fitted at adequate distances from the earth system under test according to the Fig. 24

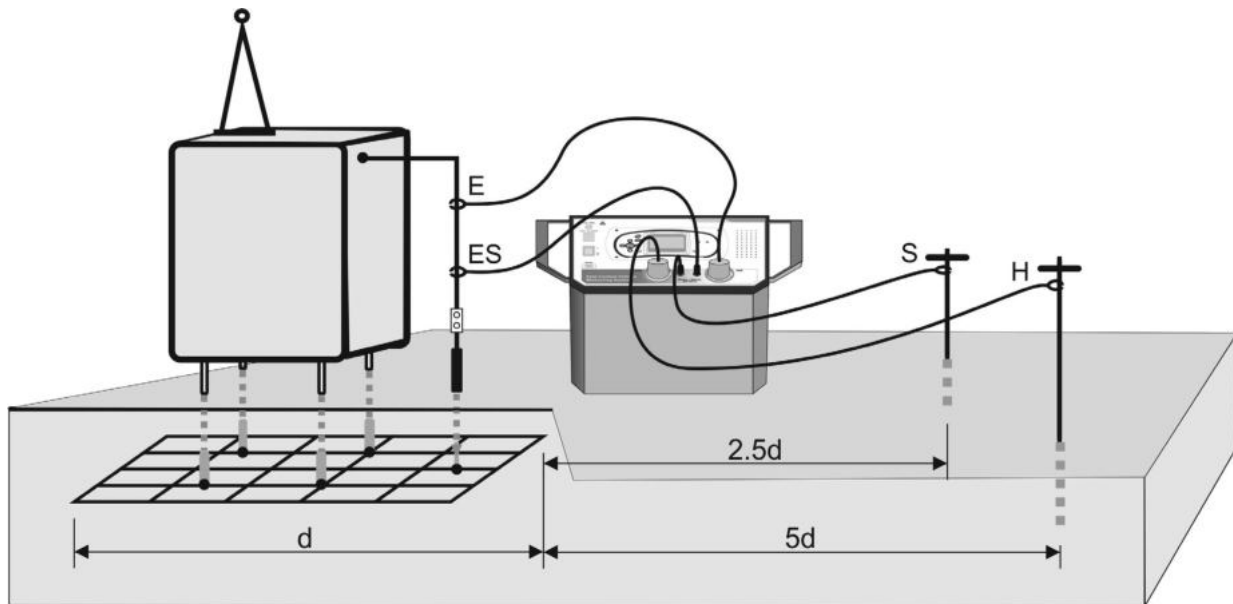

Fig. 24: Connection of instrument for earth resistance measurement

- 1 Place the station unit close to the earth system under test (distance max. 10m)
- 2 Connect the input terminals C2/E and ES to the earth system under test by using the cables supplied
- 3 Fit the auxiliary metal probe (1m length) on the ground at a distance of at least 5 times the maximum diagonal of the earth system under test (see Fig. 24). Connect the input terminal C1/H to the probe by using the 50m long cable supplied (if enough) or use another customized cable for longer distance. The nature of the measurement method permits the use of different cables without any resistance compensation. Use also more probes connected in parallel to each other if it's necessary to reduce the contact resistance on that point
- 4 Fit the auxiliary metal probe (60m length) on the ground at a distance of at least 2.5 times the maximum diagonal of the earth system under test (see Fig. 24). Connect the input terminal S to the probe by using the 50m long cable supplied (if enough) or use another customized cable for longer distance. The nature of the measurement method permits the use of different cables without any resistance compensation. Use also more probes connected in parallel to each other if it's necessary to reduce the contact resistance on that point

CAUTION



For large sized installations, place the ampere metric probe (H) at a distance equal to the diagonal of the earth installation and the volt metric probe (S) at a distance equal to about 0.5 times the diagonal of the earth installation. In the latter case several measurements shall be carried out moving the volt metric probe back and forth (along the measurement direction) with respect to the middle point and checking that the result is nearly constant

- 5 Use or keys and select the EARTH RE measurement on the station unit. The following screen is displayed:

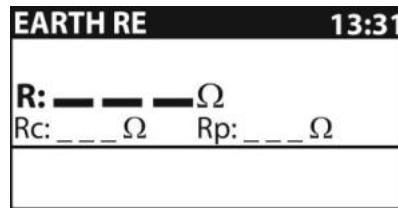

Fig. 25: Main screen of earth resistance measurement

- 6 Press **TEST** key to perform the measurement. The result is displayed



Fig. 26: Result screen of earth resistance measurement

Where:

- R → Measured value of earth resistance
 Rp → Voltage probe resistance (S)
 Rc → Current probe resistance (H)



CAUTION

- When starting test the unit performs a preliminary check of the resistance values for current probe (Rc) and voltage probe (Rp) stopping the test if these values are assumed to be too high and giving the following messages “Rc: >2.0kΩ” and “Rp: >2.0kΩ”. Decrease the value of these resistance wetting the ground close to the probes and/or connect more probes in parallel
- High noise currents and voltages on earth could affect the measurement results. In this case the tester displays the “NOISE” warning

- 7 Press **MEM** key to save the result inside memory (see § 8.1)



CAUTION

To view stored earth resistance results on PC they must be downloaded to the meter unit first. To download the results select earth results from Synchronize menu (see § 5.1.3). **After the results are downloaded the stored data in the station unit will be automatically deleted**

7.4 GROUND RESISTIVITY MEASUREMENT

For the ground resistivity measurement the test current is injected through two current probes (C1/H and C2/E). The voltage probes S and ES must be placed between the current probes (equidistance 'a' between probes must be considered). Using different distances between the test probes means that the material is measured at different depths. By increasing the distance 'a' a deeper layer of ground material is measured (see Fig. 27)

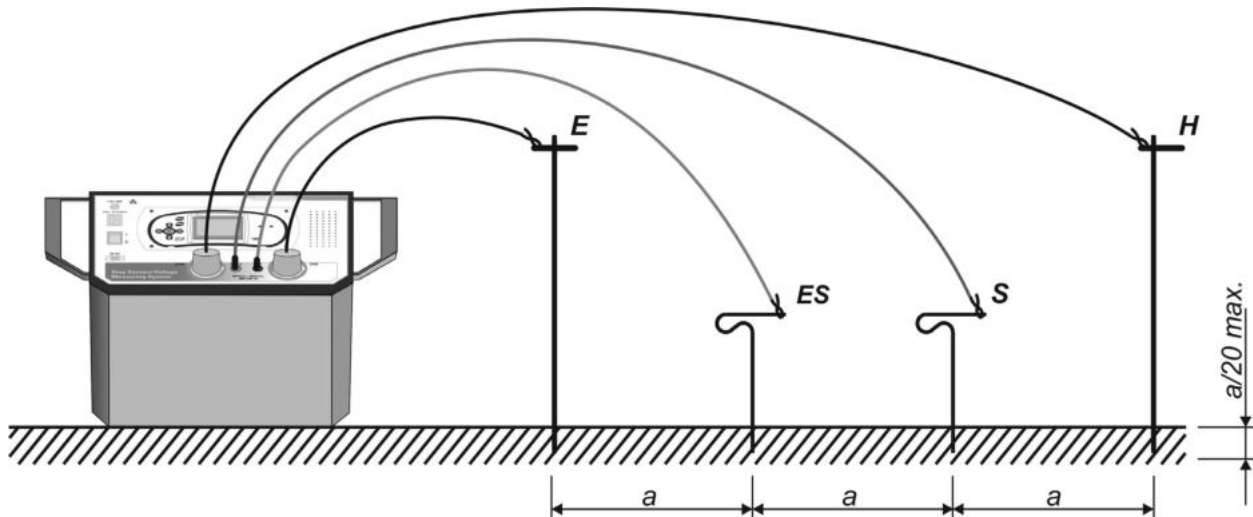

Fig. 27: Connection of the unit for ground resistance measurement

- 1 Use or keys and select the EARTH RE measurement on the station unit
- 2 Use the or keys to select the "EARTH ρ " measurement. The below screen is displayed:

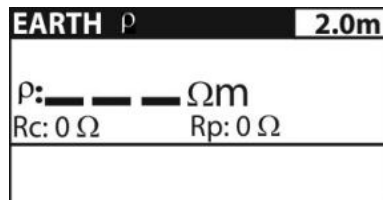

Fig. 28: Main screen of ground resistance measurement

- 3 Use the or keys to select the "a" parameter. Use the or keys to set the value expressed in meters into the range $0.1 \div 30.0$ by steps of 0.1m
- 4 Fit the auxiliary test probes at the same distance "a" set on the station unit and connect the input terminals C1/H, C2/E (current probes), ES and S (voltage probes) to the earth system under test by using the cables supplied as accessories (see Fig. 27)
- 5 Press **TEST** key to perform the measurement. The result is displayed



Fig. 29: Result screen of ground resistance measurement

Where:

ρ → Measured value of ground resistivity

Rp → Voltage probe resistance (sum of S+ES)

Rc → Current probe resistance (sum of C1/H +C2/E)

CAUTION



- When starting test the unit performs a preliminary check of the resistance values of current probe (Rc) and voltage probe (Rp) stopping the test if these values are assumed to be too high and giving the messages "**Rc: >2.0kΩ**" and "**Rp: >2.0kΩ**". Decrease the resistance value wetting the ground close to the probes and/or connect more probes in parallel
- High noise currents and voltages in earth could affect the measurement results. In this case the tester displays the "NOISE" warning

6 Press **MEM** key to save the result inside memory (see § 8.1)

CAUTION



To view stored ground resistivity results on PC they must be downloaded to the meter unit first. To download the results select earth results in Synchronize menu (see § 5.1.3). **After the results are downloaded the stored data in the station unit will be automatically deleted**

8 OPERATION WITH MEMORY

The measurement results, including associated parameters, can be saved inside the internal memories of station unit and meter unit. In particular:

- The step/contact voltage measurements can be saved in the meter unit
- The earth resistance/ground resistivity measurements can be saved in the station unit and then transferred to the meter unit
- The values of generated currents are automatically saved in the station unit

The internal memory of both units is divided into 3 levels with max 199 locations each. The number of measurements which can be saved in a location is only limited by the available memory

The internal memory (see Fig. 30) includes two types of structures:

- The data structure → defines the order of the saved results with the division into “OBJECTS” and “LOCATIONS”
- The structure of measurements → defines the information on the type and the number of measurements associated to the selected data structure (Object and Location)

RECALL RESULTS OBJECT 001 LOC1 001 > LOC2 001 <hr/> No.: 1	RECALL RESULTS > OBJECT 001 ----- ----- <hr/> No.: 7 [13]	RECALL RESULTS > OBJECT 001 ----- ----- <hr/> > No.: 7/7 STEP VOLT
---	--	--

Fig. 30: Structure of internal memory of the meters

This kind of structure permits an easy manipulation of saved data as:

- The results are organized and structured into groups
- The surfing among the saved results is simplified
- The printed report can be created with or without minor modifications after the downloading to PC

Data structure

RECALL RESULTS	Type of operation inside the memory
OBJECT 001 LOC1 001 LOC2 001	Data structure (OBJECT, LOCATIONS)
OBJECT 001	1st level → OBJECT: defines the default name of the object which is an associated reference number
LOC1 001	2nd level → LOC1: defines the first measurement point which is associated reference number relative to the saved data
LOC2 001	3rd level → LOC2: defines the second measurement point which is associated reference number relative to the saved data

Measurement structure

No.: 1	Number of measurements associated to the selected location
No.: 1 [13]	Number of measurements in the selected location [Number of measures in the selected location and sub-locations]
> No.: 7/7	Number of selected test / Number of all results saved in the selected location
STEP VOLT	Type of measurement saved in the selected location

8.1 SAVING RESULTS

At the end of a measurement test the result and the parameters can be saved into memory (the icon is shown in the bottom part of display). For saving result follow the following steps:

- 1 Press **MEM** key on the meter. The herewith screen is displayed:

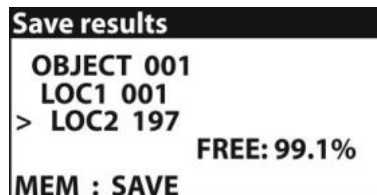

Fig. 31: Saving results inside memory

- 2 The "FREE" message means the percentage value of memory still available for saving operation
- 3 Use the **▼** or **▲** keys to select the type of location (Object / Loc1 / Loc2) and the **◀** or **▶** to decrease or increase the numerical marker associated to the location (range 1 ÷ 199)
- 4 Press again **MEM** key to complete the saving of data or the **ESC** key to exit without saving

8.2 RECALL RESULT AT DISPLAY

The recall of result at display can be performed in the following equivalent ways:

- By pressing **MEM** key in any measurement screen of the meter
- Selecting the item "MEMORY → RECALL RESULTS" in settings menu (see § 5.1)



Fig. 32: Recall results at display

- 1 Use the **▼** or **▲** keys to select the type of location (Object / Loc1 / Loc2) and the **◀** or **▶** to decrease or increase the numerical marker associated to the location (range 1 ÷ 199)
- 2 Press **TEST** key to select the number of the desired measurement
- 3 Press again **TEST** key for recall at display the result of desired measurement

8.3 DELETE SAVED RESULTS

The following operations are available:

- Deletion of all memory
- Deletion of data in single selected locations
- Deletion of generated currents (only for station unit)

Deletion of internal memory

- 1 Selected the item “MEMORY → CLEAR ALL MEMORY” inside settings menu (see § 5.1). The following screen is displayed



Fig. 33: Deletion of internal memory

- 2 Press **TEST** key to confirm the operation. The message “CLEARING MEMORY” is displayed
- 3 Press **ESC** key to exit without performing any operation

Deletion of single measurement

- 1 Select the item “MEMORY → DELETE RESULTS” inside settings menu (see § 5.1). The following screen is displayed

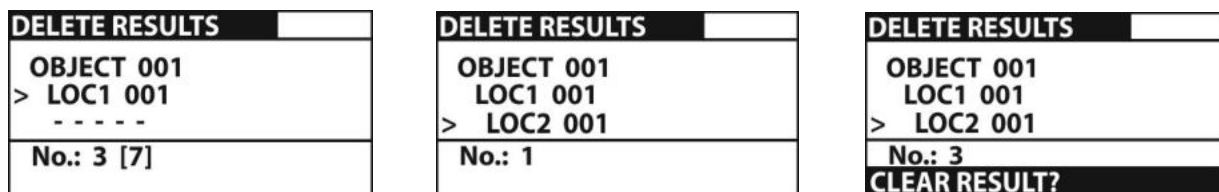

Fig. 34: Deletion of single measurement

- 2 Use the ▼ or ▲ keys to select the type of location (Object / Loc1 / Loc2) and the ◀ or ▶ to decrease or increase the numerical marker associated to the location (range 1 ÷ 199)
- 3 Press **MEM** key. The message “CLEAR RESULTS?” is displayed
- 4 Press **TEST** key to confirm the operation or **ESC** to exit the function

Deletion of generated currents

If the meter and station units are synchronized (see § 5.1.3 and § 7.2) the values of generated currents are stored (together with time and date) in a separated part of the station’s memory. For delete this currents on the station unit follow the herewith steps:

- 1 Select the item “MEMORY → CLEAR CURRENT LOG” inside settings menu. The following screen is displayed



Fig. 35: Delete generated currents

2. Press **TEST** key to confirm the operation. The message “CLEARING MEMORY” is displayed or press **ESC** to exit the function

9 CONNECTION OF THE INSTRUMENT TO PC

The saved data can be transferred to PC by using the **TeraView** software provided with instrument.

TeraView software permits the following operations:

- Download data from meter
- Define customized settings on the final report
- Analyse the results of measurements in numerical and graphical screens
- Print the final report
- Export the data to text (TXT) format file

MINIMUM SYSTEM REQUIREMENTS

Pentium III – 500MHz

512 MB RAM

100 MB free space on HD

CD-ROM reader

USB/serial port

Video resolution 800x600

Windows systems: Win2k/XP/Vista/Win7 32 bit and 64 bit platforms

9.1 INSTALLATION OF SOFTWARE AND INITIAL CONFIGURATIONS (WIN XP)

1. Close all open applications on the PC
2. Insert the supplied CD-ROM in the PC reader
3. Launch the “TeraView.exe” file included on CD-ROM and follow the steps to correctly install the TeraView software
4. Switch on the instrument and connect it to the PC by using the supplied USB cable or the PS/2 – RS-232 serial cable connected to a COM port. The USB port have always priority
5. Read the “Instal_USB_neutral.pdf” file inside the “Handbook” folder for the installation of USB driver on the PC
6. Launch the TeraView software
7. Select the command “**Config → Password...**”, type the serial number of meter and the password (which is indicated on the CD-ROM label) and confirm with “Add” (see Fig. 36)

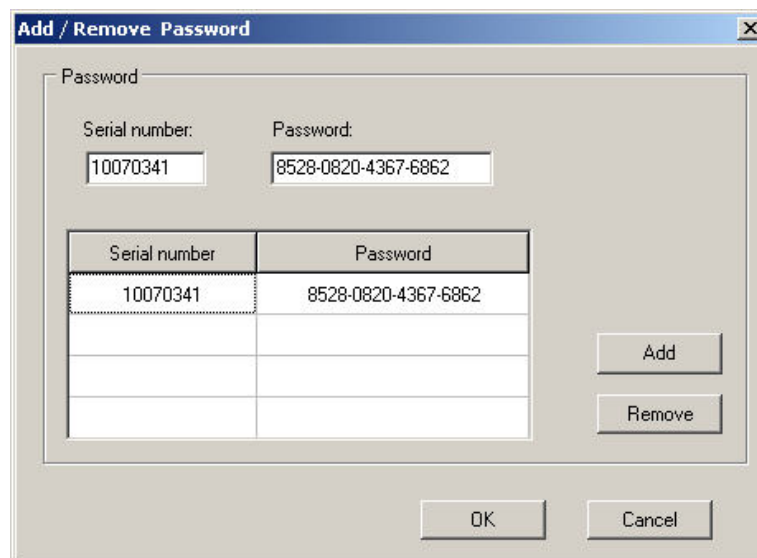

Fig. 36: Insertion of initial password

8. Select the “**Config → COM Port...**” command and click on the “AutoFind” button to start the automatic detection of the instrument (see Fig. 37)

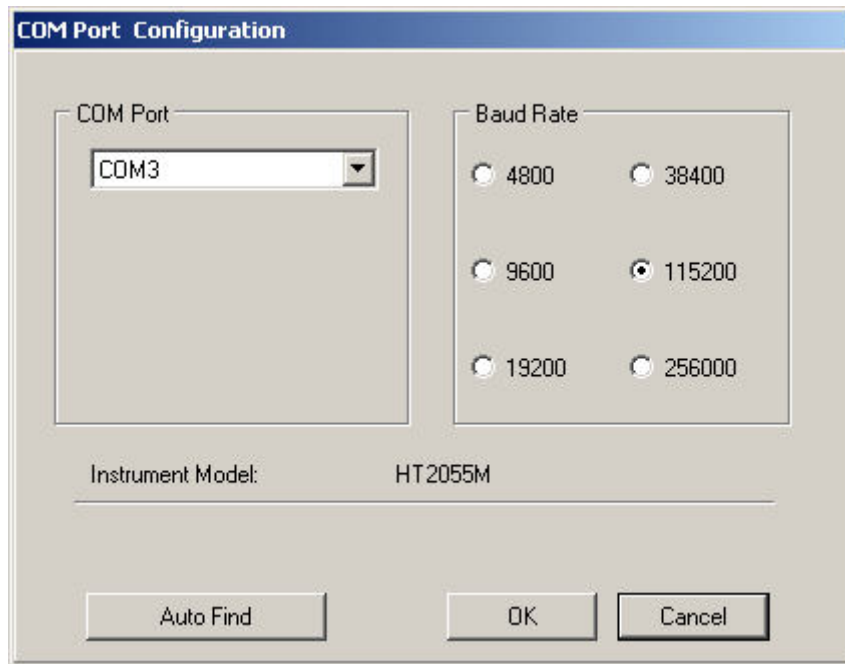

Fig. 37: Connection of the instrument to PC

9. The herewith message means a correct detection of meter by the PC

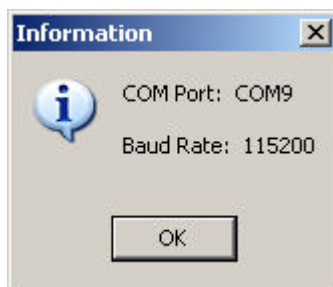

Fig. 38: Correct detection of instrument

10. In case of meter detection failure by the PC it should be necessary to re-configure the “virtual” COM serial port associated with the USB driver previously installed. The TeraView program can detect automatically serial ports from **COM1** to **COM22**. Follow the following steps to modify the COM associated to USB driver:
- Right click of mouse on the “**My computer**” icon on the PC desktop and selection of “Properties” item
 - “Hardware” folder → “Device Manager” → “Ports (COM & LPT)
 - Move on the “USB CDC Serial Port Emulation (COMxx)” item → right click → “Properties”
 - Select “Port Settings” → “Advanced...”
 - In the COM Port Number list select a “COMxx” among COM1 and COM22
 - Confirm all operations, come back to software TeraView and repeat the AutoFind

For any information about the use of TeraView software refer to the help on line of the program

10 MAINTENANCE

CAUTION



- During use and storage, carefully observe the recommendations listed in this manual in order to prevent possible damage or dangers during use
- Do not use the instrument in environments with high humidity levels or at high temperatures. Do not directly expose to sunlight. Always turn off the instrument after use. Never remove the front panel of the instrument. The instrument don't need any particular maintenance

10.1 REPLACEMENT AND CHARGING BATTERIES

The instrument is power-supplied through internal rechargeable batteries 6x1.2V NiMH type AA LR03 which are recharged from the mains by means of a supplied battery charger. The Fig. 39 – left part - shows the low battery level and the need of a recharging operation. The symbol of recharging battery is shown in Fig. 39 – right



Fig. 39: Condition of low battery level and recharging

In case of batteries replacement follow the following steps:

CAUTION



Turn the power off and disconnect any measurement accessories or mains supply cable connected to the instrument before opening the battery cover to avoid electric shock

1. Remove the three screws (see Fig. 4 – Part 3) and open the battery cover
2. Replace all the batteries with others of the same type respecting the indicated polarity
3. Restore the battery cover
4. Use the appropriate battery disposal methods for your area

10.2 REPLACEMENT FUSES OF HT2055S UNIT

CAUTION



Switch off and disconnect any measurement accessories or mains supply cable before opening the fuses compartment to avoid electric shock

1. Open the fuses compartment (see Fig. 1 – Part 1) with a screwdriver
2. Extract the red switch (see Fig. 1 – Part 2) from the fuses compartment
3. Extract the damaged fuses in the lateral sides of switch and replace them with others of the same type (see § 11.1)
4. Restore the switch in the fuses compartment and close it

10.3 CLEANING THE INSTRUMENT

To clean the instrument, use a soft dry cloth. Never use humid cloths, solvents, water, etc.

10.4 END OF LIFE



Warning: the reported symbol indicates that the appliance, the batteries and its accessories must be disposed of separately and treated correctly.

11 TECHNICAL SPECIFICATIONS

Accuracy is calculated as $\pm[\%rdg + (\text{number of dgt} \times \text{resolution})]$ at reference condition indicated in § 11.2

Step/Contact voltage measurement (unit HT2055M)

Measured voltage range	Resolution	Accuracy
0.01 ÷ 19.99mV	0.01mV	$\pm(2.0\%rdg + 2dgt)$
20.0 ÷ 199.9mV	0.1mV	
200 ÷ 1999mV	1mV	
2.00 ÷ 19.99V	0.01V	
20.0 ÷ 59.9V	0.1V	

Calculated voltage range	Resolution	Accuracy
0.0 ÷ 99.9V	0.1V	calculated value (*)
100 ÷ 999V	1V	
1.00kV ÷ 9.99kV	10V	

(*) The calculated value of step/contact voltage is obtained by the relationship: $U_S = U_{mis} \cdot I_{ft} / I_{gen}$; $U_C = U_{mis} \cdot I_{ft} / I_{gen}$;

Fault current range (selectable):

1A ÷ 200kA

Input resistance (selectable):

1k Ω , 1M Ω

Noise reducing:

DSP 55Hz filtering, 64dB rejection of 50/60Hz noise

Earth resistance measurement (unit HT2055S)

Measurement range	Resolution	Accuracy
0.001 Ω ÷ 1.999 Ω	0.001 Ω	$\pm(2.0\%rdg + 5dgt)$
2.00 Ω ÷ 19.99 Ω	0.01 Ω	
20.0 Ω ÷ 99.9 Ω	0.1 Ω	$\pm(5.0\%rdg)$
100.0 Ω ÷ 199.9 Ω		

Open voltage:

< 50V AC

Test current:

< 7.5A

Frequency of test signal:

55Hz

Influence of probe resistance:

$\leq \pm(10\%rdg + 10dgt)$

(R_c, R_p)_{max}

(10 Ω + 100R) or 2k Ω considering lower value

Automatic test of probe resistance:

Yes

Automatic detection of voltage noise

Generated current range	Resolution	Accuracy
0.00 ÷ 9.99A	0.01A	$\pm(3.0\%rdg + 5dgt)$
10.0 ÷ 99.9A	0.1A	$\pm(3.0\%rdg + 3dgt)$

Generated current:

55A max

Test voltage:

<55V

Test frequency:

55Hz

Ground resistivity measurement (unit HT2055S)

Measurement range	Resolution	Accuracy
0.00 Ω m ÷ 9.99 Ω m	0.01 Ω m	Calculated value, considering accuracy of resistance to earth function
10.0 Ω m ÷ 99.9 Ω m	0.1 Ω m	
100 Ω m ÷ 999 Ω m	1 Ω m	
1.00k Ω m ÷ 9.99k Ω m	0.01k Ω m	
10.0k Ω m ÷ 99.9k Ω m	0.1k Ω m	

Measurement range	Resolution	Accuracy
0.00 Ω ft ÷ 9.99 Ω ft	0.01 Ω ft	Calculated value, considering accuracy of resistance to earth function
10.0 Ω ft ÷ 99.9 Ω ft	0.1 Ω ft	
100 Ω ft ÷ 999 Ω ft	1 Ω ft	
1.00k Ω ft ÷ 9.99k Ω ft	0.01k Ω ft	
10.0k Ω ft ÷ 299.9k Ω ft	0.1k Ω ft	

Principle of measure:

Wenner method $\rightarrow \rho = 2 \cdot \pi \cdot \text{distance} \cdot R$

11.1 GENERAL CHARACTERISTICS

Station unit HT2055S

Power supply:	115V/230VAC ($\pm 10\%$), 50/60Hz
Max. power consumption:	750VA
Protection on mains:	2x fuse T 6.3A / 500V (6mm x 30mm)
Safety of meter:	IEC/EN61010-1, IEC/EN61557-1
Safety of accessories:	IEC/EN61010-031
Installation over 1kVAC:	HD 637 S1
Step/contact measurement:	EN50522, IEC60936-1
Earth/resistivity measurement:	IEC/EN61557-5, IEC/EN60364
Spanish guideline:	RAT 2008
Insulation:	class I
Measurement category:	CAT II 300V, CAT IV 50V
Pollution degree:	3
Mechanical protection:	IP30
Display:	LCD dot matrix (128 x 64) with backlit
Internal memory:	1000 locations
Generated current:	saved for min 24h
Communication interface:	RS-232 (with meter unit HT2055M)
Dimensions (L x W x H):	563 x 257 x 275mm ; 22 x 10 x 11 in
Weight (without accessories):	29.5kg ; 60lv

Meter unit HT2055M

Internal power supply:	6x1.2V rechargeable batteries NiMH type AA LR03 6x1.5V alkaline batteries type AA LR03
Battery life (rechargeable):	12 hours (typical)
External power supply:	100-240V AC, 50-60Hz / 12V DC
Safety of meter:	IEC/EN61010-1
Safety of accessories:	IEC/EN61010-031
Insulation:	double insulation
Measurement category:	CAT IV 50V
Pollution degree:	2
Mechanical protection:	IP40
Display:	LCD dot matrix (128 x 64) with backlit
Auto Power OFF:	after 15 minutes of idleness (not disabled)
Internal memory:	1500 locations
Communication interface:	RS-232 and USB
Dimensions (LxWxH):	230 x 115 x 103mm ; 9 x 5 x 4 in
Weight (with batteries):	1.3kg ; 3lv

11.2 ENVIRONMENT

Reference temperature:	10°C ÷ 30°C ; (50°F ÷ 86°F)
Reference humidity:	35% ÷ 65%RH
Operating temperature:	0°C ÷ 40°C ; (32°F ÷ 104°F)
Operating humidity:	<85%RH
Storage temperature:	-10°C ÷ 60°C ; (14°F ÷ 140°F)
Storage humidity:	<80%RH

This instrument satisfies the requirements of Low Voltage Directive 2014/35/EU (LVD) and of EMC Directive 2014/30/EU
This instrument satisfies the requirements of 2011/65/EU (RoHS) directive and 2012/19/EU (WEEE) directive

11.3 STANDARD ACCESSORIES

- Station unit HT2055S
- Meter unit HT2055M
- Power cord for HT2055S unit
- Metal current probe, 1m length
- Metal voltage probe, 60cm length
- Metal plate (200x100mm), 2 pcs
- Test cable black, 50m, 10mm², with alligator clip, with industrial plug, on wheel
- Test cable black, 10m, 10mm², with alligator clip, with industrial plug
- Test cable red, 50m, on wheel
- Test cable green, 10m, with alligator clip, on wheel
- Test cable red, 1m, with alligator clip
- Test cable black, 1.5m
- Test cable black, with plug for HT2055M, 2x3m
- Alligator clip black, 4 pcs
- 6 x 1.2V rechargeable batteries NiMH type AA, LR03
- External adapter 100-240V AC / 12V DC
- USB cable
- RS-232 - PS/2 cable
- "TeraView" software on CD-ROM
- Soft carrying bag, 2 pcs
- Belt for use of HT2055M unit on neck
- User manual
- ISO9000 calibration certificates
- Wood carrying case

11.4 OPTIONAL ACCESSORIES

- Metal current probe, 1m length
- Metal voltage probe, 60cm length

12 SERVICE

12.1 WARRANTY CONDITIONS

This instrument is warranted against any material or manufacturing defect, in compliance with the general sales conditions. During the warranty period, defective parts may be replaced. However, the manufacturer reserves the right to repair or replace the product. Should the instrument be returned to the After-sales Service or to a Dealer, transport will be at the Customer's charge. However, shipment will be agreed in advance. A report will always be enclosed to a shipment, stating the reasons for the product's return. Only use original packaging for shipment; any damage due to the use of non-original packaging material will be charged to the Customer. The manufacturer declines any responsibility for injury to people or damage to property.

The warranty shall not apply in the following cases:

- Repair and/or replacement of accessories and battery (not covered by warranty).
- Repairs that may become necessary as a consequence of an incorrect use of the instrument or due to its use together with non-compatible appliances.
- Repairs that may become necessary as a consequence of improper packaging.
- Repairs which may become necessary as a consequence of interventions performed by unauthorized personnel.
- Modifications to the instrument performed without the manufacturer's explicit authorization.
- Use not provided for in the instrument's specifications or in the instruction manual.

The content of this manual cannot be reproduced in any form without the manufacturer's authorization.

Our products are patented and our trademarks are registered. The manufacturer reserves the right to make changes in the specifications and prices if this is due to improvements in technology.

12.2 SERVICE

If the instrument does not operate properly, before contacting the After-sales Service, please check the conditions of battery and cables and replace them, if necessary. Should the instrument still operate improperly, check that the product is operated according to the instructions given in this manual. Should the instrument be returned to the After-sales Service or to a Dealer, transport will be at the Customer's charge. However, shipment will be agreed in advance. A report will always be enclosed to a shipment, stating the reasons for the product's return. Only use original packaging for shipment; any damage due to the use of non-original packaging material will be charged to the Customer.