

ENGLISH

User manual



TABLE OF CONTENTS

| | | |
|--------|--|----|
| 1. | SAFETY PRECAUTIONS AND PROCEDURES | 2 |
| 1.1. | Preliminary | 2 |
| 1.2. | During use | 3 |
| 1.3. | After use | 3 |
| 1.4. | Measuring (overvoltage) categories definitions | 3 |
| 2. | GENERAL DESCRIPTION | 4 |
| 3. | PREPARATION FOR USE | 4 |
| 3.1. | Initial | 4 |
| 3.2. | Supply voltage | 4 |
| 3.3. | Storage | 4 |
| 4. | NOMENCLATURE | 5 |
| 4.1. | Instrument description | 5 |
| 4.2. | Description of function keys | 6 |
| 4.2.1. | HOLD/☼ key | 6 |
| 4.2.2. | RANGE key | 6 |
| 4.2.3. | MAX MIN key | 6 |
| 4.2.4. | MODE key | 6 |
| 4.2.5. | Auto Power OFF | 6 |
| 5. | OPERATING INSTRUCTIONS | 7 |
| 5.1. | DC Voltage measurement | 7 |
| 5.2. | AC Voltage measurement | 8 |
| 5.3. | Frequency and Duty Cycle measurements | 9 |
| 5.4. | Resistance measurements | 10 |
| 5.5. | Diode test and Continuity test | 11 |
| 5.6. | Capacitance measurement | 12 |
| 5.7. | Temperature measurement with type K probe | 13 |
| 5.8. | DC Current measurement | 14 |
| 5.9. | AC Current measurement | 15 |
| 6. | MAINTENANCE | 16 |
| 6.1. | General information | 16 |
| 6.2. | Batteries and fuses replacement | 16 |
| 6.3. | Cleaning | 16 |
| 6.4. | End of life | 16 |
| 7. | TECHNICAL SPECIFICATIONS | 17 |
| 7.1. | Technical features | 17 |
| 7.1.1. | Reference guidelines | 19 |
| 7.1.2. | General data | 19 |
| 7.2. | Environment | 19 |
| 7.2.1. | Environmental conditions | 19 |
| 7.3. | Accessories | 19 |
| 7.3.1. | Standard accessories | 19 |
| 7.3.2. | Optional accessories | 19 |
| 8. | SERVICE | 20 |
| 8.1. | Warranty conditions | 20 |
| 8.2. | After-sale service | 20 |

1. SAFETY PRECAUTIONS AND PROCEDURES

This meter is compliance with safety Standard IEC/EN61010-1 related to electronic measuring instruments. For your own safety and to avoid damaging the instrument follow the procedures described in this instruction manual and read carefully all notes preceded by this symbol .

When taking measurements:

- Avoid doing that in humid or wet places
- Avoid doing that in rooms where explosive gas, combustible gas, steam or excessive dust is present
- Keep you insulated from the object under test
- Do not touch exposed metal parts such as test lead ends, sockets, fixing objects, circuits etc.
- Avoid doing that if you notice anomalous conditions such as breakages, deformations, fractures, leakages of battery liquid, blind display etc
- Be particularly careful when measuring voltages exceeding 20V to avoid risks of electrical shocks

The following symbols are used:



CAUTION - refer to the instruction manual - an improper use may damage the instrument or its components



Double insulated meter



AC Voltage and Current



DC Voltage and Current



Ground reference

1.1. PRELIMINARY

- This instrument has been designed for use in environments of pollution degree 2
- It can be used for **VOLTAGE** and **CURRENT** measurements on installations of CAT III 600V
- You must comply with the usual safety regulations aimed at protecting you against the dangerous electric current and protecting the instrument against an incorrect operation
- Only the original test leads supplied along with the instrument guarantee compliance with the safety standards in force. They must be in a good conditions and, if necessary, replaced with identical ones
- Do not test nor connect to any circuit exceeding the specified overload protection
- Do not take measurements under environmental conditions exceeding the limits indicated in § 6.2.1
- Make sure that battery is correctly installed
- Before connecting the test probes to the installation make sure that the rotary selector is positioned on the right function
- Make sure that LCD and rotary selector indicate the same function

1.2. DURING USE

Read the recommendations which follow and the instructions in this manual:



CAUTION

An improper use may damage the instrument and/or its components or injure the operator.

- When changing the range, first disconnect the test leads from the circuit under test in order to avoid any accident
- When the instrument is connected to measuring circuits never touch any unused terminal
- When measuring resistors do not add any voltage. Although there is a protection circuit, excessive voltage could cause malfunctioning
- If during measurement the displayed values remain constant check whether the HOLD function is active

1.3. AFTER USE

- After using the instrument turn it off
- If you expect not to use the instrument for a long period remove the battery to avoid leakages of battery liquids which may damage its inner components

1.4. MEASURING (OVERVOLTAGE) CATEGORIES DEFINITIONS

The IEC/EN61010-1: Safety requirements for electrical equipment for measurement, control and laboratory use, Part 1: General requirements, gives a definition of measuring category, usually called overvoltage category. § 6.7.4: Measuring circuits:

Circuits are divided into the following measurement categories:

- **Measurement category IV** is for measurements performed at the source of the low-voltage installation
Examples are electricity meters and measurements on primary overcurrent protection devices and ripple control units
- **Measurement category III** is for measurements performed in the building installation.
Examples are measurements on distribution boards, circuit breakers, wiring, including cables, bus-bars, junction boxes, switches, socket-outlets in the fixed installation, and equipment for industrial use and some other equipment, for example, stationary motors with permanent connection to fixed installation
- **Measurement category II** is for measurements performed on circuits directly connected to the low voltage installation
Examples are measurements on household appliances, portable tools and similar equipment
- **Measurement category I** is for measurements performed on circuits not directly connected to MAINS
Examples are measurements on circuits not derived from MAINS, and specially protected (internal) MAINS-derived circuits. In the latter case, transient stresses are variable; for that reason, the norm requires that the transient withstand capability of the equipment is made known to the user

2. GENERAL DESCRIPTION

The instrument performs the herewith measurements:

- DC Voltage
- AC TRMS Voltage
- DC Current
- AC TRMS Current
- Resistance and Continuity test
- Capacitance
- Frequency
- Duty cycle
- Diode test
- Temperature with type K probe

All selectable by means of a rotary selector. Also are available the function keys (see § 4.2) and backlight feature.. The instrument disposes of an Auto Power OFF function consisting in an automatic switching off 15 minutes after last selector rotation.

3. PREPARATION FOR USE

3.1. INITIAL

This instrument was checked both mechanically and electrically prior to shipment. All possible cares and precautions were taken to let you receive the instrument in perfect conditions. Notwithstanding we suggest you to check it rapidly (eventual damages may have occurred during transport – if so please contact the local distributor from whom you bought the item). Make sure that all standard accessories mentioned in § 7.3.1 are included. Should you have to return back the instrument for any reason please follow the instructions mentioned in § 8.

3.2. SUPPLY VOLTAGE



The instrument is supplied by 2x1.5V battery type AAA IEC LR03. When battery is low, a “” low battery indication is displayed. To replace/insert battery please refer to § 6.2.

3.3. STORAGE



After a period of storage in extreme environmental conditions exceeding the limits mentioned in § 7.2.1 let the instrument resume normal measuring conditions before using it.

4.2. DESCRIPTION OF FUNCTION KEYS



4.2.1. HOLD/ key

By pressing **HOLD**  key the measured value is frozen on the display where the symbol **"HOLD"** appears. Pressing again **HOLD**  to disable this function and resume normal operation. By pressing the key at least 1s the enable/disable of backlight feature can be performed. This feature is active for any position of rotary selector and automatically disabled after approx. 30s.



4.2.2. RANGE key

By pressing **RANGE** key, the manual mode is activated and the "AUTO" symbol disappears from the display. Press **RANGE** cyclically to change the measuring range and fix the decimal point on the display. To restore the autorange keep **RANGE** key pressed for at least 1s or rotate the selector to another position. This feature is not active in **Hz%**, ,  and  positions.

4.2.3. MAX MIN key

Pressing the **MAX MIN** key once activates the detection of maximum and minimum values of the quantity being tested. Both values are constantly updated and are displayed cyclically every time the same key is pressed again. The display shows the symbol associated with the selected function: "MAX" for maximum value and "MIN" for minimum value. The flashing symbol "MAX MIN" shows the current value on the display. The **MAX MIN** key is not active when the HOLD function is activated. The function is not active for measurements **Hz%**,  and . Long pressing the **MAX MIN** key (or upon switching on the instrument again) allows quitting the function.

4.2.4. MODE key

By pressing **MODE** key the selection of a double measured functions which are present at display is performed. In particular this key is active in **Hz%**, ,  positions and to select between AC or DC voltage/current measurements.

4.2.5. Auto Power OFF

The instrument automatically turns off 15 minutes after last pressure of keys or last selector rotation. To resume operation turn the selector on **OFF** and turn on the instrument again.

5. OPERATING INSTRUCTIONS

5.1. DC VOLTAGE MEASUREMENT



CAUTION

The maximum input for DC voltage is 600V. Do not attempt to measure higher voltages to avoid electrical shocks or damages to the instrument.



Fig. 2: Using the meter for DC Voltage measurement

1. Switch on V_{DC} position. "DC" symbol is displayed
2. Insert the test leads into the jacks, the red plug into $mA\mu A V\Omega Hz\% \rightarrow \leftarrow \rightarrow \leftarrow \rightarrow$ jack and black plug into **COM** jack
3. Connect the red and black test leads to the positive and negative poles of the circuit under test respectively (see Fig. 2). The voltage value is displayed
4. If the message "O.L" is displayed the higher range is reached
5. The symbol "-" on the instrument display indicates that voltage has opposite direction with regard to the connection of Fig. 2
6. For use of HOLD, RANGE, MAX MIN functions please refer to § 4.2

5.2. AC VOLTAGE MEASUREMENT



CAUTION

The maximum input for AC voltage is 600V. Do not attempt to measure higher voltages to avoid electrical shocks or damages to the instrument.



Fig. 3: Using the instrument for AC Voltage measurement

1. Switch on **V~Hz%** position
2. Insert the test leads into the jacks, the red plug into **mAμAVΩHz%→←→** jack and black plug into **COM** jack
3. Connect the test leads to the circuit under test (see Fig. 3). The voltage value is displayed
4. If the message "**O.L**" is displayed the higher range is reached
5. For use of HOLD, RANGE, MAX MIN functions please refer to § 4.2

5.3. FREQUENCY AND DUTY CYCLE MEASUREMENTS



CAUTION

The maximum input for AC voltage is 600V. Do not attempt to measure higher voltages to avoid electrical shocks or damages to the instrument.

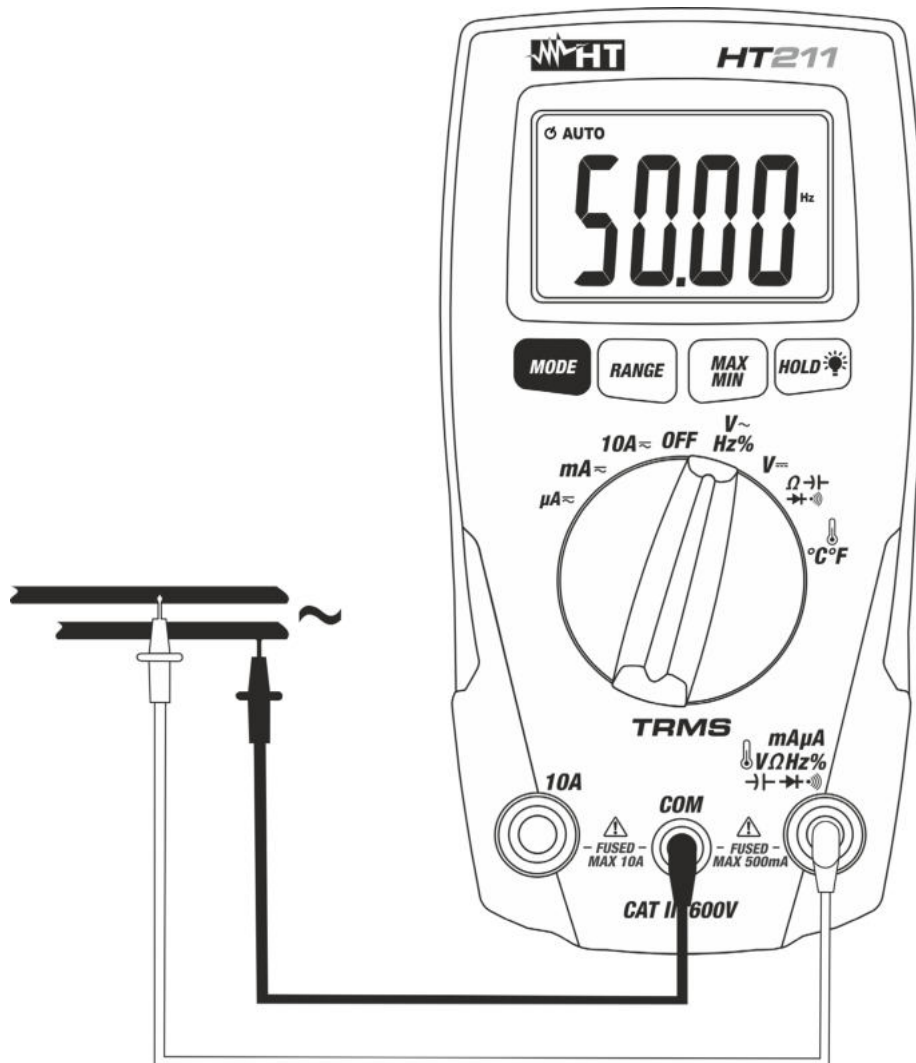

Fig. 4: Using the instrument for Frequency and Duty Cycle measurements

1. Switch on **V~Hz%** position
2. Press the **MODE** key until the symbol "Hz" is shown at display
3. Insert the test leads into the jacks, the red plug into **mA~AVΩHz%** jack and black plug into **COM** jack
4. Connect the test leads to the circuit under test (see Fig. 4). The frequency value is displayed
5. If the message "O.L" is displayed the higher range is reached
6. Press the **MODE** key until the symbol "%" is shown at display to meaning the Duty Cycle test and connect the meter as frequency measurement. The measured value is displayed
7. For HOLD function please refer to § 4.2

5.4. RESISTANCE MEASUREMENTS



CAUTION

Before taking resistance measurements in circuit remove power from the circuit being tested and discharge all capacitors.

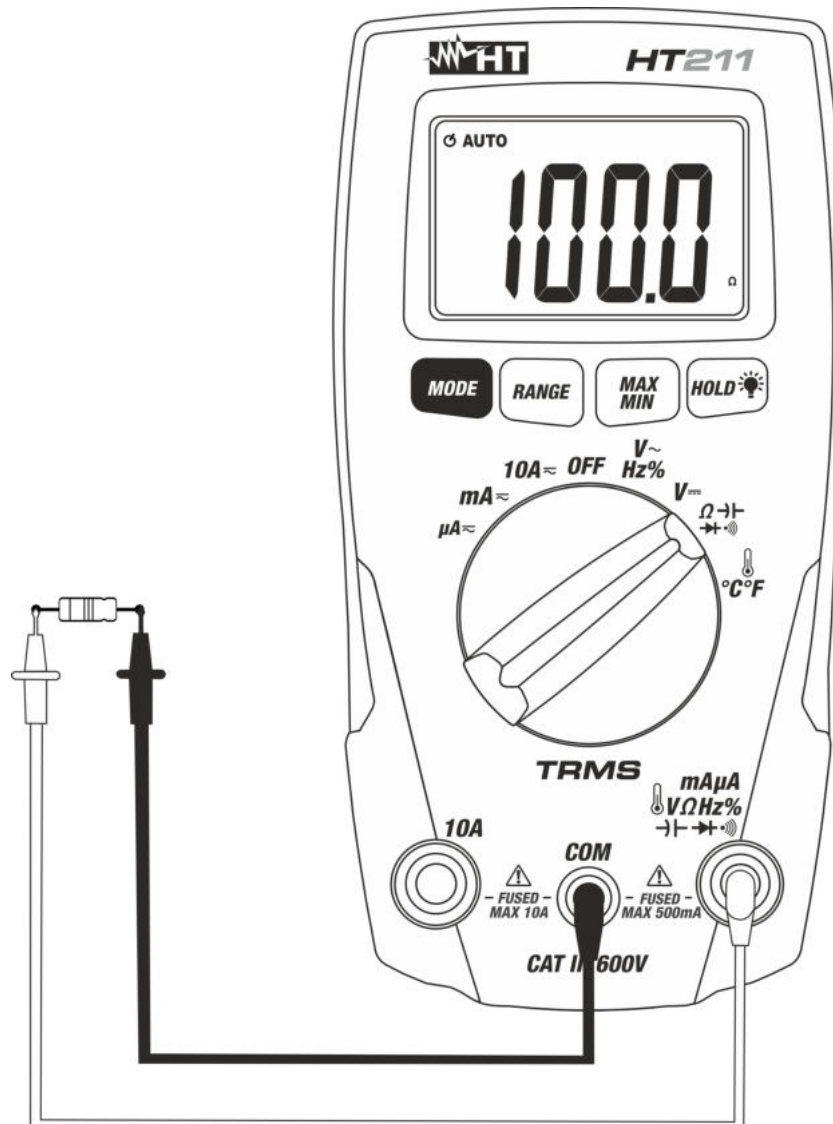

Fig. 5: Using the instrument for Resistance measurement

1. Switch on Ω position. "MΩ" symbol is displayed
2. Insert the test leads into the jacks, the red plug into Ω jack and black plug into **COM** jack
3. Connect the test leads to the circuit under test (see Fig. 5). The resistance value is displayed
4. If the message "**O.L**" is displayed the higher range is reached
5. For HOLD function refer to § 4.2

5.5. DIODE TEST AND CONTINUITY TEST



CAUTION

Before taking diode test measurements in circuit remove power from the circuit being tested and discharge all capacitors.

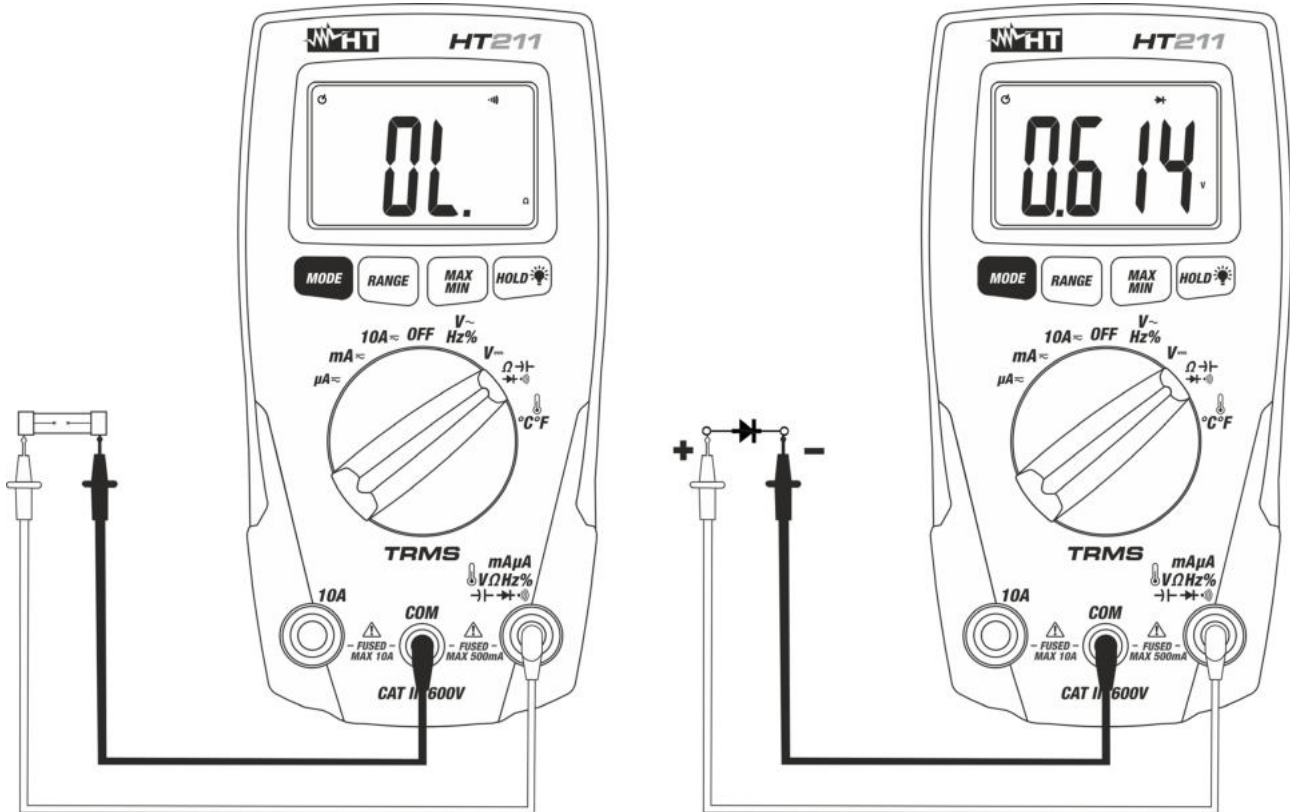

Fig. 6: Using the instrument for Diode test and Continuity test

1. Switch on $\Omega \rightarrow \text{diode symbol}$ position
2. Press the **MODE** key until the symbol “ \rightarrow ” is shown at display
3. Insert the test leads into the jacks, the red plug into $\text{mA} \mu\text{A} \text{V} \Omega \text{Hz} \% \rightarrow \text{diode symbol}$ jack and black plug into **COM** jack
4. Connect the test leads to the diode under test observing the proper polarities (see Fig. 6 – right part). The threshold voltage value under this situation is displayed
5. If the threshold voltage value is 0V the diode P-N junction is shorted circuit
6. If the message "O.L" is displayed the diode terminals are reversed, the diode P-N junction is damaged
7. Press the **MODE** key until the symbol “ \rightarrow ”) is shown at display to meaning the continuity test and connect the meter as resistance measurement (Fig. 6 – left part). Buzzer emits sound if the measured resistance value is $<50\Omega$
8. For HOLD function refer to § 4.2

5.6. CAPACITANCE MEASUREMENT



CAUTION

Before taking capacitance measurement in circuit remove power from the circuit being tested and discharge all capacitors. Connect the test capacitor to the inputs respecting the polarity connections when required.

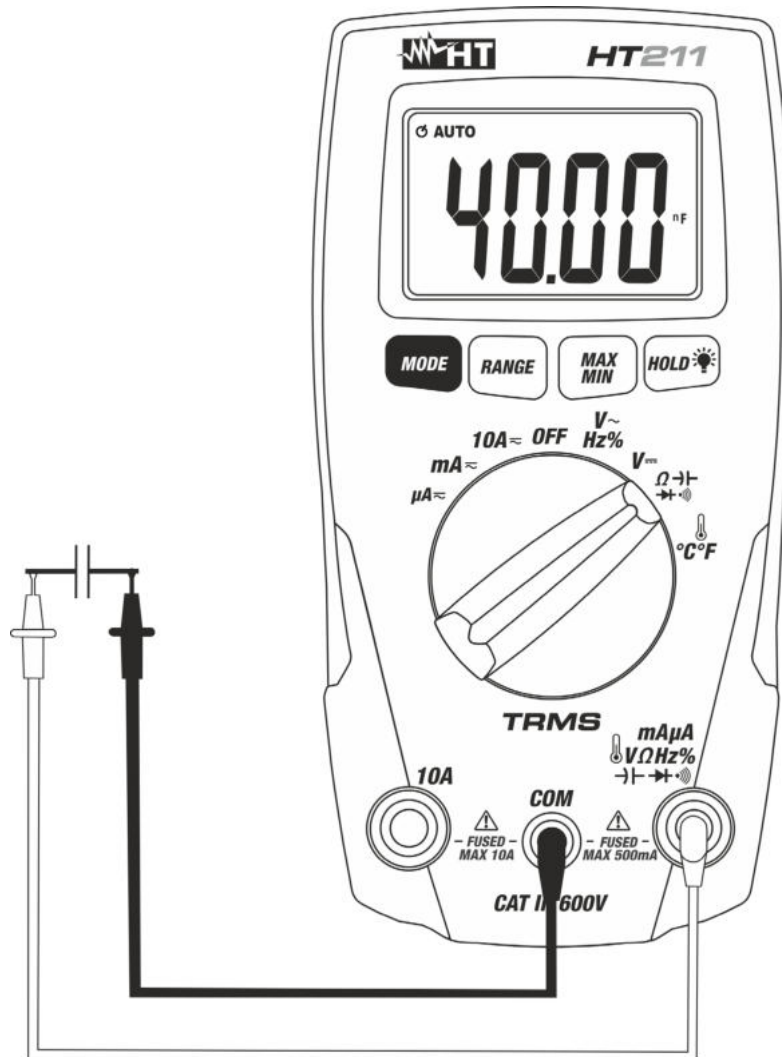

Fig. 7: Using the instrument for Capacitance measurement

1. Switch on $\Omega \rightarrow \rightarrow \rightarrow$)
2. Press the **MODE** key until the “nF” symbol is shown at display
3. Insert the test leads into the jacks, the red plug into $\text{mA} \mu\text{A} \text{V} \Omega \text{Hz} \% \rightarrow \rightarrow \rightarrow$) jack and black plug into **COM** jack
4. Connect the red and black test clamps to the capacitor terminals respecting if necessary the proper polarities (see Fig. 7). The capacitance value is shown on display
5. If the message "O.L" is displayed the higher range is reached
6. For HOLD function refer to § 4.2

5.7. TEMPERATURE MEASUREMENT WITH TYPE K PROBE



CAUTION

Before taking temperature measurements in circuit remove power from the circuit being tested and discharge all capacitors.

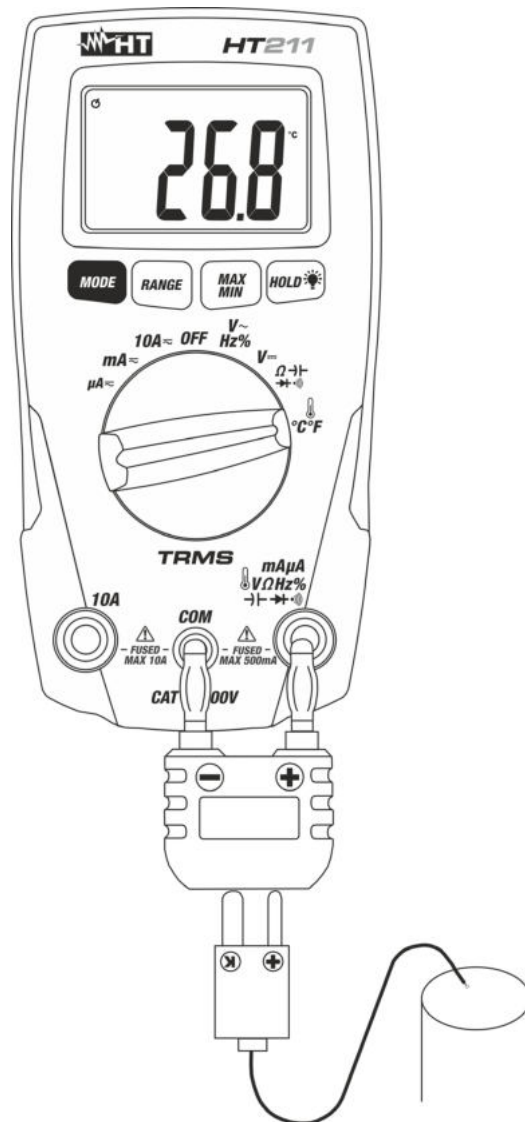

Fig. 8: Using the instrument for Temperature measurement

1. Switch on $^{\circ}\text{C}/^{\circ}\text{F}$ position.
2. Press the **MODE** key selecting the “°C” or “°F” unit
3. Insert the standard adapter accessory into $\text{mA}\mu\text{A}\text{V}\Omega\text{Hz}\% \rightarrow \text{---} \rightarrow \text{---} \rightarrow \text{---}$ jack (+ polarity), and **COM** jack (- polarity) (see Fig. 8)
4. Connect the standard bead type K probe or the optional type K probe (see § 7.3.2) into the adapter with respect the correct positive and negative polarity then temperature reading is displayed
5. If the message "O.L" is displayed the higher range is reached
6. For HOLD function measurement refer to § 4.2

5.8. DC CURRENT MEASUREMENT

CAUTION



The maximum input for DC current is 10A (10A input) or 400mA (mA input). Do not attempt to measure higher currents to avoid electrical shocks or damages to the instrument.

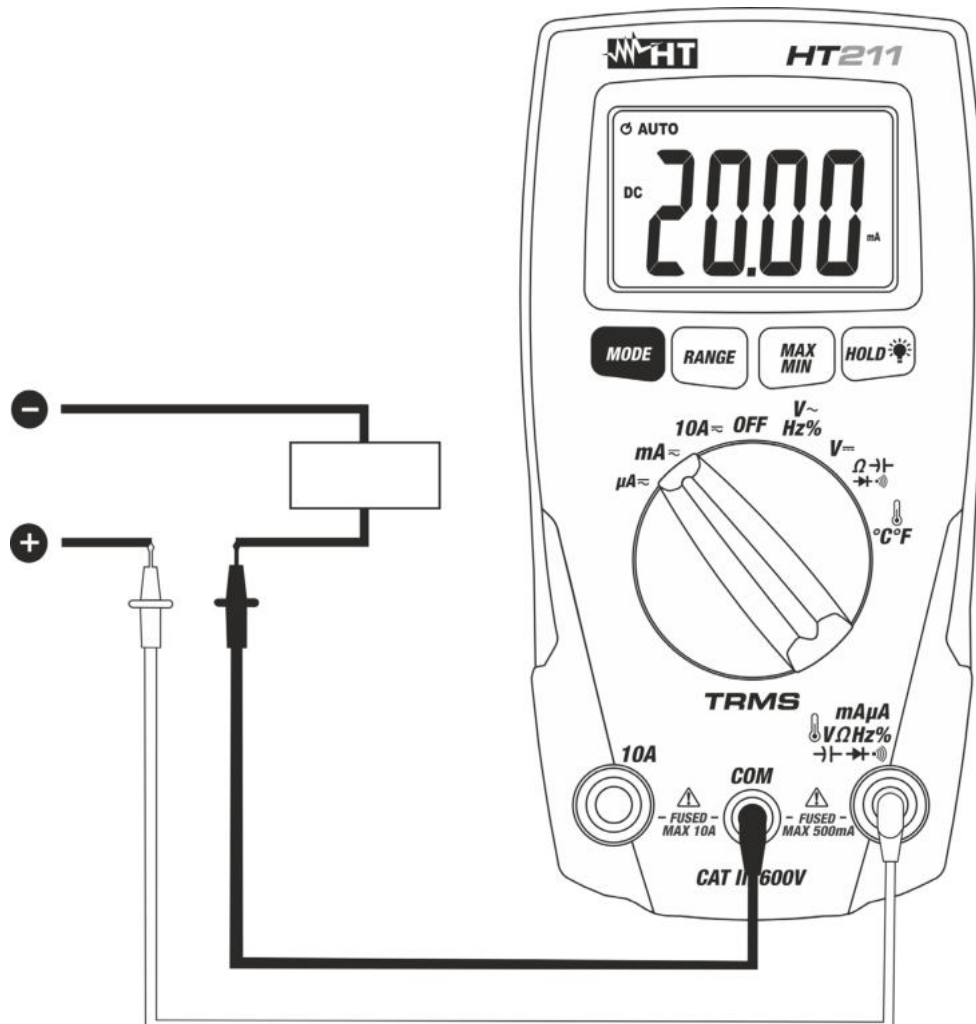

Fig. 9: Using the instrument for DC Current measurement

1. Power off the circuit under test
2. Switch on “ μA ”, “mA” or “10A”
3. Press the **MODE** key until the “DC” symbol is shown at display
4. Insert the test leads into the jacks, the red plug into 10A or mA input jack and black plug into COM jack
5. Connect the red and the black plugs in series with the circuit whose current is to be measured respecting the polarities (see Fig. 9)
6. Energize the circuit under test. The current value will be displayed.
7. The message "O.L" means that the detected current exceeds the limits.
8. The symbol "-" on the instrument display indicates that voltage has opposite direction with regard to the connection.
9. For use of HOLD, RANGE, MAX MIN functions please refer to § 4.2

6. MAINTENANCE

6.1. GENERAL INFORMATION

While using and storing the instrument, carefully observe the recommendations listed in this manual in order to prevent possible damage or danger during use. Do not use the instrument in environments with high humidity levels or high temperatures. Do not expose to direct sunlight. Always switch off the instrument after use. In case the instrument is not to be used for a long time, remove the battery to avoid liquid leaks that could damage the instruments internal circuits

6.2. BATTERIES AND FUSES REPLACEMENT

When the “” indication is displayed the batteries are to be replaced.



CAUTION

Only expert and trained technicians should perform maintenance operations. Before carrying out maintenance operations, disconnect all cables from the input terminals.

Batteries replacement

1. Turn **OFF** the instrument
2. Disconnect the test leads from the input terminals
3. Remove the two fixing screws and detach the battery cover
4. Replace the batteries with a new one of the same type (refer to § 7.1.2) observing the proper polarities
5. Replace the battery cover and screws
6. Use the appropriate battery disposal methods for your area

Fuses replacement

1. Turn **OFF** the meter and disconnect the test leads from the input terminals
2. Remove the two fixing screws and detach the battery cover
3. Remove the defective fuse and install a new fuse of the same size and rating (see § 7.1.2)
4. Restore the battery cover

6.3. CLEANING

Use a soft and dry cloth to clean the instrument. Never use wet cloths, solvents, water, etc.

6.4. END OF LIFE



CAUTION: this symbol indicates that equipment, the battery and its accessories shall be subject to a separate collection and correct disposal.

7. TECHNICAL SPECIFICATIONS

7.1. TECHNICAL FEATURES

Accuracy indicated as $\pm[\%rdg + (\text{num. dgt} * \text{resolution})]$ referred to $23^{\circ}\text{C} \pm 5^{\circ}\text{C}$, $<80\%RH$.

DC Voltage (Autorange)

| Range | Resolution | Accuracy | Input impedance | Overload protection |
|---------|------------|----------------------|-----------------|---------------------|
| 400.0mV | 0.1mV | $\pm(2.0\%rdg+8dgt)$ | 10M Ω | 600VDC/ACrms |
| 4.000V | 0.001V | $\pm(2.0\%rdg+3dgt)$ | | |
| 40.00V | 0.01V | | | |
| 400.0V | 0.1V | | | |
| 600V | 1V | $\pm(1.2\%rdg+3dgt)$ | | |

AC TRMS Voltage (Autorange)

| Range | Resolution | Accuracy (*) (50Hz ÷ 400Hz) | Input impedance | Overload protection |
|--------|------------|--------------------------------|-----------------|---------------------|
| 4.000V | 0.001V | $\pm(2.0\%rdg+5dgt)$ | 10M Ω | 600VDC/ACrms |
| 40.00V | 0.01V | $\pm(1.5\%rdg+3dgt)$ | | |
| 400.0V | 0.1V | | | |
| 600V | 1V | $\pm(2.0\%rdg+4dgt)$ | | |

(*) Accuracy referred to sinusoidal waveform. For not sinusoidal waveform the accuracy is $\pm(10.0\%rdg+5dgt)$

DC Current

| Range | Resolution | Accuracy | Overload protection |
|---------------|-------------|----------------------|------------------------|
| 400.0 μ A | 0.1 μ A | $\pm(1.5\%rdg+3dgt)$ | Fast fuse 500mA / 600V |
| 4000 μ A | 1 μ A | | |
| 40.00mA | 0.01mA | | |
| 400.0mA | 0.1mA | | |
| 4.000A | 0.001A | $\pm(2.5\%rdg+5dgt)$ | Fast fuse 10A / 600V |
| 10.00A | 0.01A | | |

AC TRMS Current

| Range | Resolution | Accuracy (*) (50Hz ÷ 400Hz) | Overload protection |
|---------------|-------------|--------------------------------|----------------------|
| 400.0 μ A | 0.1 μ A | $\pm(2.0\%rdg+5dgt)$ | Fast fuse 500mA/600V |
| 4000 μ A | 1 μ A | $\pm(2.5\%rdg+5dgt)$ | |
| 40.00mA | 0.01mA | | |
| 400.0mA | 0.1mA | | |
| 4.000A | 0.001A | $\pm(3.0\%rdg+7dgt)$ | Fast fuse 10A/600V |
| 10.00A | 0.01A | | |

(*) Accuracy referred to sinusoidal waveform. For not sinusoidal waveform the accuracy is $\pm(10.0\%rdg+5dgt)$

Resistance and Continuity test

| Range | Resolution | Accuracy | Buzzer | Overload protection |
|-----------------|-----------------|------------------------|--------------|---------------------|
| 400.0 Ω | 0.1 Ω | $\pm(1.0\%rdg + 4dgt)$ | <50 Ω | 250VDC/ACrms |
| 4.000k Ω | 0.001k Ω | $\pm(1.5\%rdg + 5dgt)$ | | |
| 40.00k Ω | 0.01k Ω | | | |
| 400.0k Ω | 0.1k Ω | | | |
| 4.000M Ω | 0.001M Ω | | | |
| 40.00M Ω | 0.01M Ω | | | |

Diode Test

| Feature | Max open voltage | Overload protection |
|---|------------------|---------------------|
|  | approx 1.5VDC | 250VDC/ACrms |

Frequency (Autorange)

| Range | Resolution | Accuracy | Sensitivity | Overload protection |
|----------|------------|------------------------|-------------|---------------------|
| 9.999Hz | 0.001Hz | $\pm(1.0\%rdg + 5dgt)$ | >5Vrms | 250VDC/ACrms |
| 99.99Hz | 0.01Hz | | | |
| 999.9Hz | 0.1Hz | | | |
| 9.999kHz | 0.001kHz | | | |

Duty cycle (Autorange)

| Range | Resolution | Accuracy | Sensitivity | Overload protection |
|------------|------------|------------------------|-------------|---------------------|
| 0.1%÷99.9% | 0.1% | $\pm(1.2\%rdg + 3dgt)$ | >1Vrms | 250VDC/ACrms |

0.01ms< pulse width <10ms; Frequency range: 10Hz ÷10kHz

Capacitance (Autorange)

| Range | Resolution | Accuracy | Overload protection |
|---------|------------|-------------------------|---------------------|
| 40.00nF | 0.01nF | $\pm(5.0\%rdg + 35dgt)$ | 250VDC/ACrms |
| 400.0nF | 0.1nF | $\pm(3.0\%rdg + 5dgt)$ | |
| 4.000μF | 0.001μF | | |
| 40.00μF | 0.01μF | $\pm(4.0\%rdg + 5dgt)$ | |
| 400.0μF | 0.1μF | | |
| 4000μF | 1μF | $\pm(5.0\%rdg + 5dgt)$ | |

Temperature with type K probe

| Range | Resolution | Accuracy (*) | Overload protection |
|-------------------|------------|------------------------------|---------------------|
| -20.0°C ÷ 760.0°C | 0.1°C | $\pm(3.0\%rdg + 5^{\circ}C)$ | 250VDC/ACrms |
| -4.0°F ÷ 1400.0°F | 0.1°F | $\pm(3.0\%rdg + 9^{\circ}F)$ | |

(*) Accuracy of only instrument without probe

7.1.1. Reference guidelines

| | |
|-----------------------|------------------------|
| Safety: | IEC/EN61010-1 |
| EMC: | IEC/EN61326-1 |
| Insulation: | double insulation |
| Pollution degree: | 2 |
| Measurement category: | CAT III 600V to ground |

7.1.2. General data

Mechanical characteristics

| | |
|-------------------------------|-------------------------------|
| Dimensions (L x W x H): | 145 x 70 x 60mm (6 x 3 x 2in) |
| Weight (including batteries): | 245g (9 ounces) |
| Mechanical protection: | IP40 |

Power supply

| | |
|-------------------------|--|
| Battery type: | 2x1.5V batteries AAA IEC LR03 |
| Low battery indication: | symbol "⊕-⊖" is displayed |
| Battery life: | ca 20h (backlight ON), ca 190h (backlight OFF) |
| Fuses: | F10A/600V, 5 x 20mm (10A input) F500mA/600V, 5 x 20mm (mAμA input) |
| Auto Power OFF: | after 15 minutes of idleness (not disabled) |

Display

| | |
|-----------------|--|
| Specifications: | 3 $\frac{3}{4}$ LCD, 4000 counts + sign, decimal point and backlight |
| Sampling rate: | 2 times/second |
| Conversion: | TRMS |

7.2. ENVIRONMENT

7.2.1. Environmental conditions

| | |
|------------------------|--------------------------------------|
| Reference temperature: | 23°C \pm 5°C (73°F \pm 41°F) |
| Working temperature: | 5°C \div 40°C (41°F \div 104°F) |
| Relative humidity: | <80%RH |
| Storage temperature: | -20°C \div 60°C(-4°F \div 140°F) |
| Storage humidity: | <80%RH |
| Max height of use: | 2000m (6562ft) |

This instrument satisfies the requirements of Low Voltage Directive 2014/35/EU (LVD) and of EMC Directive 2014/30/EU

This instrument satisfies the requirements of European Directive 2011/65/EU (RoHS) and 2012/19/EU (WEEE)

7.3. ACCESSORIES

7.3.1. Standard accessories

- Test leads
- Adapter + type K bead probe
- Battery
- Carrying case
- User manual

7.3.2. Optional accessories

- | | |
|---|------------|
| • Type K probe for air and gas | Cod. TK107 |
| • Type K probe for semi solid substances | Cod. TK108 |
| • Type K probe for liquid | Cod. TK109 |
| • Type K probe for surfaces | Cod. TK110 |
| • Type K probe for surfaces with a 90° lead | Cod. TK111 |

8. SERVICE

8.1. WARRANTY CONDITIONS

This instrument is guaranteed against material or production defects, in accordance with our general sales conditions. During the warranty period the manufacturer reserves the right to decide either to repair or replace the product. Should you need for any reason to return back the instrument for repair or replacement take prior agreements with the local distributor from whom you bought it. Do not forget to enclose a report describing the reasons for returning (detected fault). Use only original packaging. Any damage occurred in transit due to not original packaging will be charged anyhow to the customer. The manufacturer will not be responsible for any damage to persons or things.

The warranty doesn't apply to:

- Accessories and batteries (not covered by warranty)
- Repairs made necessary by improper use (including adaptation to particular applications not foreseen in the instructions manual) or improper combination with incompatible accessories or equipment
- Repairs made necessary by improper shipping material causing damages in transit
- Repairs made necessary by previous attempts for repair carried out by not skilled or unauthorized personnel
- Instruments for whatever reason modified by the customer himself without explicit authorization of our Service Dept
- Faults due to adaptation to a particular application not provided for by the definition of the equipment or by the instruction manual

The contents of this manual may not be reproduced in any form whatsoever without the manufacturer's authorization.

Our products are patented and our logotypes registered. We reserve the right to modify specifications and prices in view of technological improvements or developments which might be necessary.

8.2. AFTER-SALE SERVICE

Shouldn't the instrument work properly, before contacting your distributor make sure that batteries are correctly installed and working, check the test leads and replace them if necessary. Make sure that your operating procedure corresponds to the one described in this manual. Should you need for any reason to return back the instrument for repair or replacement take prior agreements with the local distributor from whom you bought it. Do not forget to enclose a report describing the reasons for returning (detected fault). Use only original packaging. Any damage occurred in transit due to not original packaging will be charged anyhow to the customer. The manufacturer will not be responsible for any damage to persons or things.