

**ENGLISH**

# User manual



**Table of contents:**

1. SAFETY PRECAUTIONS AND PROCEDURES .....	2
1.1. Preliminary .....	2
1.2. During use .....	3
1.3. After use .....	3
1.4. Measuring (overvoltage) categories definitions .....	3
2. GENERAL DESCRIPTION .....	4
3. PREPARATION FOR USE .....	4
3.1. Initial .....	4
3.2. Supply voltage .....	4
3.3. Storage .....	4
4. NOMENCLATURE .....	5
4.1. Instrument description .....	5
4.2. Description of function keys .....	5
4.2.1. HOLD key .....	5
4.2.2. Backlight key  .....	5
5. OPERATING INSTRUCTIONS .....	6
5.1. DC Voltage measurement .....	6
5.2. AC Voltage measurement .....	7
5.3. DC Current measurement .....	8
5.4. Resistance measurement .....	9
5.5. Continuity test and Diode test .....	10
5.6. Battery test .....	11
6. MAINTENANCE .....	12
6.1. Battery and fuses replacement .....	12
6.2. Cleaning .....	12
6.3. End of life .....	12
7. TECHNICAL SPECIFICATIONS .....	13
7.1. Technical features .....	13
7.1.1. Reference standards .....	14
7.1.2. General data .....	14
7.2. Environment .....	14
7.2.1. Environmental conditions .....	14
7.3. Accessories .....	14
7.3.1. Standard accessories .....	14
8. SERVICE .....	15
8.1. Warranty conditions .....	15
8.2. After-sale service .....	15

## 1. SAFETY PRECAUTIONS AND PROCEDURES

This meter is in compliance with IEC/EN61010-1 guideline related to electronic measuring instruments. For your own safety and to avoid damaging the instrument follow the procedures described in this instruction manual and read carefully all notes preceded by this symbol . When taking measurements:

- Avoid doing that in humid or wet places
- Avoid doing that in rooms where explosive gas, combustible gas, steam or excessive dust is present.
- Keep you insulated from the object under test.
- Do not touch exposed metal parts such as test lead ends, sockets, fixing objects, circuits etc.
- Avoid doing that if you notice anomalous conditions such as breakages, deformations, fractures, leakages of battery liquid, blind display etc.
- Be particularly careful when measuring voltages exceeding 20V to avoid risk of electrical shocks.

The following symbols are used on the instrument and in the manual:



CAUTION - refer to the instruction manual - an improper use may damage the instrument or its components.



Double insulated meter.



AC Voltage



DC Voltage or Current



Ground reference

### 1.1. PRELIMINARY

- This instrument has been designed for use in environments of pollution degree 2.
- It can be used for **VOLTAGE** and **DC CURRENT** measurements on installations of CAT III 600V measurement
- This instrument is not suitable for measurements of not sine wave voltage.
- When using the instrument always respect the usual safety regulations aimed at protecting you against the dangerous electric currents and protecting the instrument against incorrect operations.
- Only the leads supplied with the instrument guarantee compliance with the safety standards in force. They must be in good conditions and, if necessary, replaced with identical ones.
- Do not test or connect to any circuit exceeding the specified overload protection.
- Do not effect measurements under environmental conditions exceeding the limits indicated in § 6.2.1
- Make sure that batteries are properly installed
- Before connecting the test probes to the installation make sure that the rotary selector is positioned on the right function
- Make sure that LCD and rotary selector indicate the same function

## 1.2. DURING USE

Read the recommendations which follow and the instructions in this manual:



### CAUTION

An improper use may damage the instrument and/or its components or injure the operator.

- When changing the range, first disconnect the test leads from the circuit under test in order to avoid any accident.
- When the instrument is connected to measuring circuits never touch any unused terminal.
- When measuring resistors do not add any voltage. Although there is a protection circuit, excessive voltage could cause malfunctioning.
- If during measurement the displayed values remain constant check whether the HOLD function is active.

## 1.3. AFTER USE

- After using the instrument turn it off.
- If you expect not to use the instrument for a long period remove the battery to avoid leakages of battery liquids which may damage its inner components.

## 1.4. MEASURING (OVERVOLTAGE) CATEGORIES DEFINITIONS

IEC/EN61010-1: Safety requirements for electrical equipment for measurement, control and laboratory use, Part 1: General requirements, gives a definition of measuring category, usually called overvoltage category. § 6.7.4: Measuring circuits: (OMISSIS)

Circuits are divided into the following measurement categories:

- **Measurement category IV** is for measurements performed at the source of the low-voltage installation.  
*Examples are electricity meters and measurements on primary overcurrent protection devices and ripple control units.*
- **Measurement category III** is for measurements performed in the building installation.  
*Examples are measurements on distribution boards, circuit breakers, wiring, including cables, bus-bars, junction boxes, switches, socket-outlets in the fixed installation, and equipment for industrial use and some other equipment, for example, stationary motors with permanent connection to fixed installation.*
- **Measurement category II** is for measurements performed on circuits directly connected to the low voltage installation..  
*Examples are measurements on household appliances, portable tools and similar equipment.*
- **Measurement category I** is for measurements performed on circuits not directly connected to MAINS.  
*Examples are measurements on circuits not derived from MAINS, and specially protected (internal) MAINS-derived circuits. In the latter case, transient stresses are variable; for that reason, the norm requires that the transient withstand capability of the equipment is made known to the user.*

## 2. GENERAL DESCRIPTION

This instrument performs the below listed measurements:

- DC Voltage
- AC sine wave Voltage
- DC Current
- Resistance
- Continuity test
- Diode test
- 9V and 1.5V battery test

All function is selectable by means of a rotary selector. In addition there are the **HOLD** key to hold the displayed value and the  key for activated/disable LCD backlight.

## 3. PREPARATION FOR USE

### 3.1. INITIAL

This instrument was checked both mechanically and electrically prior to shipment. All possible cares and precautions were taken to let you receive the instrument in perfect conditions. Notwithstanding we suggest you to check it rapidly (eventual damages may have occurred during transport – if so please contact the local distributor from whom you bought the item).

Make sure that all standard accessories mentioned in § 7.3.1 are included. Should you have to return back the instrument for any reason please follow the instructions mentioned in § 8.

### 3.2. SUPPLY VOLTAGE

The instrument is supplied by 1x9V battery type IEC 6F22. When battery are low, a low battery indication "" is displayed. To replace/insert battery please refer to § 6.1.

### 3.3. STORAGE

After a period of storage under extreme environmental conditions exceeding the limits mentioned in § 7.2.1 let the instrument resume normal measuring conditions before using it.

## 4. NOMENCLATURE

### 4.1. INSTRUMENT DESCRIPTION

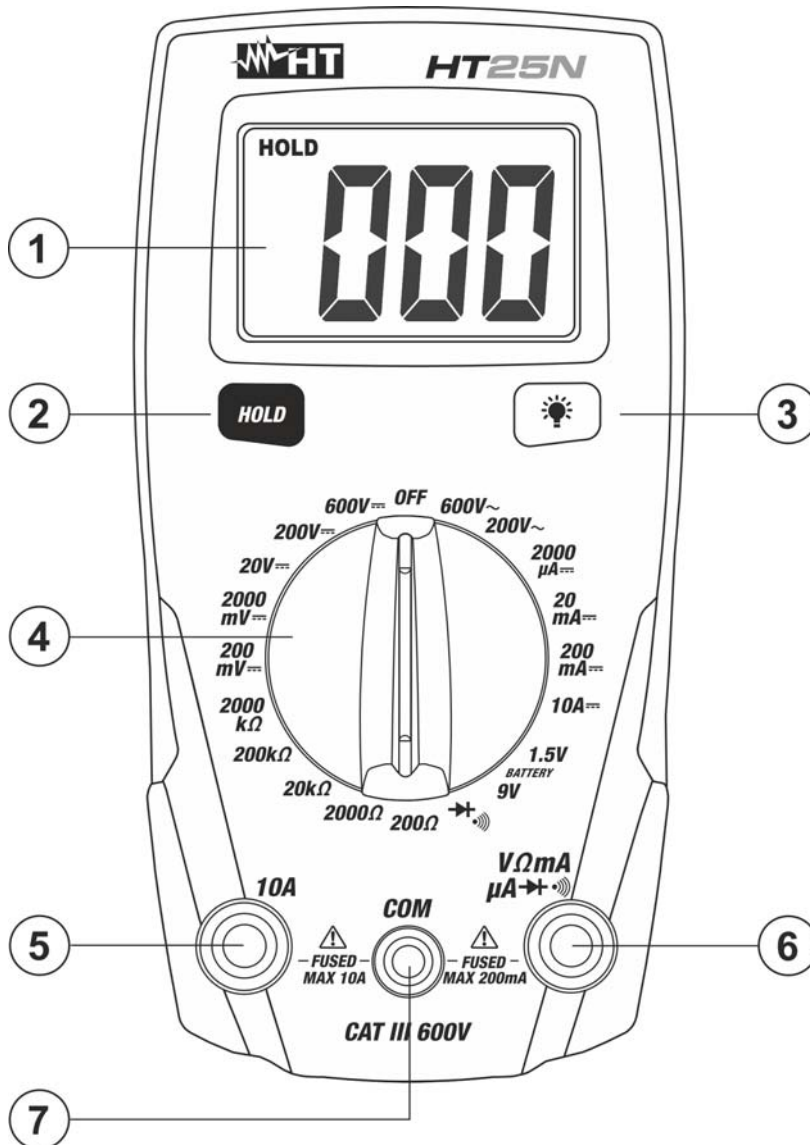

#### CAPTION:

1. LCD display
2. **HOLD** key
3. **Backlight** key
4. Function selector
5. Input terminal **10A**
6. Input terminal **V $\Omega$ mA $\mu$ A**
7. Input terminal **COM**

Fig. 1: Instrument description

## 4.2. DESCRIPTION OF FUNCTION KEYS

### 4.2.1. HOLD key

By pressing **HOLD** key the measured value is frozen on the display where the symbol "HOLD" appears. Press again **HOLD** to disable this function and resume normal operation.

### 4.2.2. Backlight key

By pressing key it's possible to activate/disabled the backlight function on the display.

## 5. OPERATING INSTRUCTIONS

### 5.1. DC VOLTAGE MEASUREMENT

#### CAUTION



The maximum input for DC voltage is 600V. Do not attempt to measure higher voltages to avoid electrical shocks or damages to the instrument.



Fig. 2: Using the meter for DC Voltage measurement

1. Selecting the position **200mV $\overline{=}$** , **2000mV $\overline{=}$** , **20V $\overline{=}$** , **200V $\overline{=}$**  or **600V $\overline{=}$**
2. Insert the test leads into the jacks, the red plug into **V $\Omega$ mA $\mu$ A $\rightarrow$**  jack and black plug into **COM** jack
3. Connect the red and black test leads to the positive and negative poles of the circuit under test respectively (see Fig. 2). The voltage value is displayed
4. If the message "**OL**" is displayed select a higher range.
5. The symbol "-" on the instrument display indicates that voltage has opposite direction with regard to the connection.
6. For HOLD function refer to § 4.2.1

## 5.2. AC VOLTAGE MEASUREMENT

### CAUTION



The maximum input for AC voltage is 600V. Do not attempt to measure higher voltages to avoid electrical shocks or damages to the instrument.



Fig. 3: Using the instrument for AC Voltage measurement

1. Selecting the position **200V~** or **600V~**
2. Insert the test leads into the jacks, the red plug into **VΩmAμA** jack and black plug into **COM** jack
3. Connect the test leads to the circuit under test (see Fig. 3). The voltage value is displayed
4. If the message "**OL**" is displayed select a higher range.
5. For HOLD function refer to § 4.2.1

### 5.3. DC CURRENT MEASUREMENT

#### CAUTION



The maximum input for DC current is 10A (**10A** input) or 200mA (**VΩmAμA** input). Do not attempt to measure higher currents to avoid electrical shocks or damages to the instrument.

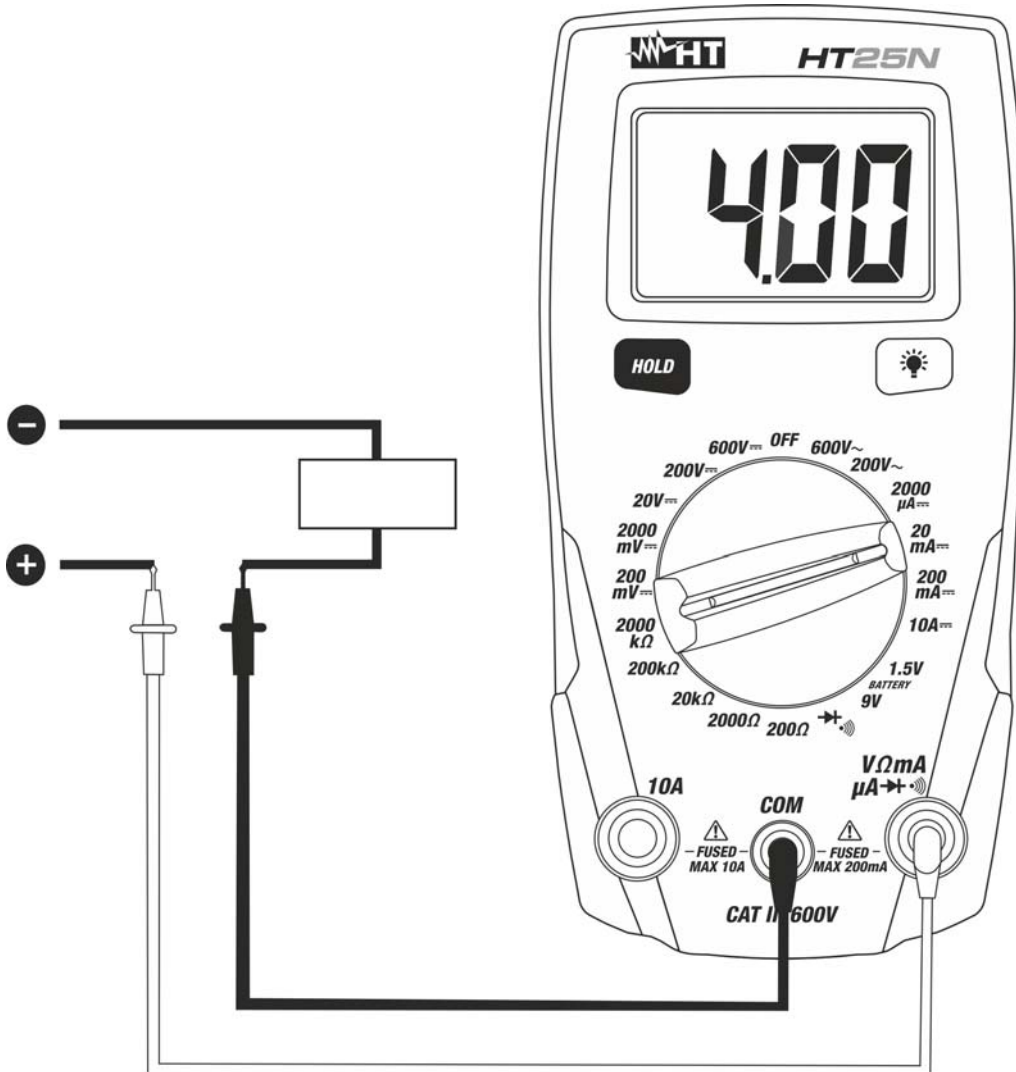

Fig. 4: Using the instrument for DC Current measurement

1. Power off the circuit under test
2. Selecting the position **2000μA**, **20mA**, **200mA** or **10A**
3. Insert the test leads into the jacks, the red plug into **10A** jack or **VΩmAμA** jack and black plug into **COM** jack
4. Connect the red and the black plugs in series with the circuit whose current is to be measured respecting the polarities (see Fig. 4)
5. Energize the circuit under test. The current value will be displayed.
6. The message "**OL**" means that the detected current exceeds the limits.
7. The symbol "-" on the instrument display indicates that voltage has opposite direction with regard to the connection.
8. For HOLD function refer to § 4.2.1

## 5.4. RESISTANCE MEASUREMENT

### CAUTION



Before taking resistance measurements on the circuit remove power from the circuit being tested and discharge all capacitors.

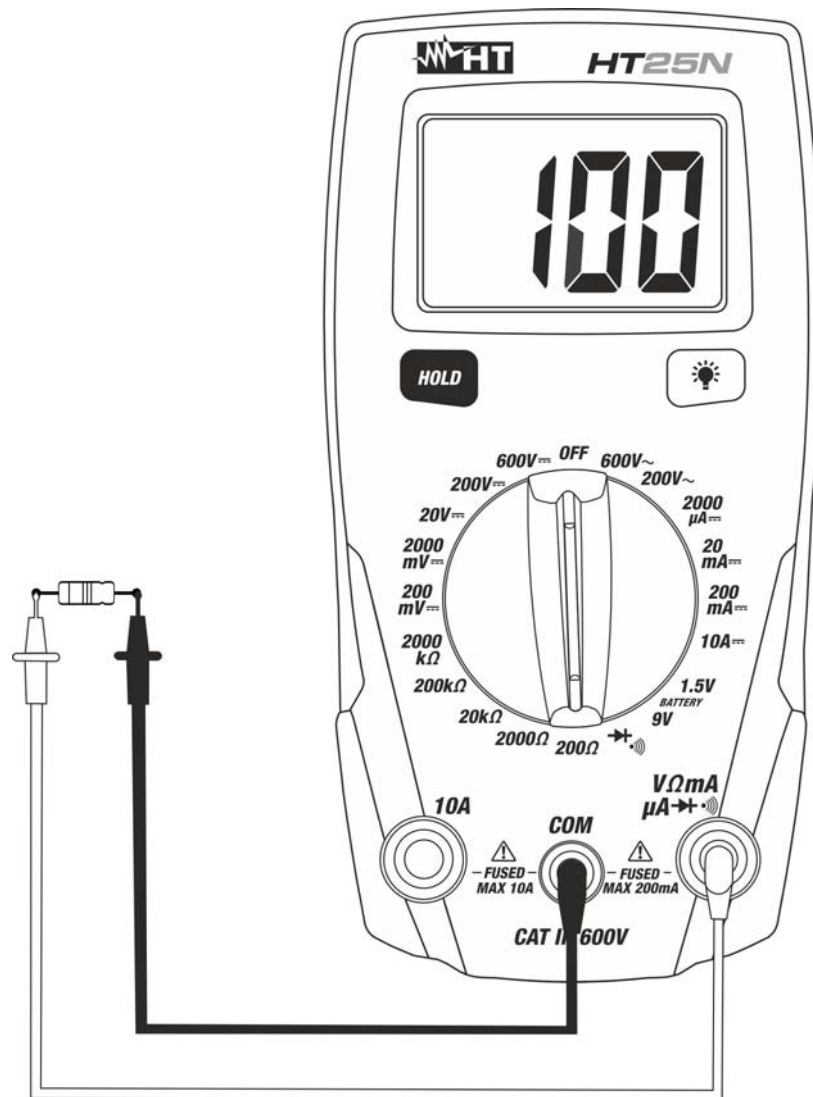

Fig. 5: Using the instrument for Resistance measurement

1. Selecting the position **200Ω, 2000Ω, 20kΩ, 200kΩ or 2000kΩ**
2. Insert the test leads into the jack, the red plug into **VΩmAμA** jack and black plug into **COM** jack
3. Connect the test leads to the circuit under test (see Fig. 5). The resistance value is displayed
4. If the message "**OL**" is displayed a higher range must be selected
5. For HOLD function refer to § 4.2.1

## 5.5. CONTINUITY TEST AND DIODE TEST

### CAUTION



Before taking resistance measurements on the circuit remove power from the circuit being tested and discharge all capacitors.

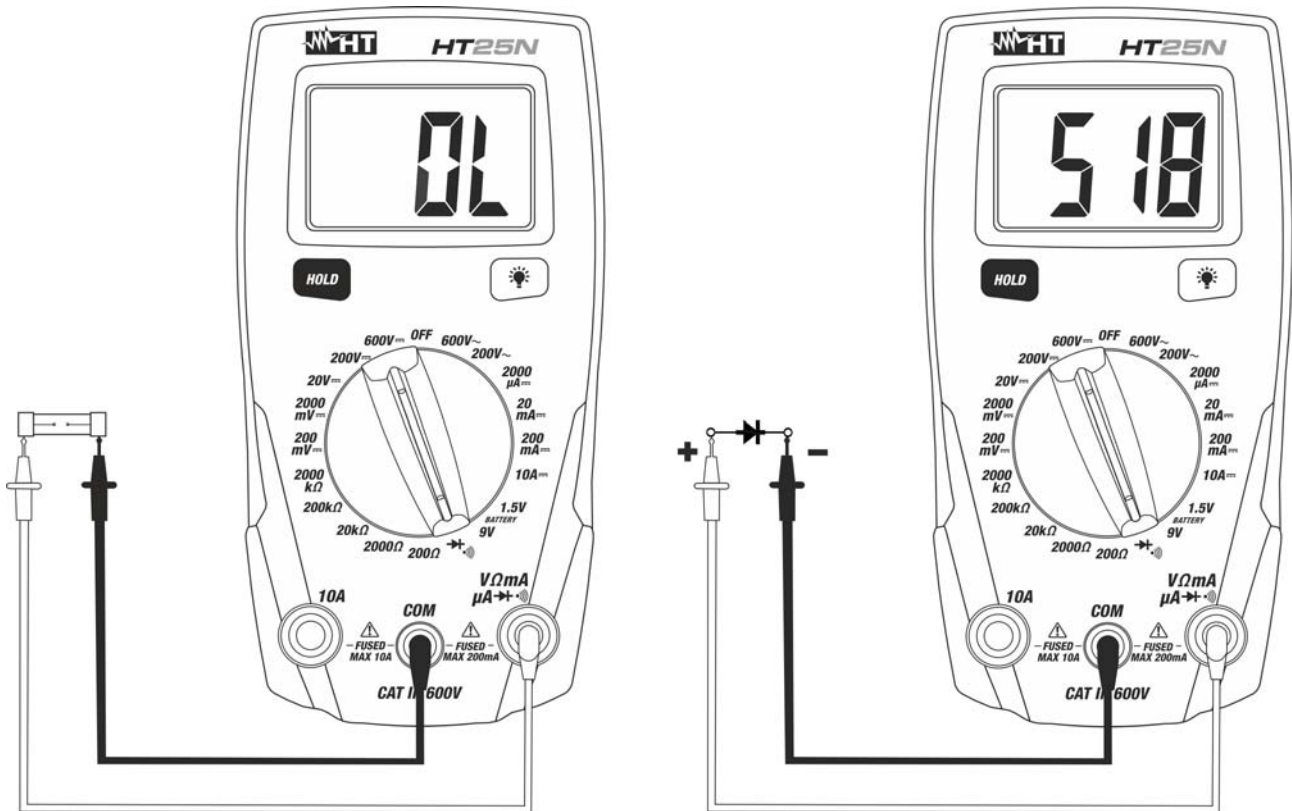

Fig. 6: Using the instrument for Continuity test and Diode test

1. Selecting the position  $\rightarrow \text{diode symbol}$ )
2. Insert the test leads into the jacks, the red plug into **VΩmAμA**  $\rightarrow \text{diode symbol}$ ) jack and black plug into **COM** jack

#### Continuity test

3. Connect the test leads to the circuit under test (see Fig. 6 – left part)
4. The resistance value (just indicative) is displayed and the instrument emits a sound signal if the resistance value results to be  $<60\Omega$

#### Diode test

5. Connect the test leads to the diode under test observing the proper polarities (see Fig. 6 – right part)
6. The threshold voltage value of direct polarization, expressed in **mV** is shown at display
7. If the threshold voltage value is **0V** the diode P-N junction is shorted circuit
8. If the message "**OL**" is displayed the diode terminals are reversed, the diode P-N junction is damaged

## 5.6. BATTERY TEST

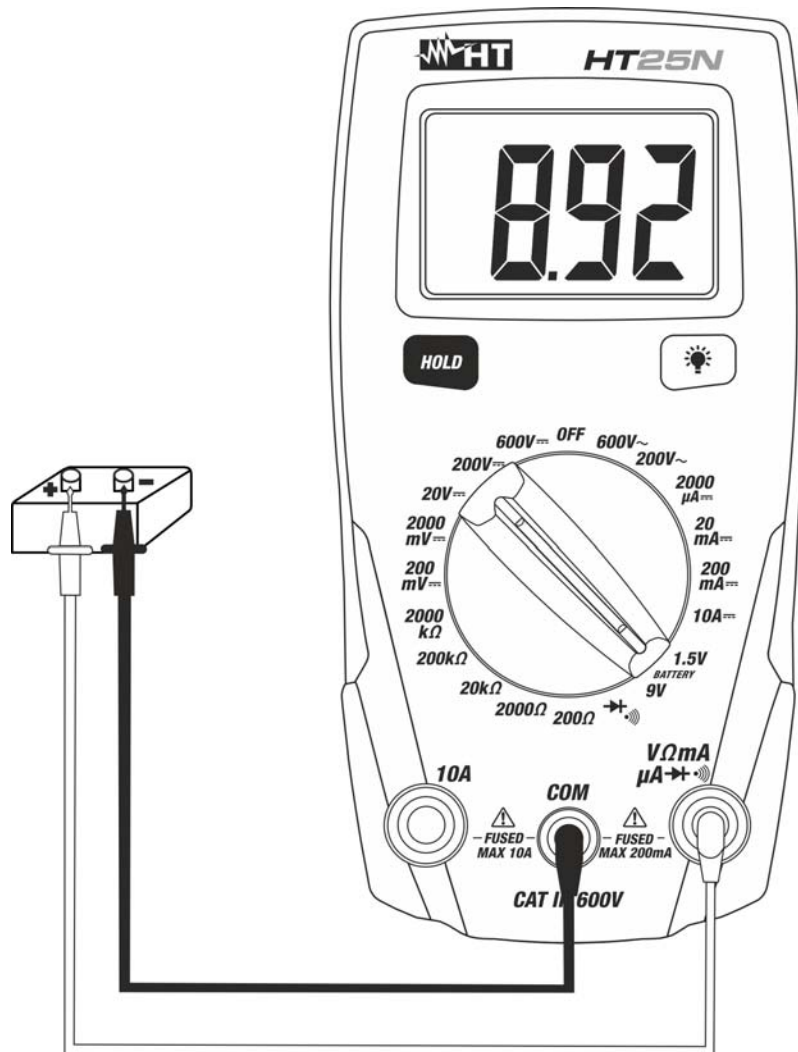

Fig. 7: Using the instrument for Battery test

1. Selecting the position **1.5V** (1.5V battery test) or **9V** (9V battery test)
2. Insert the test leads into the jacks, the red plug into **VΩmAμA** jack, and black plug into **COM** jack
3. Connect the red and black test leads to the positive and negative poles of the battery under test respectively (see Fig. 7). The battery voltage value is displayed
4. For HOLD function refer to § 4.2.1

## 6. MAINTENANCE



### CAUTION

- Only skilled technicians can open the instrument and replace batteries. Before removing batteries disconnect the test leads from the input terminals to avoid electrical shocks
- Do not expose it to high temperatures or humidity or direct sunlight
- Be sure to turn it off after use. If you expect not to use the instrument for a long period remove batteries to avoid leakages of battery liquid which could damage its inner components

### 6.1. BATTERY AND FUSES REPLACEMENT

When the low battery indication ""

#### Battery replacement

1. Turn off the instrument
2. Disconnect the test leads from the input terminals.
3. Remove the fixing screw from the battery cover and detach it.
4. Remove the battery replacing it with new one of the same type (see § 7.1.2) respecting the polarity signs.
5. Replace the battery cover and screw
6. Use the appropriate battery disposal methods for your area.

#### Fuses replacement

1. Turn OFF the meter and disconnect the test leads from the input terminals
2. Unscrew the four fixing screws of the back holster and remove it
3. Remove the defective fuse and install a new fuse of the same size and rating (see § 7.1.2) Make sure the new fuse is centered in the fuse holder. Re-screw the back holster

### 6.2. CLEANING

To clean the instrument use a soft dry cloth. Never use a wet cloth, solvents or water.

### 6.3. END OF LIFE



**CAUTION:** this symbol indicates that equipment and its accessories shall be subject to a separate collection and correct disposal.

## 7. TECHNICAL SPECIFICATIONS

### 7.1. TECHNICAL FEATURES

Accuracy is calculated as  $\pm[\%rdg + (\text{num. digits} \times \text{resolution})]$  at  $18^{\circ}\text{C} \div 28^{\circ}\text{C}$ ,  $< 75\%HR$

#### DC Voltage

Range	Resolution	Accuracy	Input impedance	Overload protection
200.0mV	0.1mV	$\pm(0.7\%rdg + 3dgt)$	$>1M\Omega$	200Vrms
2000mV	1mV			600V DC/AC
20.00V	0.01V			
200.0V	0.1V	$\pm(1.0\%rdg + 3dgt)$		
600V	1V			

#### AC Voltage

Range	Resolution	Accuracy (50÷60Hz)	Input impedance	Overload protection
200.0V	0.1V	$\pm(1.5\%rdg + 12dgt)$	$>1M\Omega$	600V DC/AC
600V	1V			

#### DC Current

Range	Resolution	Accuracy	Internal voltage drop	Overload protection
2000 $\mu$ A	1 $\mu$ A	$\pm(1.5\%rdg + 3dgt)$	200mV	Fast fuse 200mA / 600V
20.00mA	0.01mA			
200.0mA	0.1mA			
10.00A	0.01A	$\pm(2.5\%rdg + 2dgt)$		Fast fuse 10A / 600V

#### Resistance and Continuity test

Range	Resolution	Accuracy	Buzzer	Overload protection
200.0 $\Omega$	0.1 $\Omega$	$\pm(1.2\%rdg + 4dgt)$	$<60\Omega$	250Vrms $<15\text{sec}$
2000 $\Omega$	1 $\Omega$			
20.00k $\Omega$	0.01k $\Omega$			
200.0k $\Omega$	0.1k $\Omega$			
2000k $\Omega$	1k $\Omega$	$\pm(1.5\%rdg + 2dgt)$		

#### Diode test

Function	Test current	Max open circuit voltage
	approx 1mA	circa 1.2V

#### Battery test

Range	Resolution	Accuracy	Test current
1.5V	1mV	$\pm(1.5\%rdg + 3dgt)$	100mA
9V	10mV		6mA

### 7.1.1. Reference standards

Safety:	IEC/EN61010-1
EMC:	IEC/EN61326-1
Insulation:	double insulation
Pollution degree:	2
Measurement category:	CAT III 600V
Max height of use:	2000m (6561ft)

### 7.1.2. General data

#### Mechanical characteristics

Dimensions (L x W x H):	150 x 70 x 48mm (6 x 3 x 2in)
Weight (including battery):	255g (9 ounces)
Mechanical protection:	IP40

#### Power supply

Battery type:	1x9V battery type NEDA 1604 IEC 6F22
Battery life:	ca 30h (backlight ON), ca 130h (backlight OFF)
Low battery indication:	symbol "  " is displayed
Fuses:	F10A/600V, 5 x 20mm ( <b>10A</b> input) F200mA/600V, 5 x 20mm ( <b>mA<math>\mu</math>A</b> input)

#### Display

Specifications:	3½ LCD with max. reading 2000 counts + sign and decimal point, backlight
-----------------	--

## 7.2. ENVIRONMENT

### 7.2.1. Environmental conditions

Reference temperature:	18°C ÷ 28°C (64°F ± 82°F)
Working temperature:	0°C ÷ 50°C (32°F ÷ 122°F)
Relative humidity:	<70%HR
Storage temperature:	-20°C ÷ 60°C (-4°F ÷ 140°F)
Storage humidity:	<80%HR

**This instrument satisfies the requirements of Low Voltage Directive 2014/35/EU (LVD) and of EMC Directive 2014/30/EU**

**This instrument satisfies the requirements of 2011/65/EU (RoHS) directive and 2012/19/EU (WEEE) directive**

## 7.3. ACCESSORIES

### 7.3.1. Standard accessories

- Test leads
- User manual
- Battery

## 8. SERVICE

### 8.1. WARRANTY CONDITIONS

This instrument is guaranteed against material or production defects, in accordance with our general sales conditions. During the warranty period the manufacturer reserves the right to decide either to repair or replace the product. Should you need for any reason to return back the instrument for repair or replacement take prior agreements with the local distributor from whom you bought it. Do not forget to enclose a report describing the reasons for returning (detected fault). Use only original packaging. Any damage occurred in transit due to no original packaging will be charged anyhow to the customer. The manufacturer will not be responsible for any damage to persons or things.

The warranty doesn't apply to:

- Accessories and batteries (not covered by warranty).
- Repairs made necessary by improper use (including adaptation to particular applications not provided in the instructions manual) or improper combination with incompatible accessories or equipment.
- Repairs made necessary by improper shipping material causing damages in transit.
- Repairs made necessary by previous attempts for repair carried out by unskilled or unauthorized personnel.
- Instruments for whatever reason modified by the customer himself without explicit authorization of our Technical Dept.
- Adaptation to a particular application not provided for by the definition of the equipment or by the instruction manual

The contents of this manual may not be reproduced in any form whatsoever without the manufacturer's authorization.

**Our products are patented and our logotypes registered. We reserve the right to modify specifications and prices in view of technological improvements or developments which might be necessary.**

### 8.2. AFTER-SALE SERVICE

Shouldn't the instrument work properly, before contacting your distributor make sure that batteries are correctly installed and working, check the test leads and replace them if necessary. Make sure that your operating procedure corresponds to the one described in this manual. Should you need for any reason to return back the instrument for repair or replacement take prior agreements with the local distributor from whom you bought it. Do not forget to enclose a report describing the reasons for returning (detected fault). Use only original packaging. Any damage occurred in transit due to not original packaging will be charged anyhow to the customer. The manufacturer will not be responsible for any damage to persons or things.