

ENGLISH

User manual



TABLE OF CONTENTS

1. PRECAUTIONS AND SAFETY MEASURES	2
1.1. Preliminary instructions	2
1.2. During use	3
1.3. After use	3
1.4. Definition of Measurement (Overvoltage) category	3
2. GENERAL DESCRIPTION	4
2.1. Measuring average values and TRMS values	4
2.2. Definition of true root mean square value and Crest factor	4
3. PREPARATION FOR USE	5
3.1. Initial checks	5
3.2. Instrument power supply	5
3.3. Storage	5
4. NOMENCLATURE	6
4.1. Description of the instrument	6
4.2. Description of function keys	7
4.2.1. AUTO HOLD key	7
4.2.2. RANGE key	7
4.2.3. MAX MIN/PEAK key	7
4.2.4. Hz%/REL Δ key	7
4.2.5. MODE key	8
4.2.6. HIREs/  key	8
4.2.7. LoZ feature	8
4.2.8. AC+DC feature	8
4.2.9. LEAD message at display	8
4.2.10. Disabling the Auto Power Off function	8
5. OPERATING INSTRUCTIONS	9
5.1. DC Voltage measurement	9
5.2. AC, AC+DC Voltage measurement	10
5.3. AC, DC, AC+DC Voltage measurement with low impedance (LoZ)	11
5.4. Frequency and Duty Cycle measurement	12
5.5. Resistance measurement and Continuity test	13
5.6. Diode test	14
5.7. Capacitance measurement	15
5.8. Temperature measurement with K-type probe	16
5.9. DC Current measurement and e 4-20mA% reading	17
5.10. AC, AC+DC Current measurement	18
5.11. AC, DC, AC+DC Current measurement with transducer clamps	19
6. MAINTENANCE	20
6.1. Replacing the batteries and the internal fuses	20
6.2. Cleaning the instrument	20
6.3. End of life	20
7. TECHNICAL SPECIFICATIONS	21
7.1. Technical characteristics	21
7.1.1. Reference standards	23
7.1.2. General characteristics	24
7.2. Environment	24
7.2.1. Environmental conditions for use	24
7.3. Accessories	24
7.3.1. Accessories provided	24
7.3.2. Optional accessories	24
8. ASSISTANCE	25
8.1. Warranty conditions	25
8.2. Assistance	25

1. PRECAUTIONS AND SAFETY MEASURES

The instrument has been designed in compliance with directive IEC/EN61010-1 relevant to electronic measuring instruments. For your safety and in order to prevent damaging the instrument, please carefully follow the procedures described in this manual and read all notes preceded by symbol  with the utmost attention.

Before and after carrying out measurements, carefully observe the following instructions:

- Do not carry out any measurement in humid environments.
- Do not carry out any measurements in case gas, explosive materials or flammables are present, or in dusty environments.
- Avoid any contact with the circuit being measured if no measurements are being carried out.
- Avoid any contact with exposed metal parts, with unused measuring probes, circuits, etc.
- Do not carry out any measurement in case you find anomalies in the instrument such as deformation, breaks, substance leaks, absence of display on the screen, etc.
- Pay special attention when measuring voltages higher than 20V, since a risk of electrical shock exists.

In this manual, and on the instrument, the following symbols are used:



Warning: observe the instructions given in this manual; improper use could damage the instrument or its components.



Double-insulated meter



AC voltage or current



DC voltage or current



Connection to earth

1.1. PRELIMINARY INSTRUCTIONS

- This instrument has been designed for use in environments of pollution degree 2.
- It can be used for **VOLTAGE** and **CURRENT** measurements on installations with CAT IV 600V and CAT III 1000V.
- We recommend following the normal safety rules devised by the procedures for carrying out operations on live systems and using the prescribed PPE to protect the user against dangerous currents and the instrument against incorrect use.
- In case the lack of indication of the presence of voltage may represent a danger for the operator, always carry out a continuity measurement before carrying out the measurement on the live system, in order to confirm the correct connection and condition of the leads.
- Only the leads supplied with the instrument guarantee compliance with the safety standards. They must be in good conditions and be replaced with identical models, when necessary.
- Do not test circuits exceeding the specified voltage limits.
- Do not perform any test under environmental conditions exceeding the limits indicated in § 6.2.1.
- Check that the battery is correctly inserted.
- Make sure that the LCD display and the rotary switch indicate the same function.

1.2. DURING USE

Please carefully read the following recommendations and instructions:



CAUTION

Failure to comply with the caution notes and/or instructions may damage the instrument and/or its components or be a source of danger for the operator.

- Before activating the rotary switch, disconnect the test leads from the circuit being measured.
- When the instrument is connected to the circuit being measured, do not touch any unused terminal.
- Do not measure resistance in case external voltages are present; even if the instrument is protected, an excessive voltage may cause malfunction.
- While measuring, if the value or the sign of the quantity being measured remain unchanged, check if the HOLD function is enabled.

1.3. AFTER USE

- When measurement is complete, set the rotary switch to OFF to turn off the instrument.
- If the instrument is not to be used for a long time, remove the batteries.

1.4. DEFINITION OF MEASUREMENT (OVERVOLTAGE) CATEGORY

Standard "IEC/EN61010-1: Safety requirements for electrical equipment for measurement, control and laboratory use, Part 1: General requirements", defines what measurement category, commonly called overvoltage category, is. § 6.7.4: Measured circuits, reads:

(OMISSIS)

Circuits are divided into the following measurement categories:

- **Measurement category IV** is for measurements performed at the source of the low-voltage installation.
Examples are electricity meters and measurements on primary overcurrent protection devices and ripple control units.
- **Measurement category III** is for measurements performed on installations inside buildings.
Examples are measurements on distribution boards, circuit breakers, wiring, including cables, bus-bars, junction boxes, switches, socket-outlets in the fixed installation, and equipment for industrial use and some other equipment, for example, stationary motors with permanent connection to fixed installation.
- **Measurement category II** is for measurements performed on circuits directly connected to the low-voltage installation.
Examples are measurements on household appliances, portable tools and similar equipment.
- **Measurement category I** is for measurements performed on circuits not directly connected to MAINS.
Examples are measurements on circuits not derived from MAINS, and specially protected (internal) MAINS-derived circuits. In the latter case, transient stresses are variable; for that reason, the standard requires that the transient withstand capability of the equipment is made known to the user.

2. GENERAL DESCRIPTION

The instrument carries out the following measurements:

- DC Voltage
- AC, AC+DC TRMS Voltage
- DC, AC, AC+DC voltage with low impedance (LoZ)
- DC Current
- AC, AC+DC TRMS Current
- AC, AC+DC TRMS Current with transducer clamps
- 4-20mA% display
- Resistance and Continuity test
- Diode test
- Capacity
- Current and voltage frequency
- Duty Cycle
- Temperature with K-type probe

Each of these functions can be selected by means of the appropriate switch. The instrument is also equipped with function keys (see § 4.2), an analogue bargraph and backlight. The instrument is also equipped with an Auto Power OFF function (which can be disabled), which automatically switches off the instrument 15 minutes after the last time a function key was pressed or the rotary switch was turned. To switch on the instrument again, turn the rotary switch.

2.1. MEASURING AVERAGE VALUES AND TRMS VALUES

Measuring instruments of alternating quantities are divided into two big families:

- AVERAGE-VALUE meters: instruments measuring the value of the sole wave at fundamental frequency (50 or 60 Hz).
- TRMS (True Root Mean Square) VALUE meters: instruments measuring the TRMS value of the quantity being tested.

With a perfectly sinusoidal wave, the two families of instruments provide identical results. With distorted waves, instead, the readings shall differ. Average-value meters provide the RMS value of the sole fundamental wave; TRSM meters, instead, provide the RMS value of the whole wave, including harmonics (within the instruments bandwidth). Therefore, by measuring the same quantity with instruments from both families, the values obtained are identical only if the wave is perfectly sinusoidal. In case it is distorted, TRMS meters shall provide higher values than the values read by average-value meters.

2.2. DEFINITION OF TRUE ROOT MEAN SQUARE VALUE AND CREST FACTOR

The root mean square value of current is defined as follows: *"In a time equal to a period, an alternating current with a root mean square value of 1A intensity, circulating on a resistor, dissipates the same energy that, during the same time, would be dissipated by a direct current with an intensity of 1A"*. This definition results in the numeric expression:

$$G = \sqrt{\frac{1}{T} \int_{t_0}^{t_0+T} g^2(t) dt}$$

The root mean square value is indicated with the acronym RMS.

The Crest Factor is defined as the relationship between the Peak Value of a signal and its

RMS value: $CF (G) = \frac{G_p}{G_{RMS}}$ This value changes with the signal waveform, for a purely

sinusoidal wave it is $\sqrt{2} = 1.41$. In case of distortion, the Crest Factor takes higher values as wave distortion increases.

3. PREPARATION FOR USE

3.1. INITIAL CHECKS

Before shipping, the instrument has been checked from an electric as well as mechanical point of view. All possible precautions have been taken so that the instrument is delivered undamaged.

However, we recommend generally checking the instrument in order to detect possible damage suffered during transport. In case anomalies are found, immediately contact the forwarding agent.

We also recommend checking that the packaging contains all components indicated in § 6.3.1. In case of discrepancy, please contact the Dealer.

In case the instrument should be returned, please follow the instructions given in § 7.

3.2. INSTRUMENT POWER SUPPLY

The instrument is supplied with 4x1.5V alkaline batteries type AAA IEC LR03, included in the package. When batteries are flat, the symbol  appears on the display. To replace the batteries, see § 6.1.

3.3. STORAGE

In order to guarantee precise measurement, after a long storage time under extreme environmental conditions, wait for the instrument to come back to normal condition (see § 6.2.1).

4. NOMENCLATURE

4.1. DESCRIPTION OF THE INSTRUMENT

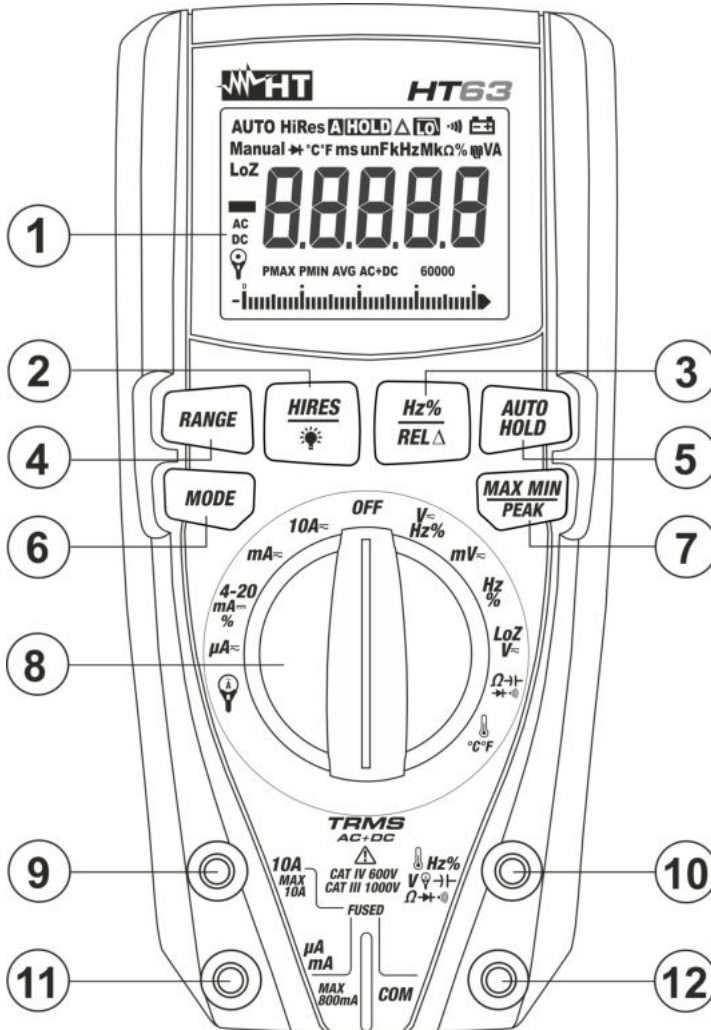

CAPTION:

1. LCD display
2. **HIRES/** key
3. **Hz%/REL** key
4. **RANGE** key
5. **AUTO HOLD** key
6. **MODE** key
7. **MAX MIN PEAK** key
8. Rotary selector switch
9. Input terminal **10A**
10. Input terminal
11. Input terminal **mA μ A**
12. Input terminal **COM**

Fig. 1: Description of the instrument

5. OPERATING INSTRUCTIONS

5.1. DC VOLTAGE MEASUREMENT



CAUTION

The maximum input DC voltage is 1000V. Do not measure voltages exceeding the limits given in this manual. Exceeding voltage limits could result in electrical shocks to the user and damage to the instrument.



Fig. 2: Use of the instrument for DC Voltage measurement

1. Select positions $V \sim \text{Hz}\%$ or $mV \sim$
2. Insert the red cable into input terminal $\text{Hz}\% \text{ V} \rightarrow \Omega \rightarrow \text{mA} \rightarrow \mu\text{A}$ and the black cable into input terminal **COM**.
3. Position the red lead and the black lead respectively in the spots with positive and negative potential of the circuit to be measured (see Fig. 2). The display shows the value of voltage.
4. If the display shows the message "O.L", select a higher range.
5. When symbol "-" appears on the instrument's display, it means that voltage has the opposite direction with respect to the connection in Fig. 2.
6. To use the HOLD, RANGE, MAX MIN, REL Δ and HIRES functions, see § 4.2

5.2. AC, AC+DC VOLTAGE MEASUREMENT

CAUTION



The maximum input AC voltage is 1000V. Do not measure voltages exceeding the limits given in this manual. Exceeding voltage limits could result in electrical shocks to the user and damage to the instrument.



Fig. 3: Use of the instrument for AC voltage measurement

1. Select positions $V \sim \text{Hz}\%$ or $mV \sim$
2. Press the **MODE** key to display the "AC" or "AC+DC" symbol on the display
3. Insert the red cable into input terminal $\text{Hz}\% \text{ V} \sim \text{Hz}\% \text{ V} \sim \text{Hz}\% \text{ V} \sim \text{Hz}\%$ and the black cable into input terminal **COM**.
4. Position the red lead and the black lead respectively in the spots of the circuit to be measured (see Fig. 3). The display shows the value of voltage.
5. If the display shows the message "O.L", select a higher range.
6. Press the **Hz%/REL** key to select measurements "Hz" or "%" in order to display the values of frequency and duty cycle of input voltage. The bargraph is not active in these functions. Press the **MODE** key to go back to voltage measurement and activate the function, if necessary.
7. To use the HOLD, RANGE, MAX MIN, PEAK, HIRES and REL functions, see § 4.2

5.3. AC, DC, AC+DC VOLTAGE MEASUREMENT WITH LOW IMPEDANCE (LOZ)



CAUTION

The maximum input AC/DC voltage is 600V. Do not measure voltages exceeding the limits given in this manual. Exceeding voltage limits could result in electrical shocks to the user and damage to the instrument.



Fig. 4: Use of the instrument for AC/DC voltage measurement with low impedance (LoZ)

1. Select position **LoZV~**. The “LoZ” and “DC” symbols are shown
2. Press the **MODE** key to select possibly the “AC” or “AC+DC” measurement
3. Insert the red cable into input terminal **Hz% V~** and the black cable into input terminal **COM**
4. Position the red lead and the black lead respectively in the desired spots of the circuit to be measured (see Fig. 4) or in the spots with positive and negative potential of the circuit to be measured (see Fig. 2). The display shows the value of voltage.
5. The message “**O.L.**” indicates that the value of DC voltage exceeds the maximum measurable value.
6. When symbol “-” appears on the instrument’s display, it means that voltage has the opposite direction with respect to the connection in Fig. 2
7. To use the HOLD, RANGE, MAX MIN, PEAK, HIRES and REL functions, see § 4.2

5.4. FREQUENCY AND DUTY CYCLE MEASUREMENT

CAUTION



The maximum input AC voltage is 1000V. Do not measure voltages exceeding the limits given in this manual. Exceeding voltage limits could result in electrical shocks to the user and damage to the instrument.

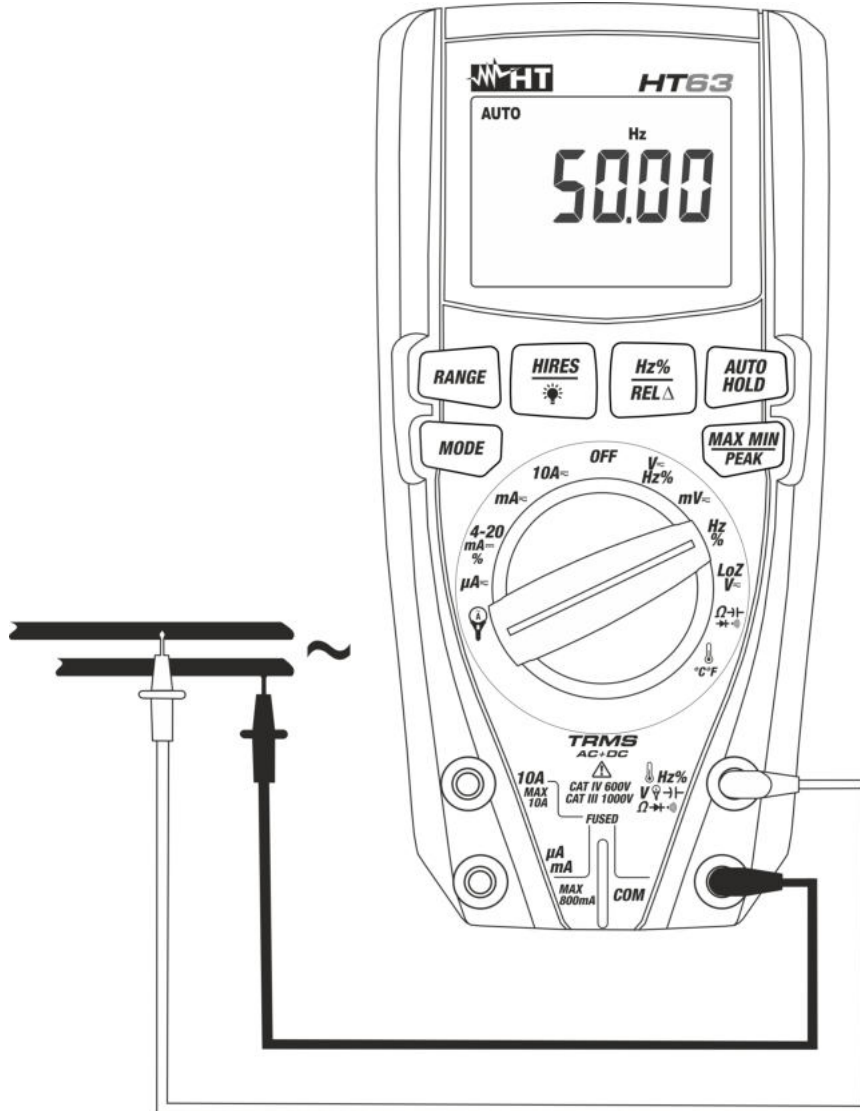

Fig. 5: Use of the instrument for frequency measurement and duty cycle test.

1. Select position **Hz%**.
2. Press the **Hz%/REL** key to select measurements "Hz" or "%" in order to display the values of frequency and duty cycle of input voltage.
3. Insert the red cable into input terminal **Hz%** and the black cable into input terminal **COM**.
4. Position the red lead and the black lead respectively in the spots of the circuit to be measured (see Fig. 5). The value of frequency (Hz) or of duty cycle (%) is shown on the display. The bargraph is not active in these functions.
5. If the display shows the message "O.L.", select a higher range.
6. To use the HOLD and HIRES function, see § 4.2.

5.5. RESISTANCE MEASUREMENT AND CONTINUITY TEST
CAUTION

Before attempting any resistance measurement, cut off power supply from the circuit to be measured and make sure that all capacitors are discharged, if present.

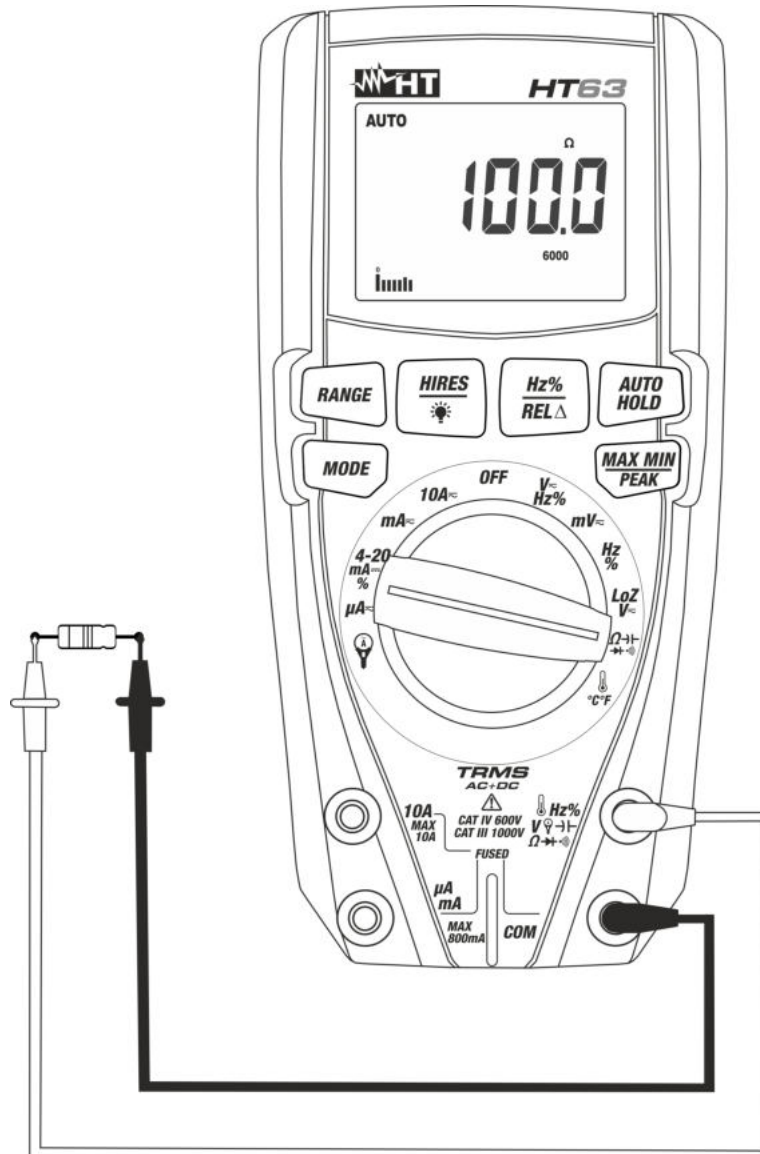

Fig. 6: Use of the instrument for Resistance measurement and Continuity test

1. Select position $\Omega \rightarrow \rightarrow \rightarrow$
2. Insert the red cable into input terminal $\Omega \rightarrow \rightarrow \rightarrow$ and the black cable into input terminal **COM**.
3. Position the test leads in the desired spots of the circuit to be measured (see Fig. 6). The display shows the value of resistance.
4. If the display shows the message "O.L", select a higher range.
5. Press the **MODE** key to select $\rightarrow \rightarrow \rightarrow$ measurement, relevant to the continuity test, and position the test leads in the desired spots of the circuit to be measured.
6. The value of resistance (which is only indicative) is displayed in Ω and the instrument sounds if the value of resistance is $<35.\Omega$
7. To use the HOLD, RANGE, MAX MIN, REL Δ and HIRES functions, see § 4.2

5.6. DIODE TEST

CAUTION

Before attempting any resistance measurement, cut off power supply from the circuit to be measured and make sure that all capacitors are discharged, if present.

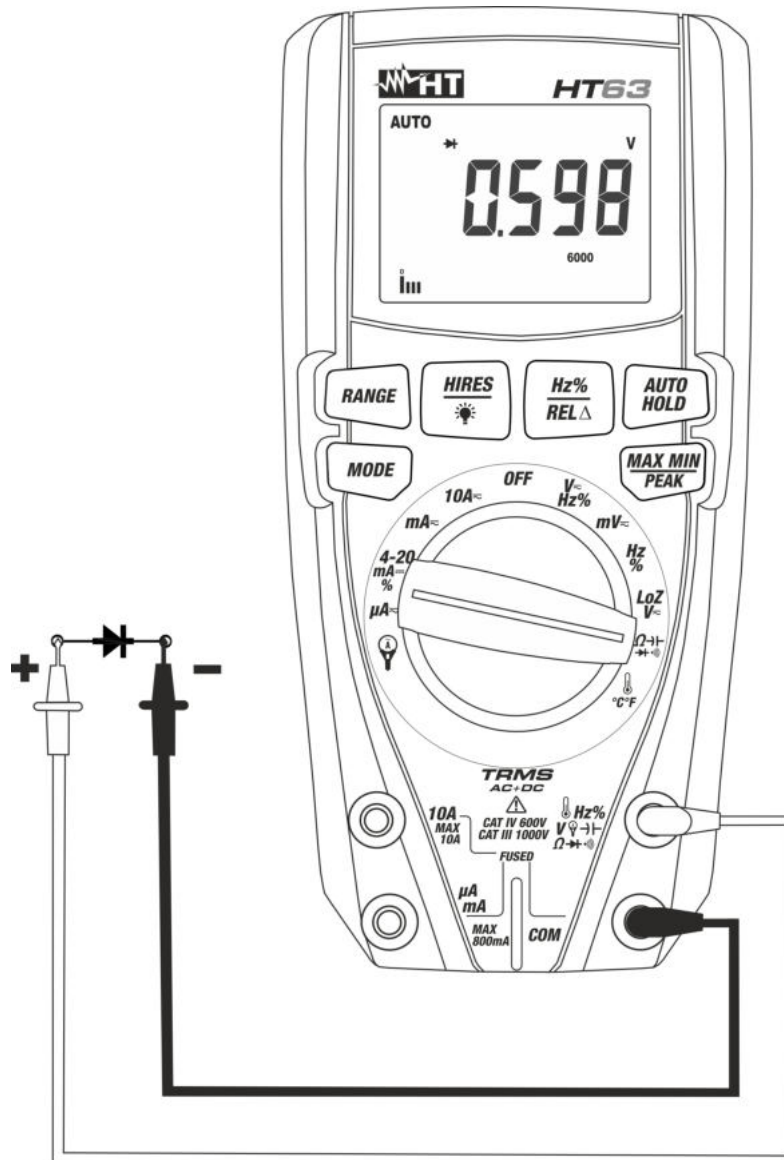

Fig. 7: Use of the instrument for diode test

1. Select position $\Omega \rightarrow \text{diode symbol}$
2. Press the **MODE** key to select “ \rightarrow ” measurement.
3. Insert the red cable into input terminal $\text{Hz}\% \text{V}\rightarrow \text{diode symbol}$ and the black cable into input terminal **COM**.
4. Position the leads at the ends of the diode to be tested (see Fig. 7), respecting the indicated polarity. The value of directly polarized threshold voltage is shown on the display.
5. If threshold value is equal to 0mV, the P-N junction of the diode is short-circuited.
6. If the display shows the message “O.L”, the terminals of the diode are reversed with respect to the indication given in Fig. 7 or the P-N junction of the diode is damaged.
7. To use the HOLD and HIRES function, see § 4.2.

5.8. TEMPERATURE MEASUREMENT WITH K-TYPE PROBE



CAUTION

Before attempting any temperature measurement, cut off power supply from the circuit to be measured and make sure that all capacitors are discharged, if present.

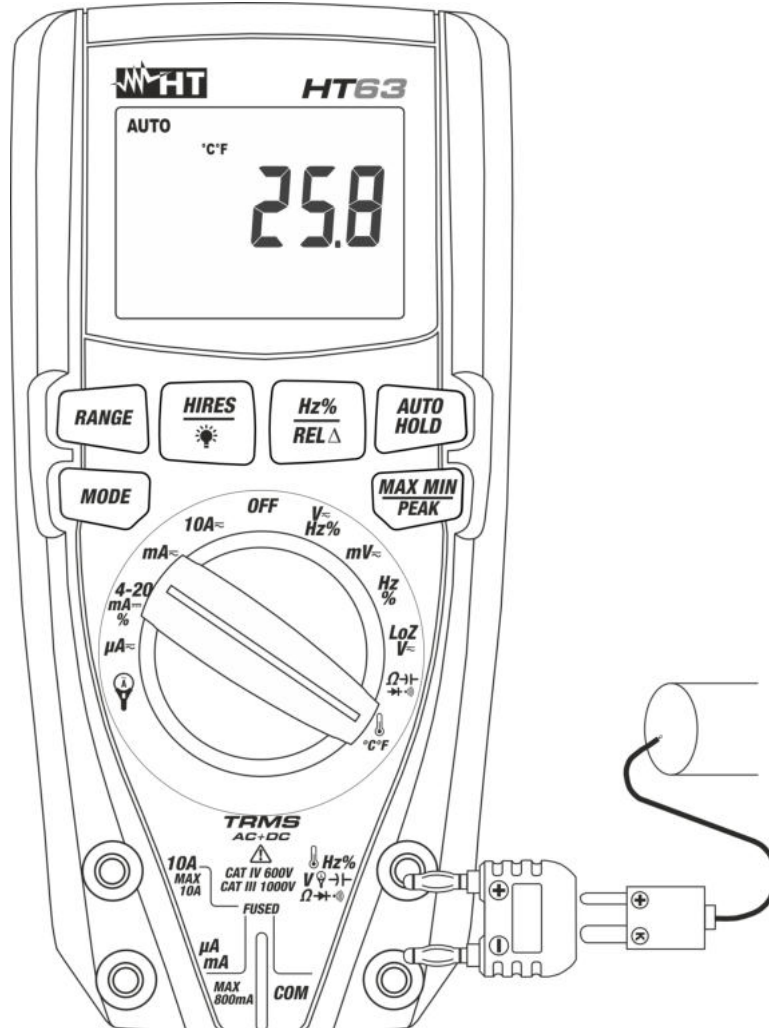

Fig. 9: Use of the instrument for Temperature measurement

1. Select position °C° F
2. Press the **MODE** key until the symbol “°C” or “°F” is displayed.
3. Insert the provided adapter into input terminals Hz% V~ Hz% Ω~ (polarity +) and **COM** (polarity -) (see Fig. 9)
4. Connect the provided K-type wire probe or the optional K-type thermocouple (see §) to the instrument by means of the adapter, respecting the positive and negative polarity on it. The display shows the value of temperature. The bargraph is not active in this function.
5. The message “O.L.” indicates that the value of temperature exceeds the maximum measurable value.
6. To use the HOLD function, see § 4.2.

5.9. DC CURRENT MEASUREMENT AND E 4-20mA% READING

CAUTION



Maximum input DC current is 10A (input **10A**) or 600mA (input **mA μ A**). Do not measure currents exceeding the limits given in this manual. Exceeding voltage limits could result in electrical shocks to the user and damage to the instrument.

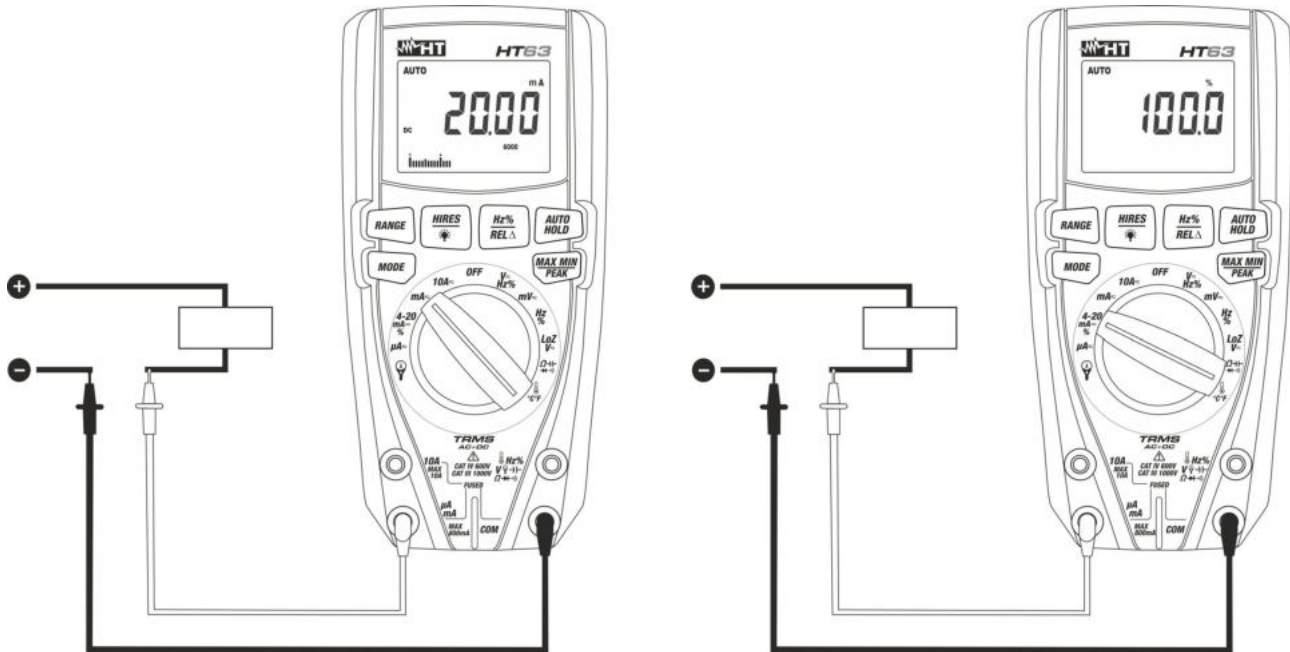

Fig. 10: Use of the instrument for DC current measurement and 4-20mA% reading.

1. Cut off power supply from the circuit to be measured.
2. Select position μA , mA or 10A to measure DC current or the same position **4-20mA%** for 4-20mA% reading.
3. Insert the red cable into input terminal **10A** or into input terminal **mA μ A** and the black cable into input terminal **COM**.
4. Connect the red lead and the black lead in series to the circuit whose current you want to measure, respecting polarity and current direction (see Fig. 10).
5. Supply the circuit to be measured.
6. The value of DC current (see Fig. 10 – left side) appears on the display.
7. The value of reading 4-20mA% (0mA = -25%, 4mA = 0%, 20mA = 100% and 24mA = 125%) (see Fig. 10 – right side) appears on the display. The bargraph is not active in this function
8. If the display shows the message “**O.L**”, the maximum measurable value has been reached.
9. When symbol “-” appears on the instrument's display, it means that current has the opposite direction with respect to the connection in Fig. 10.
10. To use the HOLD, RANGE, MAX MIN, REL Δ and HIRESE functions, see § 4.2

5.10. AC, AC+DC CURRENT MEASUREMENT

CAUTION



Maximum input AC current is 10A (input **10A**) or 600mA (input **mA μ A**). Do not measure currents exceeding the limits given in this manual. Exceeding voltage limits could result in electrical shocks to the user and damage to the instrument.

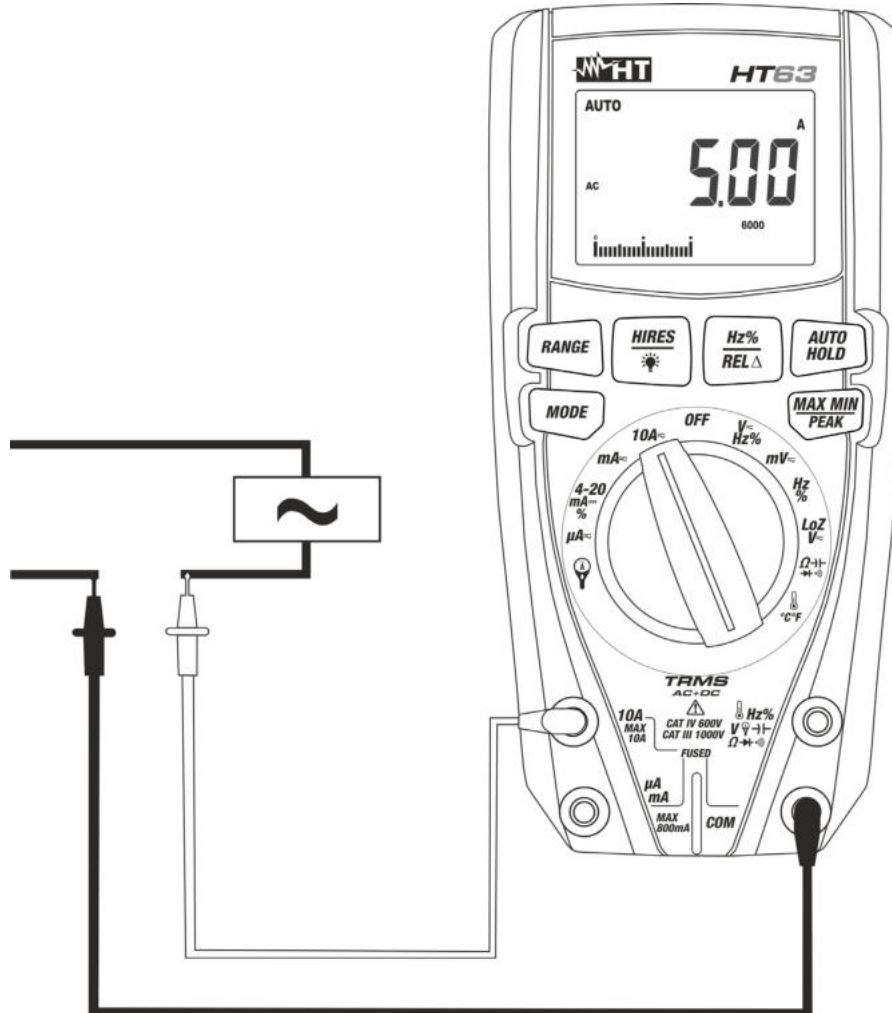

Fig. 11: Use of the instrument for AC current measurement

1. Cut off power supply from the circuit to be measured.
2. Select positions μA , mA or 10A
3. Press the **MODE** key to select "AC" or "AC+DC" measurement.
4. Insert the red cable into input terminal **10A** or into input terminal **mA μ A** and the black cable into input terminal **COM**.
5. Connect the red lead and the black lead in series to the circuit whose current you want to measure (see Fig. 11).
6. Supply the circuit to be measured. The display shows the value of current.
7. If the display shows the message "O.L.", the maximum measurable value has been reached.
8. Press the **Hz%/REL Δ** key to select measurements "Hz" or "%" in order to display the values of frequency and duty cycle of input voltage. The bargraph is not active in these functions.
9. To use the HOLD, RANGE, MAX MIN, PEAK, REL Δ and HIRES functions, see § 4.2

5.11. AC, DC, AC+DC CURRENT MEASUREMENT WITH TRANSDUCER CLAMPS
CAUTION

- Maximum current measurement in this function is 3000A AC or 1000A DC. Do not measure currents exceeding the limits given in this manual
- The instrument performs the measurement by using both flexible transducer clamp (optional accessory F3000U) and other **standard** clamp transducers of HT family. For transducer clamps with Hypertac output connector is necessary the NOCANBA optional adapter in order to perform the connection

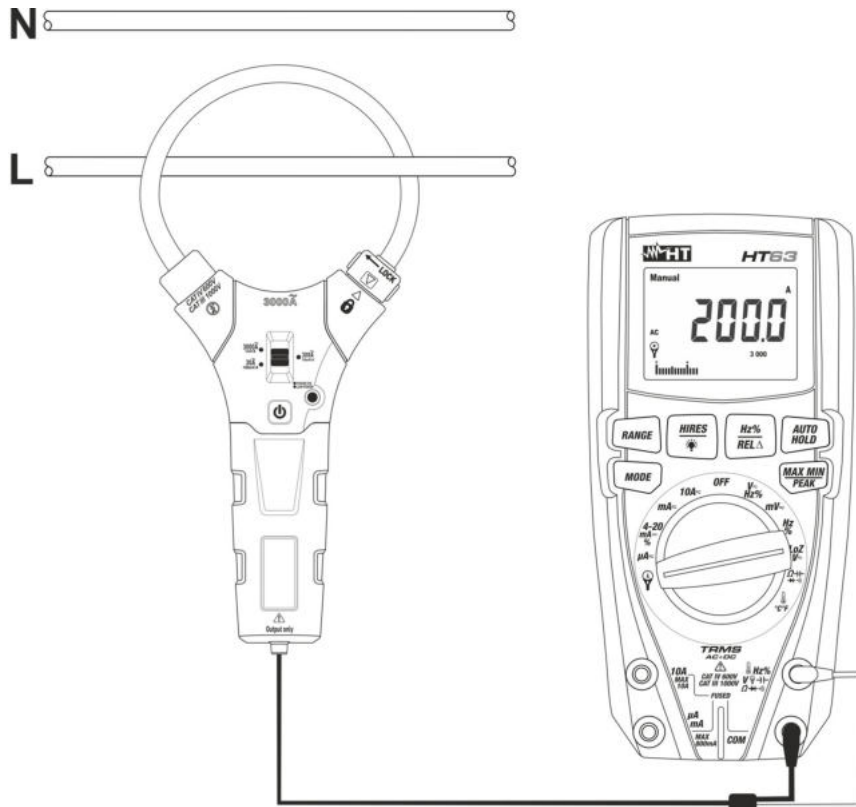

Fig. 12: Use of the instrument for AC/DC current measurement with transducer clamps

1. Select position
2. Press **MODE** key to select “AC”, “DC” or “AC+DC” measurement
3. Press **RANGE** key to select on the instrument the **same range** set on the transducer clamp among the options: **1000mA, 10A, 30A, 40A (only HT4006), 100A, 300A, 400A (only HT4006), 1000A, 3000A**. The selected range appear for 2s on the display
4. Insert the red cable into input terminal and the black cable into input terminal **COM**. For other standard transducers (see § 7.3.2) with Hypertac connector use the NOCANBA optional accessory. For information about the use of transducer clamps refer to relative user manual
5. Insert the cable inside the jaw (see Fig. 32). The value of current appears on the display
6. Press the **HZ%/RELΔ** key to select measurements “Hz” o “%” in order to display the values of frequency and duty cycle of input current. The bargraph is not active in these functions. Press the **MODE** key to go back to current measurement and set again the correct range press **RANGE** key
7. If the display shows the message “O.L”, the maximum measurable value has been reached
8. To use the HOLD, RANGE, MAX MIN, PEAK, RELΔ and HIRES functions, see § 4.2

6. MAINTENANCE

CAUTION







- Only expert and trained technicians should perform maintenance operations. Before carrying out maintenance operations, disconnect all cables from the input terminals.
- Do not use the instrument in environments with high humidity levels or high temperatures. Do not expose to direct sunlight.
- Always switch off the instrument after use. In case the instrument is not to be used for a long time, remove the battery to avoid liquid leaks that could damage the instrument's internal circuits.





6.1. REPLACING THE BATTERIES AND THE INTERNAL FUSES

When the LCD display shows the symbol , it is necessary to replace the battery.

Replacing the battery

1. Position the rotary switch to **OFF** and remove the cables from the input terminals.
2. Turn the fastening screw of the battery compartment cover from position  to position  and remove it.
3. Remove the battery and insert a new battery of the same type (see § 7.1.2), respecting the indicated polarity.
4. Restore the battery compartment cover into place and turn the fastening screw from position  to position .
5. Do not scatter old batteries into the environment. Use the relevant containers for disposal.

Replacement of fuses

1. Position the rotary switch to **OFF** and remove the cables from the input terminals.
2. Turn the fastening screw of the battery compartment cover from position  to position  and remove it.
3. Remove the damaged fuse and insert a new fuse of the same type (see § 7.1.2).
4. Restore the battery compartment cover into place and turn the fastening screw from position  to position .

6.2. CLEANING THE INSTRUMENT

Use a soft and dry cloth to clean the instrument. Never use wet cloths, solvents, water, etc.

6.3. END OF LIFE



WARNING: the symbol on the instrument indicates that the appliance and its accessories must be collected separately and correctly disposed of.

7. TECHNICAL SPECIFICATIONS

7.1. TECHNICAL CHARACTERISTICS

Accuracy calculated as [%reading + (num. digits*resolution)] at 18°C ÷ 28°C <75%RH

DC Voltage

Range (*)	Resolution	Accuracy	Input impedance	Protection against overcharge
600.0mV	0.1mV	$\pm(0.9\%rdg + 5dgt)$	>10M Ω	1000VDC/ACrms
6.000V	0.001V			
60.00V	0.01V			
600.0V	0.1V			
1000V	1V	$\pm(1.2\%rdg + 5dgt)$		

(*) HIRES feature not active. With HIRES feature active, multiply x10 the dgts of the accuracy

AC TRMS Voltage

Range (*)	Resolution	Accuracy (**)		Protection against overcharge
		(50Hz÷1kHz)	(1kHz÷5kHz)	
600.0mV	0.1mV	$\pm(1.0\%rdg + 5dgt)$	$\pm(3.0\%rdg + 5dgt)$	1000VDC/ACrms
6.000V	0.001V			
60.00V	0.01V			
600.0V	0.1V			
1000V	1V		Not specified	

(*) HIRES feature not active. With HIRES feature active, multiply x10 the dgts of the accuracy

(**) Accuracy specified from 5% to 100% of the measuring range and crest factor \leq 3, Input impedance: > 10M Ω

Accuracy PEAK function: $\pm(10\%rdg + 30dgt)$, Response time PEAK function: 1ms

Accuracy function: $\pm(1.5\%rdg + 5dgt)$ ($f \leq 60Hz$), $\pm(3.0\%rdg + 5dgt)$ ($60Hz \leq f \leq 1kHz$), not specified ($f: 1 \div 5kHz$)

For not sinusoidal waveforms the accuracy is: $\pm(4.5\%rdg + 10dgt)$ (50Hz÷1kHz), $\pm(10.0\%rdg + 10dgt)$ (1kHz÷5kHz)

AC+ DC TRMS Voltage

Range (*)	Resolution	Accuracy (50Hz÷1kHz)	Input impedance	Protection against overcharge
600.0mV	0.1mV	$\pm(1.5\%rdg + 10dgt)$	>10M Ω	1000VDC/ACrms
6.000V	0.001V			
60.00V	0.01V			
600.0V	0.1V			
1000V	1V			

(*) HIRES feature not active. With HIRES feature active, multiply x10 the dgts of the accuracy

DC/AC TRMS Voltage with low impedance (LoZ)

Range (*)	Resolution	Accuracy (**)	Input impedance	Protection against overcharge
6.000V	0.001V	$\pm(3.0\%rdg+40dgt)$	approx 3k Ω	600VDC/ACrms
60.00V	0.01V			
600.0V	0.1V			
600V	1V			

(*) HIRES feature not active. With HIRES feature active, multiply x10 the dgts of the accuracy

(**) Accuracy AC+DC: $\pm(3.5\%rdg+40dgt)$

Diode test

Function	Test current	Max voltage with open circuit
	<1.5mA	2.8VDC

4-20mA% reading

Range (*)	Resolution	Accuracy	Correspondence
-25%÷125%	0.1%	$\pm(50digits)$	0mA=-25%, 4mA=0%, 20mA=100%, 24mA=125%

(*)HIRES feature not active

DC Current

Range (*)	Resolution	Accuracy	Protection against overcharge
600.0μA	0.1μA	±(1.5%rdg + 5dgt)	Quick fuse 800mA/1000V
6000μA	1μA		
60.00mA	0.01mA		
600.0mA	0.1mA		
10.00A	0.01A		Quick fuse 10A/1000V

(*) HIRES feature not active. With HIRES feature active, multiply x10 the dgts of the accuracy

AC TRMS Current

Range (*)	Resolution	Accuracy (**)		Protection against overcharge
		(50Hz÷1kHz)	(1kHz÷5kHz)	
600.0μA	0.1μA	±(2.5%rdg + 5dgt)	±(3.5%rdg+5dgt)	Quick fuse 800mA/1000V
6000μA	1μA			
60.00mA	0.01mA			
600.0mA	0.1mA			
10.00A	0.01A			Quick fuse 10A/1000V

(*) HIRES feature not active. With HIRES feature active, multiply x10 the dgts of the accuracy

(**) Accuracy specified from 5% to 100% of the measuring range, Accuracy PEAK function: ±(10%rdg + 30dgt)

For not sinusoidal waveforms the accuracy is: ±(4.5%rdg + 10dgt) (50Hz÷1kHz), ±(10.0%rdg + 10dgt) (1kHz÷5kHz)

Accuracy AC+DC: ±(2.8%rdg+5dgt) (50Hz ÷ 1kHz)

DC Current with transducer clamp

Range (*)	Output ratio	Resolution	Accuracy (**)	Protection against overcharge
1000mA	1000mV/1000mA	1mA	±(1.5%rdg + 6dgt)	1000VDC/ACrms
10A	100mV/1A	0.01A		
30A		0.01A	±(1.5%rdg + 26dgt)	
40A	10mV/1A	0.1A	±(1.5%rdg + 6dgt)	
100A			±(1.5%rdg + 6dgt)	
300A		±(1.5%rdg + 26dgt)		
400A	1mV/1A	1A	±(1.5%rdg + 6dgt)	
1000A			±(1.5%rdg + 6dgt)	
3000A			±(1.5%rdg + 6dgt)	

(*) HIRES feature not active. With HIRES feature active, multiply x10 the dgts of the accuracy

(**) Accuracy referred to only instrument without transducer clamp

AC TRMS Current with transducer clamp

Range (*)	Output ratio	Resolution	Accuracy (**, ***) (50Hz÷1kHz)	Protection against overcharge
1000mA	1000mV/1000mA	1mA	±(2.5%rdg + 10dgt)	1000VDC/ACrms
10A	100mV/1A	0.01A		
30A		0.01A	±(3.5%rdg + 30dgt)	
40A	10mV/1A	0.1A	±(2.5%rdg + 10dgt)	
100A			±(3.5%rdg + 30dgt)	
300A		±(2.5%rdg + 10dgt)		
400A	1mV/1A	1A	±(3.5%rdg + 30dgt)	
1000A			±(2.5%rdg + 10dgt)	
3000A			±(2.5%rdg + 10dgt)	

(*) HIRES feature not active. With HIRES feature active, multiply x10 the dgts of the accuracy

(**) Accuracy referred to only instrument without transducer clamp

(***) Accuracy specified from 5% to 100% of the measuring range; For pulse waveforms the accuracy is: ±(10.0%rdg + 10dgt)

Accuracy PEAK function: ±(10%rdg + 30dgt), AC+DC TRMS current: accuracy (50Hz÷1kHz): ±(3.0%rdg + 10dgt)

For not sinusoidal waveforms the accuracy is: ±(4.5%rdg + 10dgt) (50Hz÷1kHz)

Resistance and Continuity test

Range (*)	Resolution	Accuracy	Buzzer	Protection against overcharge
600.0Ω	0.1Ω	±(2.0%rdg + 9digits)	<35Ω	1000VDC/ACrms
6.000kΩ	0.001kΩ	±(1.2%rdg + 5digits)		
60.00kΩ	0.01kΩ			
600.0kΩ	0.1kΩ			
6.000MΩ	0.001MΩ	±(2.0%rdg + 10digits)		
60.00MΩ	0.01MΩ			

(*) HIRES feature not active. With HIRES feature active, multiply x10 the dgts of the accuracy

Frequency (electronic circuits)

Range (*)	Resolution	Accuracy	Protection against overcharge
40.00Hz ÷ 10kHz	0.01Hz	±(0.5%reading)	1000VDC/ACrms

(*) HIRES feature not active. With HIRES feature active, multiply x10 the dgts of the accuracy

Frequency (electronic circuits)

Range (*)	Resolution	Accuracy	Protection against overcharge
60.00Hz	0.01Hz	±(1.0%rdg + 2digits)	1000VDC/ACrms
600.0Hz	0.1Hz		
6.000kHz	0.001kHz		
60.00kHz	0.01kHz		
600.0kHz	0.1kHz		
6.000MHz	0.001MHz		
10.00MHz	0.01MHz		

(*) HIRES feature not active. With HIRES feature active, multiply x10 the dgts of the accuracy

Sensitivity: >2.0Vrms (@ 20% ÷ 80% duty cycle) and f<100kHz; >5Vrms (@ 20% ÷ 80% duty cycle) and f>100kHz

Duty Cycle

Range (*)	Resolution	Accuracy
0.1% ÷ 99.9%	0.1%	±(1.2%reading + 2digits)

(*) HIRES feature not active. With HIRES feature active, multiply x10 the dgts of the accuracy

Pulse frequency range: 5Hz ÷ 10kHz, Pulse amplitude: ±5V (100μs ÷ 100ms)

Capacitance

Range	Resolution	Accuracy	Protection against overcharge
60.00nF	0.01nF	±(3.5%rdg + 10digits)	1000VDC/ACrms
600.0nF	0.1nF		
6.000μF	0,001μF	±(2.5%rdg + 10digits)	
60.00μF	0.01μF		
600.0μF	0.1μF		
6000μF	1μF	±(3.5%rdg + 10digits)	

Temperature with K-type probe

Range	Resolution	Accuracy (*)	Protection against overcharge
-40.0°C ÷ 600.0°C	0.1°C	±(2.0%rdg + 3°C)	1000VDC/ACrms
600°C ÷ 760°C	1°C		
-58.0°F ÷ 600.0°F	0.1°F	±(2.0%rdg + 5.5°F)	
600°F ÷ 1400°F	1°F		

(*) Instrument accuracy with no probe

7.1.1. Reference standards

Safety / EMC:

IEC/EN61010-1 / IEC/EN 61326-1

Insulation:

double insulation

Pollution level:

2

Overvoltage category:

CAT IV 600V, CAT III 1000V

7.1.2. General characteristics

Mechanical characteristics

Size (L x W x H):	175 x 85 x 55mm (7 x 3 x 2in)
Weight (batteries included):	360g (13 ounces)
Mechanical protection:	IP40

Power supply

Battery type:	4x1.5V batteries type AAA IEC LR03
Low battery indication:	symbol  on the display
Battery life:	ca.18h (backlight ON), ca 60h (backlight OFF)
Auto Power Off:	after 15 minutes' idling (can be disabled)
Fuses:	F10A/1000V, 10 x 38mm (input 10A) F800mA/1000V, 6 x 32mm (input mAμA)

Display

Conversion:	TRMS
Characteristics:	3½ LCD, 6000 dots, decimal sign, point 4½ LCD, 60000 dots, decimal sign, point backlight and bargraph
Sampling frequency:	3 times/s

7.2. ENVIRONMENT

7.2.1. Environmental conditions for use

Reference temperature:	18°C ÷ 28°C (64°F ÷ 82°F)
Operating temperature:	5°C ÷ 40°C (41°F ÷ 104°F)
Allowable relative humidity:	<80%RH
Storage temperature:	-20°C ÷ 60°C (-4°F ÷ 140°F)
Storage humidity:	<80%RH
Max operating altitude:	2000m (6562ft)

This instrument satisfies the requirements of Low Voltage Directive 2014/35/EU (LVD) and of EMC Directive 2014/30/EU
This instrument satisfies the requirements of European Directive 2011/65/EU (RoHS) and 2012/19/EU (WEEE)

7.3. ACCESSORIES

7.3.1. Accessories provided

- Pair of test leads with 2/4mm tips
- Adapter + K-type wire probe
- Batteries
- Carrying bag
- User manual

7.3.2. Optional accessories

• K-type probe for air and gas temperature	Code TK107
• K-type probe for semisolid substance temperature	Code TK108
• K-type probe for liquid substance temperature	Code TK109
• K-type probe for surface temperature	Code TK110
• K-type probe for surface temperature with 90° tip	Code TK111
• Flexible transducer clamp AC 30/300/3000A	Cod. F3000U
• Standard transducer clamp AC 1-100-1000A/1V	Cod. HT96U
• Standard transducer clamp AC 10-100-1000A/1V	Cod. HT97U
• Standard transducer clamp DC 1000A/1V	Cod. HT98U
• Standard transducer clamp AC/DC 40/400	Cod. HT4006
• Adapter for connection of standard transducer clamp	Cod. NOCANBA

8. ASSISTANCE

8.1. WARRANTY CONDITIONS

This instrument is warranted against any material or manufacturing defect, in compliance with the general sales conditions. During the warranty period, defective parts may be replaced. However, the manufacturer reserves the right to repair or replace the product. Should the instrument be returned to the After-sales Service or to a Dealer, transport will be at the Customer's charge. However, shipment will be agreed in advance. A report will always be enclosed to a shipment, stating the reasons for the product's return. Only use original packaging for shipment. Any damage due to the use of non-original packaging material will be charged to the Customer. The manufacturer declines any responsibility for injury to people or damage to property.

The warranty shall not apply in the following cases:

- Repair and/or replacement of accessories and battery (not covered by warranty).
- Repairs that may become necessary as a consequence of an incorrect use of the instrument or due to its use together with non-compatible appliances.
- Repairs that may become necessary as a consequence of improper packaging.
- Repairs which may become necessary as a consequence of interventions performed by unauthorized personnel.
- Modifications to the instrument performed without the manufacturer's explicit authorization.
- Use not provided for in the instrument's specifications or in the instruction manual.

The content of this manual cannot be reproduced in any form without the manufacturer's authorization.

Our products are patented and our trademarks are registered. The manufacturer reserves the right to make changes in the specifications and prices if this is due to improvements in technology.

8.2. ASSISTANCE

If the instrument does not operate properly, before contacting the After-sales Service, please check the conditions of battery and cables and replace them, if necessary. Should the instrument still operate improperly, check that the product is operated according to the instructions given in this manual. Should the instrument be returned to the After-sales Service or to a Dealer, transport will be at the Customer's charge. However, shipment will be agreed in advance. A report will always be enclosed to a shipment, stating the reasons for the product's return. Only use original packaging for shipment; any damage due to the use of non-original packaging material will be charged to the Customer.