

**ENGLISH**

# **User manual**



**Table of contents:**

|  |    |
|--|----|
| 1. PRECAUTIONS AND SAFETY MEASURES .....   | 2  |
| 1.1. Preliminary instructions .....  | 2  |
| 1.2. During use .....  | 3  |
| 1.3. After use .....   | 3  |
| 1.4. Definition of Measurement (Overvoltage) category .....  | 3  |
| 2. GENERAL DESCRIPTION .....   | 4  |
| 2.1. Measuring average values and TRMS values .....  | 4  |
| 2.2. Definition of true root mean square value and crest factor .....                              | 4  |
| 3. PREPARATION FOR USE .....   | 5  |
| 3.1. Initial checks .....  | 5  |
| 3.2. Instrument power supply .....   | 5  |
| 3.3. Storage .....   | 5  |
| 4. NOMENCLATURE .....  | 6  |
| 4.1. Description of the instrument .....   | 6  |
| 4.1.1. Hand protection .....   | 6  |
| 4.2. Description of the symbols shown on the display .....   | 7  |
| 4.3. Description of function keys .....  | 7  |
| 4.3.1. HOLD key .....  | 7  |
| 4.3.2. MIN/MAX key .....   | 7  |
| 4.3.3. ZERO key .....  | 7  |
| 4.3.4. Key  ..... | 7  |
| 4.3.5. Auto Power OFF function .....   | 7  |
| 5. OPERATING INSTRUCTIONS .....  | 8  |
| 5.1. DC Voltage measurement .....  | 8  |
| 5.2. AC Voltage measurement .....  | 9  |
| 5.3. Resistance measurement .....  | 10 |
| 5.4. Continuity test .....   | 11 |
| 5.5. DC Current measurement .....  | 12 |
| 5.6. AC Current measurement .....  | 13 |
| 5.7. AC/DC leakage current measurement .....   | 14 |
| 6. MAINTENANCE .....   | 15 |
| 6.1. General information .....   | 15 |
| 6.2. Replacing the batteries .....   | 15 |
| 6.3. Cleaning the instrument .....   | 15 |
| 6.4. End of life .....   | 15 |
| 7. TECHNICAL SPECIFICATIONS .....  | 16 |
| 7.1. Technical characteristics .....   | 16 |
| 7.1.1. Electrical characteristics .....  | 16 |
| 7.1.2. Reference standards .....   | 16 |
| 7.1.3. General characteristics .....   | 17 |
| 7.2. Environment .....   | 17 |
| 7.2.1. Environmental conditions for use .....  | 17 |
| 7.3. Accessories .....   | 17 |
| 7.3.1. Accessories provided .....  | 17 |
| 8. ASSISTANCE .....  | 18 |
| 8.1. Warranty conditions .....   | 18 |
| 8.2. Assistance .....  | 18 |

## 1. PRECAUTIONS AND SAFETY MEASURES

The instrument has been designed in compliance with directive IEC/EN61010-1 relevant to electronic measuring instruments. For your safety and in order to prevent damaging the instrument, please carefully follow the procedures described in this manual and read all notes preceded by symbol  with the utmost attention.



### CAUTION

Failure to comply with the caution notes and/or instructions may damage the instrument and/or its components and be a source of danger for the operator.

Before and after carrying out the measurements, carefully observe the following instructions:

- Do not carry out any current measurement in humid environments.
- Do not carry out any measurements in case gas, explosive materials or flammables are present, or in dusty environments.
- Avoid any contact with the circuit being measured if no measurements are being carried out.
- Avoid contact with exposed metal parts, with unused measuring probes, etc.
- Do not carry out any measurement in case you find anomalies in the instrument such as deformation, substance leaks, absence of display on the screen, etc.
- Pay special attention when measuring voltages higher than 20V, since a risk of electrical shock exists

In this manual, and on the instrument, the following symbols are used:



Warning: observe the instructions given in this manual; improper use could damage the instrument or its components.



Double-insulated meter.



AC current or voltage



DC current or voltage



Connection to earth



The instrument can operate on naked live conductors

### 1.1. PRELIMINARY INSTRUCTIONS

- This instrument has been designed for use in environments of pollution degree 2.
- It can be used for **CURRENT** and **VOLTAGE** measurements on installations with measurement category CAT IV 300V. For a definition of categories, see § 1.4.
- We recommend following the normal safety rules devised to protect the user against dangerous currents and the instrument against incorrect use.
- Only the leads supplied with the instrument guarantee compliance with the safety standards. They must be in good conditions and be replaced with identical models, when necessary.
- Do not test circuits exceeding the specified current and voltage limits.
- Check that the battery is correctly inserted.
- Before connecting the test leads to the circuit to be tested, make sure that the switch is correctly set.
- Make sure that the LCD display and the rotary switch indicate the same function.

## 1.2. DURING USE

Please carefully read the following recommendations and instructions:



### CAUTION

Failure to comply with the caution notes and/or instructions may damage the instrument and/or its components or be a source of danger for the operator.

- Before switching on the clamp, remove the conductor from the clamp jaw.
- When the instrument is connected to the circuit being tested, do not touch any unused terminal.
- During current measurement, any other current near the clamp may affect measurement precision.
- When measuring current, always put the conductor as near as possible to the middle of the clamp jaw, as described in § 4.1.1, in order to obtain the most accurate reading.
- While measuring, if the value or the sign of the quantity being measured remain unchanged, check if the HOLD function is enabled.

## 1.3. AFTER USE

- When measurement is complete, switch off the clamp.
- If you expect not to use the instrument for a long period, remove the battery.

## 1.4. DEFINITION OF MEASUREMENT (OVERVOLTAGE) CATEGORY

Standard "IEC/EN61010-1: Safety requirements for electrical equipment for measurement, control and laboratory use, Part 1: General requirements", defines what measurement category, commonly called overvoltage category, is. § 6.7.4: Measured circuits, circuits are divided into the following measurement categories:

(OMISSIS)

- **Measurement category IV** is for measurements performed at the source of the low-voltage installation.  
*Examples are electricity meters and measurements on primary overcurrent protection devices and ripple control units.*
- **Measurement category III** is for measurements performed on installations inside buildings.  
*Examples are measurements on distribution boards, circuit breakers, wiring, including cables, bus-bars, junction boxes, switches, socket-outlets in the fixed installation, and equipment for industrial use and some other equipment, for example, stationary motors with permanent connection to fixed installation.*
- **Measurement category II** is for measurements performed on circuits directly connected to the low-voltage installation.  
*Examples are measurements on household appliances, portable tools and similar equipment.*
- **Measurement category I** is for measurements performed on circuits not directly connected to MAINS.  
*Examples are measurements on circuits not derived from MAINS, and specially protected (internal) MAINS-derived circuits. In the latter case, transient stresses are variable; for that reason, the standard requires that the transient withstand capability of the equipment is made known to the user.*

## 2. GENERAL DESCRIPTION

The instrument carries out the following measurements:

- DC and AC TRMS voltage up to 300V
- DC current from 0.1mA up to 10A
- AC TRMS current from 0.1mA up to 20A
- AC and DC leakage current
- Resistance and continuity test with buzzer

Each of these functions may be selected through a 6-position rotary switch, including the OFF position and a key for enabling the HOLD function. The instrument also has a “MAX/MIN”, “ZERO” and “” key. For their use, please refer to § 4.2. The selected quantity appears on the LCD display with the indication of the measuring unit and of the enabled functions.

### 2.1. MEASURING AVERAGE VALUES AND TRMS VALUES

Measuring instruments of alternating quantities are divided into two big families:

- AVERAGE-VALUE meters: instruments measuring the value of the sole wave at fundamental frequency (50 or 60 Hz).
- TRMS (True Root Mean Square) VALUE meters: instruments measuring the TRMS value of the quantity being tested.

With a perfectly sinusoidal wave, the two families of instruments provide identical results. With distorted waves, instead, the readings shall differ. Average-value meters provide the RMS value of the sole fundamental wave; TRSM meters, instead, provide the RMS value of the whole wave, including harmonics (within the instruments bandwidth). Therefore, by measuring the same quantity with instruments from both families, the values obtained are identical only if the wave is perfectly sinusoidal. In case it is distorted, TRMS meters shall provide higher values than the values read by average-value meters.

### 2.2. DEFINITION OF TRUE ROOT MEAN SQUARE VALUE AND CREST FACTOR

The root mean square value of current is defined as follows: *“In a time equal to a period, an alternating current with a root mean square value of 1A intensity, circulating on a resistor, dissipates the same energy that, during the same time, would be dissipated by a direct current with an intensity of 1A”*. This definition results in the numeric expression:

$$G = \sqrt{\frac{1}{T} \int_{t_0}^{t_0+T} g^2(t) dt}$$

The root mean square value is indicated with the acronym RMS.

The Crest Factor is defined as the relationship between the Peak Value of a signal and its

RMS value:  $CF (G) = \frac{G_p}{G_{RMS}}$  This value changes with the signal waveform, for a purely

sinusoidal wave it is  $\sqrt{2} = 1.41$ . In case of distortion, the Crest Factor takes higher values as wave distortion increases.

### **3. PREPARATION FOR USE**

#### **3.1. INITIAL CHECKS**

Before shipping, the instrument has been checked from an electric as well as mechanical point of view. All possible precautions have been taken so that the instrument is delivered undamaged.

However, we recommend generally checking the instrument in order to detect possible damage suffered during transport. In case anomalies are found, immediately contact the forwarding agent. We also recommend checking that the packaging contains all components indicated in § 7.3.1. In case of discrepancy, please contact the Dealer.

In case the instrument should be returned, please follow the instructions given in § 8.

#### **3.2. INSTRUMENT POWER SUPPLY**

The instrument is supplied with 2x1.5V alkaline batteries type AAA IEC LR03, included in the package. When batteries are almost flat, the symbol  appears on the display. Replace the battery by following the instructions given in § 6.2.

The instrument is also equipped with an Auto Power OFF function which automatically switches off the instrument approx. 30 minutes after the last operation was carried out.

#### **3.3. STORAGE**

In order to guarantee precise measurement, after a long storage time under extreme environmental conditions, wait for the instrument to come back to normal operating conditions (see § 7.2.1).

## 4. NOMENCLATURE

### 4.1. DESCRIPTION OF THE INSTRUMENT

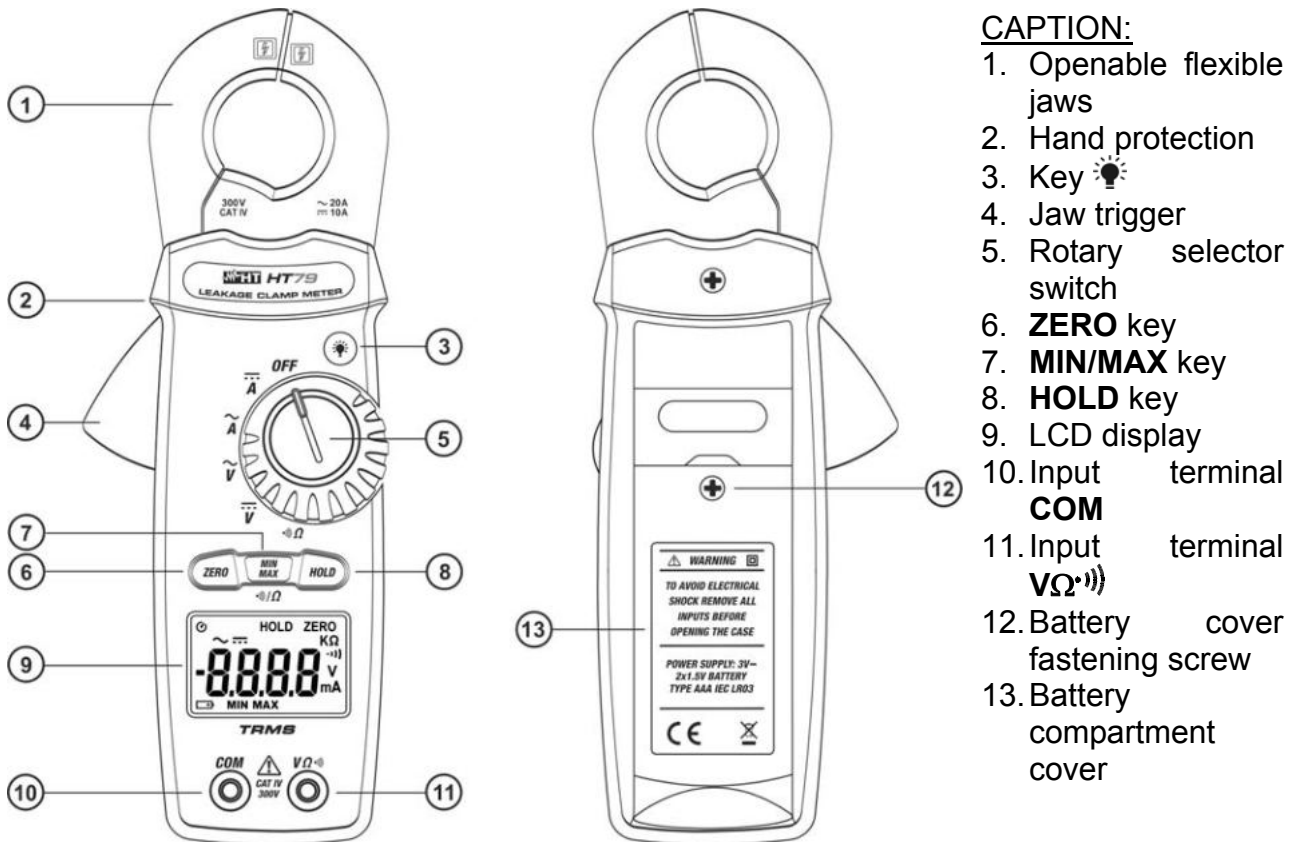

**CAPTION:**

1. Openable flexible jaws
2. Hand protection
3. Key
4. Jaw trigger
5. Rotary selector switch
6. **ZERO** key
7. **MIN/MAX** key
8. **HOLD** key
9. LCD display
10. Input terminal **COM**
11. Input terminal **VΩ**
12. Battery cover fastening screw
13. Battery compartment cover

Fig. 1: Description of the instrument

#### 4.1.1. Hand protection

In order to meet the meter's accuracy specifications, always put the conductor as close as possible to the middle of the jaws (see Fig. 2).

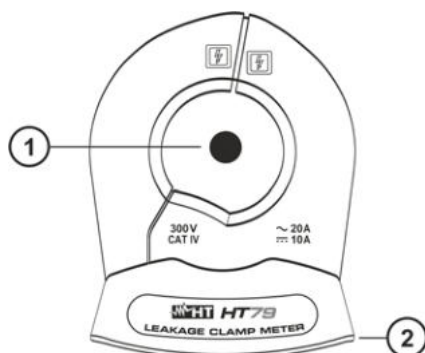

Fig. 2: Hand protection

**CAPTION:**

1. Conductor
2. Hand protection

Always keep your hands under the hand protection. This protection is always located in a suitable position to guarantee a correct safety distance from possible exposed live parts (see Fig. 2)

## 4.2. DESCRIPTION OF THE SYMBOLS SHOWN ON THE DISPLAY

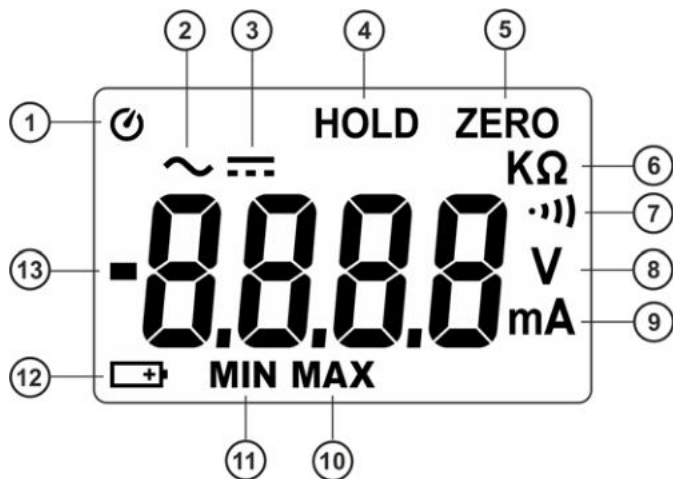

### CAPTION:

1. Auto Power OFF symbol
2. AC quantities symbol
3. DC quantities symbol
4. Active HOLD function
5. Active ZERO function
6. Resistance measuring unit
7. Active continuity test
8. Voltage measuring unit
9. Current measuring unit
10. Active MAX function
11. Active MIN function
12. Low battery symbol
13. Polarity indication

Fig. 3: Display description

## 4.3. DESCRIPTION OF FUNCTION KEYS

### 4.3.1. HOLD key

Shortly pressing the **HOLD** while measuring current allows holding the current value shown on the display. The symbol “HOLD” is shown on the display. Shortly pressing the **HOLD** key again allows quitting the function.

### 4.3.2. MIN/MAX key

Pressing the **MIN/MAX** key once activates the detection of maximum and minimum values of the quantity being tested. Both values are constantly saved and displayed cyclically every time the same key is pressed again. The display shows the symbol associated with the selected function: “MAX” for maximum value and “MIN” for minimum value. This function is not active for resistance measurement and continuity test. Press and hold the **MIN/MAX** key or turn the rotary switch to quit the function. With the rotary switch in position  $\Omega$ ), press the **MIN/MAX** key to select resistance measurement or continuity test.

### 4.3.3. ZERO key

Pressing the **ZERO** key once allows zeroing the displayed value and carrying out a relative measurement of the quantity being tested. When pressing the **ZERO** key, the value of the quantity is saved as offset for the following measurements. The message “ZERO” appears on the display. The instrument shows the relative value obtained as current value – offset. This function is not active for resistance measurements and continuity test and with enabled MIN/MAX function. Press the **ZERO** key again or turn the rotary switch to quit the function.

### 4.3.4. Key

Press the key to activate/deactivate display backlight. This function automatically deactivates after approximately 30 seconds after being activated, in order not to discharge the batteries.

### 4.3.5. Auto Power OFF function

In order to preserve internal batteries, the instrument switches off automatically approximately 30 minutes after it was last used. The symbol indicates that the Auto Power OFF function is activated. To disable the function, proceed as follows:

- Switch off the instrument (**OFF**)
- Press and hold the **HOLD** key and switch on the instrument by turning the rotary switch. The symbol disappears from the display
- Switch off and then on again the instrument to enable the function.

## 5. OPERATING INSTRUCTIONS

### 5.1. DC VOLTAGE MEASUREMENT



#### CAUTION

The maximum input DC voltage is 300V. Do not measure voltages exceeding the limits given in this manual. Exceeding these limits could result in electrical shocks to the user and damage to the instrument.

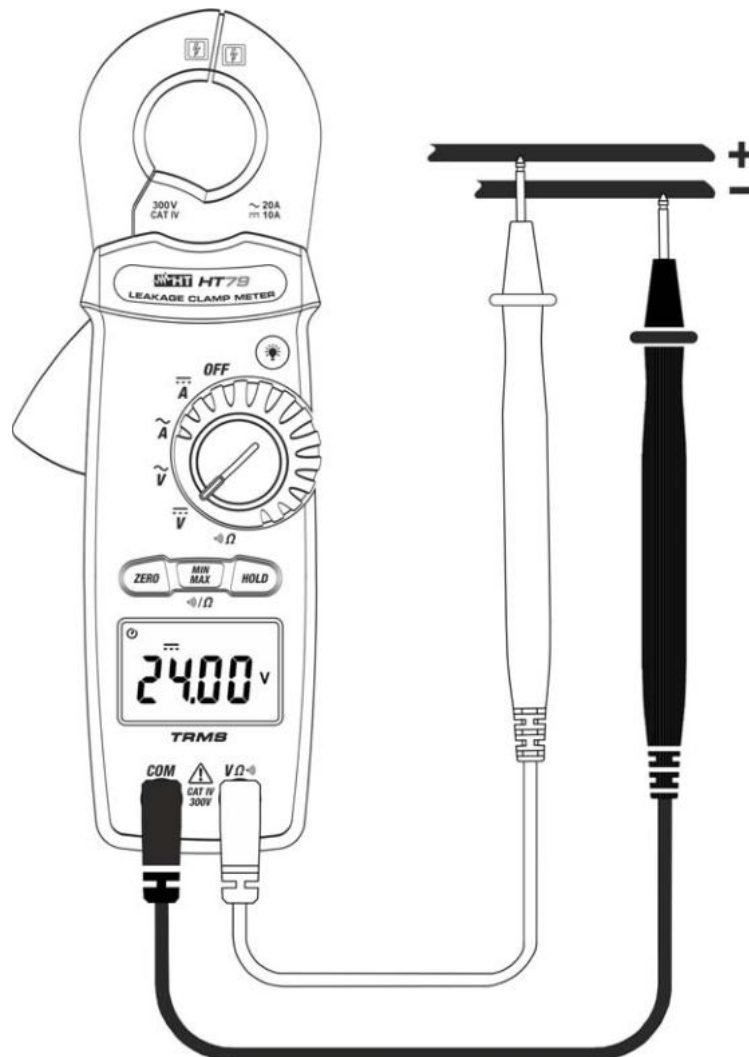

Fig. 4: Use of the instrument for DC voltage measurement

1. Select the position.  $\bar{V}$
2. Insert the red cable into input terminal  $V\Omega$  and the black cable into input terminal **COM**.
3. Position the test leads in the desired spots of the circuit to be measured (see Fig. 4). The display shows the value of voltage.
4. Symbol "OL." appearing on the display indicates the overload condition of the instrument.
5. To use the HOLD, MIN/MAX and ZERO functions, please refer to § 4.3.

## 5.2. AC VOLTAGE MEASUREMENT



### CAUTION

The maximum input AC voltage is 300Vrms. Do not measure voltages exceeding the limits given in this manual. Exceeding these limits could result in electrical shocks to the user and damage to the instrument.

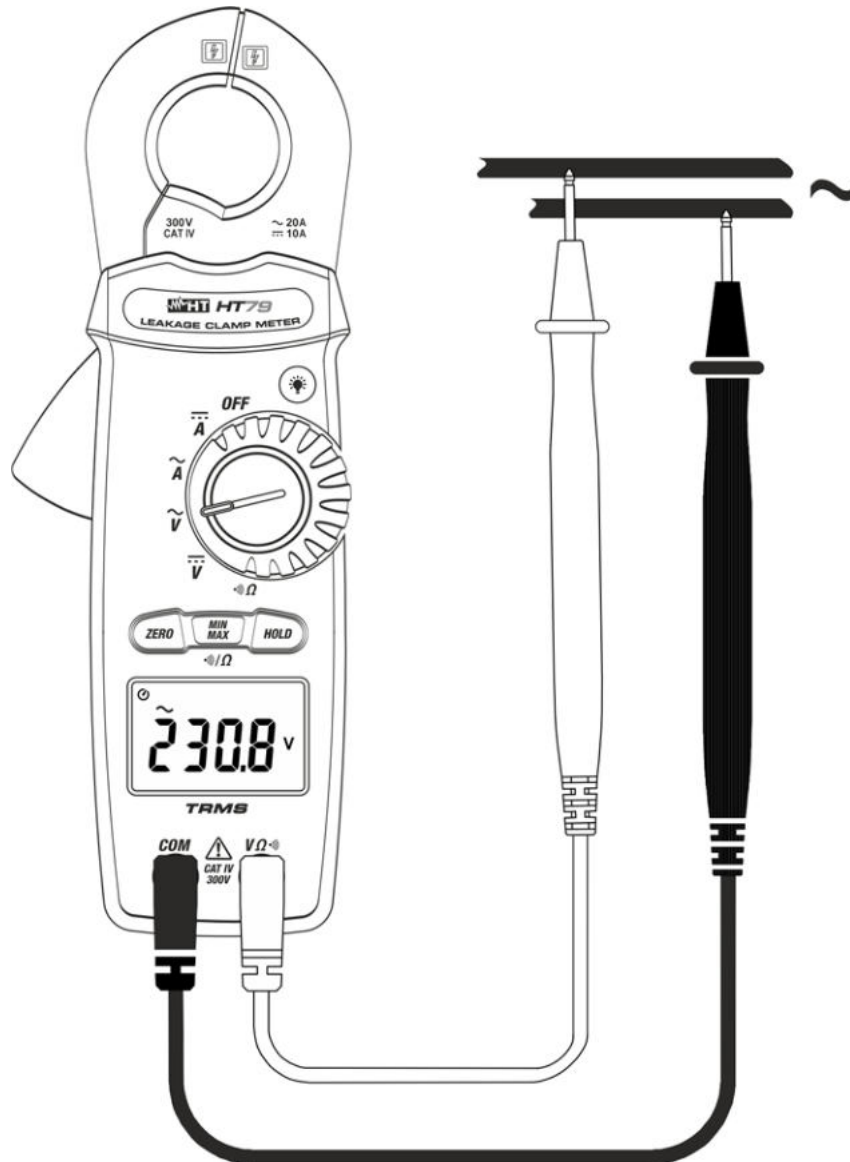

Fig. 5: Use of the instrument for AC voltage measurement

1. Select the position.
2. Insert the red cable into input terminal **VΩ** and the black cable into input terminal **COM**.
3. Position the test leads in the desired spots of the circuit to be measured (see Fig. 5). The display shows the value of voltage.
4. Symbol "**OL.**" appearing on the display indicates the overload condition of the instrument.
5. To use the HOLD, MIN/MAX and ZERO functions, please refer to § 4.3.

### 5.3. RESISTANCE MEASUREMENT



#### CAUTION

Before attempting any resistance measurement, remove power from the circuit under test and discharge all capacitors, if present.

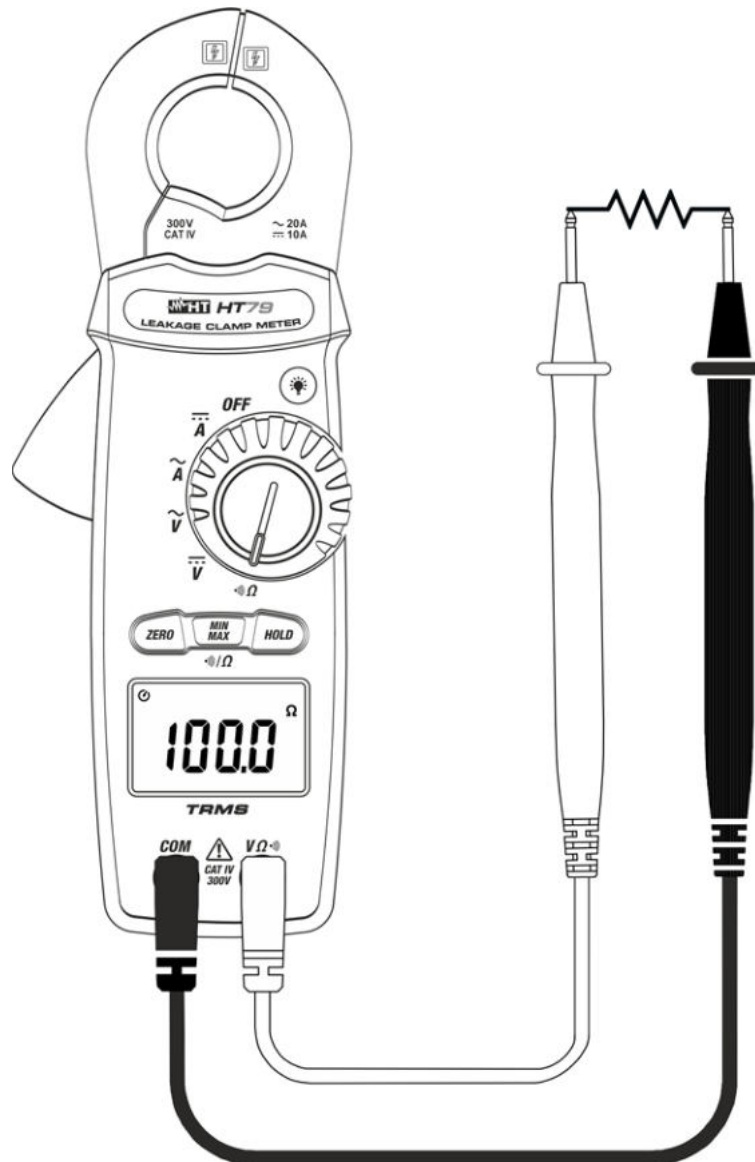

Fig. 6: Use of the instrument for Resistance measurement

1. Select the position.  $\Omega$
2. Insert the red cable into input terminal  $V\Omega$  and the black cable into input terminal **COM**.
3. Position the test leads in the desired spots of the circuit to be measured (see Fig. 6). The display shows the value of resistance.
4. Symbol "OL." appearing on the display indicates the overload condition of the instrument.
5. To use the HOLD function, please refer to § 4.3.1.

## 5.4. CONTINUITY TEST



### CAUTION

Before attempting any resistance measurement, remove power from the circuit under test and discharge all capacitors, if present.

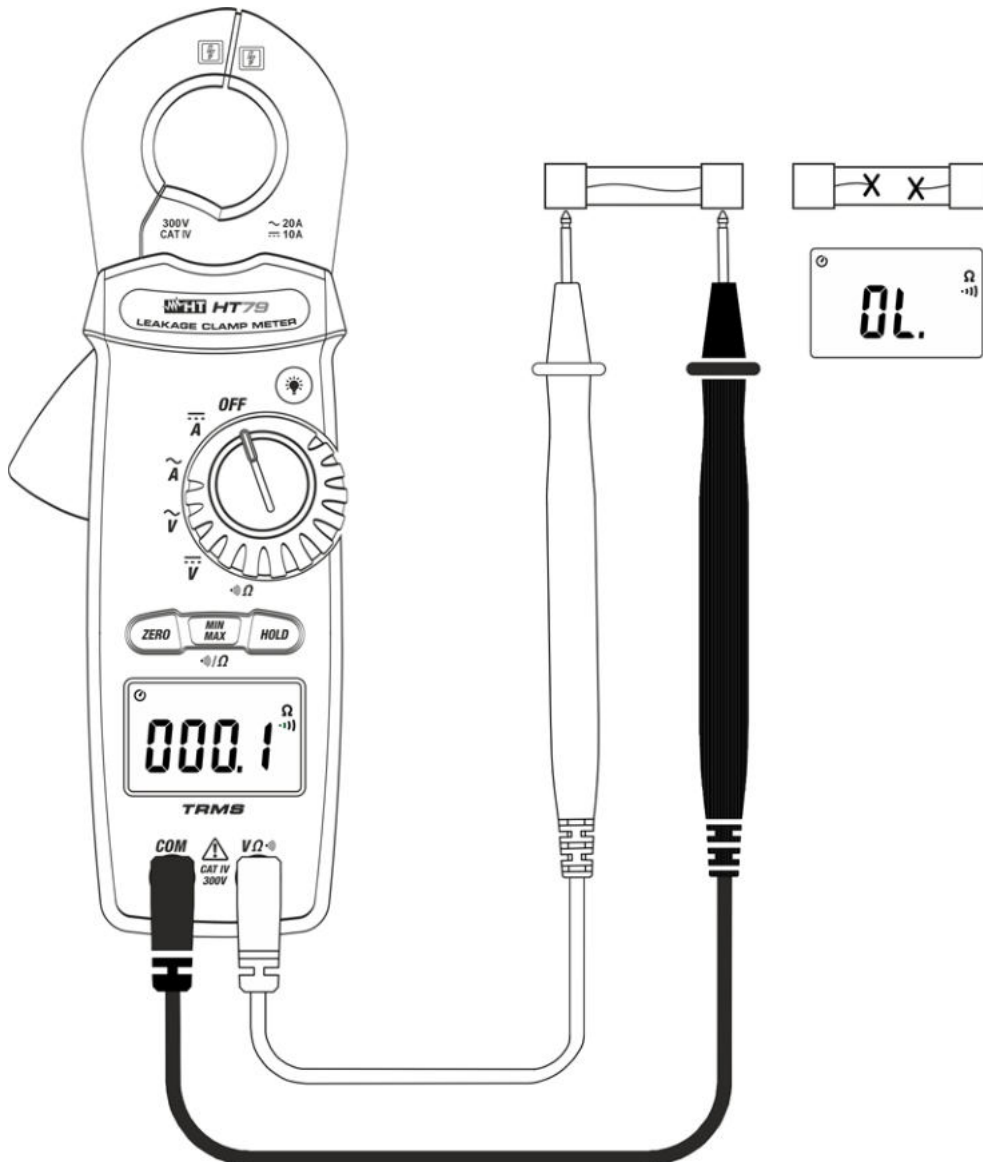

Fig. 7: Use of the instrument for Continuity test

1. Select the position.  $\Omega$
2. Press the **MIN/MAX** key until the symbol “ $\Omega$ ” is displayed.
3. Insert the red cable into input terminal **V $\Omega$**  and the black cable into input terminal **COM** and carry out the continuity test on the object to be tested (see Fig. 7). A buzzer sounds when the measured value of resistance is lower than 100. $\Omega$
4. Symbol “**OL.**” appearing on the display indicates an open circuit condition.

## 5.5. DC CURRENT MEASUREMENT



### CAUTION

Before attempting any measurement disconnect all the test leads from the circuit under test and from the meter's input terminals.

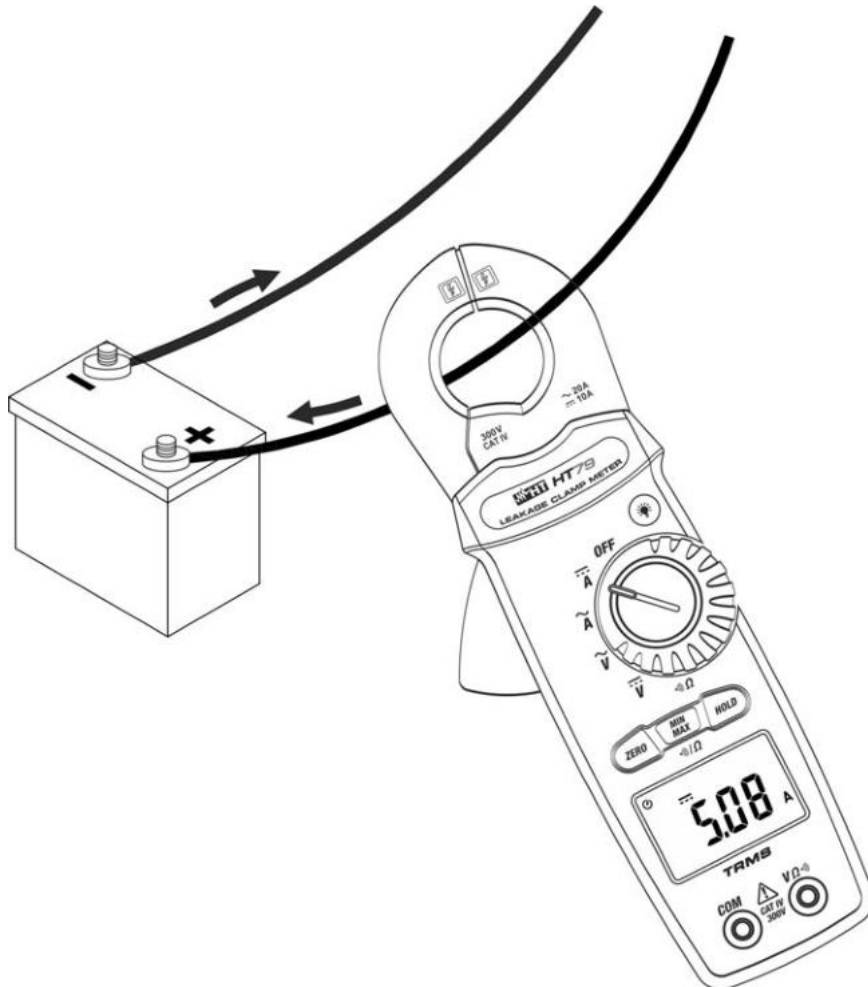

Fig. 8: Use of the instrument for DC current measurement

1. Select the position.
2. Press the **ZERO** key to zero residual magnetization current.
3. Insert the cable in the middle of the clamp jaws (see Fig. 8), in order to obtain accurate measures (see Fig. 2). The display shows the value of DC current.
4. The symbol "-" appearing on the display indicates that the instrument is connected in the opposite direction with respect to the current direction indicated by the arrow located on the side of the jaws.
5. Symbol "**OL.**" appearing on the display indicates the overload condition of the instrument.
6. To use the HOLD, MIN/MAX and ZERO functions, please refer to § 4.3.

## 5.6. AC CURRENT MEASUREMENT



### CAUTION

Before attempting any measurement disconnect all the test leads from the circuit under test and from the meter's input terminals.

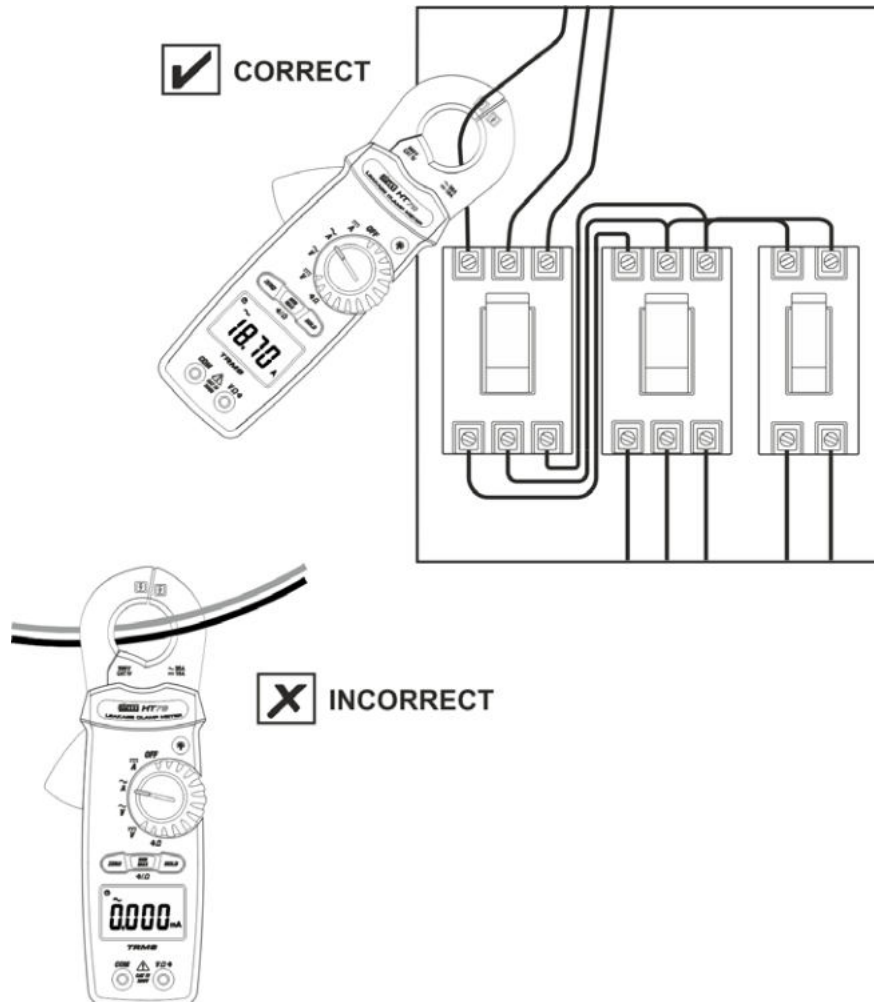

Fig. 9: Use of the instrument for AC current measurement

1. Select the position.
2. Insert the cable in the middle of the clamp jaws (see Fig. 9), in order to obtain accurate measures (see Fig. 2). The display shows the value of AC current.
3. Symbol "OL." appearing on the display indicates the overload condition of the instrument.
4. To use the HOLD, MIN/MAX and ZERO functions, please refer to § 4.3.

## 5.7. AC/DC LEAKAGE CURRENT MEASUREMENT



### CAUTION

Insert the cable(s) in the middle of the clamp jaws, in order to obtain accurate measures (see § 4.1.1).

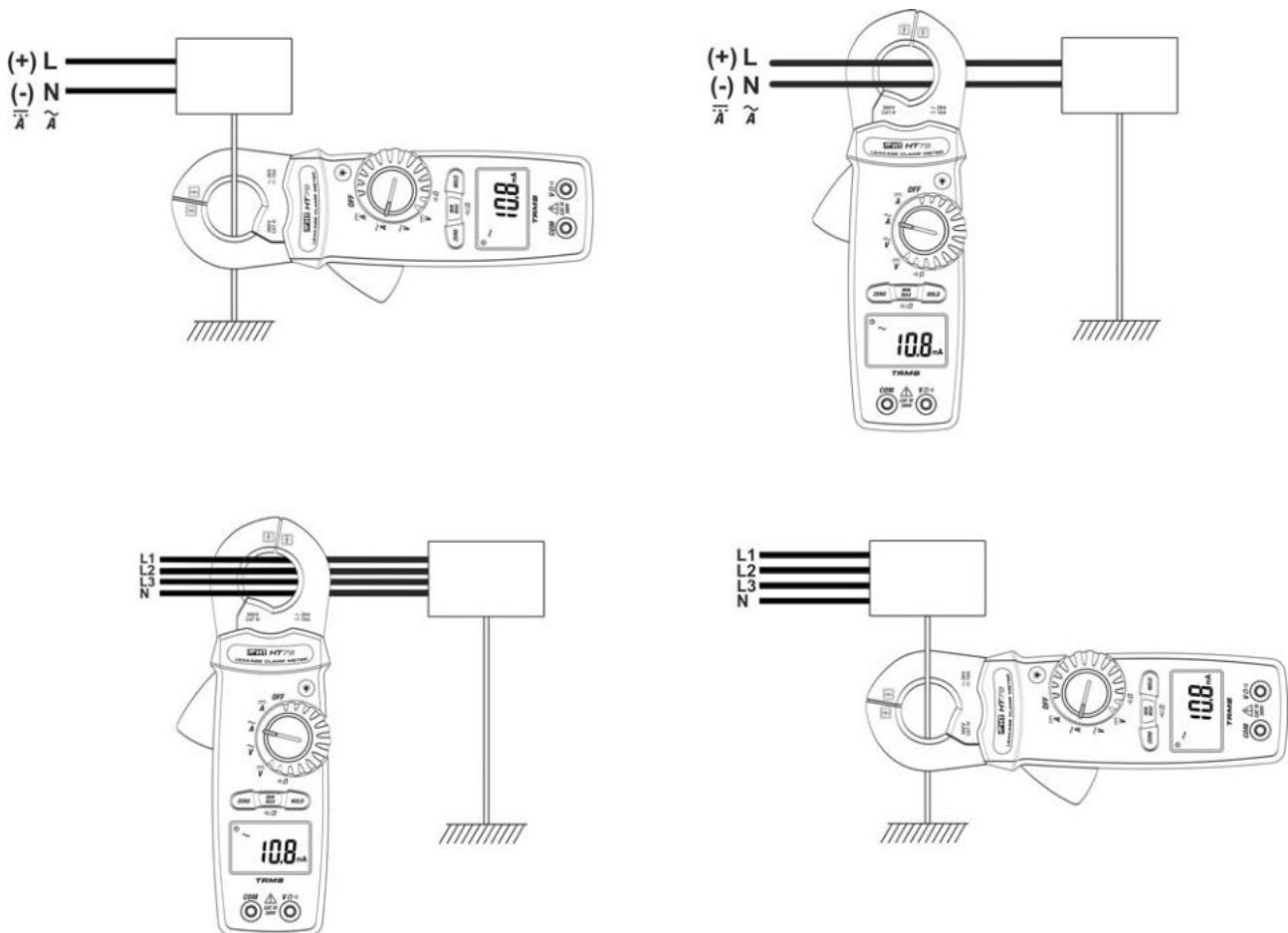

Fig. 10: Use of the instrument for AC or DC leakage current measurement

### Measuring with direct method on earth leads

1. Select position (AC current) or (DC current)
2. To measure DC current, press the **ZERO** key to zero residual magnetization current.
3. Open the clamp jaws and connect the instrument as shown in Fig. 10 for DC systems or single-phase/three-phase 4-wire AC systems. The display shows the value of leakage current.
4. To use the HOLD, MIN/MAX and ZERO functions, please refer to § 4.3.

### Measuring with indirect method

1. Select position (AC current) or (DC current)
2. To measure DC current, press the **ZERO** key to zero residual magnetization current.
3. Open the clamp jaws and connect the instrument as shown in Fig. 10 for DC systems or single-phase/three-phase 4-wire AC systems. The display shows the value of leakage current.
4. To use the HOLD, MIN/MAX and ZERO functions, please refer to § 4.3.

## 6. MAINTENANCE

### 6.1. GENERAL INFORMATION

1. While using and storing the instrument, carefully observe the recommendations listed in this manual in order to prevent possible damage or danger during use.
2. Do not use the instrument in environments with high humidity levels or high temperatures. Do not expose to direct sunlight.
3. Always switch off the instrument after use. In case the instrument is not to be used for a long time, remove the battery to avoid liquid leaks that could damage the instrument's internal circuits.

### 6.2. REPLACING THE BATTERIES

When the LCD display shows symbol , batteries must be replaced.



#### CAUTION

Only expert technicians should perform this operation. Before carrying out this operation, make sure you have removed the cable being tested from inside the clamp jaw.

1. Switch off the instrument by turning the rotary switch to the **OFF** position.
2. Remove the cable being tested from the clamp jaw.
3. Loosen the fastening screw of the battery compartment cover (see Fig. 1 – part 12) and remove it.
4. Remove all batteries and replace them with new batteries of the same type (see § 7.1.3), respecting the indicated polarity.
5. Restore the battery compartment cover into place and fasten it by means of the relevant screw.
6. Do not scatter old batteries into the environment. Use the relevant containers for disposal.

### 6.3. CLEANING THE INSTRUMENT

Use a soft and dry cloth to clean the instrument. Never use wet cloths, solvents, water, etc.

### 6.4. END OF LIFE



**WARNING:** the symbol on the instrument indicates that the appliance and its accessories must be collected separately and correctly disposed of.

## 7. TECHNICAL SPECIFICATIONS

### 7.1. TECHNICAL CHARACTERISTICS

Accuracy indicated as  $\pm[\% \text{reading} + (\text{number of digits} \times \text{resolution})]$  at  $23^{\circ}\text{C} \pm 5^{\circ}\text{C}$ ,  $< 80\% \text{RH}$

#### DC Voltage (Autorange)

| Range  | Resolution | Accuracy                                  | Input impedance | Protection against overcharge |
|--------|------------|---|-----------------|-------------------------------|
| 50.00V | 0.01V      | $\pm(1.0\% \text{rdg} + 2 \text{digits})$ | 1M $\Omega$     | 300VDC/ACrms                  |
| 300.0V | 0.1V       |   |                 |                               |

#### AC TRMS Voltage (Autorange)

| Range  | Resolution | Accuracy                                  | Bandwidth   | Protection against overcharge |
|--------|------------|---|-------------|-------------------------------|
| 50.00V | 0.01V      | $\pm(1.2\% \text{rdg} + 5 \text{digits})$ | 40Hz ÷ 1kHz | 300VDC/ACrms                  |
| 300.0V | 0.1V       |   |             |                               |

Input impedance: 1M $\Omega$

#### DC Current (Autorange)

| Range   | Resolution | Accuracy                                   | Protection against overcharge |
|---------|------------|--|-------------------------------|
| 300.0mA | 0.1mA      | $\pm(1.0\% \text{rdg} + 10 \text{digits})$ | 10ADC                         |
| 3,000A  | 0,001A     |  |                               |
| 10.00A  | 0.01A      | $\pm(3.0\% \text{rdg} + 10 \text{digits})$ |                               |

Influence of external magnetic field:  $< \pm 1.0 \text{mA}$  ; Influence of clamp jaw opening/closing:  $< \pm 1.0 \text{mA}$

#### AC TRMS Current (Autorange)

| Range   | Resolution | Accuracy                                  | Bandwidth   |
|---------|------------|---|-------------|
| 300.0mA | 0.1mA      | $\pm(1.0\% \text{rdg} + 5 \text{digits})$ | 50Hz ÷ 60Hz |
| 3,000A  | 0,001A     |   |             |
| 20.00A  | 0.01A      |   |             |

Protection against overcharge: 20Arms

#### Resistance and Continuity test (Autorange)

| Range           | Resolution      | Accuracy                                  | Buzzer        | Protection against overcharge |
|-----------------|-----------------|---|---------------|-------------------------------|
| 500.0 $\Omega$  | 0.1 $\Omega$    | $\pm(1.0\% \text{rdg} + 2 \text{digits})$ | $< 100\Omega$ | 300VDC/ACrms                  |
| 5.000k $\Omega$ | 0.001k $\Omega$ |   |               |                               |
| 50.00k $\Omega$ | 0.01k $\Omega$  |   |               |                               |
| 500.0k $\Omega$ | 0.1k $\Omega$   |   |               |                               |

#### 7.1.1. Electrical characteristics

Conversion type:

TRMS

Sampling frequency:

2 times per second

#### 7.1.2. Reference standards

Safety:

IEC/EN61010-1

EMC:

IEC/EN61326-1

Insulation:

double insulation

Pollution level:

2

Max operating altitude:

2000m (6562ft)

Measurement category:

CAT IV 300V

### 7.1.3. General characteristics

#### Mechanical characteristics

|                              |                               |
|------------------------------|-------------------------------|
| Dimensions (L x W x H):      | 206 x 76 x 34mm (8 x 3 x 1in) |
| Weight (batteries included): | 262g (9ounces)                |
| Clamp jaw opening:           | 23mm (1in)                    |
| Max. cable diameter:         | 23mm (1in)                    |
| Mechanical protection:       | IP20                          |

#### Power supply

|                                       |   |
|---------------------------------------|---|
| Battery type:                         | 2x1.5V batteries type AAA IEC LR03  |
| Low battery indication:               | symbol  on the display         |
| Battery duration (without backlight): | ca. 15 hours (DC current)<br>ca. 60 hours (AC current and voltage)<br>ca. 100 hours (DC voltage and resistance) |
| Auto Power OFF:                       | after 30 minutes' idling  |

#### Display

|                          |   |
|--------------------------|---|
| Characteristics:         | 4 LCD, 5000 dots plus decimal point and backlight |
| Out of range indication: | message <b>OL.</b> on the display                 |

## 7.2. ENVIRONMENT

### 7.2.1. Environmental conditions for use

|                        |                             |
|------------------------|-----------------------------|
| Reference temperature: | 23°C ± 5°C (73°F ± 41°F)    |
| Operating temperature: | 0°C ÷ 40°C (32°F ÷ 104°F)   |
| Operating humidity:    | ≤ 80%RH                     |
| Storage temperature:   | -10°C ÷ 60°C (13°F ÷ 140°F) |
| Storage humidity:      | <80%RH                      |

**This instrument satisfies the requirements of Low Voltage Directive 2014/35/EU (LVD) and of EMC Directive 2014/30/EU**  
**This instrument satisfies the requirements of European Directive 2011/65/EU (RoHS) and 2012/19/EU (WEEE).**

## 7.3. ACCESSORIES

### 7.3.1. Accessories provided

- Couple of test leads
- Carrying bag
- Batteries (not inserted)
- User manual

## 8. ASSISTANCE

### 8.1. WARRANTY CONDITIONS

This instrument is warranted against any material or manufacturing defect, in compliance with the general sales conditions. During the warranty period, defective parts may be replaced. However, the manufacturer reserves the right to repair or replace the product. The manufacturer declines any responsibility for injury to people or damage to property.

The warranty shall not apply in the following cases:

- Repair and/or replacement of accessories and battery (not covered by warranty).
- Repairs that may become necessary as a consequence of an incorrect use of the instrument or due to its use together with non-compatible appliances.
- Repairs that may become necessary as a consequence of improper packaging.
- Repairs which may become necessary as a consequence of interventions performed by unauthorized personnel.
- Modifications to the instrument performed without the manufacturer's explicit authorization.
- Use not provided for in the instrument's specifications or in the instruction manual.

The content of this manual cannot be reproduced in any form without the manufacturer's authorization.

**Our products are patented and our trademarks are registered. The manufacturer reserves the right to make changes in the specifications and prices if this is due to improvements in technology.**

### 8.2. ASSISTANCE

If the instrument does not operate properly, before contacting the After-sales Service, please check the conditions of the batteries and replace them, if necessary. Should the instrument still operate improperly, check that the product is operated according to the instructions given in this manual. Should the instrument be returned to the After-sales Service or to a Dealer, transport will be at the Customer's charge. However, shipment will be agreed in advance. A report will always be enclosed to a shipment, stating the reasons for the product's return. Only use original packaging for shipment; any damage due to the use of non-original packaging material will be charged to the Customer.