



# PQA819 – PQA820

UK  
CA  
CE

■ User manual



**TABLE OF CONTENTS**

<b>1. PRECAUTIONS AND SAFETY MEASURES</b>	<b>3</b>
1.1. Preliminary instructions	3
1.2. During use	4
1.3. After use	4
1.4. Definition of measurement (overvoltage) category	4
<b>2. GENERAL DESCRIPTION</b>	<b>5</b>
2.1. Foreword	5
2.2. Instrument functions	5
<b>3. PREPARATION FOR USE</b>	<b>6</b>
3.1. Initial checks	6
3.2. Instrument power supply	6
3.3. Storage	6
<b>4. NOMENCLATURE</b>	<b>7</b>
4.1. Instrument description	7
4.2. Keyboard description	7
4.3. Description of the LED	7
<b>5. INITIAL SETTINGS</b>	<b>8</b>
5.1. Setting the electrical system	8
5.2. Setting type of clamp	11
5.3. Setting the clamp's full scale	11
5.4. Setting the value of transformation ratio of VTs	11
5.5. Setting limits for voltage anomalies	11
5.6. Setting the integration period	11
5.7. Setting a programmed start and stop	12
5.8. Setting the instrument's date and time	12
<b>6. MEASURING PROCEDURES</b>	<b>13</b>
6.1. Connection in a single-phase system	13
6.2. Connection in a three-phase 3-wire system	14
6.3. Connection in a three-phase 4-wire system	15
<b>7. RECORDING OF ELECTRICAL PARAMETERS</b>	<b>16</b>
7.1. Starting recording	16
7.2. While recording	16
7.3. Stopping recording	16
<b>8. MEMORY MANAGERMENTS</b>	<b>17</b>
8.1. Clear data	17
<b>9. TRANSFERRING DATA TO THE MANAGEMENT SOFTWARE</b>	<b>18</b>
9.1. Transferring data via USB port	18
9.2. Transferring data via WiFi	18
9.3. Connection to iOS/Android devices through WiFi	18
<b>10. MAINTENANCE</b>	<b>19</b>
10.1. General information	19
10.2. Cleaning the instrument	19
10.3. End of life	19
<b>11. TECHNICAL SPECIFICATIONS</b>	<b>20</b>
11.1. Technical characteristics	20
11.2. Reference guidelines	21
11.3. General characteristics	21
11.4. Environmental conditions for use	21
11.5. Accessories	21
<b>12. APPENDIX – THEORETICAL OUTLINE</b>	<b>22</b>
12.1. Voltage Anomalies	22

---

12.2.	Voltage and current harmonics.....	23
12.2.1.	Limit values for harmonics .....	24
12.2.2.	Causes of the presence of harmonics.....	24
12.2.3.	Consequence of the presence of harmonics.....	25
12.3.	Definitions of power and power factor .....	26
12.3.1.	Conventions on powers and power factors .....	27
12.4.	Information on the measuring method.....	29
12.4.1.	Integration period .....	29
12.4.2.	Calculation of the power factor.....	29
<b>13.</b>	<b>SERVICE .....</b>	<b>30</b>
13.1.	Warranty conditions .....	30
13.2.	Service.....	30

## 1. PRECAUTIONS AND SAFETY MEASURES

The instrument has been designed in compliance with directive IEC/EN61010-1 relevant to electronic measuring instruments. For your safety and in order to prevent damaging the instrument, please carefully follow the procedures described in this manual and read all notes preceded by the symbol  with the utmost attention.

Before and after carrying out the measurements, carefully observe the following instructions:

- Do not carry out any voltage or current measurement in humid environments.
- Do not carry out any measurements in case gas, explosive materials or flammables are present, or in dusty environments.
- Avoid any contact with the circuit being measured if no measurements are being carried out.
- Avoid any contact with exposed metal parts, with unused measuring probes, circuits, etc.
- Do not carry out any measurement in case you find anomalies in the instrument such as deformation, breaks, substance leaks, absence of display on the screen, etc.

In this manual, and on the instrument, the following symbols are used:



Warning: observe the instructions given in this manual; improper use could damage the instrument or its components.



High voltage danger: electrical shock hazard.



Double-insulated meter



AC voltage or current



The voltage values indicated to the left of this symbol are referred to the ground

### 1.1. PRELIMINARY INSTRUCTIONS

- This instrument has been designed for use in environments of pollution degree 2.
- It can be used for **VOLTAGE** and **CURRENT** measurements on installations with overvoltage category CAT IV 300V AC to earth and rated voltage between inputs 415V AC
- Please take the standard safety precautions aimed at protecting you against dangerous electrical currents and protecting the instrument against incorrect use
- Only the accessories provided together with the instrument will guarantee safety standards. They must be in good conditions and be replaced with identical models, when necessary.
- Do not test circuits exceeding the specified current and voltage limits.
- Before connecting cables, alligator clips and clamps to the circuit being measured, check that the desired configuration has been set.

## 1.2. DURING USE

Please carefully read the following recommendations and instructions:



### CAUTION

Failure to comply with the caution notes and/or instructions may damage the instrument and/or its components or be a source of danger for the operator.

- When the instrument is connected to the circuit under test, do not touch any unused terminal.
- During current measurement, any other current near the clamp may affect measurement precision.
- When measuring current, always put the conductor as near as possible to the middle of the clamp jaw, to obtain the most accurate reading.

## 1.3. AFTER USE

- When measures are completed, switch off the instrument by pressing **ON/OFF** key.
- If the instrument is not to be used for a long time, please follow the instructions for storage described in § 3.3

## 1.4. DEFINITION OF MEASUREMENT (OVERVOLTAGE) CATEGORY

Standard “IEC/EN61010-1: Safety requirements for electrical equipment for measurement, control and laboratory use, Part 1: General requirements” defines what measurement category, commonly called overvoltage category, is. § 6.7.4: Measured circuits, reads: Circuits are divided into the following measurement categories:

- **Measurement category IV** is for measurements performed at the source of the low-voltage installation.  
*Examples are electricity meters and measurements on primary overcurrent protection devices and ripple control units.*
- **Measurement category III** is for measurements performed on installations inside buildings.  
*Examples are measurements on distribution boards, circuit breakers, wiring, including cables, bus-bars, junction boxes, switches, socket-outlets in the fixed installation, and equipment for industrial use and some other equipment, for example, stationary motors with permanent connection to fixed installation.*
- **Measurement category II** is for measurements performed on circuits directly connected to the low-voltage installation.  
*Examples are measurements on household appliances, portable tools and similar equipment.*
- **Measurement category I** is for measurements performed on circuits not directly connected to MAINS.  
*Examples are measurements on circuits not derived from MAINS, and specially protected (internal) MAINS-derived circuits. In the latter case, transient stresses are variable; for that reason, the standard requires that the transient withstand capability of the equipment is made known to the user*

## 2. GENERAL DESCRIPTION

### 2.1. FOREWORD

This manual refers to **PQA819** and **PQA820** models. In the whole manual, the word “instrument” generically indicates PQA820 model, unless otherwise indicated. The instrument allows for a totally new approach to electric measurements. Using computer-aided instruments allows analyzing a huge amount of data with a simplicity and speed impossible to obtain with any other system.

The differences between the models are listed in the following Table 1

Function description	PQA819	PQA820
Recording of neutral current		•
Recording of voltage anomalies (sags, swells)		•
Recording of voltage unbalance		•
Recording of voltage/current harmonics up to 49th order		•
Recording of apparent power		•
Recording of generated power/energy		•
Recording of generated power factor / $\text{Cos}\varphi$		•
Number of selectable parameters	44 (fixed)	383 (fixed)
Recording autonomy (days)	> 230 (@ IP=15min)	> 30 (@ IP=10min)

Table 1: Differences between model PQA819 and PQA820

### 2.2. INSTRUMENT FUNCTIONS

The instrument allows performing the following functions:

- A **real-time display** (with connection to PC and/or iOS/Android devices through APP **HTAnalysis**) of the values of the electric quantities of a single-phase or three-phase system with or without neutral and of the harmonic analysis of voltages and currents
- **Recording** (through the appropriate setting) over time of the values of AC/DC voltages, voltage unbalance (PQA820), voltage anomalies (sags, swells) with a resolution of 10ms (PQA820), AC/DC currents, neutral current (PQA820) of the values of the relevant harmonics (PQA820), THD% value, of the values of active, reactive and apparent powers (PQA820), of power factors and  $\text{cos}\varphi$ , of the values of active and reactive energies, where recording is intended as saving in the instrument's memory the values taken by the electrical quantities over time.



#### CAUTION

These terms will be used several times in this manual. We therefore invite you to try and immediately focus the distinctions between the definitions listed above.

### 3. PREPARATION FOR USE

#### 3.1. INITIAL CHECKS

Before shipping, the instrument has been checked from an electric as well as mechanical point of view. All possible precautions have been taken so that the instrument is delivered undamaged. However, we recommend generally checking the instrument in order to detect possible damage suffered during transport. In case anomalies are found, immediately contact the forwarding agent. We also recommend checking that the packaging contains all components indicated in § 11.5. In case of discrepancy, please contact the Dealer. In case the instrument should be replaced, please carefully follow the instructions given in § 13.

#### 3.2. INSTRUMENT POWER SUPPLY

The instrument may be supplied in two ways:

- **External supply:** red and yellow terminals (rated voltage field: 100 ÷ 415V, 50/60Hz).
- **Internal supply:** internal rechargeable batteries through red and yellow terminals.



#### CAUTION

- When recording, we recommend ALWAYS using the external supply
- If the external supply fails, the instrument automatically switches to the internal supply provided by rechargeable batteries
- **If the measurement involves the use of VT, the red and yellow power inputs must be connected to an external mains supply**

#### 3.3. STORAGE

In order to guarantee precise measurement, after a long storage time under extreme environmental conditions, wait for the instrument to come back to normal condition (see § 11.4).

## 4. NOMENCLATURE

### 4.1. INSTRUMENT DESCRIPTION

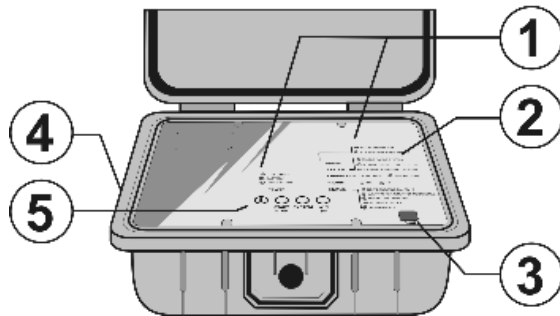

#### CAPTION:

1. Indication LEDs
2. Description of the indication LEDs
3. USB port
4. Voltage and Current inputs
5. Keyboard

Fig. 1: Instrument description

### 4.2. KEYBOARD DESCRIPTION

The keyboard includes the following keys:

- **ON/OFF:** pressing this key to switches the instrument on. Press the key approx. 2s to switches the instrument off. **If the instrument do not switch off press and hold this key for at least 5s**
- **START/STOP:** for manually starting and stopping recording (see § 7 and 7.3).
- **SYSTEM:** It allows for the selection of the electrical system (Single phase, Three phase 3-wire and 4-wire)
- **WiFi/RF:** it allows for the selection of the communication mode, WiFi or RF (only for the communication with other HT instruments).

### 4.3. DESCRIPTION OF THE LED

LED	Description
POWER	It describes the status and supply mode of the instrument: <b>Off:</b> instrument switched off <b>Flashing green:</b> instrument switched on supplied by internal batteries <b>Flashing red:</b> internal batteries almost flat
STATUS	It described the instrument status: <b>Off:</b> No recording in progress <b>Flashing green:</b> Recording in progress <b>Green:</b> Instrument waiting to start recording. Recording will always start at the beginning of the minute after the <b>START</b> button has been pressed / receipt of the start recording control <b>Flashing red:</b> Memory full <b>Red:</b> Internal error – use the management software to identify the type of malfunction. Some of them may also prevent recording.
RF/WiFi	It described what communication mode is currently set in the instrument: <b>Off:</b> WiFi mode <b>Flashing green:</b> RF mode (only for connection with other HT instruments)
CONNECTION	It indicates if a WiFi or RF connection is active (according to the communication mode set)
SYSTEM	It indicates the electrical system currently set: <b>Off:</b> Single-phase mode <b>Flashing green:</b> Three-phase without neutral mode <b>Green:</b> Three-phase with neutral mode
ERROR	It indicates possible connection errors: <b>Off:</b> No error detected <b>Flashing red:</b> Phase sequence incorrect <b>Red:</b> One of the active powers measured by the instrument is negative.

Table 2: Description of LEDs

## 5. INITIAL SETTINGS



### CAUTION

The instrument may be configured only through the relevant management software, except for the selection of the electrical system, which may also be performed through the **SYSTEM** key in the instrument's keyboard

### 5.1. SETTING THE ELECTRICAL SYSTEM

This parameter allows selecting the type of electrical system to be analyzed. It is possible to select the electrical system through the **SYSTEM** button in the instrument's keyboard. Following configurations are available:

- Single-phase system
- Three-phase system without neutral (3-wires)
- Three-phase system with neutral (4-wires)

Each electrical system is associated with a list of parameters automatically recorded by the instrument (**not modifiable**).

SYMBOL	DESCRIPTION
V1	RMS value of voltage of Phase 1 or DC
Freq.	Mains frequency
I1	RMS value of Phase 1 current or DC
THDV1%,	Harmonic distortion percentage factor of Phase 1 voltage
DCV1, Har1V1, ,Har49V1	Voltage harmonics of Phase 1 (PQA820)
THDI1%	Harmonic distortion percentage factor of Phase 1 current
DCI1, Har1I1, ,Har49I1	Current harmonics of Phase 1 (PQA820)
P1+	Absorbed active power Phase 1
Ea1+	Absorbed active energy Phase 1
Q1i+	Absorbed inductive reactive power Phase 1
Er1i+	Absorbed inductive reactive energy Phase 1
Q1c+	Absorbed capacitive reactive power Phase 1
Er1c+	Absorbed capacitive reactive energy Phase 1
S1+	Absorbed apparent power Phase 1 (PQA820)
Es1+	Absorbed apparent energy Phase 1 (PQA820)
Pf1i+	Value of the absorbed inductive power factor of Phase 1
dPf1i+ +	Value of the absorbed inductive $\cos\varphi$ of Phase 1
Pf1c+	Value of the absorbed capacitive power factor of Phase 1
dPf1c+	Value of the absorbed capacitive $\cos\varphi$ of Phase 1
P1-	Generated active power Phase 1 (PQA820)
Ea1-	Generated active energy Phase 1 (PQA820)
Q1i-	Generated inductive reactive power Phase 1 (PQA820)
Er1i-	Generated inductive reactive energy Phase 1 (PQA820)
Q1c-	Generated capacitive reactive power Phase 1 (PQA820)
Er1c-	Generated capacitive reactive energy Phase 1 (PQA820)
S1-	Generated apparent power Phase 1 (PQA820)
Es1-	Generated apparent energy Phase 1 (PQA820)
Pf1i-	Value of the generated inductive power factor of Phase 1 (PQA820)
dPf1i-	Value of the generated inductive $\cos\varphi$ of Phase 1 (PQA820)
Pf1c-	Value of the generated capacitive power factor of Phase 1 (PQA820)
dPf1c-	Value of the generated capacitive $\cos\varphi$ of Phase 1 (PQA820)

Table 3: List of the parameters automatically recorded for a single-phase system

SYMBOL	DESCRIPTION
V1PE, V2PE, V3PE	RMS value of voltage of Phase 1, Phase 2, Phase 3 with respect to PE
V12, V23, V31	RMS value of delta voltages
Freq.	Mains frequency
I1, I2, I3	RMS value of current of Phase 1, Phase 2, Phase 3 neutral
THDV1%, THDV2%, THDV3%	Harmonic distortion percentage factor of voltage of Phase 1, Phase 2, Phase 3
DCVx, Har1Vx, ,Har49Vx	(x=1,2,3) - Voltage harmonics of Phase 1, Phase 2, Phase 3 (PQA820)
THDI1%, THDI2%, THDI3%	Harmonic distortion percentage factor of current of Phase 1, Phase 2, Phase 3
DCIx, Har1Ix, ,Har49Ix	(x=1,2,3) - Current harmonics of Phase 1, Phase 2, Phase 3 (PQA820)
u2, uo	Unbalance of voltages - Percentage value of the negative sequence (PQA820)
uo	Unbalance of voltages - Percentage value of the zero sequence (PQA820)
Pt+, P1+, P2+, P3+	Absorbed active power Total, Phase 1, Phase 2, Phase 3
Eat+, Ea1+, Ea2+, Ea3+	Absorbed active energy Total, Phase 1, Phase 2, Phase 3
Qti+, Q1i+, Q2i+, Q3i+	Absorbed inductive reactive power Total, Phase 1, Phase 2, Phase 3
Erti+, Er1i+, Er2i+, Er3i+	Absorbed inductive reactive energy Total, Phase 1, Phase 2, Phase 3
Qtc+, Q1c+, Q2c+, Q3c+	Absorbed capacitive reactive power Total, Phase 1, Phase 2, Phase 3
Ertc+, Er1c+, Er2c+, Er3c+	Absorbed capacitive reactive energy Total, Phase 1, Phase 2, Phase 3
St+, S1+, S2+, S3+	Absorbed apparent power Total, Phase 1, Phase 2, Phase 3 (PQA820)
Est+, Es1+, Es2+, Es3+	Absorbed apparent energy Total, Phase 1, Phase 2, Phase 3 (PQA820)
Pfti+, Pf1i+, Pf2i+, Pf3i+	Values of the absorbed inductive power factors Total, Phase 1, Phase 2, Phase 3
dPfti+, dPf1i+, dPf2i+, dPf3i+	Values of the absorbed inductive $\cos\phi$ Total, Phase 1, Phase 2, Phase 3
Pftc+, Pf1c+, Pf2c+, Pf3c+	Values of the absorbed capacitive power factors Total, Phase 1, Phase 2, Phase 3
dPftc+, dPf1c+, dPf2c+, dPf3c+	Values of the absorbed capacitive $\cos\phi$ Total. Phase 1, Phase 2, Phase 3
Pt-, P1-, P2-, P3-	Generated active power Total, Phase 1, Phase 2, Phase 3 (PQA820)
Eat-, Ea1-, Ea2-, Ea3-	Generated active energy Total, Phase 1, Phase 2, Phase 3 (PQA820)
Qti-, Q1i-, Q2i-, Q3i-	Generated inductive reactive power Total, Phase 1, Phase 2, Phase 3 (PQA820)
Erti-, Er1i-, Er2i-, Er3i-	Generated inductive reactive energy Total, Phase 1, Phase 2, Phase 3 (PQA820)
Qtc-, Q1c-, Q2c-, Q3c-	Generated capacitive reactive power Total, Phase 1, Phase 2, Phase 3 (PQA820)
Ertc-, Er1c-, Er2c-, Er3c-	Generated capacitive reactive energy Total, Phase 1, Phase 2, Phase 3(PQA820)
St-, S1-, S2-, S3-	Generated apparent power Total, Phase 1, Phase 2, Phase 3 (PQA820)
Est-, Es1-, Es2-, Es3-	Generated apparent energy Total, Phase 1, Phase 2, Phase 3 (PQA820)
Pfti-, Pf1i-, Pf2i-, Pf3i-	Generated inductive power factors Total, Phase 1, Phase 2, Phase 3 (PQA820)
dPfti-, dPf1i-, dPf2i-, dPf3i-	Generated inductive $\cos\phi$ Total, Phase 1, Phase 2, Phase 3 (PQA820)
Pftc-, Pf1c-, Pf2c-, Pf3c-	Generated capacitive power factors Total, Phase 1, Phase 2, Phase 3 (PQA820)
dPftc-, dPf1c-, dPf2c-, dPf3c-	Generated capacitive $\cos\phi$ Total, Phase 1, Phase 2, Phase 3 (PQA820)

Table 4: List of the parameters automatically recorded for a three-phase 3-wire system

SYMBOL	DESCRIPTION
V1, V2, V3	RMS value of voltage of Phase 1, Phase 2, Phase 3
V12, V23, V31	RMS value of delta voltages
Freq.	Mains frequency
I1, I2, I3	RMS value of current of Phase 1, Phase 2, Phase 3
IN	Neutral current (PQA820)
THDV1%, THDV2%, THDV3%	Harmonic distortion percentage factor of Phase 1, Phase 2, Phase 3 voltage
DCVx, Har1Vx, ,Har49Vx	(x=1,2,3) - Voltage harmonics of Phase 1, Phase 2, Phase 3 (PQA820)
THDI1%, THDI2%, THDI3%	Harmonic distortion percentage factor of Phase 1, Phase 2, Phase 3 current
DCIx, Har1Ix, ,Har49Ix	(x=1,2,3) - Current harmonics of Phase 1, Phase 2, Phase 3 (PQA820)
u2, uo	Unbalance of voltages - Percentage value of the negative sequence (PQA820)
uo	Unbalance of voltages - Percentage value of the zero sequence (PQA820)
Pt+, P1+, P2+, P3+	Absorbed active power Total, Phase 1, Phase 2, Phase 3
Eat+, Ea1+, Ea2+, Ea3+	Absorbed active energy Total, Phase 1, Phase 2, Phase 3
Qti+, Q1i+, Q2i+, Q3i+	Absorbed inductive reactive power Total, Phase 1, Phase 2, Phase 3
Erti+, Er1i+, Er2i+, Er3i+	Absorbed inductive reactive energy Total, Phase 1, Phase 2, Phase 3
Qtc+, Q1c+, Q2c+, Q3c+	Absorbed capacitive reactive power Total, Phase 1, Phase 2, Phase 3
Ertc+, Er1c+, Er2c+, Er3c+	Absorbed capacitive reactive energy Total, Phase 1, Phase 2, Phase 3
St+, S1+, S2+, S3+	Absorbed apparent power Total, Phase 1, Phase 2, Phase 3 (PQA820)
Est+, Es1+, Es2+, Es3+	Absorbed apparent energy Total, Phase 1, Phase 2, Phase 3 (PQA820)
Pfti+, Pf1i+, Pf2i+, Pf3i+	Values of the absorbed inductive power factors Total, Phase 1, Phase 2, Phase 3
dPfti+, dPf1i+, dPf2i+, dPf3i+	Values of the absorbed inductive cos $\varphi$ Total, Phase 1, Phase 2, Phase 3
Pftc+, Pf1c+, Pf2c+, Pf3c+	Values of the absorbed capacitive power factors Total, Phase 1, Phase 2, Phase 3
dPftc+, dPf1c+, dPf2c+, dPf3c+	Values of the absorbed capacitive cos $\varphi$ Total. Phase 1, Phase 2, Phase 3
Pt-, P1-, P2-, P3-	Generated active power Total, Phase 1, Phase 2, Phase 3 (PQA820)
Eat-, Ea1-, Ea2-, Ea3-	Generated active energy Total, Phase 1, Phase 2, Phase 3 (PQA820)
Qti-, Q1i-, Q2i-, Q3i-	Generated inductive reactive power Total, Phase 1, Phase 2, Phase 3 (PQA820)
Erti-, Er1i-, Er2i-, Er3i-	Generated inductive reactive energy Total, Phase 1, Phase 2, Phase 3 (PQA820)
Qtc-, Q1c-, Q2c-, Q3c-	Generated capacitive reactive power Total, Phase 1, Phase 2, Phase 3 (PQA820)
Ertc-, Er1c-, Er2c-, Er3c-	Generated capacitive reactive energy Total, Phase 1, Phase 2, Phase 3 (PQA820)
St-, S1-, S2-, S3-	Generated apparent power Total, Phase 1, Phase 2, Phase 3 (PQA820)
Est-, Es1-, Es2-, Es3-	Generated apparent energy Total, Phase 1, Phase 2, Phase 3 (PQA820)
Pfti-, Pf1i-, Pf2i-, Pf3i-	Generated inductive power factors Total, Phase 1, Phase 2, Phase 3 (PQA820)
dPfti-, dPf1i-, dPf2i-, dPf3i-	Generated inductive cos $\varphi$ Total, Phase 1, Phase 2, Phase 3 (PQA820)
Pftc-, Pf1c-, Pf2c-, Pf3c-	Generated capacitive power factors Total, Phase 1, Phase 2, Phase 3 (PQA820)
dPftc-, dPf1c-, dPf2c-, dPf3c-	Generated capacitive cos $\varphi$ Total, Phase 1, Phase 2, Phase 3 (PQA820)

Table 5: List of the parameters automatically recorded for a three-phase 4-wire system



### CAUTION

The connections to the instrument's inputs must be consistent with the type of system selected. For further information on the settings of this parameter, please refer to the on-line guide of the management software

## 5.2. SETTING TYPE OF CLAMP

The instrument is capable of managing two types of clamp meter:

- **STD**: standard clamp with iron core
- **Flex**: flexible clamp

It is also possible to differentiate the type of clamp used for phase and neutral current with **independent setting** of used full scales.

The type of clamp **selected must always be consistent** with the type of clamp actually used. For further information on the settings of this parameter, please refer to the on-line guide of the management software

## 5.3. SETTING THE CLAMP'S FULL SCALE

This parameter allows selecting the full scale of the clamp used. It is possible to differentiate the full scale of the clamp used for measuring phase and neutral current. For the “**Flex**” clamp type it is possible to select **100A and 1000A values only**. The **selected full scale must always be consistent** with the full scale actually used. For further information on the settings of this parameter, please refer to the on-line guide of the management software.

## 5.4. SETTING THE VALUE OF TRANSFORMATION RATIO OF VTS

The instrument allows interfacing also with possible Voltage Transformers (VT) found in the system to be measured and displays the value of the voltages found on the primary transformers. To this aim it is necessary to set the value of the transformation ratio of the voltage transformers installed. Selectable range is **1 ÷ 3999**

## 5.5. SETTING LIMITS FOR VOLTAGE ANOMALIES

The instrument allows the voltage anomalies (sags, swells) recording with preliminary setting of a nominal voltage value (depending on the type of selected system) and the minimum and maximum limit thresholds with percentage values selected between **1%** and **30%**. For further information on the settings of this parameter, please refer to the on-line guide of the management software and § 12.1

## 5.6. SETTING THE INTEGRATION PERIOD

The value of this parameter determines every how many seconds the values of all selected quantities will be archived in the instrument's memory (see § 12.4). Available values: **5s, 10s, 30s, 1min, 2min, 5min, 10min, 15min, 60min**

For further information on the settings of this parameter, please refer to the on-line guide of the management software.

### 5.7. SETTING A PROGRAMMED START AND STOP

Through these parameters it is possible to set the start/stop modes of a recording. In detail:

<b>START:MAN</b>	Recording of all selected quantities will be started <b><u>at the beginning of the first minute</u></b> after the <b>START/STOP</b> key has been pressed by the operator (see § 7).
<b>STOP:MAN</b>	Recording of all selected quantities will be manually stopped by the operator by pressing the <b>START/STOP</b> key (see § 7.3).
<b>START:AUTO</b> <b>STOP:AUTO</b>	Recording of all selected quantities will be started/stopped at the set date and time. <b><u>To start recording, the operator will have to press the START/STOP key</u></b> to set the instrument to Stand-By waiting for the set start date to be reached (see § 7).

For further information on the settings of this parameter, please refer to the on-line guide of the management software.

### 5.8. SETTING THE INSTRUMENT'S DATE AND TIME

It is possible to set the instrument's date and time by sending to it the date and time of the device on which the management software has been installed.

For further information on the settings of this parameter, please refer to the on-line guide of the management software.

## 6. MEASURING PROCEDURES

### 6.1. CONNECTION IN A SINGLE-PHASE SYSTEM



#### CAUTION

- The maximum rated voltage between inputs is 415V AC, CAT IV 300V to earth. Do not connect the instrument to voltages exceeding the limits given in this manual
- The rated supply voltage of the instrument (red-yellow terminals) must be within the range: 100 ÷ 415V, 50/60Hz

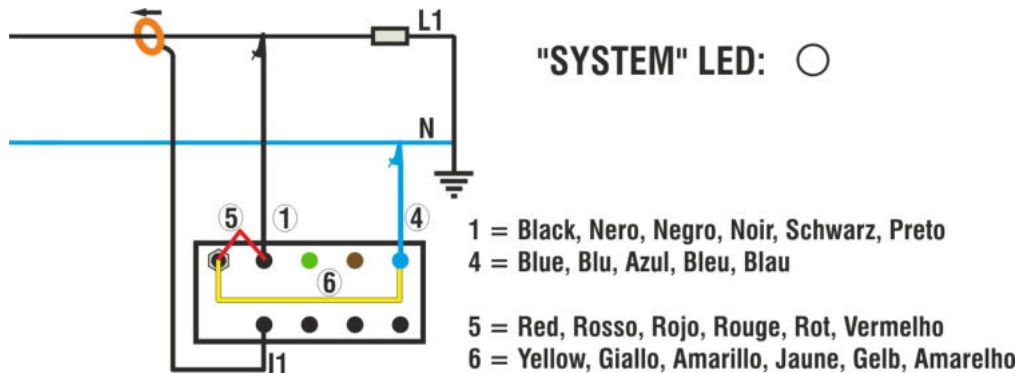

Fig. 2: Connection of the instrument to a single-phase system



#### CAUTION

If possible, cut out the power supply of the electrical system to be measured before connecting the instrument.

1. Check and, if necessary, change the basic settings of the instrument (see § 5). In particular set the **Single-phase** mode.
2. Connect the supply terminals (red and yellow) respecting the connections indicated in Fig. 2
3. Connect the cables of the L1-N voltages, respecting the connections indicated in the Fig. 2
4. If you want to measure current and power, connect the clamp meter to the phase conductor, **respecting the direction indicated on the clamp** and the connections indicated in the Fig. 2
5. Connect the electrical system to be measured to voltage in case the system has been momentarily put out of order to connect the instrument.
6. Check that the **Error** LED is off. In case it is on steady, check that the clamp meter is connected respecting the direction indicated.
7. In case a USB or WiFi connection (see § 9) with a device is active on which a management software is installed, the values of the available electrical quantities will appear on the device's display. For further information, please refer to the on-line guide of the management software.
8. If you want to record:
  - Check and, if necessary, change the values of the basic parameters (see § 5)
  - To start recording, press the **START/STOP** key (see § 7).

## 6.2. CONNECTION IN A THREE-PHASE 3-WIRE SYSTEM



### CAUTION

- The maximum rated voltage between inputs is 415V AC, CAT IV 300V to earth. Do not connect the instrument to voltages exceeding the limits given in this manual
- The rated supply voltage of the instrument (red-yellow terminals) must be within the range: 100 ÷ 415V, 50/60Hz

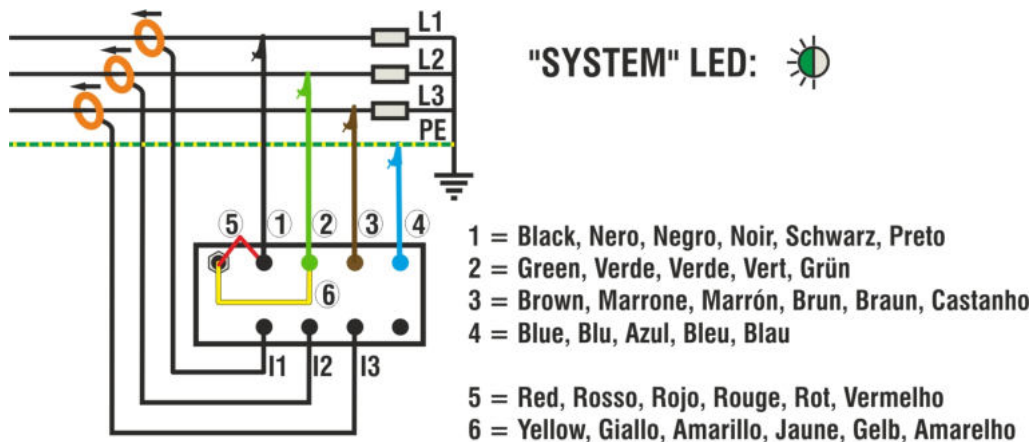

Fig. 3: Connection of the instrument to a three-phase 3-wire system



### CAUTION

If possible, cut out the power supply of the electrical system to be measured before connecting the instrument.

1. Check and, if necessary, change the basic settings of the instrument (see § 5). In particular, it will be certainly necessary to set the **Three-phase 3-wire** mode.
2. Connect the supply terminals (red and yellow) respecting the connections indicated in the Fig. 3
3. Connect the cables of the phase voltages L1, L2 e L3, respecting the connections indicated in the Fig. 3. Connect the blue cable to the protective conductor.
4. If you want to measure currents and powers, connect the clamp meters to the phase conductors, **respecting the direction indicated on the clamps** and the connections indicated in the Fig. 3
5. Connect the electrical system to be measured to voltage in case the system has been momentarily put out of order.
6. Check that the **Error** LED is off. In case it is:
  - On and flashing → check that the voltages respect the correct phase sequence
  - On steady → check that the clamp meter is connected respecting the direction indicated
7. In case a USB or WiFi connection (see § 9) with a device is active on which a management software is installed, the values of the available electrical quantities will appear on the device's display. For further information, please refer to the on-line guide of the management software
8. If you want to record:
  - Check and, if necessary, change the values of the basic parameters (see § 5)
  - To start recording, press the **START/STOP** key (see § 7)

### 6.3. CONNECTION IN A THREE-PHASE 4-WIRE SYSTEM



#### CAUTION

- The maximum rated voltage between inputs is 415V AC, CAT IV 300V to earth. Do not connect the instrument to voltages exceeding the limits given in this manual
- The rated supply voltage of the instrument (red-yellow terminals) must be within the range: 100 ÷ 415V, 50/60Hz

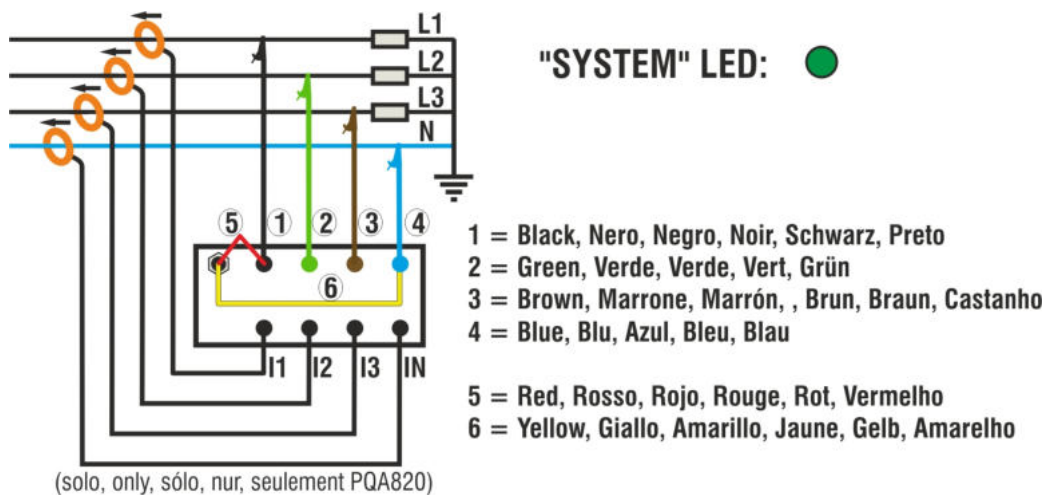

Fig. 4: Connection of the instrument to a three-phase 4-wire system



#### CAUTION

If possible, cut out the power supply of the electrical system to be measured before connecting the instrument.

1. Check and, if necessary, change the basic settings of the instrument (see § 5). In particular, it will be certainly necessary to set the **Three-phase 4-wire** mode
2. Connect the supply terminals (red and yellow) respecting the connections indicated in the Fig. 4
3. Connect the cables of the phase voltages L1, L2, L3, respecting the connections indicated in the Fig. 4. Connect the blue cable to the system's neutral.
4. If you want to measure currents and powers, connect the clamp meters to the phase conductors, **respecting the direction indicated on the clamps** and the connections indicated in the Fig. 4
5. Connect the electrical system to be measured to voltage in case the system has been momentarily put out of order.
6. Check that the **Error** LED is off. In case it is:
  - On and flashing →, check that the voltages respect the correct phase sequence
  - On steady → check that the clamp meter is connected respecting the direction indicated
7. In case a USB or WiFi connection (see § 9) with a device is active on which a management software is installed, the values of the available electrical quantities will appear on the device's display. For further information, please refer to the on-line guide of the management software.
8. If you want to record:
  - Check and, if necessary, change the values of the basic parameters (see § 5)
  - To start recording, press the **START/STOP** key (see § 7)

## 7. RECORDING OF ELECTRICAL PARAMETERS

### 7.1. STARTING RECORDING

Recording can be started MANUALLY or AUTOMATICALLY. Once the setting phase has been completed **and after quitting the menu mode**, the instrument will start recording by following logic illustrated hereunder:

- ✓ MANUAL: Recording will start **at the beginning of the minute** after the **START/STOP** button has been pressed.
- ✓ AUTO: **If the operator has pressed the START/STOP key**, the instrument will wait until the date and time set for recording start have been reached and then will start recording. **If the operator does not press the START/STOP key, instead, recording will NEVER start.**

While the instrument is waiting to reach the starting date and time, the **Status** LED turns on green steady.



### CAUTION

When recording, we recommend ALWAYS using the external supply.

- Before starting recording, the operator should make a real-time preliminary evaluation of the system's situation, decide what to record and consistently set the instrument
- To help the user in the setting phase, the instrument has been pre-set with a **general 4-wire configuration** for each selected electrical system, which should be suitable for most of the cases in which the instrument is used
- Pressing the **START/STOP** key starts recording the selected quantities according to the specifications set in the menu (see § 5.7)
- Since the default value of the integration periods is set to **15min**, the instrument will internally cumulate data in the temporary memory for that time. Once that time interval has elapsed, the instrument will process the results saved in the temporary memory and will save in the instrument's memory the first series of values relevant to recording
- Therefore, assuming an integration period of 15min has been set, the duration of recording will have to be **at least of 15 minutes** in order to produce a series of recorded values which can therefore be transferred through the management software
- In case recording is stopped before the selected integration period has completely elapsed, the data cumulated in the temporary measurement will not be processed and their relevant series of data will not be transferred to the instrument's memory.

### 7.2. WHILE RECORDING

While recording it is possible to display the following data using the management software:

- Starting date and time of recording
- Value of the integration period
- Number of elapsed integration periods
- Recording duration
- Number of voltage anomalies detected

### 7.3. STOPPING RECORDING

Press the **START/STOP** key to stop recording.

## 8. MEMORY MANAGERMENTS

The instrument has approximately 8MB for storing the values of the measured quantities. Through the management software it is possible to receive information about the residual recording duration compatible with the residual memory space and the settings made on the instrument itself.

For further information on this issue, please refer to the on-line guide of the management software.



### CAUTION

All saved data can be seen only after transferring them onto a PC using the management software

### 8.1. CLEAR DATA

It is possible to clear the whole instrument's memory by using the following procedure:

- Switch off the instrument with **ON/OFF** key
- Press and hold the **SYSTEM** key while switching on the instrument again by means of the **ON/OFF** key.

The instrument will sound to confirm that the memory has been cleared.

## 9. TRANSFERRING DATA TO THE MANAGEMENT SOFTWARE

The connection between the instrument and the management may occur through:

- USB port by means connection with USB cable
- WiFi connection



### CAUTION

- It is not possible to transfer data while recording
- The selected port must **NOT** be engaged by other devices or applications (e.g. a mouse, a modem, etc.)
- Before making the connection, it is necessary to select WiFi communication or the COM port used in the management software

To transfer data from the instrument onto a PC, please use the following procedure:

### 9.1. TRANSFERRING DATA VIA USB PORT

1. Switch on the instrument.
2. Connect the instrument's USB port with a port of the device on which the management software has been installed.
3. Start the management software and select the downloaded data mode (for further information on the settings of this parameter, please refer to the on-line guide of the management software)

### 9.2. TRANSFERRING DATA VIA WIFI



### CAUTION

The transfer requires the use of a PC with an active and operative WiFi connection (type integrated inside the PC or by installation of an USB-WiFi adapter available in the market **and can't be supplied under any circumstances by HT ITALIA**)

1. Activate the WiFi connection on the target PC (ex: by using a WiFi key installed and connected to a USB port, open the "Connect to a network" window by clicking the network icon in the notification area (typically in the bottom right corner of the PC screen), select the network "PQA820-xx", click "Connect" and wait for the confirmation of the connection)
2. Switch on the instrument.
3. Press the **WiFi/RF** key on the instrument in order to activate communication (RF/WiFi LED off).
4. Start the management software and select the downloaded data mode with WiFi (for further information on the settings of this parameter, please refer to the on-line guide of the management software)

### 9.3. CONNECTION TO IOS/ANDROID DEVICES THROUGH WIFI

The instrument can be connected remotely via WiFi connection to a Android/iOS smartphones and/or tablets for the transfer of measurement data using the APP HT Analysis. Proceed as follows:

1. Download and install the HT Analysis on the desired remote device (Android/iOS)
2. Put the instrument in data transfer mode to a PC (see § 9.2)
3. Take reference to the HT Analysis instruction for the management operation

## 10. MAINTENANCE

### 10.1. GENERAL INFORMATION

While using and storing the instrument, carefully observe the recommendations listed in this manual in order to prevent possible damage or danger during use:

- Do not use the instrument in environments with high humidity levels or high temperatures
- Do not expose to direct sunlight
- Always switch off the instrument after use.

### 10.2. CLEANING THE INSTRUMENT

Use a soft and dry cloth to clean the instrument. Never use wet cloths, solvents, water, etc.

### 10.3. END OF LIFE



**CAUTION:** the symbol on the instrument indicates that the appliance and its accessories must be collected separately and correctly disposed of.



## 11. TECHNICAL SPECIFICATIONS

### 11.1. TECHNICAL CHARACTERISTICS

Accuracy indicated as  $\pm[\%rdg + (\text{num. dgt} * \text{resolution})]$  referred to  $23^{\circ}\text{C} \pm 5^{\circ}\text{C}$ ,  $< 75\%RH$

#### DC Voltage [Phase (+) – Neutral (-)]

Range [V]	Resolution [V]	Accuracy
10.0 ÷ 265.0	0.1	$\pm(0.7\%rdg + 0.4V)$

Voltage values  $< 10.0V$  are zeroed

#### AC TRMS Voltage (Phase-Neutral, Phase-PE)

Range [V]	Frequency [Hz]	Resolution [V]	Accuracy
10.0 ÷ 265.0	42.5 ÷ 65.0Hz	0.1	$\pm(0.5\%rdg + 0.2V)$

Maximum crest factor = 1.5, Voltage values  $< 10.0V$  are zeroed

#### AC TRMS Voltage (Phase- Phase)

Range [V]	Frequency [Hz]	Resolution [V]	Accuracy
50.0 ÷ 460	42.5 ÷ 65.0Hz	0.1	$\pm(1.0\%rdg + 0.2V)$

Maximum crest factor = 1.5, Voltage values  $< 10.0V$  are zeroed

#### Voltage anomalies (Phase-Neutral, Phase-PE) (only PQA820)

Range [V]	Resolution [V]	Resolution [ms]	Accuracy [V]	Accuracy [ms]
15.0 ÷ 265.0	0.2	10ms	$\pm(1.0\%rdg + 2dgt)$	$\pm \frac{1}{2}$ cycle

#### DC Current – STD transducers clamps

Range [mV]	Resolution [mV]	Accuracy	Overload protection
5.0 ÷ 219.9	1	$\pm(0.7\%rdg + 1mV)$	10V
220.0 ÷ 999.9		$\pm 0.7\%rdg$	

Current values correspondent to a voltage  $< 5mV$  are zeroed

#### AC TRMS Current – STD transducers clamps

Range [mV]	Frequency [Hz]	Resolution [mV]	Accuracy
5.0 ÷ 219.9	42.5 ÷ 65.0	1	$\pm(0.5\%rdg + 0.6mV)$
220.0 ÷ 999.9			$\pm(0.5\%rdg)$

Current values correspondent to a voltage  $< 5mV$  are zeroed

#### AC TRMS Current – Flex transducers clamps (100A AC Range – 85 $\mu$ V/A)

Range [mV]	Frequency [Hz]	Resolution	Accuracy	Overload protection
0.085 ÷ 8.50	42.5 ÷ 65.0	8.5 $\mu$ V	$\pm(0.5\%rdg + 0.007mV)$	10V

Maximum crest factor = 1.5, Current values  $< 1A$  are zeroed

#### AC TRMS Current – Flex transducers clamps (1000A AC Range – 85 $\mu$ V/A)

Range [mV]	Frequency [Hz]	Resolution	Accuracy	Overload protection
0.425 ÷ 85.0	42.5 ÷ 65.0	85 $\mu$ V	$\pm(0.5\%rdg + 0.15mV)$	10V

Maximum crest factor = 1.5; Current values  $< 5A$  are zeroed

#### Frequency

Range [Hz]	Resolution [Hz]	Accuracy
42.5 ÷ 65.0	0.1	$\pm(0.2\%rdg + 0.1Hz)$

#### DC Power – (Vmeas > 200V)

Clamp FS [A]	Range [W]	Resolution [W]	Accuracy
1 < FS ≤ 10	0.000k ÷ 9.999k	0.001k	$\pm(1.0\%rdg + 5W)$
	10.00k ÷ 99.99k	0.01k	$\pm(1.0\%rdg + 50W)$
10 < FS ≤ 200	0.00k ÷ 99.99k	0.01k	$\pm(1.0\%rdg + 50W)$
	100.0k ÷ 999.9k	0.1k	$\pm(1.0\%rdg + 500W)$
200 < FS ≤ 1000	0.0k ÷ 999.9k	0.1k	$\pm(1.0\%rdg + 0.5kW)$
	1000k ÷ 9999k	1k	$\pm(1.0\%rdg + 5kW)$

Vmeas = Voltage in which the power is measured

**AC Power/Energy – (Vmeas > 200V, Pf=1)**

Clamp FS [A]	Range [W] [Wh]	Resolution [W] [Wh]	Accuracy
1 < FS ≤ 10	0.000k ÷ 9.999k	0.001k	±(0.7%rdg + 3W/Wh)
	10.00k ÷ 99.99k	0.01k	±(0.7%rdg+30W/Wh)
10 < FS ≤ 200	0.00k ÷ 99.99k	0.01k	±(0.7%rdg+30W/Wh)
	100.0k ÷ 999.9k	0.1k	±(0.7%rdg+300W/Wh)
200 < FS ≤ 1000	0.0k ÷ 999.9k	0.1k	±(0.7%rdg+0.3kW/kWh)
	1000k ÷ 9999k	1k	±(0.7%rdg+3kW/kWh)

Vmeas = Voltage in which the power is measured

**Power factor and Cosφ**

Range	Resolution (°)	Accuracy (°)
0.20 ÷ 0.50	0.01	0.6
0.50 ÷ 0.80		0.7
0.80 ÷ 1.00		1.0

**Voltage / Current harmonics (recording only for PQA820)**

Range	Max resolution	Accuracy
DC ÷ 25 <sup>th</sup>	0.3V / 0.1%FS clamp	±(5.0%rdg + 2dgt)
26 <sup>th</sup> ÷ 33 <sup>th</sup>		±(10%rdg + 2dgt)
34 <sup>th</sup> ÷ 49 <sup>th</sup>		±(15%rdg + 2dgt)

The harmonics will be zeroed under the following conditions

- > DC: if the value of DC < 0.5% of the value of the fundamental or if the DC value < 0.5% of the FS clamp
- > 1st harmonic: if the value of the 1st harmonic < 0.5% of the FS clamp
- > 2nd ÷ 49th harmonic: if the value of harmonic < 0.5% of the value of the fundamental or if < 0.5% of the FS clamp

**11.2. REFERENCE GUIDELINES**

Safety / EMC:	IEC/EN61010-1 / IECEN61326-1
Quality of voltage supply:	EN50160 (voltage / THDV%) and harmonics (PQA820)
Insulation:	double insulation
Pollution level:	2
Max. height of use:	2000m (6562ft)
Measurement category:	CAT IV 300V AC (to ground), Max 460V between inputs

**11.3. GENERAL CHARACTERISTICS**
**Mechanical characteristics:**

Dimensions (L x W x H):	245 x 210 x 110mm (10 x 8 x 4in) / Weight: 1.5kg (3lv)
Mechanical protection:	IP65

**Power supply**

Internal power supply (rechargeable battery):	>6 hours (WiFi on) ; >15 hours (WiFi off)
External power supply:	Ing. Red-Yellow: 100 ÷ 415V, 50/60Hz 45mA@100V, 30mA@230V, 20mA@415V

**Measurement, memory and Interface**

Number of samples per period:	128, (64 in "Real Time" connection)
Max. simultaneous recordable parameters:	383 (PQA820), 44 (PQA819)
Max. recordable voltage anomalies:	65530 (PQA820)
Integration period:	5, 10, 30s, 1, 2, 5, 10, 15, 60min
Recording autonomy:	> 30 days (@ IP = 10 minutes) (PQA820) > 230 days (@ IP = 15 minutes) (PQA819)
Memory:	8Mbyte
Communication interface (PC/Tablets):	USB (PC only) / WiFi

**11.4. ENVIRONMENTAL CONDITIONS FOR USE**

Reference temperature:	23°C ± 5°C (73°F ± 41°F)
Operating temperature:	0°C ÷ 40 °C (32°F ÷ 104°F)
Allowable relative humidity:	<80%RH
Storage temperature:	-10°C ÷ 60°C (14°F ÷ 140°F)
Storage humidity:	<80%RH

This instrument complies the directive 2014/35/EU (LVD) and of EMC directive 2014/30/EU  
This instrument complies the directive 2011/65/EU (RoHS) and 2012/19/EU (WEEE) directive

**11.5. ACCESSORIES**

Use only the supplied and optional accessories included in the enclosed packing list

## 12. APPENDIX – THEORETICAL OUTLINE

### 12.1. VOLTAGE ANOMALIES

The instrument catalogs as voltage anomalies (sags, swells) all those RMS values, calculated every 10ms (@ 50Hz), which are out of the thresholds set upon configuration by  $\pm 1\%$  to  $\pm 30\%$  of a set reference value with a 1% step.

To prevent recording events attributable to electric noise only, a **hysteresis threshold of 1%** is also present. These limits remain unchanged throughout the whole recording period.

The reference voltage value must be set as:

- Rated voltage Phase-Neutral: for single-phase and three-phase 4-wire systems
- Rated voltage Phase-Earth: for three-phase 3-wire systems

**Example:** Three-phase 4-wire system.

$V_{ref} = 230V$ ,  $LIM(+)$  = 10%,  $LIM(-)$  = 10%, => Hysteresis 1%

Higher Lim =  $230 + 23 = 253V$ , Lower Lim =  $230 - 23 = 207V$

#### Recording swells

The instrument starts recording an event if voltage exceeds 253V and stops recording if voltage drops below  $253 - 2.53 = 250.5V$

#### Recording sags

The instrument starts recording an event if voltage is lower 207V and stops recording if voltage rises over  $207 + 2.07 = 209.1V$

For each event, the instrument records the following data:

- The number corresponding to the phase in which the anomaly occurred.
- The “direction” of the anomaly: “UP” and “DN” respectively identify voltage swell and sags
- The date and time in which the event starts in a format day, month, year, hour, minutes, seconds, hundredth of seconds.
- The duration of the event, in seconds with a resolution equal to 10ms.
- The minimum (or maximum) value of voltage during the event.

## 12.2. VOLTAGE AND CURRENT HARMONICS

Any periodic non-sinusoidal wave may be represented by a sum of sinusoidal waves, each with a frequency which is a whole multiple of the fundamental, according to the relationship:

$$v(t) = V_0 + \sum_{k=1}^{\infty} V_k \sin(\omega_k t + \varphi_k) \quad (1)$$

where:

$V_0$  = Average value of  $v(t)$

$V_1$  = Amplitude of the fundamental of  $v(t)$

$V_k$  = Amplitude of the k-nth harmonic of  $v(t)$

For network voltage, the fundamental has a frequency of 50 Hz, the second harmonic has a frequency of 100 Hz, the third harmonic has a frequency of 150 Hz and so on. Harmonic distortion is a continuous problem and must not be confused with short-duration phenomena such as peaks, drops or fluctuations. It can be seen how in (1) the index of the summation goes from 1 to infinity. What actually happens is that each signal has an unlimited number of harmonics: there is always a sequence number beyond which the value of the harmonics is negligible.

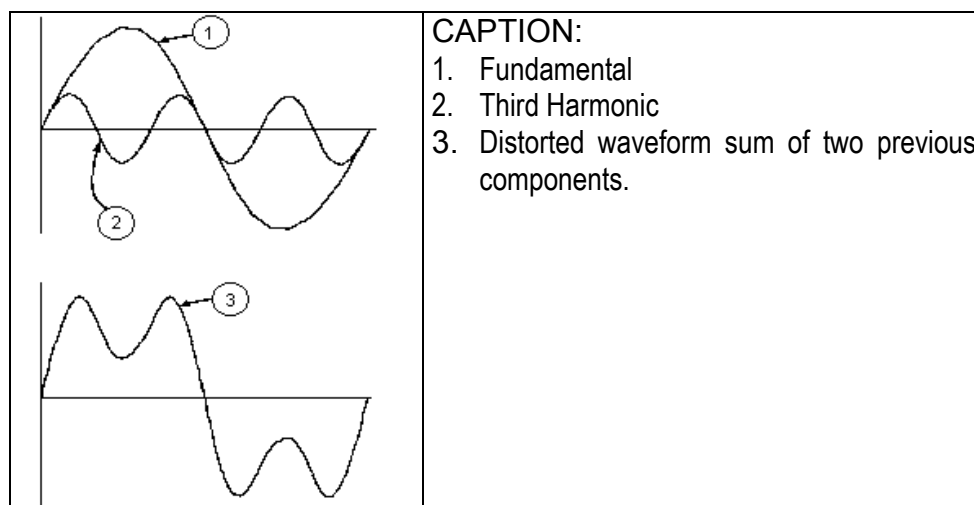

Effect of the sum of 2 multiple frequencies.

Standard EN 50160 suggests cutting the summation in the expression (1) at the 40<sup>th</sup> harmonic. A fundamental index to detect the presence of harmonics is the THD defined as:

$$THD_v = \frac{\sqrt{\sum_{h=2}^{40} V_h^2}}{V_1}$$

This index takes into consideration the presence of all harmonics, and the more distorted is the waveform, the higher is the index.

### 12.2.1. Limit values for harmonics

EN50160 guideline prescribes the limits for the Harmonic voltages the Supplier may put in network.

- In normal operating conditions, **at any time in a week**, 95% of the efficient values of each harmonic voltage, **averaged to 10 minutes**, must be lower than or equal to the values indicated in the following Table 6
- The total harmonic distortion (THD) of supply voltage (including all harmonics up to the 40th order) must be **lower than or equal to 8%**

Odd Harmonics				Even Harmonics	
Not multiple of 3		Multiple of 3		Order h	Relative Voltage %Max
Order h	Relative Voltage %Max	Order h	Relative Voltage %Max		
5	6	3	5	2	2
7	5	9	1.5	4	1
11	3.5	15	0.5	6..24	0.5
13	3	21	0.5		
17	2				
19	1.5				
23	1.5				
25	1.5				

Table 6: Maximum values of voltage harmonics in compliance with EN50160

These limits, which theoretically apply only to Electric Power Suppliers, anyway provide a series of reference values within which also the harmonics put into network by users should be kept.

### 12.2.2. Causes of the presence of harmonics

- Any appliance altering the sinusoidal wave or simply using a part of such wave causes distortions to the sinusoid, and hence harmonics
- All current signals are therefore somehow virtually distorted. The most common distortion is the harmonic distortion caused by non-linear loads such as household appliances, personal computers or motor speed adjusters. Harmonic distortion generates significant currents at frequencies which are whole multiples of network voltage. **Harmonic currents have a remarkable effect on neutral conductors** of electrical systems
- In most countries, the network voltage used is three-phase 50/60Hz, supplied by a transformer with triangle-connected primary circuit and star-connected secondary circuit. The secondary circuit generally generates 230V AC between phase and neutral and 400V AC between phase and phase. Balancing loads for each phase has always been a problem electrical system designers
- Until approximately ten years ago, in a fully balanced system, the vector sum of the currents in the neutral was zero or anyway quite low (given the difficulty of obtaining a perfect balance). Connected devices were incandescent lights, small motors and other devices that presented linear loads. The result was an essentially sinusoidal current in each phase and a low current on the neutral at a frequency of 50/60Hz. "Modern" devices such as TV sets, fluorescent lights, video machines and microwave ovens normally draw current for only a fraction of each cycle, thus causing non-linear loads and, consequently, non-linear currents

- All this generates odd harmonics of the 50/60Hz line frequency. For this reason, nowadays the current in the transformers of the distribution boxes contains not only a 50Hz (or 60Hz) component, but also a 150Hz (or 180Hz) component, a 250Hz (or 300Hz) component and other significant harmonic components up to 750Hz (or 900Hz) and above
- The vector sum of the currents in a fully balanced system that feeds non-linear loads may still be quite low. However, the sum does not eliminate all harmonic currents. **The odd multiples of the third harmonic (called “TRIPLENS”) are added together in the neutral** conductor and can cause overheating even with balanced loads.

### 12.2.3. Consequence of the presence of harmonics

- **Generally, harmonics of even order, 2<sup>nd</sup>, 4<sup>th</sup> etc. do not create problems.** Triple harmonics, odd multiple of three, sum on neutral (instead of nullifying themselves), thus generating a potentially dangerous overheating of the conductor
- Designers must consider the following three points when designing a power distribution system containing harmonic currents:
  1. The neutral conductor must have a sufficient size
  2. The distribution transformer must be equipped with an auxiliary cooling system in order to keep operating at its nominal capacity if it is not suitable for harmonics. This is necessary because the harmonic current on the neutral of the secondary circuit runs through the primary circuit which is triangle-connected. This circulating harmonic current leads to an overheating of the transformer
  3. The harmonic currents of phase are reflected onto the primary circuit and go back to the source. This may cause a voltage waves distortion so that any rephasing capacitor on the line may be easily overloaded.
- The 5<sup>th</sup> and 11<sup>th</sup> harmonic oppose to the flow of current through motors, thus making operation more difficult and reducing its average life
- Generally, the higher the harmonics order number is, the lower is its energy, and therefore its impact on appliances (except for transformers).

### 12.3. DEFINITIONS OF POWER AND POWER FACTOR

In a generic electrical system, powered by a sequence of sinusoidal voltages, the following is defined:

Phase Active Power:	(n=1,2,3)	$P_n = V_{nN} \cdot I_n \cdot \cos(\varphi_n)$
Phase Apparent Power:	(n=1,2,3)	$S_n = V_{nN} \cdot I_n$
Phase Reactive Power:	(n=1,2,3)	$Q_n = \sqrt{S_n^2 - P_n^2}$
Phase Power Factor:	(n=1,2,3)	$P_{Fn} = \frac{P_n}{S_n}$
Total Active Power:		$P_{TOT} = P_1 + P_2 + P_3$
Total Reactive Power:		$Q_{TOT} = Q_1 + Q_2 + Q_3$
Total Apparent Power:		$S_{TOT} = \sqrt{P_{TOT}^2 + Q_{TOT}^2}$
Total Power Factor:		$P_{FTOT} = \frac{P_{TOT}}{S_{TOT}}$

where:

$V_{nN}$  = Efficient value of voltage between phase n and neutral.

$I_n$  = Efficient value of the current of phase n.

$\varphi_n$  = Phase angle between voltage and current of phase n.

With distorted voltages and currents, the above-reported ratios change as follows:

Phase Active Power:	(n=1,2,3)	$P_n = \sum_{k=0}^{\infty} V_{kn} I_{kn} \cos(\varphi_{kn})$
Phase Apparent Power:	(n=1,2,3)	$S_n = V_{nN} \cdot I_n$
Phase Reactive Power:	(n=1,2,3)	$Q_n = \sqrt{S_n^2 - P_n^2}$
Phase Power Factor:	(n=1,2,3)	$P_{Fn} = \frac{P_n}{S_n}$
Deperate Power Factor:	(n=1,2,3)	dPF <sub>n</sub> =cosφ <sub>1n</sub> = phase angle between the voltage and current fundamentals of phase n.
Total Active Power:		$P_{TOT} = P_1 + P_2 + P_3$
Total Reactive Power:		$Q_{TOT} = Q_1 + Q_2 + Q_3$
Total Apparent Power:		$S_{TOT} = \sqrt{P_{TOT}^2 + Q_{TOT}^2}$
Total Power Factor:		$P_{FTOT} = \frac{P_{TOT}}{S_{TOT}}$

where:

$V_{kn}$  = Efficient value of the k-nth voltage harmonic between phase n and neutral.

$I_{kn}$  = Efficient value of the k-nth current harmonic of phase n.

$\varphi_{kn}$  = Phase angle between the k-nth voltage harmonic and the k-nth current harmonic of phase n

## NOTES

- Please note that, strictly speaking, the expression of phase reactive power in a non-sinusoidal condition would be incorrect. As to why, it may be useful to think that both the presence of harmonics and the presence of reactive power produce, among other effects, an increase in in-line power losses due to a higher efficient value of current
- With the above-indicated relationship, the increase rate in power losses due to the harmonics is algebraically summed to that introduced by the presence of reactive power. In fact, although the two phenomena contribute to causing an increase in in-line losses, it is not generally true that these power loss causes are in phase with each other and therefore algebraically summed
- The relationship above is justified by its relative simple calculation and by the relative difference between the value obtained with this relationship and the real value
- Also note that, in case of an electrical system with harmonics, a further parameter called deperated power factor (dPF) is determined. In fact, this parameter represents the theoretical limit value the power factor can reach if all harmonics are completely eliminated from the electrical system.

### 12.3.1. Conventions on powers and power factors

As regards recognizing the type of reactive power, the type of power factor and the sense of the active power, the conventions reported in the following scheme are adopted, where the angles indicated are the currents phase angles to voltage (e.g. in the first quadrant the current is  $0^\circ$  to  $90^\circ$  delayed compared to voltage):

<b>Capacitive generator</b>		<b>Q</b>		<b>Inductive load</b>	
		$90^\circ$	$0^\circ$		
<b>II Quadrant</b>				<b>I Quadrant</b>	
$P+$	= 0	$P-$	= P	$P+$	= P
$P_{fc+}$	= -1	$P_{fc-}$	= Pf	$P_{fc+}$	= +1
$P_{fi+}$	= -1	$P_{fi-}$	= +1	$P_{fi+}$	= Pf
$Q_{c+}$	= 0	$Q_{c-}$	= Q	$Q_{c+}$	= 0
$Q_{i+}$	= 0	$Q_{i-}$	= 0	$Q_{i+}$	= Q
$180^\circ$				$0^\circ$	
<b>III Quadrant</b>				<b>IV Quadrant</b>	
$P+$	= 0	$P-$	= P	$P+$	= P
$P_{fc+}$	= -1	$P_{fc-}$	= +1	$P_{fc+}$	= Pf
$P_{fi+}$	= -1	$P_{fi-}$	= Pf	$P_{fi+}$	= +1
$Q_{c+}$	= 0	$Q_{c-}$	= 0	$Q_{c+}$	= Q
$Q_{i+}$	= 0	$Q_{i-}$	= -Q	$Q_{i+}$	= 0
$270^\circ$				$0^\circ$	
<b>Inductive generator</b>				<b>Capacitive load</b>	
		<b>P</b>			

The meaning of the symbols used and of the values they take in the above-reported scheme is described in the following tables:

SYMBOL	MEANING	NOTES
P+	Value of active power +	Positive quantities (user user)
Pfc+	Capacitive power factor +	
Pfi+	Inductive power factor +	
Qc+	Value of capacitive reactive power +	
Qi+	Value of inductive reactive power +	
P-	Value of active power -	Negative quantities (generator user)
Pfc-	Capacitive power factor -	
Pfi-	Inductive power factor -	
Qc-	Value of capacitive reactive power -	
Qi-	Value of inductive reactive power -	

VALUE	MEANING
P	The relative (positive or negative) active power is defined in the quadrant examined, and therefore it takes the value of the active power in that moment.
Q	The relative (inductive or capacitive, positive or negative) reactive power is defined in the quadrant examined, and therefore it takes the value of the reactive power in that moment.
Pf	The relative (inductive or capacitive, positive or negative) power factor is defined in the quadrant examined, and therefore it takes the value of the power factor in that moment.
0	The relative (positive or negative) active power or the relative (inductive or capacitive, positive or negative) reactive power IS NOT defined in the quadrant examined, and therefore it takes a zero value.
-1	The relative (inductive or capacitive, positive or negative) power factor IS NOT defined in the quadrant examined.

## 12.4. INFORMATION ON THE MEASURING METHOD

The instrument is capable of measuring: voltages, currents, active powers, inductive and capacitive reactive powers, apparent powers, inductive and capacitive power factors and analogical or pulse parameters. All of these parameters are analyzed in a completely digital way: for each phase (voltage and current) 128 samples per period are taken, then repeating this operation for 18 consecutive periods.

### 12.4.1. Integration period

Saving all data would require a considerable memory capacity. Therefore, a saving method has been chosen that, although supplying significant data, would allow compression of the information to be saved.

After a time period called **Integration period**, which can be set upon configuration to a value between 5 seconds and 60 minutes, the instrument extracts the following values from the sampled values of each quantity to be saved:

- Minimum value of the quantity in the integration period (harmonics excluded)
- Average value of the quantity (intended as arithmetical mean of all values recorded in the integration period)
- Maximum value of the quantity in the integration period (harmonics excluded)

These three values only (repeated for each quantity to be saved) are saved in the memory together with the period start date and time.

Once these data are saved, the instrument starts acquiring data for a new period.

### 12.4.2. Calculation of the power factor

- According to the standards in force, the average power factor cannot be calculated as an average of the instantaneous power factors. It must be obtained from the average values of active and reactive power
- Each single average power factor, of phase or total, is therefore calculated, at the end of each integration period, on the average value of the corresponding powers, independently of the fact that they must be recorded or not
- Besides, for a better analysis of the type of load present on the line and in order to obtain reference terms in the invoicing analysis of the "low  $\cos\phi$ ", **the values of inductive and capacitive  $\cos\phi$  are treated as independent parameters**

## 13. SERVICE

### 13.1. WARRANTY CONDITIONS

This instrument is warranted against any material or manufacturing defect, in compliance with the general sales conditions. During the warranty period, defective parts may be replaced. However, the manufacturer reserves the right to repair or replace the product. Should the instrument be returned to the After-sales Service or to a Dealer, transport will be at the Customers charge. However, shipment will be agreed in advance. A report will always be enclosed to a shipment, stating the reasons for the products return. Only use original packaging for shipment; any damage due to the use of non-original packaging material will be charged to the Customer. The manufacturer declines any responsibility for injury to people or damage to property.

The warranty shall not apply in the following cases:

- Repair and/or replacement of accessories and battery (not covered by warranty).
- Repairs that may become necessary as a consequence of an incorrect use of the instrument or due to its use together with non-compatible appliances.
- Repairs that may become necessary as a consequence of improper packaging.
- Repairs which may become necessary as a consequence of interventions performed by unauthorized personnel.
- Modifications to the instrument performed without the manufacturers explicit authorization.
- Use not provided for in the instruments specifications or in the instruction manual.

The content of this manual cannot be reproduced in any form without the manufacturers authorization.

**Our products are patented and our trademarks are registered. The manufacturer reserves the right to make changes in the specifications and prices if this is due to improvements in technology.**

### 13.2. SERVICE

If the instrument does not operate properly, before contacting the After-sales Service, please check the conditions of cables and clamps and replace them, if necessary. Should the instrument still operate improperly, check that the product is operated according to the instructions given in this manual. Should the instrument be returned to the After-sales Service or to a Dealer, transport will be at the Customers charge. However, shipment will be agreed in advance. A report will always be enclosed to a shipment, stating the reasons for the products return. Only use original packaging for shipment; any damage due to the use of non-original packaging material will be charged to the Customer.



**HT INSTRUMENTS SA**

C/ Legalitat, 89  
08024 Barcelona - **ESP**  
Tel.: +34 93 408 17 77, Fax: +34 93 408 36 30  
eMail: info@htinstruments.com  
eMail: info@htinstruments.es  
Web: www.htinstruments.es

**HT INSTRUMENTS USA LLC**

3145 Bordentown Avenue W3  
08859 Parlin - NJ - **USA**  
Tel: +1 719 421 9323  
eMail: sales@ht-instruments.us  
Web: www.ht-instruments.com

**HT ITALIA SRL**

Via della Boaria, 40  
48018 Faenza (RA) - **ITA**  
Tel: +39 0546 621002  
Fax: +39 0546 621144  
eMail: ht@htitalia.it  
Web: www.ht-instruments.com

**HT INSTRUMENTS GMBH**

Am Waldfriedhof 1b  
D-41352 Korschenbroich - **GER**  
Tel: +49 (0) 2161 564 581  
Fax: + 49 (0) 2161 564 583  
eMail: info@ht-instruments.de  
Web: www.ht-instruments.de

**HT INSTRUMENTS BRASIL**

Rua Aguaçu, 171, bl. Ipê, sala 108  
13098321 Campinas SP - **BRA**  
Tel: +55 19 3367.8775  
Fax: +55 19 9979.11325  
eMail: vendas@ht-instruments.com.br  
Web: www.ht-instruments.com.br

**HT ITALIA CHINA OFFICE**

意大利HT中国办事处  
Room 3208, 490# Tianhe road, Guangzhou - **CHN**  
地址 : 广州市天河路490号壬丰大厦3208室  
Tel.: +86 400-882-1983, Fax: +86 (0) 20-38023992  
eMail: zenglx\_73@hotmail.com  
Web: www.guangzhouht.com