

---

# Keysight InfiniiVision HD3-Series Oscilloscopes

# Notices

© Keysight Technologies, Inc. 2005-2024

No part of this manual may be reproduced in any form or by any means (including electronic storage and retrieval or translation into a foreign language) without prior agreement and written consent from Keysight Technologies, Inc. as governed by United States and international copyright laws.

## Manual Part Number

54760-97004

## Edition

Second edition, September 2024

Available in electronic format only

Published by:

Keysight Technologies, Inc.  
1900 Garden of the Gods Road  
Colorado Springs, CO 80907 USA

## Print History

54760-97002, July 2024

54760-97004, September 2024

## Warranty

**The material contained in this document is provided "as is," and is subject to being changed, without notice, in future editions. Further, to the maximum extent permitted by applicable law, Keysight disclaims all warranties, either express or implied, with regard to this manual and any information contained herein, including but not limited to the implied warranties of merchantability and fitness for a particular purpose. Keysight shall not be liable for errors or for incidental or consequential damages in connection with the furnishing, use, or performance of this document or of any information contained herein. Should Keysight and the user have a separate written agreement with warranty terms covering the material in this document that conflict with these terms, the warranty terms in the separate agreement shall control.**

## Technology License

The hardware and/or software described in this document are furnished under a license and may be used or copied only in accordance with the terms of such license.

## U.S. Government Rights

The Software is "commercial computer software," as defined by Federal Acquisition Regulation ("FAR") 2.101. Pursuant to FAR 12.212 and 27.405-3 and Department of Defense FAR Supplement ("DFARS") 227.7202, the U.S. government acquires commercial computer software under the same terms by which the software is customarily provided to the public. Accordingly, Keysight provides the Software to U.S. government customers under its standard commercial license, which is embodied in its End User License Agreement (EULA), a copy of which can be found at [www.keysight.com/find/sweula](http://www.keysight.com/find/sweula). The license set forth in the EULA represents the exclusive authority by which the U.S. government may use, modify, distribute, or disclose the Software. The EULA and the license set forth therein, does not require or permit, among other things, that Keysight: (1) Furnish technical information related to commercial computer software or commercial computer software documentation that is not customarily provided to the public; or (2) Relinquish to, or otherwise provide, the government rights in excess of these rights customarily provided to the public to use, modify, reproduce, release, perform, display, or disclose commercial computer software or commercial computer software documentation. No additional government requirements beyond those set forth in the EULA shall apply, except to the extent that those terms, rights, or licenses are explicitly required from all providers of commercial computer software pursuant to the FAR and the DFARS and are set forth specifically in writing elsewhere in the EULA. Keysight shall be under no obligation to update, revise or otherwise modify the Software. With respect to any technical data as defined by FAR 2.101, pursuant to FAR 12.211 and 27.404.2 and DFARS 227.7102, the U.S. government acquires no greater

than Limited Rights as defined in FAR 27.401 or DFAR 227.7103-5 (c), as applicable in any technical data.

## Safety Notices

This product has been designed and tested in accordance with accepted industry standards, and has been supplied in a safe condition. The documentation contains information and warnings that must be followed by the user to ensure safe operation and to maintain the product in a safe condition.

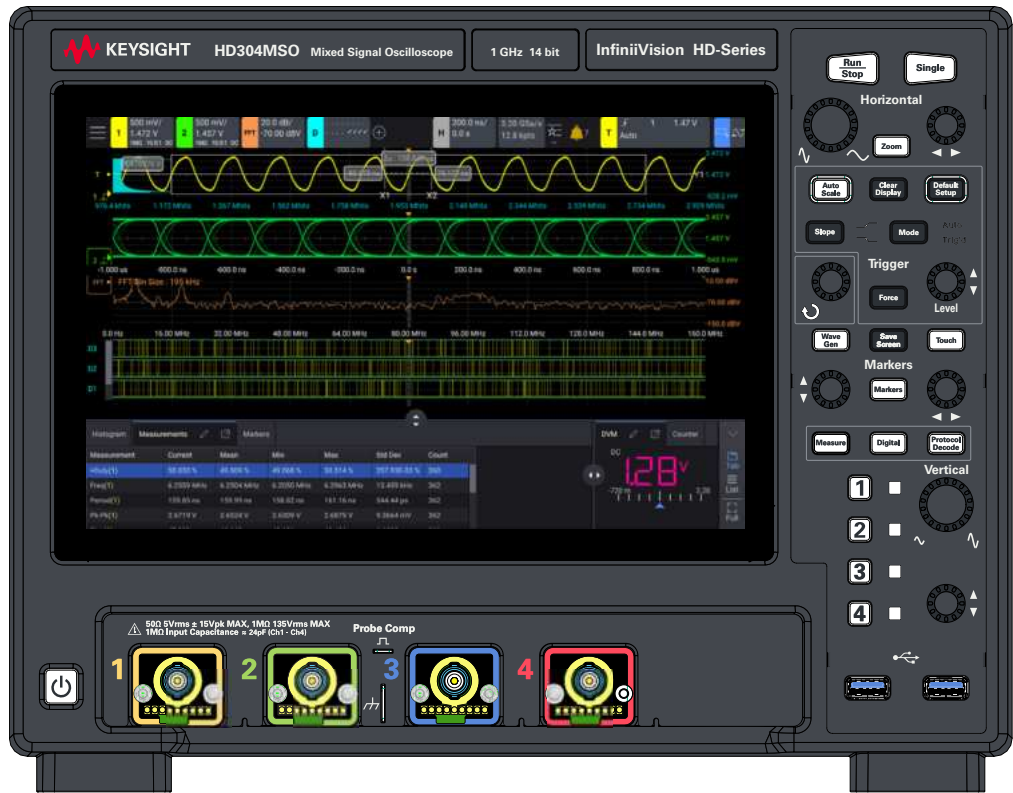
### CAUTION

A **CAUTION** notice denotes a hazard. It calls attention to an operating procedure, practice, or the like that, if not correctly performed or adhered to, could result in damage to the product or loss of important data. Do not proceed beyond a **CAUTION** notice until the indicated conditions are fully understood and met.

### WARNING

A **WARNING** notice denotes a hazard. It calls attention to an operating procedure, practice, or the like that, if not correctly performed or adhered to, could result in personal injury or death. Do not proceed beyond a **WARNING** notice until the indicated conditions are fully understood and met.

# InfiniiVision HD3-Series Oscilloscopes—At a Glance



**Table 1** HD3-Series Oscilloscope Model Numbers, Bandwidths, Sample Rates

	HD302MSO	HD304MSO
Bandwidth	200 MHz standard, options for 350 MHz, 500 MHz, and 1 GHz	
Sample Rate	3.2 GSa/s	3.2 GSa/s
Memory Depth	20 Mpts standard, options for 50 Mpts and 100 Mpts	
Analog Channels	2	4
Logic Channels MSO	16	16

The Keysight InfiniiVision HD3-Series oscilloscopes deliver these features:

- An MSO lets you debug your mixed-signal designs using analog signals and tightly correlated digital signals simultaneously. The sample rate for 8 digital channels (in D0-D7 or in D8-D15 only) is 1.6 GSa/s and the sample rate for all 16 digital channels is 800 MSa/s. The digital channels have a 100 MHz toggle rate.
- 10.1 inch WXGA touchscreen display (1280 x 800 pixels).

- Interleaved (full) or non-interleaved (half) MegaZoom IV memory for the fastest waveform update rates, uncompromised.
- Trigger types: edge, pulse width, pattern, OR, rise/fall time, runt, and setup & hold.
- Zone trigger.
- Protocol decode/trigger options for: CAN, I<sup>2</sup>C, LIN, SPI, and UART/RS232. Listing window for protocol decode.
- Math waveforms:
  - Arithmetic – add, subtract, multiply, and divide.
  - Transforms – absolute value, Ax+B, base 10 exponential, common logarithm, differentiate, exponential, integrate, natural logarithm, square root, and squared.
  - FFT – magnitude and phase.
  - Filters – band pass filter, low pass filter, high pass filter, averaged value, envelope, and smoothing.
  - Visualizations – magnify, max hold, maximum, measurement trend, min hold, minimum, and peak-peak.
- Reference waveforms (2) for comparing with other channel or math waveforms.
- Many built-in measurements and a measurement statistics display.
- Built-in license-enabled 100 MHz waveform generator with: arbitrary, sine, square, ramp, pulse, DC, noise, sine cardinal, exponential rise, exponential fall, cardiac, and gaussian pulse.
- USB and LAN ports make saving and sharing data easy.
- Online Help information is built into the oscilloscope.

For more information about InfiniiVision oscilloscopes, see:

[www.keysight.com/find/scope](http://www.keysight.com/find/scope)

## In This Guide

This guide shows how to use the InfiniiVision HD3-Series oscilloscopes.

When unpacking and using the oscilloscope for the first time, see:	<ul style="list-style-type: none"> <li>▪ <a href="#">Chapter 1</a>, “Getting Started,” starting on page 19</li> </ul>
When displaying waveforms and acquired data, see:	<ul style="list-style-type: none"> <li>▪ <a href="#">Chapter 2</a>, “Horizontal Controls,” starting on page 45</li> <li>▪ <a href="#">Chapter 3</a>, “Vertical Controls,” starting on page 55</li> <li>▪ <a href="#">Chapter 4</a>, “FFT Spectral Analysis,” starting on page 65</li> <li>▪ <a href="#">Chapter 5</a>, “Math Waveforms,” starting on page 75</li> <li>▪ <a href="#">Chapter 6</a>, “Reference Waveforms,” starting on page 99</li> <li>▪ <a href="#">Chapter 7</a>, “Digital Channels,” starting on page 103</li> <li>▪ <a href="#">Chapter 8</a>, “Protocol Decode,” starting on page 119</li> <li>▪ <a href="#">Chapter 9</a>, “Display Settings,” starting on page 123</li> </ul>
When setting up triggers or changing how data is acquired, see:	<ul style="list-style-type: none"> <li>▪ <a href="#">Chapter 10</a>, “Triggers,” starting on page 135</li> <li>▪ <a href="#">Chapter 11</a>, “Trigger Mode and Conditioning,” starting on page 153</li> <li>▪ <a href="#">Chapter 12</a>, “Acquisition Control,” starting on page 161</li> </ul>
Making measurements and analyzing data:	<ul style="list-style-type: none"> <li>▪ <a href="#">Chapter 13</a>, “Markers,” starting on page 177</li> <li>▪ <a href="#">Chapter 14</a>, “Measurements,” starting on page 185</li> <li>▪ <a href="#">Chapter 15</a>, “Histogram,” starting on page 213</li> <li>▪ <a href="#">Chapter 16</a>, “Mask Testing,” starting on page 221</li> <li>▪ <a href="#">Chapter 17</a>, “Digital Voltmeter and Counters,” starting on page 235</li> <li>▪ <a href="#">Chapter 18</a>, “Fault Hunter,” starting on page 239</li> <li>▪ <a href="#">Chapter 19</a>, “Frequency Response Analysis,” starting on page 245</li> </ul>
When using the built-in waveform generator, see:	<ul style="list-style-type: none"> <li>▪ <a href="#">Chapter 20</a>, “Waveform Generator,” starting on page 249</li> </ul>
When saving or recalling files, see:	<ul style="list-style-type: none"> <li>▪ <a href="#">Chapter 21</a>, “Save/Email/Recall (Setups, Screens, Data),” starting on page 261</li> </ul>
When using the oscilloscope's utility functions or web interface, see:	<ul style="list-style-type: none"> <li>▪ <a href="#">Chapter 22</a>, “Utility Settings,” starting on page 273</li> <li>▪ <a href="#">Chapter 23</a>, “Web Interface,” starting on page 293</li> </ul>

For reference information, see:	<ul style="list-style-type: none"> <li>▪ <b>Chapter 24</b>, “Reference,” starting on page 305</li> </ul>
When using licensed serial bus triggering and decode features, see:	<ul style="list-style-type: none"> <li>▪ <b>Chapter 25</b>, “CAN Triggering and Protocol Decode,” starting on page 319</li> <li>▪ <b>Chapter 26</b>, “I2C Triggering and Protocol Decode,” starting on page 331</li> <li>▪ <b>Chapter 27</b>, “LIN Triggering and Protocol Decode,” starting on page 339</li> <li>▪ <b>Chapter 28</b>, “SPI Triggering and Protocol Decode,” starting on page 347</li> <li>▪ <b>Chapter 29</b>, “UART/RS232/422/485 Triggering and Protocol Decode,” starting on page 355</li> </ul>

**TIP**

**Pressing keys, selecting user interface items, and choosing a series of menu items**

Instructions for pressing front panel keys include square brackets around the key name and bold typeface, for example: Press **[Key]**.

Instructions for selecting user interface items include bold typeface, for example: Select **Option Name** or **Button....**

Instructions for choosing a series of menu items are abbreviated. For example, instead of saying choose **Menu Item**, then choose **Sub Item**, then choose **Sub Sub Item**, those stages are abbreviated into: Choose **Menu Item > Sub Item > Sub Sub Item**.

# Contents

InfiniiVision HD3-Series Oscilloscopes—At a Glance / 3

In This Guide / 5

## 1 Getting Started

Inspect the Package Contents / 19

Learn the Front Panel Inputs and Outputs / 21

Learn the Back Panel Inputs and Outputs / 22

Tilt the Oscilloscope for Easy Viewing / 24

Power-On the Oscilloscope / 25

Select the User Interface Language / 26

Connect Probes to the Oscilloscope / 26



Maximum input voltage at analog inputs / 26



Do not float the oscilloscope chassis / 26

Input a Waveform / 27

Recall the Default Oscilloscope Setup / 27

Use Autoscale / 28

How Autoscale Works / 28

Compensate Passive Probes / 29

Learn the Front Panel Keys and Knobs / 30

Front Panel Overlays for Different Languages / 34

Using the Touchscreen User Interface	/ 35
Access Features From the Menu	/ 36
View and Change Settings With Badges	/ 36
Quick-Select Waveforms to Display	/ 37
Lay Out Waveform Grids	/ 37
View Waveforms in a Grid	/ 39
Drag Markers	/ 40
Customize the Favorites Menu	/ 40
View Logged Messages	/ 40
Select Draw Box or Drag Waveforms Mode	/ 40
View Results	/ 42
Enter Names Using Alpha-Numeric Keypad Dialogs	/ 42
Use a USB Mouse and/or Keyboard for Touchscreen Controls	/ 42
Access the Built-In Online Help	/ 43

## 2 Horizontal Controls

To adjust the horizontal scale (time/div)	/ 46
To adjust the horizontal delay (position)	/ 47
Panning and Zooming Single or Stopped Acquisitions	/ 48
To display the zoomed time base	/ 48
To change the horizontal scale coarse/fine adjustment setting	/ 50
To position the time reference (left, center, right, custom)	/ 50
Searching for Events	/ 51
To set up searches	/ 51
To copy search setups	/ 52
Navigating the Time Base	/ 52
To navigate time	/ 52
To navigate search events	/ 53
To navigate segments	/ 53

## 3 Vertical Controls

To turn waveforms on or off	/ 56
To adjust the vertical scale	/ 57
To adjust the vertical position	/ 57
To specify channel coupling	/ 57
To specify channel input impedance	/ 58
To specify bandwidth limiting	/ 59

To change the vertical scale knob's coarse/fine adjustment setting	/ 59
To invert a channel waveform	/ 60
Setting Analog Channel Probe Options	/ 60
To specify the channel units	/ 61
To specify the probe attenuation	/ 61
To specify the probe skew	/ 62
To calibrate a probe	/ 62
To specify the channel external scaling	/ 63

#### 4 FFT Spectral Analysis

Searching for FFT Peaks	/ 70
FFT Measurement Hints	/ 71
FFT Units	/ 72
FFT DC Value	/ 72
FFT Aliasing	/ 72
FFT Spectral Leakage	/ 73

#### 5 Math Waveforms


To display math waveforms	/ 75
Units for Math Waveforms	/ 78
Arithmetic Math Functions	/ 78
Add or Subtract	/ 79
Multiply or Divide	/ 79
Transforms Math Functions	/ 80
Absolute Value	/ 81
Ax + B	/ 81
Base 10 Exponential	/ 82
Common Logarithm	/ 83
Differentiate	/ 83
Exponential	/ 84
Integrate	/ 84
Natural Logarithm	/ 86
Square Root	/ 87
Square	/ 88
FFT Math Functions	/ 88
FFT Magnitude, FFT Phase	/ 88

Filters Math Functions /	90
Averaged Value /	90
Band Pass Filter /	91
Envelope /	91
High Pass and Low Pass Filter /	92
Smoothing /	92
Visualizations Math Functions /	93
Magnify /	93
Max/Min Hold /	94
Maximum/Minimum /	94
Measurement Trend /	94
The Analysis Record and Waveform Math /	95

## 6 Reference Waveforms

To save a waveform to a reference waveform location /	99
To display a reference waveform /	100
To scale and position reference waveforms /	100
To adjust reference waveform skew /	101
To display reference waveform summary information /	101
To save/recall reference waveform files to/from a USB storage device /	101

## 7 Digital Channels

To connect the digital probes to the device under test /	103
 Probe cable for digital channels /	104
Acquiring waveforms using the digital channels /	106
To display digital channels using Autoscale /	106
Interpreting the digital waveform display /	107
To change the displayed size of the digital channels /	108
To switch a single channel on or off /	109
To switch multiple digital channels on or off /	109
To reposition a digital channel /	109
To change the logic threshold for digital channels /	110
To display digital channels as a bus /	110

- Digital channel signal fidelity: Probe impedance and grounding / 113
  - Input Impedance / 113
  - Probe Grounding / 115
  - Best Probing Practices / 116

## 8 Protocol Decode

- Protocol Decode Options / 119
- Protocol Listing / 120
- Searching Lister Data / 121

## 9 Display Settings

- To change the waveform layout / 123
- To set or clear persistence / 124
- To clear the display / 126
- To select the grid options / 126
- To adjust the grid intensity / 127
- To display and edit waveform labels / 127
  - To turn the label display on or off / 128
  - To assign a predefined label to a waveform / 128
  - To define a new label / 128
  - To load a list of labels from a text file you create / 129
  - To reset the label library to the factory default / 130
- To add an annotation / 130
- To adjust waveform intensity / 132

## 10 Triggers

- Adjusting the Trigger Level / 136
- Forcing a Trigger / 137
- Edge Trigger / 137
- Pulse Width Trigger / 139
- Pattern Trigger / 141
  - Hex Bus Pattern Trigger / 143
- OR Trigger / 144
- Rise/Fall Time Trigger / 144
- Runt Trigger / 146

Setup and Hold Trigger / 147

Protocol Trigger / 149

Zone Qualified Trigger / 149

## 11 Trigger Mode and Conditioning

To select the Auto or Trig'd trigger mode / 154

To select the trigger coupling / 155

To enable or disable trigger noise rejection / 157

To enable or disable trigger HF Reject / 157

To disable or reenable trigger hysteresis / 158

To set the trigger holdoff / 158

External Trigger Input / 159



Maximum voltage at oscilloscope external trigger input / 160

## 12 Acquisition Control

Running, Stopping, and Making Single Acquisitions (Run Control) / 161

Overview of Sampling / 162

Sampling Theory / 162

Aliasing / 162

Oscilloscope Bandwidth and Sample Rate / 163

Oscilloscope Rise Time / 164

Oscilloscope Bandwidth Required / 165

Memory Depth and Sample Rate / 165

Selecting the Acquisition Mode / 166

Normal Acquisition Mode / 167

Peak Detect Acquisition Mode / 167

Averaging Acquisition Mode / 169

Selecting a Global Bandwidth Limit and Vertical Resolution / 171

Acquiring to Segmented Memory / 171

Navigating Segments / 173

Measurements, Statistics, and Infinite Persistence with Segmented Memory / 173

Segmented Memory Re-Arm Time / 173

Saving Data from Segmented Memory / 174

Digitizer Mode / 174

## 13 Markers

To make marker measurements / 178

Marker Examples / 181

## 14 Measurements

To quickly add 10 common measurements / 186

To make automatic measurements / 187

To edit measurements / 188

Measurements Summary / 188

Voltage Measurements / 190

Peak-Peak / 191

Maximum / 191

Minimum / 191

Y at X / 191

Amplitude / 191

Top / 191

Base / 192

Overshoot / 192

Preshoot / 193

Average / 194

DC RMS / 194

AC RMS / 195

Ratio / 196

Time Measurements / 196

Period / 197

Frequency / 197

Counter / 198

+ Width / 198

- Width / 199

Burst Width / 199

Duty Cycle / 199

Bit Rate / 199

Rise Time / 199

Fall Time / 200

Time at Edge / 200

Delay / 200

Phase / 201

X at Max Y / 202

X at Min Y / 203

Count Measurements /	203
Positive Pulse Count /	203
Negative Pulse Count /	203
Rising Edge Count /	204
Falling Edges Count /	204
Mixed Measurements /	204
Area /	204
Slew Rate /	205
FFT Analysis Measurements /	205
Channel Power /	205
Occupied Bandwidth /	205
Adjacent Channel Power Ratio (ACPR) /	206
Total Harmonic Distortion (THD) /	206
Measurement Thresholds /	207
Measurement Window /	209
Measurement Statistics /	209
Measurement Limit Testing /	211

## 15 Histogram

Waveform Histogram Set Up /	214
Defining the Histogram Limits Window /	216
Measurement Histogram Set Up /	217
Histogram Data Graph /	218
Histogram Data Statistics /	219

## 16 Mask Testing

To create a mask from a "golden" waveform (Automask) /	221
Mask Test Setup Options /	223
Mask Statistics /	225
To manually modify a mask file /	226
Building a Mask File /	229
Mask Region Limit Per Pixel Column /	232
How is mask testing done? /	232

## 17 Digital Voltmeter and Counters

Digital Voltmeter /	235
---------------------	-----

Counters / 237

## 18 Fault Hunter

More About Fault Hunter Auto Setup / 242

## 19 Frequency Response Analysis

To make connections / 245

To set up and run the analysis / 246

To view and save the analysis results / 247

## 20 Waveform Generator

To select generated waveform types and settings / 249

To specify the output settings / 253

To edit arbitrary waveforms / 254

To add modulation to the waveform generator output / 257

To set up Amplitude Modulation (AM) / 258

To set up Frequency Modulation (FM) / 259

## 21 Save/Email/Recall (Setups, Screens, Data)

Saving Setups, Screen Images, or Data / 261

To save setup files / 263

To save BMP or PNG image files / 263

To save CSV, ASCII XY, or BIN data files / 264

To save reference waveform files to a USB storage device / 266

To save masks / 266

To save arbitrary waveforms / 267

Emailing Setups, Screen Images, or Data / 267

Recalling Setups, Masks, or Data / 269

To recall setup files / 270

To recall mask files / 270

To recall reference waveform files from a USB storage device / 270

To recall arbitrary waveforms / 271

Recalling Default Setups / 271

Performing a Secure Erase / 272

## 22 Utility Settings

I/O Interface Settings / 273

Setting up the Oscilloscope's LAN Connection /	274
To establish a LAN connection /	275
Stand-alone (Point-to-Point) Connection to a PC /	276
File Explorer /	277
USB Storage Devices /	278
Setting Oscilloscope Preferences /	278
To choose "expand about" center or ground /	279
To disable/enable transparent backgrounds /	279
To set up the screen saver /	279
To set Autoscale preferences /	280
To scale the GUI larger or smaller /	281
Setting the Oscilloscope's Clock /	281
Setting the Rear Panel AUX OUT Source /	282
Enabling Remote Command Logging /	282
Setting Enhanced Security Options /	283
Performing Service Tasks /	287
To display the user calibration status /	287
To perform user calibration /	288
To perform hardware self test /	288
To perform front panel self test /	289
To display oscilloscope information /	290
To clean the oscilloscope /	290
To check warranty and extended services status /	290
To contact Keysight /	290
To return the instrument /	291
Configuring the (Quick Action) Menu Item /	291

## 23 Web Interface

Accessing the Web Interface /	294
Control Instrument /	295
Remote Programming via the Web Interface /	295
Remote Programming with Keysight IO Libraries /	296
Remote GUI Access Using VNC /	297
Get Image /	297
Save/Recall /	298
Saving Files via the Web Interface /	298
Recalling Files via the Web Interface /	299

Identification Function / 300

Instrument Utilities / 301

Setting a Password / 302

## 24 Reference

Specifications and Characteristics / 305

Measurement Category / 305

Oscilloscope Measurement Category / 305

Measurement Category Definitions / 306

Maximum Input Voltages / 306



Maximum input voltage at analog inputs / 306



Maximum input voltage at digital channels / 306

Environmental Conditions / 307

Probes and Accessories / 307

Loading Licenses and Displaying License Information / 308

Licensed Options Available / 308

Other Options Available / 308

Software and Firmware Updates / 308

Binary Data (.bin) Format / 309

Binary Data in MATLAB / 310

Binary Header Format / 310

Example Program for Reading Binary Data / 312

Examples of Binary Files / 312

CSV and ASCII XY files / 315

CSV and ASCII XY file structure / 315

Minimum and Maximum Values in CSV Files / 316

Frequency Data in CSV Files / 316

Acknowledgements / 316

Product Markings and Regulatory Information / 317

## 25 CAN Triggering and Protocol Decode

CAN/CAN FD Protocol Decode Setup / 319

Loading and Displaying CAN Symbolic Data / 323

CAN/CAN FD Triggering / 324

Interpreting CAN/CAN FD Decode / 326  
Interpreting CAN Lister Data / 328  
Searching for CAN Data in the Lister / 328

## 26 I2C Triggering and Protocol Decode

I2C Protocol Decode Setup / 331  
I2C Triggering / 333  
Interpreting I2C Decode / 336  
Interpreting I2C Lister Data / 337  
Searching for I2C Data in the Lister / 337

## 27 LIN Triggering and Protocol Decode

LIN Protocol Decode Setup / 339  
Loading and Displaying LIN Symbolic Data / 342  
LIN Triggering / 342  
Interpreting LIN Decode / 344  
Interpreting LIN Lister Data / 345  
Searching for LIN Data in the Lister / 345

## 28 SPI Triggering and Protocol Decode

SPI Protocol Setup / 347  
SPI Triggering / 350  
Interpreting SPI Decode / 351  
Interpreting SPI Lister Data / 352  
Searching for SPI Data in the Lister / 352

## 29 UART/RS232/422/485 Triggering and Protocol Decode

UART/RS232/422/485 Protocol Decode Setup / 355  
UART/RS232/422/485 Triggering / 358  
Interpreting UART/RS232/422/485 Decode / 360  
Interpreting UART/RS232/422/485 Lister Data / 361  
Searching for UART/RS232/422/485 Data in the Lister / 361

## Index

# 1 Getting Started

Inspect the Package Contents /	19
Learn the Front Panel Inputs and Outputs /	21
Learn the Back Panel Inputs and Outputs /	22
Tilt the Oscilloscope for Easy Viewing /	24
Power-On the Oscilloscope /	25
Select the User Interface Language /	26
Connect Probes to the Oscilloscope /	26
Input a Waveform /	27
Recall the Default Oscilloscope Setup /	27
Use Autoscale /	28
Compensate Passive Probes /	29
Learn the Front Panel Keys and Knobs /	30
Using the Touchscreen User Interface /	35

This chapter describes the steps you take when using the oscilloscope for the first time.

## Inspect the Package Contents

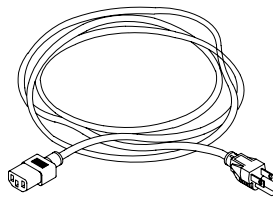
- Inspect the shipping container for damage.  
If your shipping container appears to be damaged, keep the shipping container or cushioning material until you have inspected the contents of the shipment for completeness and have checked the oscilloscope mechanically and electrically.
- Verify that you received the following items and any optional accessories you may have ordered:
  - InfiniiVision HD3-Series oscilloscope.
  - Power cord (country of origin determines specific type).
  - Oscilloscope probes:

# 1 Getting Started

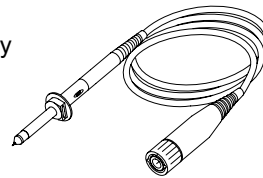
- Two probes for 2-channel models.
- Four probes for 4-channel models.



InfiniiVision HD3-Series oscilloscope



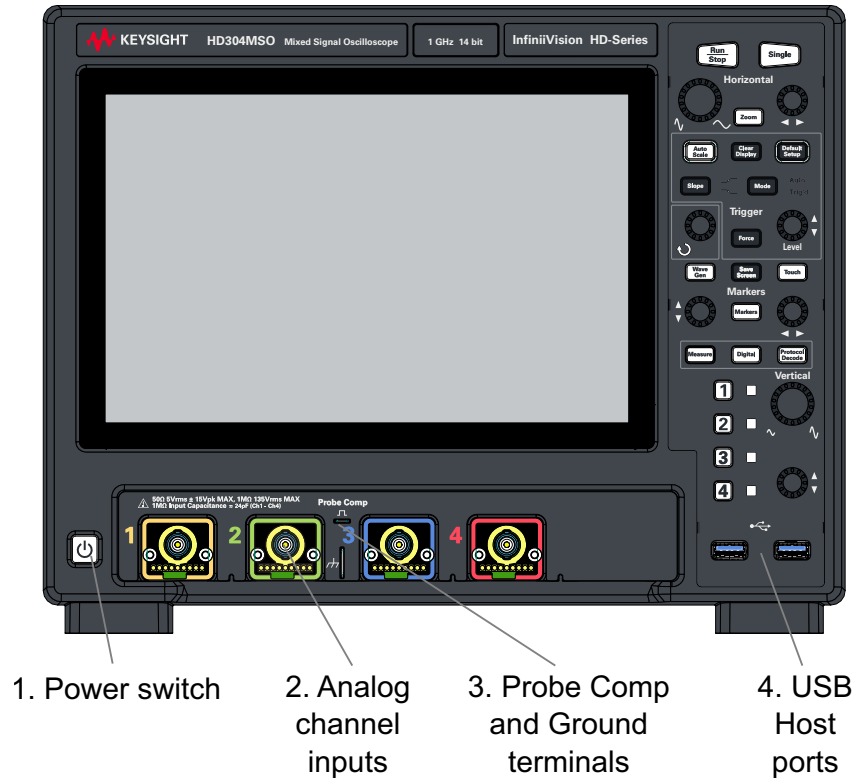
Power cord  
(Based on country  
of origin)



N2843A probes  
(Qty 2 or 4)

See Also • ["Probes and Accessories"](#) on page 307

## Learn the Front Panel Inputs and Outputs

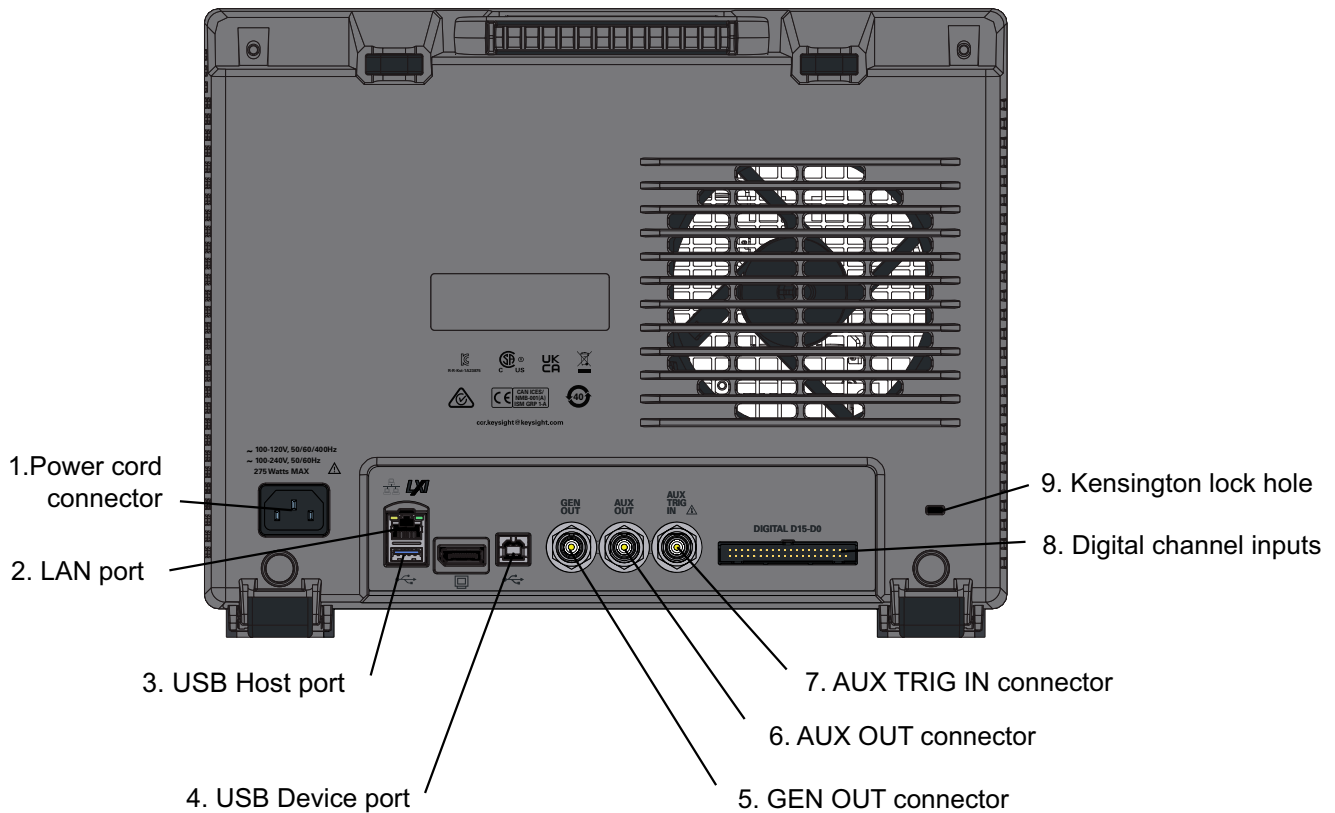


1.	Power switch	<p>Press once to switch power on; press again to switch power off.</p> <p>The front panel switch is a standby switch only and is not a LINE switch. The detachable power cord is the instrument disconnecting device. It disconnects the mains circuits from the mains supply before other parts of the instrument. Therefore, install the instrument so that the detachable power cord is readily identifiable and is easily reached by the operator.</p> <p>See <b>"Power-On the Oscilloscope"</b> on page 25.</p>
2.	Analog channel inputs	<p>Attach oscilloscope probes or BNC cables to these BNC connectors.</p> <p>With the InfiniiVision HD3-Series oscilloscopes, you can set the input impedance of the analog channels to either 50 <math>\Omega</math> or 1 M<math>\Omega</math>. See <b>"To specify channel input impedance"</b> on page 58.</p> <p>The InfiniiVision HD3-Series oscilloscopes also provide the AutoProbe interface. The AutoProbe interface uses a series of contacts directly below the channel's BNC connector to transfer information between the oscilloscope and the probe. When you connect a compatible probe to the oscilloscope, the AutoProbe interface determines the type of probe and sets the oscilloscope's parameters (units, offset, attenuation, coupling, and impedance) accordingly.</p>

3.	Probe Comp and Ground terminals	<ul style="list-style-type: none"> <li>▪ Probe Comp terminal – After a <b>[Default Setup]</b>, this terminal outputs the Probe Comp signal which helps you match a probe's input capacitance to the oscilloscope channel to which it is connected. See <b>"Compensate Passive Probes"</b> on page 29. The oscilloscope can also output demo or training signals on this terminal.</li> <li>▪ Ground terminal – Use the ground terminal for oscilloscope probes connected to the Probe Comp terminal.</li> </ul>
4.	USB Host ports	<p>These ports are for connecting a USB mass storage device, mouse, or keyboard to the oscilloscope.</p> <p>Connect a USB compliant mass storage device (flash drive, disk drive, etc.) to save or recall oscilloscope setup files and reference waveforms or to save data and screen images. See <b>Chapter 21</b>, "Save/Email/Recall (Setups, Screens, Data)," starting on page 261.</p> <p>You can also use the USB port to update the oscilloscope's system software when updates are available.</p> <p>You do not need to take special precautions before removing the USB mass storage device from the oscilloscope (you do not need to "eject" it). Simply unplug the USB mass storage device from the oscilloscope when the file operation is complete.</p> <p>There is a third USB host port on the back panel.</p>

## Learn the Back Panel Inputs and Outputs

For the following figure, refer to the numbered descriptions in the table that follows.

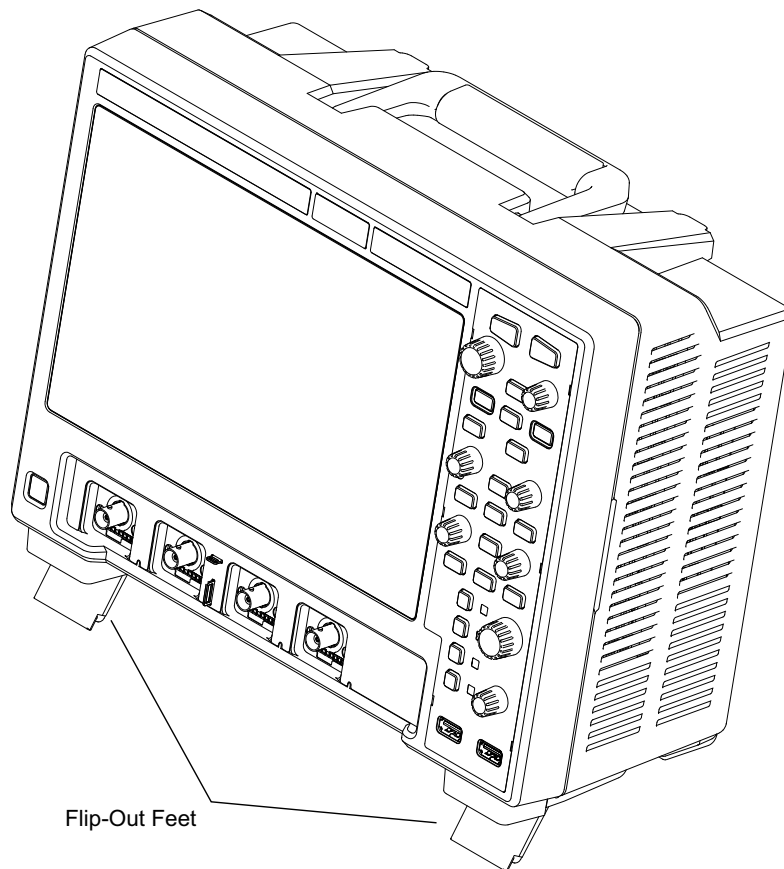


1.	Power cord connector	Attach the power cord here.
2.	LAN port	Lets you place the oscilloscope on the network for access the built-in web server and remote programming. See <a href="#">Chapter 23, "Web Interface,"</a> starting on page 293 and <a href="#">"Remote Programming with Keysight IO Libraries"</a> on page 296.
3.	USB Host port	This port functions identically to the USB host ports on the front panel. USB Host Port is used for saving data from the oscilloscope and loading software updates.
4.	USB Device port	This port is for connecting the oscilloscope to a host PC. You can issue remote commands from a host PC to the oscilloscope via the USB device port. See <a href="#">"Remote Programming with Keysight IO Libraries"</a> on page 296.
5.	GEN OUT connector	Built-in, license-enabled waveform generator can output arbitrary, sine, square, ramp, pulse, DC, noise, sine cardinal, exponential rise, exponential fall, cardiac, or Gaussian pulse waveforms on the GEN OUT BNC connector. Modulated waveforms are available except for arbitrary, pulse, DC, and noise waveforms. Press the <b>[Wave Gen]</b> key to set up the waveform generator. See <a href="#">Chapter 20, "Waveform Generator,"</a> starting on page 249.

6.	AUX OUT connector	Auxiliary output BNC connector. See <b>"Setting the Rear Panel AUX OUT Source"</b> on page 282.
7.	AUX TRIG IN connector	Auxiliary trigger input BNC connector. See <b>"External Trigger Input"</b> on page 159 for an explanation of this feature.
8.	Digital channel inputs	Connect the digital probe cable to this connector. See <b>Chapter 7</b> , "Digital Channels," starting on page 103.
9.	Kensington lock hole	This is where you can attach a Kensington lock for securing the instrument.

## Tilt the Oscilloscope for Easy Viewing

There are tabs under the oscilloscope's front feet that can be flipped out to tilt the oscilloscope.



## Power-On the Oscilloscope

### Power Requirements

Line voltage, frequency, and power:

- ~ 100-120 Vac, 50/60/400 Hz
- ~ 100-240 Vac, 50/60 Hz
- 275 Watts MAX

Mains supply voltage fluctuations are not to exceed  $\pm 10\%$  of the nominal supply voltage.

### Ventilation Requirements

The air intake and exhaust areas must be free from obstructions. Unrestricted air flow is required for proper cooling. Always ensure that the air intake and exhaust areas are free from obstructions.

The fan draws air in from the left side and bottom of the oscilloscope and pushes it out behind the oscilloscope.

When using the oscilloscope in a bench-top setting, provide at least 2" clearance at the sides and 4" (100 mm) clearance above and behind the oscilloscope for proper cooling.

### To power-on the oscilloscope

- 1 Connect the power cord to the rear of the oscilloscope, then to a suitable AC voltage source. Route the power cord so the oscilloscope's feet and legs do not pinch the cord.

Install the instrument so that the detachable power cord is readily identifiable and is easily reached by the operator. The detachable power cord is the instrument disconnecting device. It disconnects the mains circuits from the mains supply before other parts of the instrument. The front panel switch is only a standby switch and is not a LINE switch. Alternatively, an externally installed switch or circuit breaker (which is readily identifiable and is easily reached by the operator) may be used as a disconnecting device.

- 2 The oscilloscope automatically adjusts for input line voltages in the range 100 to 240 VAC. The line cord provided is matched to the country of origin.

### WARNING

**Always use a grounded power cord. Do not defeat the power cord ground.**

- 3 Press the power switch.

The power switch is located on the lower left corner of the front panel. The oscilloscope will perform a self-test and will be operational in a minute or so.

### To power cycle the oscilloscope

From the menu, choose **File > Power Cycle**. This is the same as pressing the front panel power button to power down the oscilloscope and then pressing the power button again to start the oscilloscope.

**To shut down the oscilloscope** From the menu, choose **File > Shut Down**. This is the same as pressing the front panel power button to power down the oscilloscope. This allows the oscilloscope to shut down gracefully.

## Select the User Interface Language

To select the user interface language:

- 1 From the menu, choose **Help > Language...**
- 2 In the Language dialog box, select your preferred user interface **Language**.

The following languages are available: English, French, German, Italian, Japanese, Korean, Portuguese, Simplified Chinese, Spanish, Thai, and Traditional Chinese.

## Connect Probes to the Oscilloscope

- 1 Connect the oscilloscope probe to an oscilloscope channel BNC connector.
- 2 Connect the probe's retractable hook tip to the point of interest on the circuit or device under test. Be sure to connect the probe ground lead to a ground point on the circuit.

### CAUTION

#### **Maximum input voltage at analog inputs**

135 Vrms

50Ω input: 5 Vrms Input protection is enabled in 50 Ω mode and the 50 Ω load will disconnect if greater than 5 Vrms is detected. However the inputs could still be damaged, depending on the time constant of the signal. The 50 Ω input protection only functions when the oscilloscope is powered on.

### CAUTION

When measuring voltages over 80 V, use a 10:1 probe.

### CAUTION

#### **Do not float the oscilloscope chassis**

Defeating the ground connection and "floating" the oscilloscope chassis will probably result in inaccurate measurements and may also cause equipment damage. The probe ground lead is connected to the oscilloscope chassis and the ground wire in the power cord. If you need to measure between two live points, use a differential probe with sufficient dynamic range.

**WARNING**

**Do not negate the protective action of the ground connection to the oscilloscope. The oscilloscope must remain grounded through its power cord. Defeating the ground creates an electric shock hazard.**

## Input a Waveform

The first signal to input to the oscilloscope is the Probe Comp signal. This signal is used for compensating probes.

- 1 Connect an oscilloscope probe from channel 1 to the **Probe Comp** terminal on the front panel.
- 2 Connect the probe's ground lead to the ground terminal (below the **Probe Comp** terminal).

## Recall the Default Oscilloscope Setup

To recall the default oscilloscope setup:

- 1 Press **[Default Setup]**.

The default setup restores the oscilloscope's default settings. This places the oscilloscope in a known operating condition. The major default settings are:

Horizontal	Normal mode, 100 $\mu$ s/div scale, 0 s delay, center time reference.
Vertical (Analog)	Channel 1 on, 5 V/div scale, DC coupling, 0 V position, 1 M $\Omega$ impedance.
Trigger	Edge trigger, Auto trigger mode, 0 V level, channel 1 source, DC coupling, rising edge slope, 40 ns holdoff time.
Display	Persistence off, 20% grid intensity, 50% waveform intensity.
Other	Acquire mode normal, <b>[Run/Stop]</b> to Run, markers and measurements off.
Labels	All custom labels that you have created in the Label Library are preserved (not erased), but all channel labels will be set to their original names.

In the Default dialog box (from the menu, choose **Control > Default...**), there are also options for restoring the complete factory settings (see "**Recalling Default Setups**" on page 271) or performing a secure erase (see "**Performing a Secure Erase**" on page 272).

## Use Autoscale

Use **[Auto Scale]** to automatically configure the oscilloscope to best display the input signals.

- 1 Press **[Auto Scale]**.

You should see a waveform on the oscilloscope's display similar to this:



- 2 If you want to return to the oscilloscope settings that existed before, select the



Undo button.

- 3 If you want to enable "fast debug" autoscaling, change the channels autoscaled, or preserve the acquisition mode during autoscale, use the Autoscale dialog box (from the menu, choose **Utilities > User Options...**, then select **Autocale...**). See **"To set Autoscale preferences"** on page 280.

If you see the waveform, but the square wave is not shaped correctly as shown above, perform the procedure **"Compensate Passive Probes"** on page 29.

If you do not see the waveform, make sure the probe is connected securely to the front panel channel input BNC and to the Probe Comp terminal.

## How Autoscale Works

Autoscale analyzes any waveforms present at each channel and at the external trigger input. This includes the digital channels, if connected.

Autoscale finds, turns on, and scales any channel with a repetitive waveform that has a frequency of at least 25 Hz, a duty cycle greater than 0.5%, and an amplitude of at least 10 mV peak-to-peak. Any channels where no signal is found are turned off.

The trigger source is selected by looking for the first valid waveform starting with external trigger, then continuing with the lowest number analog channel up to the highest number analog channel, and finally (if digital probes are connected) the highest number digital channel.

During Autoscale, the delay is set to 0.0 seconds, the horizontal time/div (sweep speed) setting is a function of the input signal (about 2 periods of the triggered signal on the screen), and the triggering mode is set to Edge.

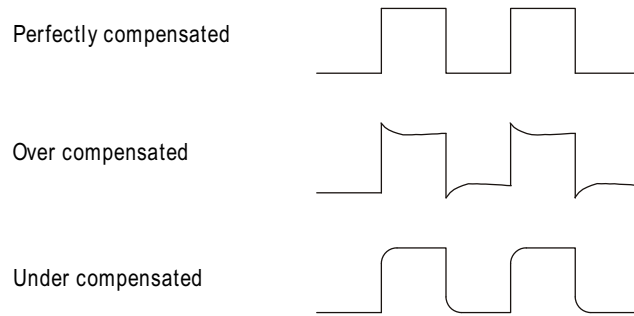
## Compensate Passive Probes

Each oscilloscope passive probe must be compensated to match the input characteristics of the oscilloscope channel to which it is connected. A poorly compensated probe can introduce significant measurement errors.

- 1 Input the Probe Comp signal (see **"Input a Waveform"** on page 27).
- 2 Press **[Default Setup]** to recall the default oscilloscope setup (see **"Recall the Default Oscilloscope Setup"** on page 27).
- 3 Press **[Auto Scale]** to automatically configure the oscilloscope for the Probe Comp signal (see **"Use Autoscale"** on page 28).
- 4 Open the Channel dialog box (from the menu, choose **Sources > Channel N...**) where N is the channel to which the probe is connected (**1, 2**, etc.).
- 5 Select **Probe...**
- 6 In the Probe dialog box, select **Probe Check**; then, follow the instructions on-screen.

If necessary, use a nonmetallic tool (supplied with the probe) to adjust the trimmer capacitor on the probe for the flattest pulse possible.

On N2894A probes, the trimmer capacitor is located on the probe BNC connector.

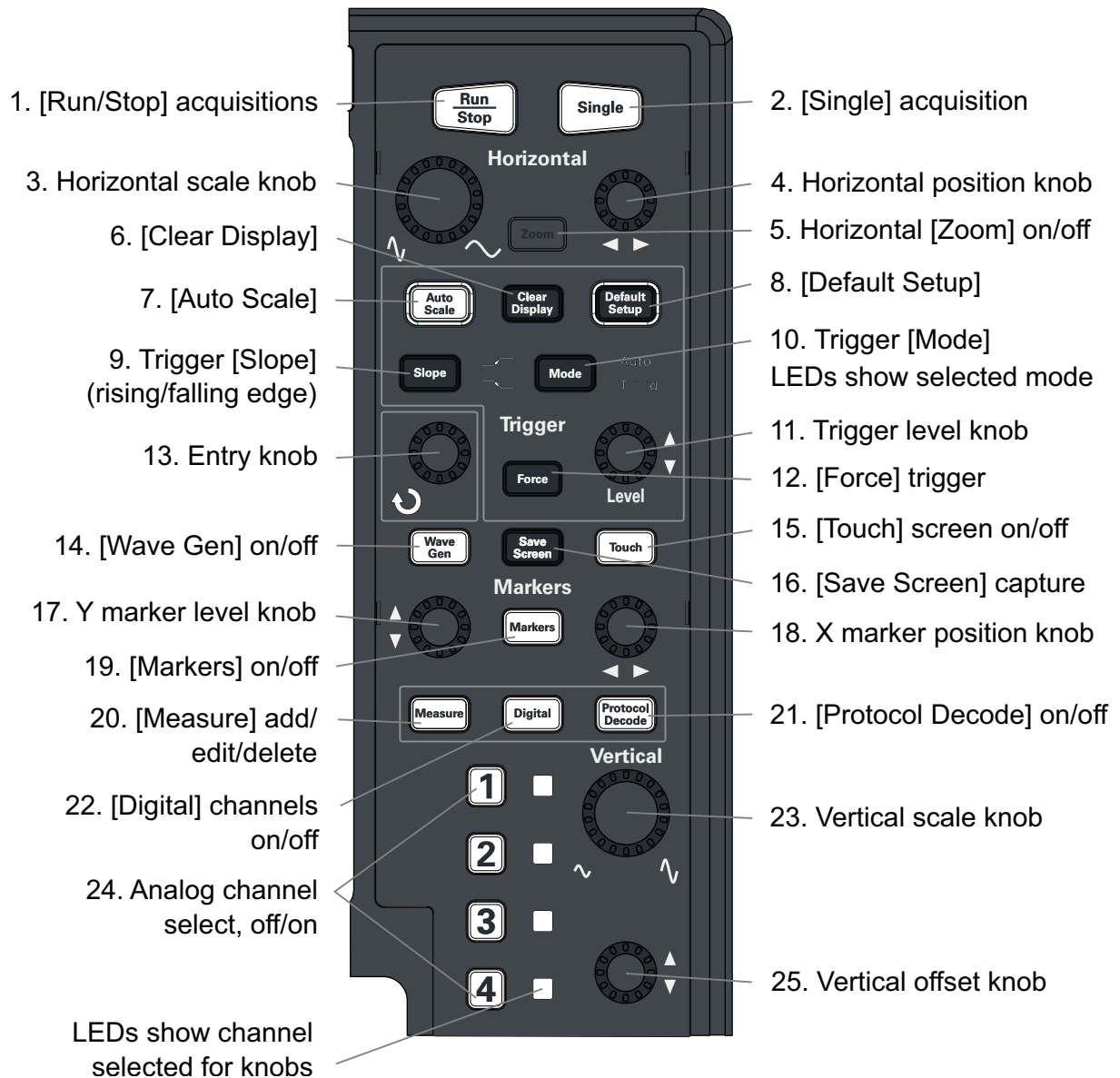


- 7** Connect probes to all other oscilloscope channels (channel 2 of a 2-channel oscilloscope, or channels 2, 3, and 4 of a 4-channel oscilloscope).
- 8** Repeat the procedure for each channel.




## Learn the Front Panel Keys and Knobs


On the front panel, *key* refers to any key (button) you can press.

For the following figure, refer to the numbered descriptions in the table that follows.



1.	<b>[Run/Stop]</b> key	<p>When the <b>[Run/Stop]</b> key is green, the oscilloscope is running, that is, acquiring data when trigger conditions are met. To stop acquiring data, press <b>[Run/Stop]</b>.</p> <p>When the <b>[Run/Stop]</b> key is red, data acquisition is stopped. To start acquiring data, press <b>[Run/Stop]</b>.</p> <p>See "<a href="#">Running, Stopping, and Making Single Acquisitions (Run Control)</a>" on page 161.</p>
2.	<b>[Single]</b> key	<p>To capture and display a single acquisition (whether the oscilloscope is running or stopped), press <b>[Single]</b>. The <b>[Single]</b> key is yellow until the oscilloscope triggers.</p> <p>See "<a href="#">Running, Stopping, and Making Single Acquisitions (Run Control)</a>" on page 161.</p>

3.	Horizontal scale knob	<p>Turn the knob in the Horizontal section that is marked  to adjust the time/div (sweep speed) setting. The symbols under the knob indicate that this control has the effect of spreading out or zooming in on the waveform using the horizontal scale. See <a href="#">Chapter 2</a>, "Horizontal Controls," starting on page 45.</p>
4.	Horizontal position knob	<p>Turn the knob marked ◀▶ to pan through the waveform data horizontally. You can see the captured waveform before the trigger (turn the knob clockwise) or after the trigger (turn the knob counterclockwise). If you pan through the waveform when the oscilloscope is stopped (not in Run mode) then you are looking at the waveform data from the last acquisition taken. See <a href="#">Chapter 2</a>, "Horizontal Controls," starting on page 45.</p>
5.	[Zoom] key	<p>Press the [Zoom] key to split the oscilloscope display into Normal and Zoom sections without opening the Horizontal Menu. See <a href="#">Chapter 2</a>, "Horizontal Controls," starting on page 45.</p>
6.	[Clear Display] key	<p>When you press the [Clear Display] key, acquisition data is cleared from the oscilloscope display. See <a href="#">"To clear the display"</a> on page 126.</p>
7.	[Auto Scale] key	<p>When you press the [Auto Scale] key, the oscilloscope will quickly determine which channels have activity, and it will turn these channels on and scale them to display the input signals. See <a href="#">"Use Autoscale"</a> on page 28.</p>
8.	[Default Setup] key	<p>Press this key to restore the oscilloscope's default settings (details on <a href="#">"Recall the Default Oscilloscope Setup"</a> on page 27).</p>
9.	[Slope] key	<p>Press until the desired slope LED is lit. You can have an edge trigger on a rising or falling edge. See <a href="#">Chapter 10</a>, "Triggers," starting on page 135.</p>
10.	[Mode] key	<p>Press until the desired LED is lit (<b>Trig'd</b> or <b>Auto</b>).</p> <p>When <b>Trig'd</b> is selected, the oscilloscope must find the trigger before saving and displaying captured data.</p> <p>When <b>Auto</b> is selected, if a trigger does not occur within a certain amount of time, an acquisition is automatically saved and displayed. In <b>Auto</b> trigger mode, you are able to see your signals while setting up the desired trigger.</p> <p>See <a href="#">Chapter 10</a>, "Triggers," starting on page 135.</p>
11.	Trigger Level knob	<p>Turn the knob adjust the vertical level used for analog channel edge detection. See <a href="#">Chapter 10</a>, "Triggers," starting on page 135.</p>
12.	[Force] key	<p>Press to trigger on anything and make a single acquisition.</p> <p>This is sometimes useful in the <b>Trig'd</b> mode to view a signal when triggers are not occurring. See <a href="#">Chapter 10</a>, "Triggers," starting on page 135.</p>
13.	Entry knob	<p>The Entry knob is used to select items from menus and to change values. The function of the Entry knob changes based upon the current menu and entry field selections.</p> <p>Note that the curved arrow symbol  next to the entry knob illuminates whenever the entry knob can be used to select a value. Also, note that when the Entry knob  symbol appears in an entry field, you can use the Entry knob, to select values.</p> <p>Often, rotating the Entry knob is enough to make a selection. Sometimes, you can push the Entry knob to enable or disable a selection. Pushing the Entry knob also makes popup menus disappear.</p>

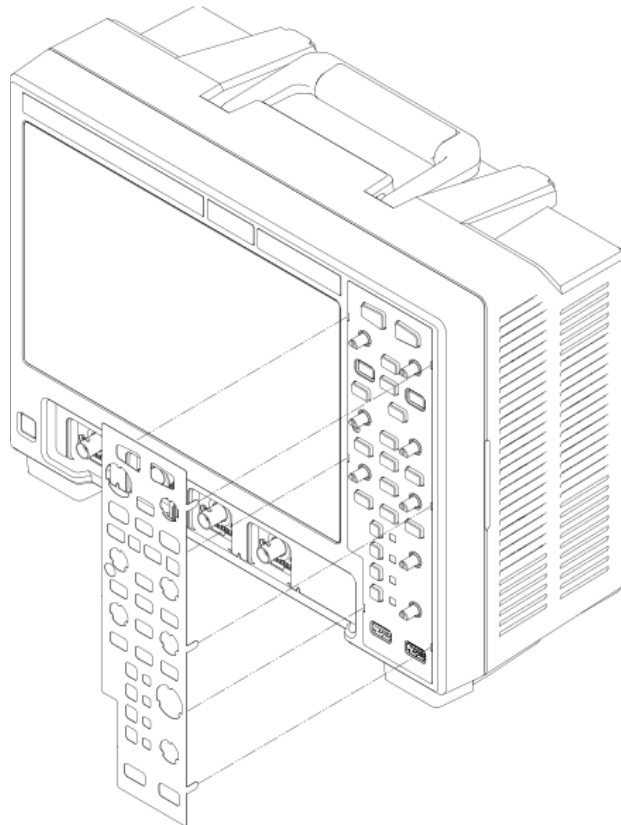
14.	<b>[Wave Gen]</b> key	Press this key to access waveform generator functions. See <a href="#">Chapter 20</a> , "Waveform Generator," starting on page 249.
15.	<b>[Touch]</b> key	Press this key to disable/enable the touchscreen.
16.	<b>[Save Screen]</b> key	Press to capture and save a screen image to a file. A message about the saved file is displayed and logged. See <a href="#">"Using the Touchscreen User Interface"</a> on page 35. The location and file name are derived from the last values specified in the Save dialog box. See <a href="#">"To save BMP or PNG image files"</a> on page 263.
17.	Y marker level knob	When markers are turned on, push this knob to cycle through Y marker selection. Selected marker(s) are highlighted. Then, rotate the knob to adjust the selected marker(s) level. See <a href="#">Chapter 13</a> , "Markers," starting on page 177.
18.	X marker position knob	When markers are turned on, push this knob to cycle through X marker selection. Selected marker(s) are highlighted. Then, rotate the knob to adjust the selected marker(s) position. See <a href="#">Chapter 13</a> , "Markers," starting on page 177.
19.	<b>[Markers]</b> key	Press this key to turn markers on or off. In the Markers results window, you can select the edit (pencil) icon to open the Markers dialog box where you can select the markers mode source. See <a href="#">Chapter 13</a> , "Markers," starting on page 177.
20.	<b>[Digital]</b> key	Press this key to turn the digital channels on or off. If a trace is repositioned over an existing trace the indicator at the left edge of the trace will change from <b>Dnn</b> designation (where nn is a one or two digit channel number from 0 to 15) to <b>D*</b> . The "*" indicates that two or more channels are overlaid. You can rotate the upper knob to select an overlaid channel, then rotate the lower knob to position it just as you would any other channel. For more information on digital channels see <a href="#">Chapter 7</a> , "Digital Channels," starting on page 103.
21.	<b>[Protocol Decode]</b> key	This key is used to enable protocol decode. See <a href="#">Chapter 8</a> , "Protocol Decode," starting on page 119.
22.	Analog channel on/off keys	Use these keys to switch a channel on or off. There is one channel on/off key for each analog channel. LEDs next to the channels keys show the channel selected for the vertical scale and position knob adjustment. See <a href="#">Chapter 3</a> , "Vertical Controls," starting on page 55.
23.	Vertical scale knob	This knob is marked  . Use this knob to change the vertical sensitivity (gain) of the selected analog channel. See <a href="#">Chapter 3</a> , "Vertical Controls," starting on page 55.
24.	Vertical position knob	Use this knob to change the selected channel's vertical position on the display. See <a href="#">Chapter 3</a> , "Vertical Controls," starting on page 55.

## Front Panel Overlays for Different Languages

Front panel overlays, which have translations for the English front panel keys and label text, are available in several languages. The appropriate overlay is included when the localization option is chosen at time of purchase.

To install a front panel overlay:

- 1 Gently pull on the front panel knobs to remove them.
- 2 Insert the overlay's side tabs into the slots on the front panel.



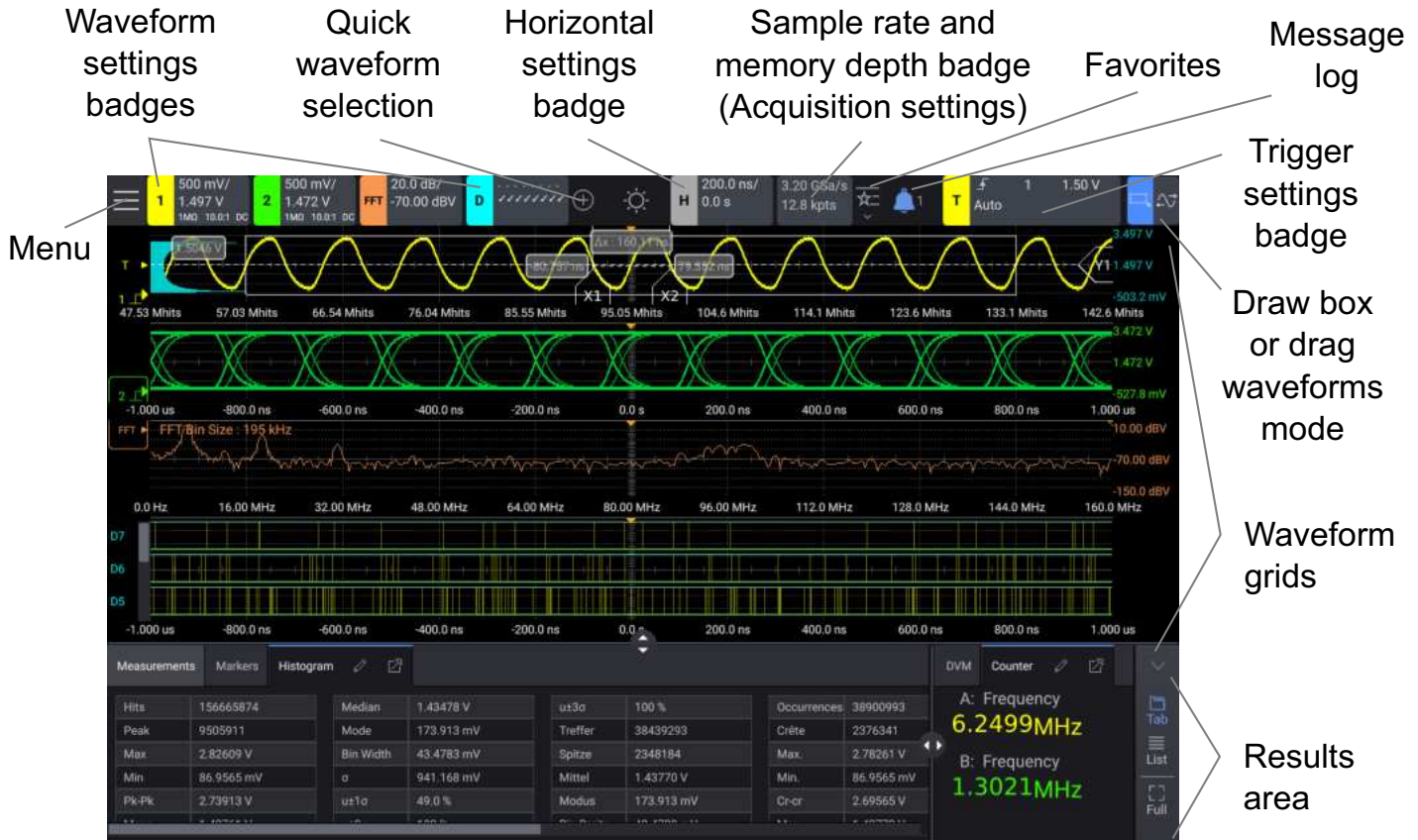
- 3 Reinstall the front panel knobs.

Front panel overlays may be ordered from [www.keysight.com/find/parts](http://www.keysight.com/find/parts) using the following part numbers:

Language	2 Channel Overlay	4 Channel Overlay
French	54763-94348	54762-94348
German	54763-94346	54762-94346
Italian	54763-94350	54762-94350
Japanese	54763-94349	54762-94349

Language	2 Channel Overlay	4 Channel Overlay
Korean	54763-94341	54762-94341
Portuguese	54763-94345	54762-94345
Simplified Chinese	54763-94342	54762-94342
Spanish	54763-94347	54762-94347
Thai	54763-94343	54762-94343
Traditional Chinese	54763-94340	54762-94340

## Using the Touchscreen User Interface



When the **[Touch]** key is lit, you can control the oscilloscope by touching different areas of the screen. You can:

- **"Access Features From the Menu"** on page 36
- **"View and Change Settings With Badges"** on page 36
- **"Quick-Select Waveforms to Display"** on page 37

- "Lay Out Waveform Grids" on page 37
- "View Waveforms in a Grid" on page 39
- "Drag Markers" on page 40
- "Customize the Favorites Menu" on page 40
- "View Logged Messages" on page 40
- "Select Draw Box or Drag Waveforms Mode" on page 40
- "View Results" on page 42
- "Enter Names Using Alpha-Numeric Keypad Dialogs" on page 42
- "Use a USB Mouse and/or Keyboard for Touchscreen Controls" on page 42
- "Access the Built-In Online Help" on page 43

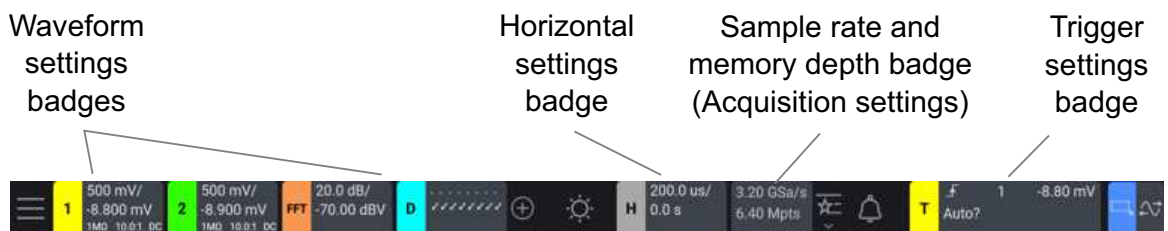
## Access Features From the Menu

Use the upper-left menu to access oscilloscope features and settings.



## View and Change Settings With Badges


These badges appear at the top of the screen:

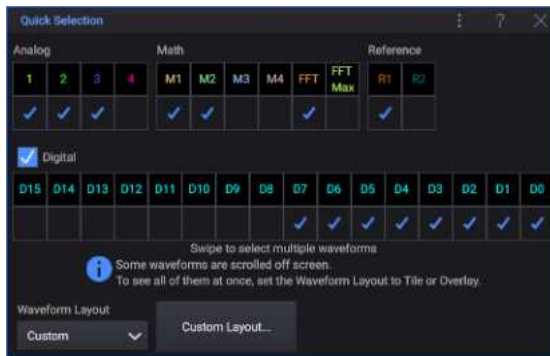


- Waveform settings badges
- Horizontal settings badge
- Sample rate and memory depth badge (Acquisition settings)
- Trigger settings badge

Select the badge to open the settings dialog box.

## Quick-Select Waveforms to Display

Select the  Quick Selection button to open the Quick Selection dialog box.



Check the waveforms you want to display.

## Lay Out Waveform Grids

You can specify the waveform layout in the Quick Selection dialog box or in the Display dialog box (from the menu, choose **Setup > Display...**).

Up to four waveform grids can be stacked (the default), tiled, overlaid, or managed in a custom layout dialog box.

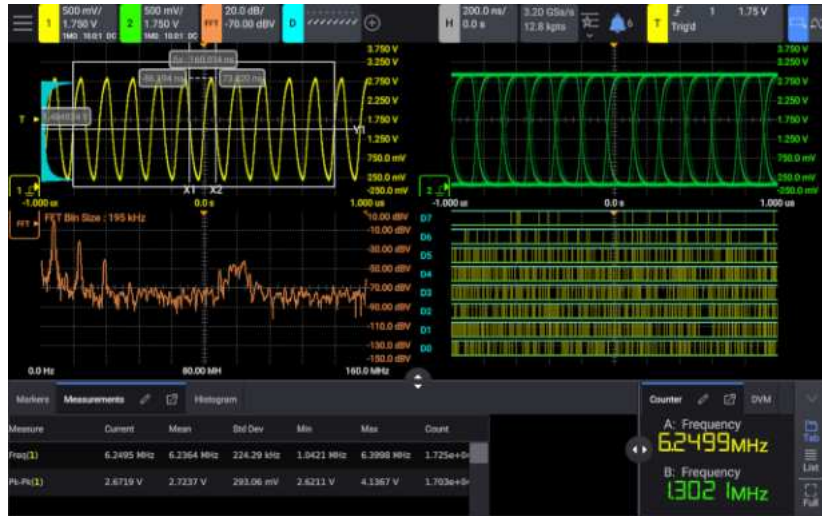


Figure 1 Tiled waveform layout



Figure 2 Overlaid waveform layout

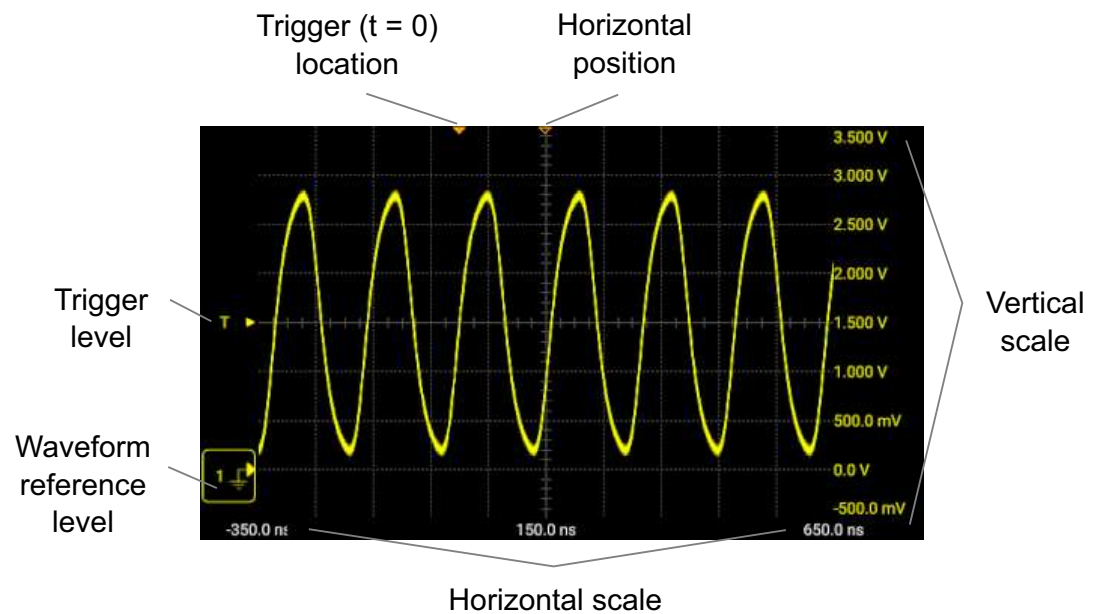


**Figure 3** Custom waveform layout (drag waveforms to grids using dialog box)

## View Waveforms in a Grid

Waveforms displayed within a grid have these features:

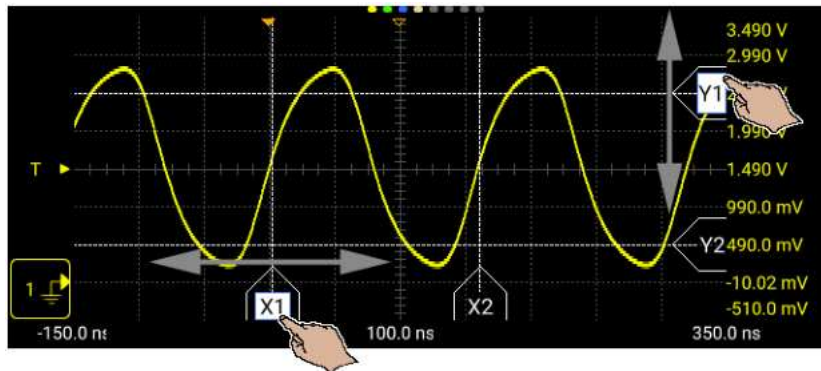
- Draggable waveform reference and trigger levels are shown on the left side of a grid.



- Vertical scale(s) are shown on the right side of a grid. Dual vertical scales can be shown if there are multiple waveforms in a grid.
- The horizontal scale is shown at the bottom of a grid.

## Drag Markers

When markers are turned on in the Markers dialog box (press **[Markers]** or choose **Measure > Markers...** from the main menu), you can drag the name handles to position them.




## Customize the Favorites Menu

You can add your favorite menu items to the Favorites menu for quicker access.




Select **Edit Favorite** to customize the Favorites menu.

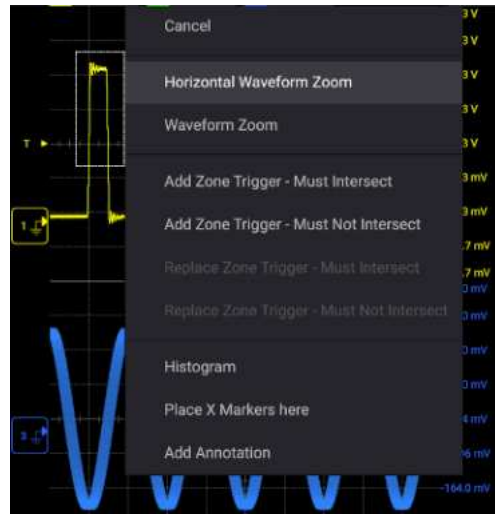
## View Logged Messages


Select the  Message Log button to view information, caution, and failure messages.

## Select Draw Box or Drag Waveforms Mode

Draw box or Drag waveforms mode:


-  Draw box mode – Drag a box and release to access a menu of possible actions for the selected waveform area.



- **Cancel** – Closes the popup menu.
  - **Horizontal Waveform Zoom** – Changes the horizontal scaling and position to zoom the waveform within the drawn box. See [Chapter 2](#), "Horizontal Controls," starting on page 45.
  - **Waveform Zoom** – Changes the horizontal scaling and position, as well as the vertical scaling and offset, to zoom the waveform within the drawn box. See [Chapter 2](#), "Horizontal Controls," starting on page 45 and [Chapter 3](#), "Vertical Controls," starting on page 55.
  - **Add Zone Trigger - Must Intersect, Add Zone Trigger - Must Not Intersect, Replace Zone Trigger - Must Intersect, Replace Zone Trigger - Must Not Intersect** – Adds or replaces triggering zones based on the drawn box. See ["Zone Qualified Trigger"](#) on page 149.
  - **Histogram** – Turns on a histogram using the drawn box to define the histogram window limits. See ["Waveform Histogram Set Up"](#) on page 214.
  - **Place X Markers here** – Turns on manual markers using the left and right sides of the drawn box as the X marker positions. See ["To make marker measurements"](#) on page 178.
  - **Add Annotation** – Adds an annotation at the upper-left corner of the drawn box. See ["To add an annotation"](#) on page 130.
-  Drag waveforms mode – Drag a waveform left or right in the grid to change the horizontal position. Drag a waveform up or down in the grid to change the vertical offset.



## View Results


The Results area displays the results for markers, measurements, histograms, counters, digital voltmeter (DVM), and more.

You can size the Results area by dragging the  sizing handle up or down. Windows for the different types of results can be tabbed within the area or listed.



**Figure 4** Listed windows in Results area

Use  to undock a window from the Results area or  to re-dock a window.

Select the  Edit button to open the associated settings dialog box.

The results area or the waveform grids can be displayed full-screen.

## Enter Names Using Alpha-Numeric Keypad Dialogs

Some fields open alpha-numeric dialogs that let you touch to enter names.



## Use a USB Mouse and/or Keyboard for Touchscreen Controls

Connecting a USB mouse gives you a mouse pointer on the display. Mouse clicks and drags behave the same as screen touches and finger drags.

If you connect a USB keyboard, you can use it to enter values in alpha-numeric keypad dialogs.

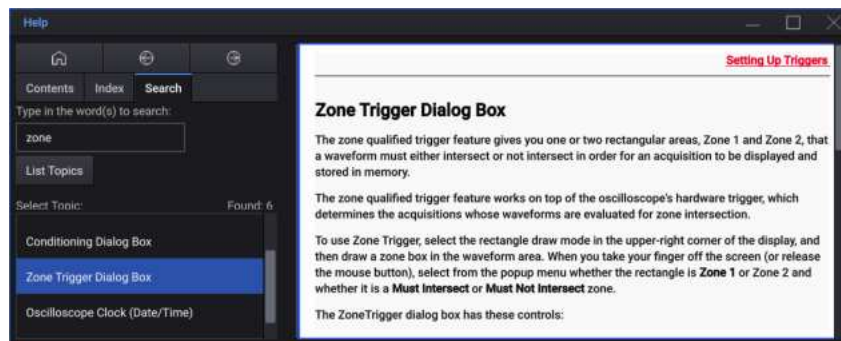
## Access the Built-In Online Help


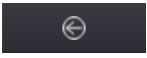
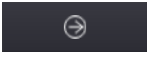
To access the built-in online help, you can:

- From the menu, choose **Help > Help...**
- Most user interface dialog boxes have a **?** help button next to the **X** close button.

Select the **?** to open the online help for the dialog box.

The Help viewer dialog box has these features:



-  Home button – goes to the home topic.
-  Previous button – goes to the previous topic in the navigation sequence.
-  Next button – (after using the Previous button) goes to the next topic in the navigation sequence.
- **Contents** tab – lists the hierarchy of help topics.  
Select a topic in the list to navigate to that topic.
- **Index** tab – contains a list of indexed keywords.  
Select a keyword in the list to navigate to the topic where the keyword is mentioned.  
Use the field above the list to list only those keywords that contain the string.
- **Search** tab – lets you search the online help for topics in which the entered words are found.

Enter the words to search for. Then, select **List Topics**.

- The Help viewer dialog box cannot be resized, but it can be minimized, maximized, or dragged off the right side and/or bottom of the screen.
- You can resize the left-side navigation pane by dragging the vertical bar between it and the topic viewer pane left or right.

## 2 Horizontal Controls

To adjust the horizontal scale (time/div) / 46

To adjust the horizontal delay (position) / 47

Panning and Zooming Single or Stopped Acquisitions / 48

To display the zoomed time base / 48

To change the horizontal scale coarse/fine adjustment setting / 50

To position the time reference (left, center, right, custom) / 50

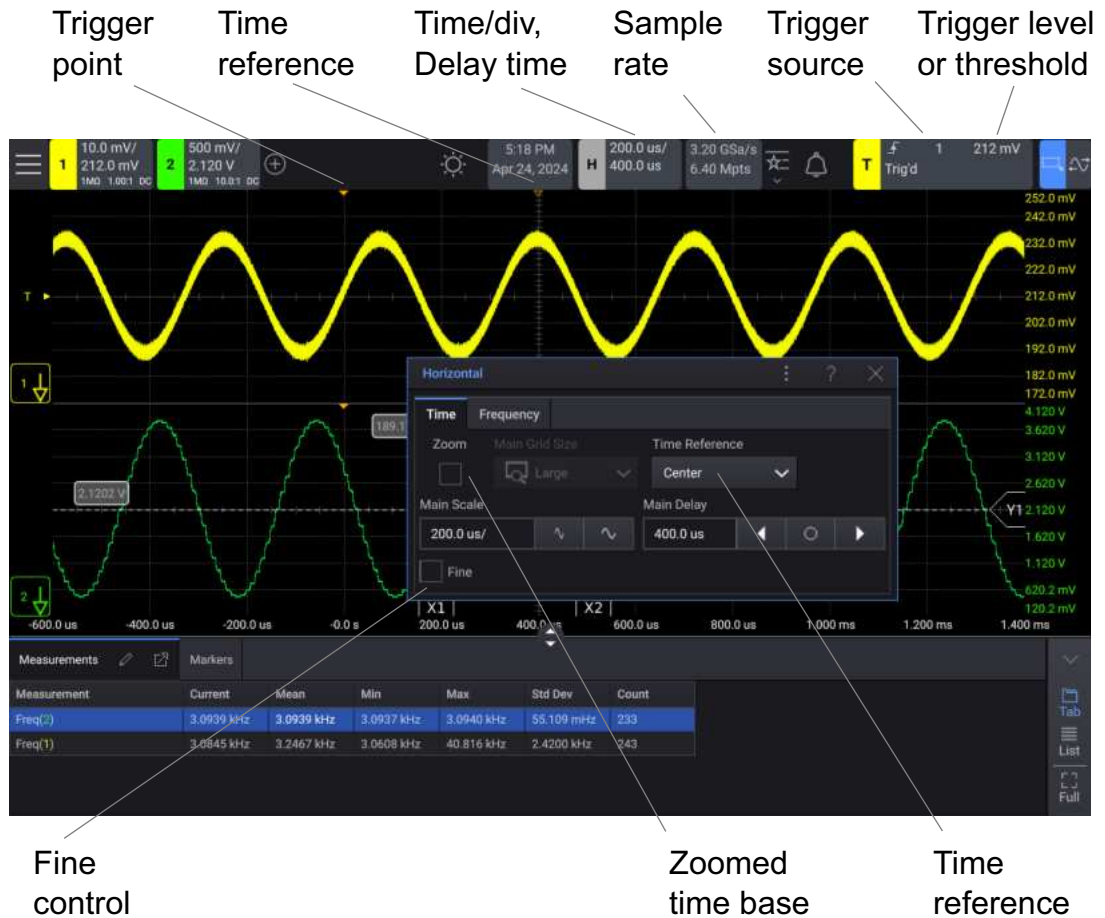
Searching for Events / 51

Navigating the Time Base / 52

The horizontal controls include:

- The horizontal scale and position knobs.
- The horizontal settings badge and **Setup > Horizontal...** menu item for accessing the Horizontal dialog box.
- The **[Zoom]** zoom key for quickly enabling/disabling the split-screen zoom display.
- The **Analyze > Search...** menu item and Search dialog box for finding events on analog channels or in protocol decode.
- The **Analyze > Navigate...** menu item and Navigate dialog box for navigating time, search events, or segmented memory acquisitions.

The following figure shows controls in the Horizontal dialog box.




The Horizontal dialog box lets you enable Zoom, set the time base Fine control (vernier), and specify the time reference.

The current sample rate is displayed in the acquisition settings badge.

## To adjust the horizontal scale (time/div)

You can adjust the horizontal scale in these ways:

- Turn the large horizontal scale (sweep speed) knob marked  to change the horizontal time/div setting.

Note that the horizontal scale knob has a different purpose in the Zoom display. See **"To display the zoomed time base"** on page 48.

- Use the **Main Scale** controls in the Horizontal dialog box (that you can open by selecting the Horizontal badge or by choosing **Setup > Horizontal...** from the main menu).

As you adjust the horizontal scale, notice how the time/div information in the Horizontal badge changes.

The ▽ symbol at the top of the waveform grid indicates the time reference point.

You can adjust the horizontal scale (in the Normal time mode) while acquisitions are running or when they are stopped. When running, adjusting the horizontal scale can change the sample rate and memory depth. When stopped, adjusting the horizontal scale lets you zoom into acquired data. See "[Panning and Zooming Single or Stopped Acquisitions](#)" on page 48.

## To adjust the horizontal delay (position)

You can adjust the horizontal delay in these ways:

- Turn the horizontal delay (position) knob (◀▶).

Note that the horizontal position knob has a different purpose in the Zoom display. See "[To display the zoomed time base](#)" on page 48.

- In the Drag Waveforms mode (see "[Select Draw Box or Drag Waveforms Mode](#)" on page 40), drag waveforms left or right.
- Use the **Main Delay** controls in the Horizontal dialog box (that you can open by selecting the Horizontal badge or by choosing **Setup > Horizontal...** from the main menu).

Changing the delay time moves the trigger point (solid inverted triangle) horizontally and indicates how far it is from the time reference point (hollow inverted triangle ▽). These reference points are indicated along the top of the waveform grid. The trigger point pauses at 0.00 s, mimicking a mechanical detent. The delay value is displayed in the Horizontal badge.

The delay time value tells you how far the time reference point is located from the trigger point. When delay time is set to zero, the delay time indicator overlays the time reference indicator.

All events displayed left of the trigger point happened before the trigger occurred. These events are called pre-trigger information, and they show events that led up to the trigger point.

Everything to the right of the trigger point is called post-trigger information. The amount of delay range (pre-trigger and post-trigger information) available depends on the time/div selected and memory depth.

When acquisitions are running (in the Normal time mode), adjusting the horizontal position changes the amount of pre-trigger and post-trigger data. When stopped, adjusting the horizontal position pans through the last-acquired data. See "[Panning and Zooming Single or Stopped Acquisitions](#)" on page 48.

## Panning and Zooming Single or Stopped Acquisitions

When the oscilloscope is stopped, use the horizontal scale and position knobs to pan and zoom your waveform. The stopped display may contain several acquisitions worth of information, but only the last acquisition is available for pan and zoom.

The ability to pan (move horizontally) and scale (expand or compress horizontally) an acquired waveform is important because of the additional insight it can reveal about the captured waveform. This additional insight is often gained from seeing the waveform at different levels of abstraction. You may want to view both the big picture and the specific little picture details.

The ability to examine waveform detail after the waveform has been acquired is a benefit generally associated with digital oscilloscopes. Often, this is simply the ability to freeze the display for the purpose of measuring with markers or printing the screen. Some digital oscilloscopes go one step further by including the ability to further examine the signal details after acquiring them by panning through the waveform and changing the horizontal scale.

There is no limit imposed on the scaling ratio between the time/div used to acquire the data and the time/div used to view the data. There is, however, a useful limit. This useful limit is somewhat a function of the signal you are analyzing.

**NOTE****Zooming into stopped acquisitions**

The screen will still contain a relatively good display if you zoom-in horizontally by a factor of 1000 and zoom-in vertically by a factor of 10 to display the information from where it was acquired. Remember that you can make automatic measurements on displayed data only.

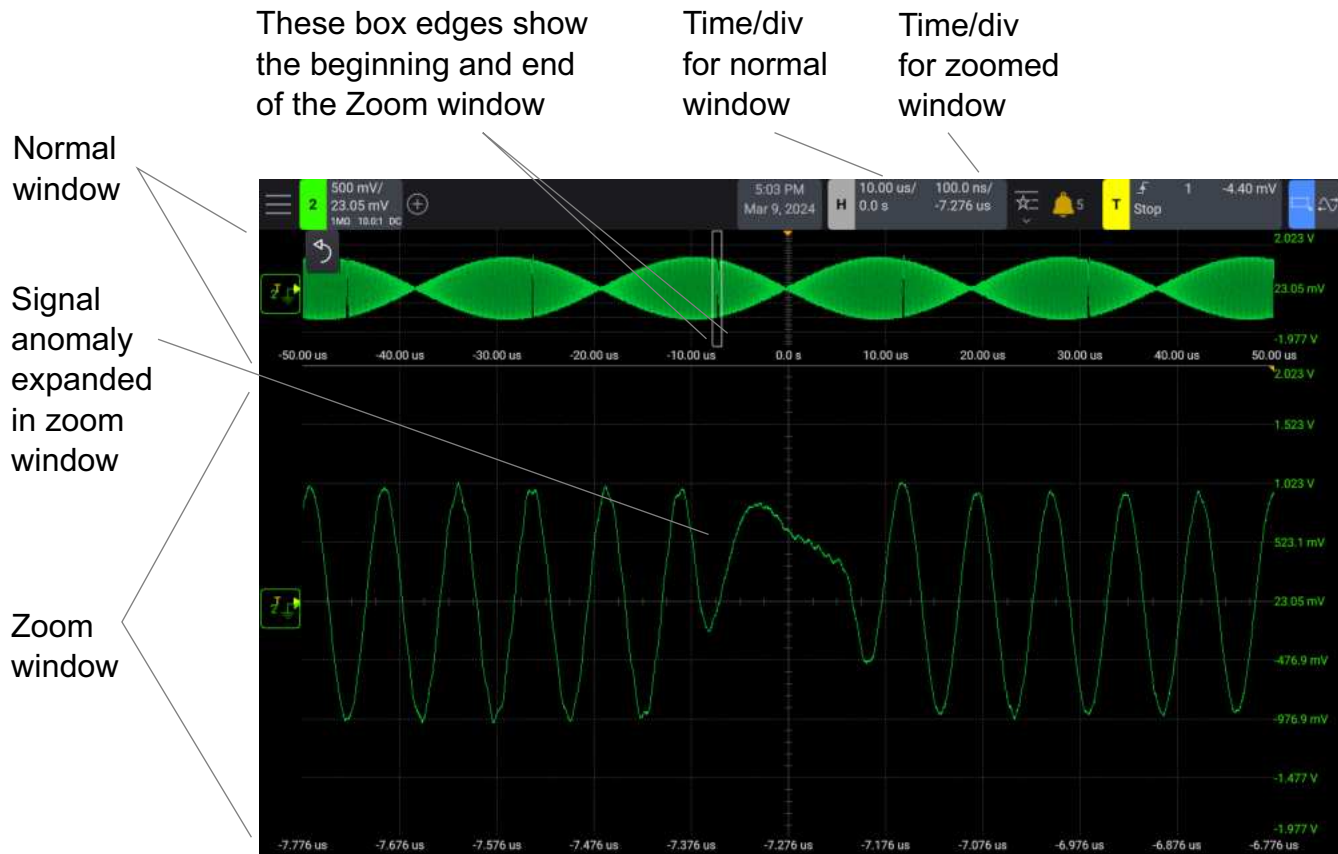
## To display the zoomed time base

Zoom, formerly called Delayed sweep mode, is a horizontally expanded version of the normal display. When Zoom is selected, the display divides into a normal time/div window and a faster Zoom time/div window.

The Zoom window is a magnified portion of the normal time/div window. You can use Zoom to locate and horizontally expand part of the normal window for a more detailed (higher-resolution) analysis of signals.

To turn on (or off) Zoom:

- 1 Press the **[Zoom]** key (or select **Zoom** in the Horizontal dialog box).



The area of the normal display that is expanded is outlined with a box. The box shows the portion of the normal sweep that is expanded in the lower window.

To change the time/div for the Zoom window, turn the horizontal scale (sweep speed) knob. As you turn the knob, the zoomed window time/div is highlighted in the Horizontal badge. The Horizontal scale (sweep speed) knob controls the size of the box.

The Horizontal position (delay time) knob sets the left-to-right position of the zoom window. The delay value, which is the time displayed relative to the trigger point) is momentarily displayed in the upper-right portion of the display when the delay time (◀▶) knob is turned.

Negative delay values indicate you are looking at a portion of the waveform before the trigger event, and positive values indicate you're looking at the waveform after the trigger event.

To change the time/div of the normal window, turn off Zoom; then, turn the horizontal scale (sweep speed) knob.

For information about using zoom mode for measurements, refer to **"To isolate a pulse for Top measurement"** on page 192 and **"To isolate an event for frequency measurement"** on page 197.

## To change the horizontal scale coarse/fine adjustment setting

You can do one of these things:

- Push the horizontal scale knob to toggle between fine and coarse adjustment of the horizontal scale.
- Select the **Fine** option in the Horizontal dialog box (that you can open by selecting the Horizontal badge or by choosing **Setup > Horizontal...** from the main menu).

When **Fine** is enabled, turning the horizontal scale knob changes the time/div (displayed in the status line at the top of the display) in smaller increments. The time/div remains fully calibrated when **Fine** is on.

When **Fine** is turned off, the Horizontal scale knob changes the time/div setting in a 1-2-5 step sequence.

## To position the time reference (left, center, right, custom)

Time reference is the reference point on the display for delay time (horizontal position).

- 1 Open the Horizontal dial box by selecting the Horizontal badge or by choosing **Setup > Horizontal...** from the main menu.
- 2 In the Horizontal Menu, press **Time Reference**; then, select:
  - **Left** – the time reference is set to one major division from the left edge of the display.
  - **Center** – the time reference is set to the center of the display.
  - **Right** – the time reference is set to one major division from the right edge of the display.
  - **Custom Location** – lets you place the time reference location at a percent of the graticule width (where 0% is the left edge and 100% is the right edge).

A small hollow triangle (▽) at the top of the display grid marks the position of the time reference. When delay time is set to zero, the trigger point indicator (▼) overlays the time reference indicator.

The time reference position sets the initial position of the trigger event within acquisition memory and on the display, with delay set to 0.

Turning the Horizontal scale (sweep speed) knob expands or contracts the waveform about the time reference point (∇). See ["To adjust the horizontal scale \(time/div\)"](#) on page 46.

Turning the Horizontal position (◀▶) knob in Normal mode (not Zoom) moves the trigger point indicator (▼) to the left or right of the time reference point (∇). See ["To adjust the horizontal delay \(position\)"](#) on page 47.

## Searching for Events

You can use the **Analyze > Search...** menu item and Search dialog box to search for Edge, Pulse Width, Rise/Fall Time, Frequency Peaks, and Protocol Decode events on the analog channels.

Setting up searches (see ["To set up searches"](#) on page 51) is similar to setting up triggers. In fact, except for Frequency Peaks and Protocol Decode events, you can copy search setups to trigger setups and vice-versa (see ["To copy search setups"](#) on page 52).

Searches are different than triggers in that they use the measurement threshold settings instead of trigger levels.

Found search events are marked with white triangles at the top of the grid, and the number of events found is displayed in the listing on the right side of the display.

### To set up searches

- 1 From the menu, choose **Analyze > Search...**
- 2 In the Search dialog box, select **On**.
- 3 Select the **Search Type**, and use the additional controls to set up the selected search type.

In most cases, setting up searches is similar to setting up triggers:

- For setting up Edge searches, see ["Edge Trigger"](#) on page 137.
- For setting up Pulse Width searches, see ["Pulse Width Trigger"](#) on page 139.
- For setting up Rise/Fall Time searches, see ["Rise/Fall Time Trigger"](#) on page 144.
- For setting up Frequency Peak searches, see ["Searching for FFT Peaks"](#) on page 70.
- For setting up Protocol searches, see ["Protocol Trigger"](#) on page 149 and ["Searching Lister Data"](#) on page 121.

Remember that searches use the measurement threshold settings instead of trigger levels. Select **Thresholds...** to open the Measurement Threshold dialog box. See ["Measurement Thresholds"](#) on page 207.

## To copy search setups

Except for Frequency Peak and Protocol event search setups, you can copy search setups to trigger setups and vice-versa.

- 1 From the menu, choose **Analyze > Search...**
- 2 In the Search dialog box, select **On**.
- 3 Select the **Search Type**, and use the additional controls to set up the selected search type.
- 4 Select **Copy...**
- 5 In the Copy dialog box:
  - Select **Copy to Trigger** to copy the setup for the selected search type to the same trigger type. For example, if the current search type is Pulse Width, selecting **Copy to Trigger** copies the search settings to the Pulse Width trigger settings and selects the Pulse Width trigger.
  - Select **Copy from Trigger** to copy the trigger setup for the selected search type to the search setup.
  - To undo a copy, select **Undo Copy**.

The buttons in the Copy dialog box may not be available when one of the settings cannot be copied or there is no trigger type that corresponds to the search type.






## Navigating the Time Base

You can use the **Analyze > Navigate...** menu item, Navigate dialog box, and navigation controls to navigate through:

- Captured data (see **"To navigate time"** on page 52).
- Search events (see **"To navigate search events"** on page 53).
- Segments, when segmented memory acquisitions are turned on (see **"To navigate segments"** on page 53).



## To navigate time

When acquisitions are stopped, you can use the navigation controls to play through the captured data.


- 1 From the menu, choose **Analyze > Navigate...**
- 2 In the Navigate dialog box, select the **Time** navigation type.
- 3 Select the    navigation buttons to play backward, stop, or play forward in time. You can select the  or  buttons multiple times to speed up the playback. There are three speed levels.

## To navigate search events

When acquisitions are stopped, you can use the navigation controls to go to found search events (set using **Analyze > Search...** and the Search dialog box, see "**Searching for Events**" on page 51).

- 1 From the menu, choose **Analyze > Navigate...**
- 2 In the Navigate dialog box, select the **Search** navigation type.
- 3 Select the   back and forward navigation buttons to go to the previous or next search event.

When searching Protocol Decode:







- You can press the  stop key to set or clear a mark.
- The **Auto zoom** option specifies whether the waveform display is automatically zoomed to fit the marked row as you navigate.
- The **Scroll Lister** option lets you use the Entry knob to scroll through data rows in the Lister display.

## To navigate segments

When the segmented memory acquisition is enabled and acquisitions are stopped, you can use the navigation controls to play through the acquired segments.

- 1 From the menu, choose **Analyze > Navigate...**
- 2 In the Navigate dialog box, select the **Segments** navigation type.
- 3 For the **Play Mode**, you can select:
  - **Manual** – to play through segments manually.

In the Manual play mode:

- Select the   back and forward buttons to go to the previous or next segment.
- Select the  button to go to the first segment.
- Select the  button to go to the last segment.
- Select the  button to go to the next page of segments.
- Select the  button to go to the previous page of segments.
- **Auto** – to play through segments in an automated fashion.

In the Auto play mode:

- Select the ◀ ◼ ▶ navigation buttons to play backward, stop, or play forward in time. You can select the ◀ or ▶ buttons multiple times to speed up the playback. There are three speed levels.

## 3 Vertical Controls

To turn waveforms on or off / 56

To adjust the vertical scale / 57

To adjust the vertical position / 57

To specify channel coupling / 57

To specify channel input impedance / 58

To specify bandwidth limiting / 59

To change the vertical scale knob's coarse/fine adjustment setting / 59

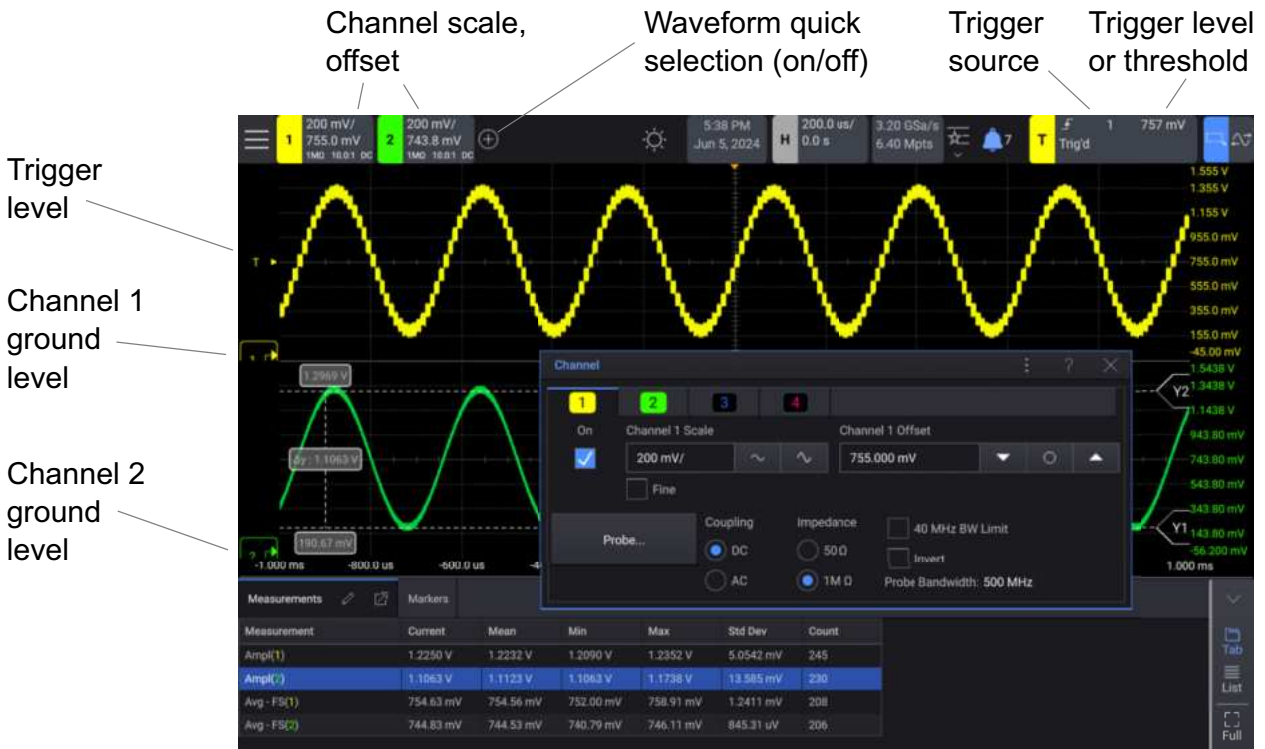
To invert a channel waveform / 60


Setting Analog Channel Probe Options / 60

The vertical controls include:

- Multiplexed vertical scale and position knobs for the analog input channels.
- The channel keys for turning a channel on or off.
- Touchscreen waveform badge controls for setting the vertical scale and position (offset) and accessing the settings dialog boxes.

The following figure shows vertical controls in the Channel dialog box.



The ground level of the signal for each displayed analog channel is identified by the position of the  icon at the far-left side of the display.


### To turn waveforms on or off

- Press an analog channel key turn the channel on or off.  
When a channel is on, its key is lit.

#### NOTE


#### Turning channels off

A channel must be selected for vertical knob adjustment—as shown by the LED next to the channel key—before pressing the channel key will turn off the channel. For example, if channel 1 and channel 2 are turned on and the vertical knobs are enabled for channel 2, to turn channel 1 off, press [1] to enable the vertical knobs for channel 1; then, press [1] again to turn channel 1 off.

- On the touchscreen, you can quickly turn waveforms on or off using the  Quick Selection button and dialog box. Also, dialog boxes under the **Sources** > menu have controls for turning waveforms on or off.

## To adjust the vertical scale

You can do one of these things:

- Turn the large vertical scale knob marked  to set the vertical scale (units/division) for the selected channel.
- Use the **Scale** controls in the waveform dialog box (that you can open by selecting the waveform badge or by choosing **Sources > (waveform)...** from the main menu).


The vertical scale knob changes the analog channel scale in a 1-2-5 step sequence (with a 1:1 probe attached) unless fine adjustment is enabled (see ["To change the vertical scale knob's coarse/fine adjustment setting"](#) on page 59).


The analog channel Units/Div value is displayed in the status line.

The default mode for expanding the signal when you adjust the vertical scale is expansion about the ground level of the waveform; however, you can change this to expand about the center of the display. See ["To choose "expand about" center or ground"](#) on page 279.

## To adjust the vertical position

You can do one of these things:

- Turn the small vertical position knob () to move the selected channel's waveform up or down on the display.
- Use the **Offset** controls in the waveform dialog box (that you can open by selecting the waveform badge or by choosing **Sources > (waveform)...** from the main menu).

The offset voltage value represents the voltage difference between the vertical center of the display and the ground level () icon. It also represents the voltage at the vertical center of the display if vertical expansion is set to expand about ground (see ["To choose "expand about" center or ground"](#) on page 279).

## To specify channel coupling

Coupling changes the channel's input coupling to either **AC** (alternating current) or **DC** (direct current).

**TIP**

If the channel is DC coupled, you can quickly measure the DC component of the signal by simply noting its distance from the ground symbol.

If the channel is AC coupled, the DC component of the signal is removed, allowing you to use greater sensitivity to display the AC component of the signal.

- 1 Open the Channel dialog box by selecting the Channel badge or by choosing **Sources > Channel N...** from the main menu.
- 2 In the Channel dialog box, select **Coupling** to select the input channel coupling:
  - **DC** – DC coupling is useful for viewing waveforms as low as 0 Hz that do not have large DC offsets.
  - **AC** – AC coupling is useful for viewing waveforms with large DC offsets.

When AC coupling is chosen, you cannot select 50Ω mode. This is done to prevent damage to the oscilloscope.

AC coupling places a 10 Hz high-pass filter in series with the input waveform that removes any DC offset voltage from the waveform.

Note that Channel Coupling is independent of Trigger Coupling. To change trigger coupling see "[To select the trigger coupling](#)" on page 155.

## To specify channel input impedance

**NOTE**

When you connect an AutoProbe, self-sensing probe, or a compatible InfiniiMax probe, the oscilloscope automatically configures the analog input channels to the correct impedance.

- 1 Open the Channel dialog box by selecting the Channel badge or by choosing **Sources > Channel N...** from the main menu.
- 2 In the Channel dialog box, select the **Impedance**:
  - **50 Ohm** – matches 50 ohm cables commonly used in making high frequency measurements, and 50 ohm active probes.

When **50 Ohm** input impedance is selected, it is displayed with the channel information on-screen.

When AC coupling is selected (see "[To specify channel coupling](#)" on page 57) or excessive voltage is applied to the input, the oscilloscope automatically switches to **1M Ohm** mode to prevent possible damage.

- **1M Ohm** – is for use with many passive probes and for general-purpose measurements. The higher impedance minimizes the loading effect of the oscilloscope on the device under test.

Impedance matching gives you the most accurate measurements because reflections are minimized along the signal path.

- See Also**
- For more information on probing, visit: [www.keysight.com/find/scope\\_probes](http://www.keysight.com/find/scope_probes)
  - Information about selecting a probe can be found in document number *Keysight Oscilloscope Probes and Accessories Selection Guide* (part number 5989-6162EN), available at [www.keysight.com](http://www.keysight.com).

## To specify bandwidth limiting

Each analog input channel has a **40 MHz BW Limit** option that lets you disable or enable a bandwidth limit (using a digital filter). Limiting the channel bandwidth lets you remove unwanted high frequency noise from the waveform and increase the number of bits of vertical resolution.

- 1 Open the Channel dialog box by selecting the Channel badge or by choosing **Sources > Channel N...** from the main menu.
- 2 In the Channel dialog box, select the **40 MHz BW Limit** option.

Note that there is also a **Global BW Limit** selection in the Acquire dialog box that affects all analog input channels. See "[Selecting a Global Bandwidth Limit and Vertical Resolution](#)" on page 171. When the channel bandwidth limit and the global bandwidth limit are both selected, the lower bandwidth limit is applied.

## To change the vertical scale knob's coarse/fine adjustment setting

You can do one of these things:

- Push the vertical scale knob to toggle between fine and coarse adjustment of the vertical scale.
- Select the **Fine** option in the waveform's settings dialog box (that you can open by selecting the waveform badge or by choosing **Sources > (waveform)...** from the main menu).

When **Fine** adjustment is selected, you can change the channel's vertical sensitivity in smaller increments. The channel sensitivity remains fully calibrated when **Fine** is on.

The vertical scale value is displayed in the waveform badge at the top of the display.

When **Fine** is turned off, adjusting the vertical scale goes in a 1-2-5 step sequence.

## To invert a channel waveform

- 1 Open the Channel dialog box by selecting the Channel badge or by choosing **Sources > Channel N...** from the main menu.
- 2 In the Channel dialog box, select **Invert** to invert the channel.

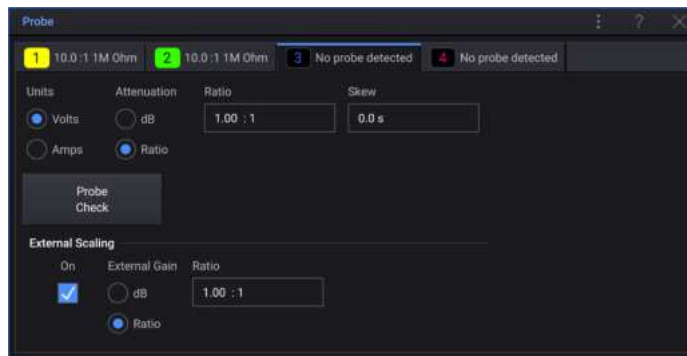
When **Invert** is selected, the voltage values of the displayed waveform are inverted.

Invert affects how a channel is displayed. However, when using basic triggers, the oscilloscope attempts to maintain the same trigger point by changing trigger settings.

Inverting a channel also changes the result of any math function using the channel (see the **Analyze > Math...** menu) or any measurement on the channel.

## Setting Analog Channel Probe Options

- 1 Open the Channel dialog box by selecting the Channel badge or by choosing **Sources > Channel N...** from the main menu.
- 2 In the Channel dialog box, select **Probe...**
- 3 In the Probe dialog box, you select additional probe parameters such as units of measurement, attenuation factor, and skew for the connected probe.



For passive probes (such as the N2862A/B, N2863A/B, N2889A, N2890A, 10073C, 10074C, or 1165A probes), the **Probe Check** button appears; it guides you through the process of compensating probes.

For some active probes (such as InfiniiMax probes), the oscilloscope can accurately calibrate its analog channels for the probe. When you connect a probe that can be calibrated, the **Calibrate Probe** softkey appears (and the probe attenuation softkey may change). See **"To calibrate a probe"** on page 62.

- See Also
- **"To specify the channel units"** on page 61
  - **"To specify the probe attenuation"** on page 61

- "To specify the probe skew" on page 62
- "To specify the channel external scaling" on page 63

## To specify the channel units

- 1 Open the Channel dialog box by selecting the Channel badge or by choosing **Sources > Channel N...** from the main menu.
- 2 In the Channel dialog box, select **Probe...**
- 3 In the Probe dialog box, select the **Units**:
  - **Volts** – for a voltage probe.
  - **Amps** – for a current probe.


Channel sensitivity, trigger level, measurement results, and math functions will reflect the measurement units you have selected.

## To specify the probe attenuation

This is set automatically if the oscilloscope can identify the connected probe. See Analog channel inputs (see [page 22](#)).

The probe attenuation factor must be set properly for accurate measurement results.

If you connect a probe that is not automatically identified by the oscilloscope, you can manually set the attenuation factor as follows:

- 1 Open the Channel dialog box by selecting the Channel badge or by choosing **Sources > Channel N...** from the main menu.
- 2 In the Channel dialog box, select **Probe...**
- 3 In the Probe dialog box, select how you want to specify the **Attenuation** factor, choosing either **Ratio** or **Decibels**.
- 4 Select the attenuation factor field (either **Ratio** or **Decibels**), and turn the Entry knob  to set the attenuation factor for the connected probe.

When measuring voltage values, the attenuation factor can be set from 0.001:1 to 10000:1 in a 1-2-5 sequence.

When measuring current values with a current probe, the attenuation factor can be set from 10 V/A to 0.0001 V/A.


When specifying the attenuation factor in decibels, you can select values from -20 dB to 80 dB.

If **Amps** is chosen as the units and a manual attenuation factor is chosen, then the units as well as the attenuation factor are displayed in the Channel badge.



## To specify the probe skew

When measuring time intervals in the nanoseconds (ns) range, small differences in cable length can affect the measurement. Use **Skew** to remove cable-delay errors between any two channels.

- 1 Probe the same point with both probes.
- 2 For one of the probes, open the Channel dialog box by selecting the Channel badge or by choosing **Sources > Channel N...** from the main menu.
- 3 In the Channel dialog box, select **Probe...**
- 4 Select the **Skew** field, and turn the Entry knob  or enter the desired skew value.

Each analog channel can be adjusted  $\pm 100$  ns in 2.5 ps increments for a total of 200 ns difference.

The skew setting is not affected by pressing **[Default Setup]** or **[Auto Scale]**.

## To calibrate a probe

The **Probe Check** button guides you through the process of calibrating probes.

For certain active probes, such as InfiniiMax probes, the oscilloscope can accurately calibrate its analog channels for the probe. When you connect a probe that can be calibrated, the **Probe Check** button in the Probe dialog box becomes active.

To calibrate one of these probes:

- 1 First, plug your probe into one of the oscilloscope channels.  
This could be, for example, an InfiniiMax probe amplifier/probe head with attenuators attached.
- 2 Connect the probe to the Probe Comp terminal, and the probe ground to the ground terminal.

### NOTE


When calibrating a differential probe, connect the positive lead to the Probe Comp terminal and the negative lead to the ground terminal. You may need to connect an alligator clip to the ground lug to allow a differential probe to span between the Probe Comp test point and ground. A good ground connection ensures the most accurate probe calibration.

- 3 Open the Channel dialog box by selecting the Channel badge or by choosing **Sources > Channel N...** from the main menu.
- 4 In the Channel dialog box, select **Probe...**
- 5 In the Probe dialog box, if there is a field for specifying your probe head (and attenuation), select the option that matches the attenuator you are using:
  - 10:1 single-ended browser (no attenuator).
  - 10:1 differential browser (no attenuator).
  - 10:1 (+6 dB Atten) single-ended browser.
  - 10:1 (+6 dB Atten) differential browser.
  - 10:1 (+12 dB Atten) single-ended browser.
  - 10:1 (+12 dB Atten) differential browser.
  - 10:1 (+20 dB Atten) single-ended browser.
  - 10:1 (+20 dB Atten) differential browser.
- 6 Select **Probe Check** and follow the instructions on the display.

For more information on InfiniiMax probes and accessories, see the probe's *User's Guide*.

## To specify the channel external scaling

External scaling lets you apply additional gain to the input channel to account for additional attenuators, adapters, etc., in the probing system.

- 1 Open the Channel dialog box by selecting the Channel badge or by choosing **Sources > Channel N...** from the main menu.
- 2 In the Channel dialog box, select **Probe...**
- 3 In the Probe dialog box's **External Scaling** area:
  - a Select **On** to enable or disable external scaling.
  - b For **External Gain**, select either **Ratio** or **Decibels** to specify how you want to enter the attenuation factor.
  - c Select the attenuation factor field (either **Ratio** or **Decibels**), and turn the Entry knob  to set the attenuation factor for the connected probe.



## 4 FFT Spectral Analysis

FFT is used to compute the fast Fourier transform using analog input channels or a lower math function. FFT takes the digitized time record of the specified source and transforms it to the frequency domain. When the FFT function is selected, the FFT spectrum is plotted on the oscilloscope display as magnitude in dBV versus frequency. The readout for the horizontal axis changes from time to frequency (Hertz) and the vertical readout changes from volts to dB.

Use the FFT function to find crosstalk problems, to find distortion problems in analog waveforms caused by amplifier non-linearity, or for adjusting analog filters.

To display a FFT waveform:

- 1 From the menu, choose **Analyze > FFT...**
- 2 In the FFT dialog box, select **On**.

The following FFT spectrum was obtained by connecting a 2.5 V, 100 kHz square wave to channel 3. The time domain horizontal scale is set to 50  $\mu$ s/div. The channel 3 vertical scale is set to 500 mV/div. The FFT Center frequency is 500 kHz, the frequency Span is 1 MHz, and window is set to Hanning. The FFT waveform vertical scale is set to 20 dBV, and the vertical offset is set to -40.0 dBV.



You can use the X1 and X2 markers to measure frequency values and difference between two frequency values ( $\Delta X$ ). Use the Y1 and Y2 markers to measure amplitude in dB and difference in amplitude ( $\Delta Y$ ).

You can make peak-to-peak, maximum, minimum, and average dB measurements on the FFT waveform. You can also find the frequency value at the first occurrence of the waveform maximum by using the X at Max Y measurement.

The FFT dialog box has these controls:

- **On** – Turns the FFT waveform on or off.
- **Y Scale** – Adjusts the FFT waveform's vertical scale (units/division), making the waveform shorter or taller on the display. The vertical scale is displayed in the FFT badge at the top of the display.

You can also make this adjustment using a touchscreen vertical pinch gesture in waveform drag mode.

The default mode for expanding the signal when you adjust the vertical scale is vertical expansion about the ground level of the waveform; however, you can change this to expand about the center of the display. See "[Setting Oscilloscope Preferences](#)" on page 278.

When **Fine** is not selected (that is, coarse adjustment), the shorter and taller buttons in the dialog box change the vertical scale in a 1-2-5 step sequence. When **Fine** adjustment is selected, you can change the math function's vertical sensitivity in smaller increments.

- **Y Offset** – Adjusts the waveform's vertical offset, moving it up or down on the display. The vertical offset is displayed in the FFT badge at the top of the display.

You can also make this adjustment using the touchscreen in waveform drag mode.

The offset value is the value at the vertical center of the display.

- **Analysis Precision...** – Opens the Analysis Precision dialog box where you can enable the precision analysis record (for measurements and math function waveforms) and specify its length. See "**The Analysis Record and Waveform Math**" on page 95.
- **Input** – Selects how the displayed frequency range is entered:
  - **Center/Span** – **Span** specifies the frequency range represented by the width of the display. Divide span by 10 to calculate the frequency scale per division. **Center** specifies the frequency at the center vertical grid line of the display.
  - **Start/Stop** – **Start Freq** specifies the frequency at the left side of the display. **Stop Freq** specifies the frequency at the right side of the display.
- **Source 1** – Select the analog channel, math function, or reference waveform on which to perform the FFT.
- **Readout** – Specifies how the FFT resolution is displayed: **Off**, **Sample Rate**, **Bin Size**, **RBW** (Resolution Bandwidth).
- **Display Mode** – selects one of these FFT waveform display modes:
  - **Normal** – this is the FFT waveform without any averaging or hold functions applied. This is how FFT math function waveforms are displayed.
  - **Averaged Value** – the FFT waveform is averaged the selected number of times. Averages are calculated using a "decaying average" approximation, where:
 
$$\text{next\_average} = \text{current\_average} + (\text{new\_data} - \text{current\_average})/N$$

Where N starts at 1 for the first acquisition and increments for each following acquisition until it reaches the selected number of averages, where it holds.
- **Max Hold** – records the maximum vertical values found at each horizontal bucket across multiple analysis cycles and uses those values to build a waveform. This display mode is often referred to as Max Envelope.
- **Min Hold** – records the minimum vertical values found at each horizontal bucket across multiple analysis cycles and uses those values to build a waveform. This display mode is often referred to as Min Envelope.
- **Auto Setup** – Sets the frequency **Span** and **Center** to values that will cause the entire available spectrum to be displayed. The maximum available frequency is half the FFT sample rate, which is a function of the time per division setting. The FFT resolution is the quotient of the sampling rate and the number of FFT points ( $f_s/N$ ). The current FFT Resolution is displayed on screen.
- **Add Max Function** – Adds another math function waveform that is the **Max Hold** operator on the FFT math function waveform.

- **Advanced FFT...** – Opens the Advanced FFT dialog box where you can select a window, specify vertical units, select gating, or set up detectors.

The Advanced FFT dialog box has these controls:



- **Window** – Selects a window to apply to your FFT input signal:
  - **Hanning** – window for making accurate frequency measurements or for resolving two frequencies that are close together.
  - **Flat Top** – window for making accurate amplitude measurements of frequency peaks.
  - **Rectangular** – good frequency resolution and amplitude accuracy, but use only where there will be no leakage effects. Use on self-windowing waveforms such as pseudo-random noise, impulses, sine bursts, and decaying sinusoids.
  - **Blackman Harris** – window reduces time resolution compared to a rectangular window, but improves the capacity to detect smaller impulses due to lower secondary lobes.
  - **Bartlett** – (triangular, with end points at zero) window is similar to the Hanning window in that it is good for making accurate frequency measurements, but its higher and wider secondary lobes make it not quite as good for resolving frequencies that are close together.
- **Vertical Units** – For the **FFT (Magnitude)** math function, you can select **Logarithmic** (decibels) or **Linear** (V RMS). For the **FFT (Phase)** math function, you can select **Degrees** or **Radians**.
- **FFT Gating** – When the zoomed time base is displayed, you can select:
  - **No Gating** – The FFT is performed on the source waveform in the upper Main time base window.
  - **Gate By Zoom** – The FFT is performed on the source waveform in the lower Zoom window.
- **Detection Type** – When the **FFT (Magnitude)** operator is selected, this option lets you set the FFT detector decimation type.

Detectors give you a way of manipulating the acquired data to emphasize different features of the data. Detectors reduce (decimate) the number of FFT points to at most the number of specified detector points. In this reduction, sampled FFT points are bucketized, that is, split into a number of groups that equals the specified number of detector points. Then, the points in each bucket are reduced to a single point according to the selected detection type. The detector types are:

- **None** – No detector is used.

- **Sample** – Takes the point nearest to the center of every bucket.
- **+ Peak** – Takes the most positive point in every bucket.
- **- Peak** – Takes the most negative point in every bucket.
- **Average** – Takes the average of all points in every bucket.
- **Normal** – Implements a rosenfell algorithm. This method picks either the minimum or maximum sample in every bucket depending on whether the data is monotonically increasing, decreasing, or varying.

When detectors are used, the FFT's output is decimated, and any analysis is performed on the reduced or detected data set.

- **Points per Span** – When the **FFT (Magnitude)** operator is selected and a detector is used, this field specifies the maximum number of points that detectors should decimate to. This is also the number of buckets that sampled FFT points are grouped into before the selected detection type reduction (decimation) is applied.

The minimum number of points is 640.

The maximum number of points is 64K.

- See Also**
- **"Searching for FFT Peaks"** on page 70
  - **"FFT Measurement Hints"** on page 71
  - **"FFT Units"** on page 72
  - **"FFT DC Value"** on page 72
  - **"FFT Aliasing"** on page 72

The following figure illustrates aliasing. This is the spectrum of a 990 Hz square wave, which has many harmonics. The horizontal time/div setting for the square wave sets the sample rate and results in a FFT resolution of 1.91 Hz. The displayed FFT spectrum waveform shows the components of the input signal above the Nyquist frequency to be mirrored (aliased) on the display and reflected off the right edge.

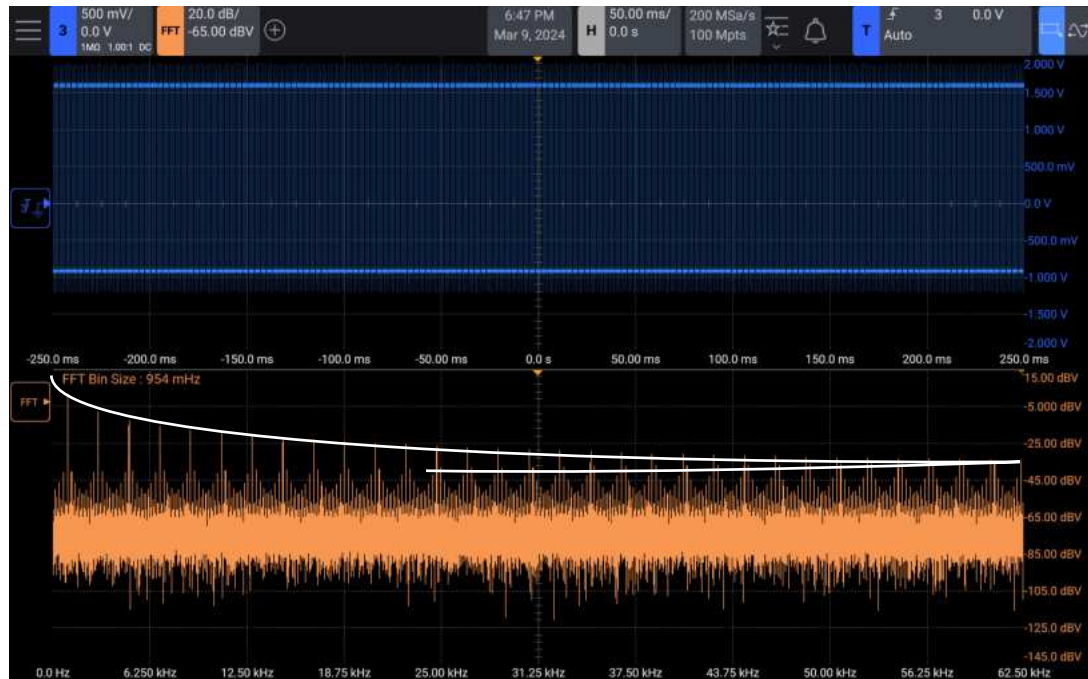


Figure 5 Aliasing

- "FFT Spectral Leakage" on page 73
- "Units for Math Waveforms" on page 78
- For more information on the use of FFTs please refer to Keysight Application Note 243, *The Fundamentals of Signal Analysis* at <http://literature.cdn.keysight.com/litweb/pdf/5952-8898E.pdf>. Additional information can be obtained from Chapter 4 of the book *Spectrum and Network Measurements* by Robert A. Witte.

## Searching for FFT Peaks

With frequency domain waveforms, you can use the Search analysis feature (**Analyze > Search...**) to search for frequency peaks.

In the Search dialog box with the **Freq Peaks** search selected, there are these controls:

- **Max # Peaks** – Specifies the maximum number of FFT peaks to find.
- **Threshold** – Specifies the threshold level necessary to be considered a peak.
- **Excursion** – Specifies the amplitude above the FFT waveform's noise floor necessary to be recognized as a peak.

Note that the FFT waveform's noise floor level differs when additional math functions are applied to the FFT:

- When **Averaged Value**, **Max Hold**, or **Min Hold** are applied, the FFT waveform's noise floor is more stable, and excursion level settings are more accurate.
- When no additional math functions are applied (normal), the FFT waveform's noise floor is less stable and excursion level settings are less accurate.
- **Results Order** – Specifies whether the found FFT peaks should be ordered by frequency or by amplitude.

Your selection also affects the order of found FFT peaks in the "search events found" list.

White arrowheads at the top of the graticule show where FFT peaks are found.

When acquisitions are stopped, you can use the Navigate analysis feature (**Analyze > Navigate...**) to look at the search events found.

## FFT Measurement Hints

The number of points acquired for the FFT record can be up to 65,536, and when frequency span is at maximum, all points are displayed. Once the FFT spectrum is displayed, the frequency span and center frequency controls are used much like the controls of a spectrum analyzer to examine the frequency of interest in greater detail. Place the desired part of the waveform at the center of the screen and decrease frequency span to increase the display resolution. As frequency span is decreased, the number of points shown is reduced, and the display is magnified.

### NOTE

#### FFT Resolution

The FFT resolution is the quotient of the sampling rate and the number of FFT points ( $f_s/N$ ). With a fixed number of FFT points (up to 65,536), the lower the sampling rate, the better the resolution.

Decreasing the effective sampling rate by selecting a greater time/div setting will increase the low frequency resolution of the FFT display and also increase the chance that an alias will be displayed. The resolution of the FFT is the effective sample rate divided by the number of points in the FFT. The actual resolution of the display will not be this fine as the shape of the window will be the actual limiting factor in the FFT's ability to resolve two closely spaced frequencies. A good way to test the ability of the FFT to resolve two closely spaced frequencies is to examine the sidebands of an amplitude modulated sine wave.

For the best vertical accuracy on peak measurements:

- Make sure the probe attenuation is set correctly. The probe attenuation is set from the Channel Menu if the operand is a channel.

- Set the source sensitivity so that the input signal is near full screen, but not clipped.
- Use the Flat Top window.
- Set the FFT sensitivity to a sensitive range, such as 2 dB/division.

For best frequency accuracy on peaks:

- Use the Hanning window.
- Use Cursors to place an X cursor on the frequency of interest.
- Adjust frequency span for better cursor placement.
- Return to the Cursors Menu to fine tune the X cursor.

## FFT Units

**FFT (Magnitude) Units** FFT units are displayed as dB.

**FFT (Phase) Units** In this case, the vertical units are degrees or radians.

## FFT DC Value

The FFT computation produces a DC value that is incorrect. It does not take the offset at center screen into account. The DC value is not corrected in order to accurately represent frequency components near DC.

## FFT Aliasing

When using FFTs, it is important to be aware of frequency aliasing. This requires that the operator have some knowledge as to what the frequency domain should contain, and also consider the sampling rate, frequency span, and oscilloscope vertical bandwidth when making FFT measurements. The FFT resolution (or RBW which is the quotient of the sampling rate and the number of FFT points), sample rate, or bin size can be displayed in the FFT waveform grid.

### NOTE

#### **Nyquist Frequency and Aliasing in the Frequency Domain**

The Nyquist frequency is the highest frequency that any real-time digitizing oscilloscope can acquire without aliasing. This frequency is half of the sample rate. Frequencies above the Nyquist frequency will be under sampled, which causes aliasing. The Nyquist frequency is also called the folding frequency because aliased frequency components fold back from that frequency when viewing the frequency domain.

Aliasing happens when there are frequency components in the signal higher than half the sample rate. Because the FFT spectrum is limited by this frequency, any higher components are displayed at a lower (aliased) frequency.

Because the frequency span goes from  $\approx 0$  to the Nyquist frequency, the best way to prevent aliasing is to make sure that the frequency span is greater than the frequencies of significant energy present in the input signal.

## FFT Spectral Leakage

The FFT operation assumes that the time record repeats. Unless there is an integral number of cycles of the sampled waveform in the record, a discontinuity is created at the end of the record. This is referred to as leakage. In order to minimize spectral leakage, windows that approach zero smoothly at the beginning and end of the signal are employed as filters to the FFT. The FFT Menu provides these windows: Hanning, Flat Top, Rectangular, Blackman-Harris, and Bartlett.



## 5 Math Waveforms

To display math waveforms /	75
Units for Math Waveforms /	78
Arithmetic Math Functions /	78
Transforms Math Functions /	80
FFT Math Functions /	88
Filters Math Functions /	90
Visualizations Math Functions /	93
The Analysis Record and Waveform Math /	95

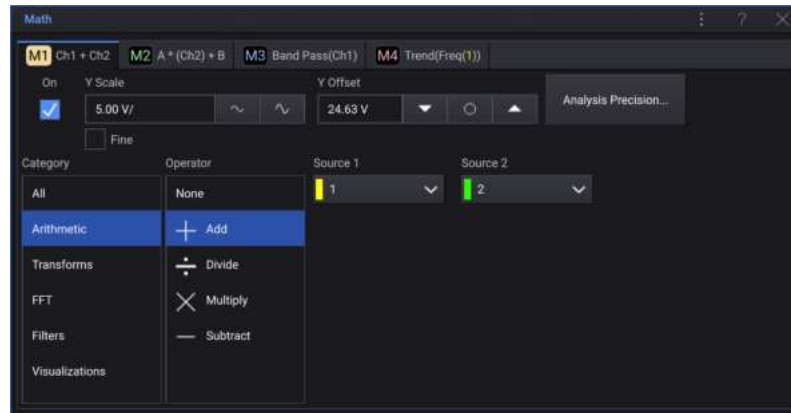
In addition to the dedicated FFT function (see [Chapter 4](#), “FFT Spectral Analysis,” starting on page 65), you can define four other math functions.

Math functions can be performed on analog channels or they can be performed on lower math functions when using operators other than add, subtract, multiply, or divide.

### To display math waveforms

- 1 From the menu, choose **Analyze > Math...**

The Math dialog box has tabs for the four available math function waveforms, M1, M2, M3, and M4.



- 2 In the tab for the math function you want to use, select **On**.
- 3 From the **Operator** list, select the arithmetic, transform, FFT, filter, or visualization math function you want to display.

To filter the operator list, you can select the **Category** of operators you want to select from:

- **All** – All math function operators.
  - **Arithmetic** – Only arithmetic math function operators (add, subtract, multiply, or divide of two waveform sources). See "[Arithmetic Math Functions](#)" on page 78.
  - **Transforms** – Only math function operators that transform a single waveform source (for example, differentiate, integrate, logarithm, exponential). See "[Transforms Math Functions](#)" on page 80.
  - **FFT** – Only FFT math function operators (FFT magnitude or FFT phase). See "[FFT Math Functions](#)" on page 88.
  - **Filters** – Only math function operators that apply filters to a single waveform source (for example, low-pass, high-pass, band-pass, smoothing). See "[Filters Math Functions](#)" on page 90.
  - **Visualizations** – Only math function operators that plot selected values (for example, maximum, minimum, measurement trend, chart). See "[Visualizations Math Functions](#)" on page 93.
- 4 Use the **Source 1** drop-down list to select the analog channel, lower math function, or reference waveform on which to perform math.

Higher math functions can operate on lower math functions when using operators other than the simple arithmetic operations (+, -, \*, /). For example, if **Math 1** is set up as a subtract operation between channels 1 and 2, the **Math 2** function could be set up as a FFT operation on the Math 1 function. These are called cascaded math functions.

To cascade math functions, select the lower math function using the **Source 1** drop-down-list.

**TIP**

When cascading math functions, to get the most accurate results, be sure to vertically scale lower math functions so that their waveforms take up the full screen without being clipped.

- 5 If you selected an arithmetic operator for the math function, use the **Source 2** drop-down list to select the second source for the arithmetic operation.
- 6 To re-size and re-position the math waveform, use the **Y Scale** and **Y Offset** controls:

- **Y Scale** – Adjusts the math function waveform's vertical scale (units/division), making the waveform shorter or taller on the display. The vertical scale is displayed in the math function badge at the top of the display.

You can also make this adjustment using a touchscreen vertical pinch gesture in waveform drag mode.

The default mode for expanding the signal when you adjust the vertical scale is vertical expansion about the ground level of the waveform; however, you can change this to expand about the center of the display. See **"To choose "expand about" center or ground"** on page 279.

When **Fine** is not selected (that is, coarse adjustment), the shorter and taller buttons in the dialog box change the vertical scale in a 1-2-5 step sequence. When **Fine** adjustment is selected, you can change the math function's vertical sensitivity in smaller increments.

**NOTE****Math Scale and Offset are Set Automatically**

Any time the currently displayed math function definition is changed, the function is automatically scaled for optimum vertical scale and offset. If you manually set scale and offset for a function, select a new function, then select the original function, the original function will be automatically rescaled.

- **Y Offset** – Adjusts the waveform's vertical offset, moving it up or down on the display. The vertical offset is displayed in the math function badge at the top of the display.

You can also make this adjustment using the touchscreen in waveform drag mode.

The offset voltage value represents the voltage difference between the vertical center of the display and the ground level ( ) icon. It also represents the voltage at the vertical center of the display if vertical expansion is set to expand about ground (see **"To choose "expand about" center or ground"** on page 279).

**TIP****Math Operating Hints**

If the analog channel or math function is clipped (not fully displayed on screen) the resulting displayed math function will also be clipped.

Once the function is displayed, the analog channel(s) may be turned off for better viewing of the math waveform.

The math function waveform can be measured using markers and/or measurements.

## Units for Math Waveforms

Units for each input channel can be set to **Volts** or **Amps** using the **Units** control in the Probe dialog box. Units for math function waveforms are:

Math function	Units
add or subtract	V or A
multiply	$V^2$ , $A^2$ , or W (Volt-Amp)
d/dt	V/s or A/s (V/second or A/second)
$\int dt$	Vs or As (V-seconds or A-seconds)
FFT	dB* (decibels). See also " <b>FFT Units</b> " on page 72.
$\sqrt{\text{square root}}$	$V^{1/2}$ , $A^{1/2}$ , or $W^{1/2}$ (Volt-Amp)
* When the FFT source is channel 1, 2, 3 or 4, FFT units will be displayed in dBV when channel units is set to Volts and channel impedance is set to 1 M $\Omega$ . FFT units will be displayed in dBm when channel units is set to Volts and channel impedance is set to 50 $\Omega$ . FFT units will be displayed as dB for all other FFT sources or when a source channel's units has been set to Amps.	

A scale unit of **U** (undefined) will be displayed for math functions when two source channels are used and they are set to dissimilar units and the combination of units cannot be resolved.

## Arithmetic Math Functions

Math operators perform arithmetic operations (like add, subtract, or multiply) on analog input channels.

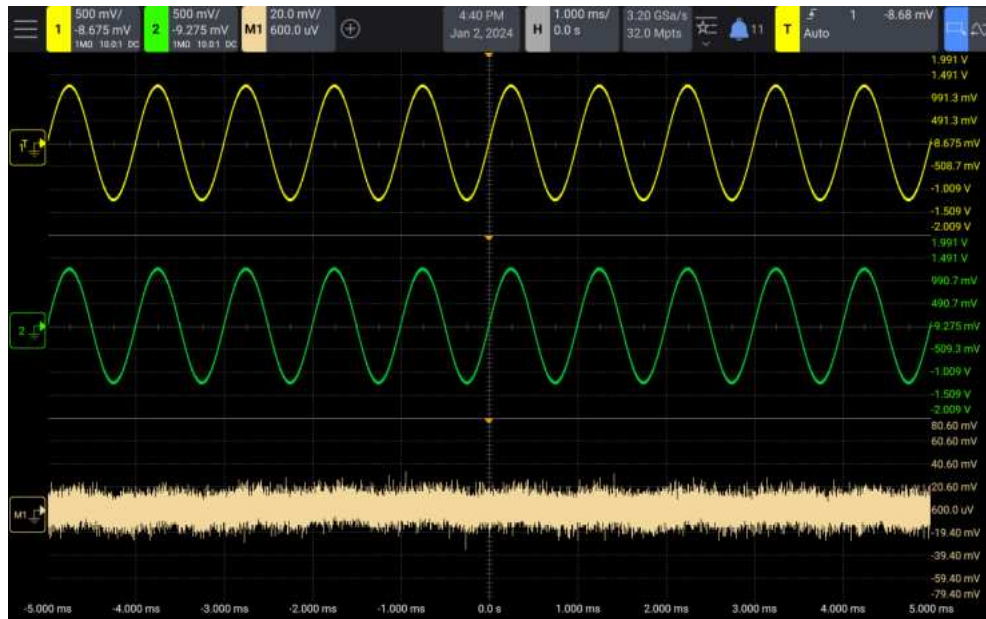
- "**Add or Subtract**" on page 79
- "**Multiply or Divide**" on page 79

## Add or Subtract

When you select add or subtract, the **Source 1** and **Source 2** values are added or subtracted point by point, and the result is displayed.

You can use subtract to make a differential measurement or to compare two waveforms.

If your waveforms' DC offsets are larger than the dynamic range of the oscilloscope's input channels you will need to use a differential probe instead.



**Figure 6** Example of Subtract Channel 2 from Channel 1

See Also · ["Units for Math Waveforms"](#) on page 78

## Multiply or Divide

When you select the multiply or divide math function, the **Source 1** and **Source 2** values are multiplied or divided point by point, and the result is displayed.

The divide by zero case places holes (that is, zero values) in the output waveform.

Multiply is useful for seeing power relationships when one of the channels is proportional to the current.



**Figure 7** Example of Multiply Channel 1 by Channel 2

See Also · ["Units for Math Waveforms"](#) on page 78

## Transforms Math Functions

Math transforms perform a transform function (like differentiate, integrate, FFT, or square root) on an analog input channel or on the result of an arithmetic operation.

- ["Absolute Value"](#) on page 81
- ["Ax + B"](#) on page 81
- ["Base 10 Exponential"](#) on page 82
- ["Common Logarithm"](#) on page 83
- ["Differentiate"](#) on page 83
- ["Exponential"](#) on page 84
- ["Integrate"](#) on page 84
- ["Natural Logarithm"](#) on page 86
- ["Square Root"](#) on page 87
- ["Square"](#) on page 88

## Absolute Value

The absolute value function changes negative values in the input to positive values and displays the resulting waveform.



**Figure 8** Example of Absolute Value

See Also · ["Square"](#) on page 88

## $Ax + B$

The  $Ax + B$  function lets you apply a gain and offset to an existing input source.



**Figure 9** Example of  $Ax + B$

Use the **Gain (A)** field to specify the gain.

Use the **Offset (B)** field to specify the offset.

The  $Ax + B$  function differs from the **Magnify** math visualization function in that the output is likely different than the input.

See Also • **"Magnify"** on page 93

## Base 10 Exponential

The Base 10 Exponential ( $10^x$ ) function performs a transform of the input source.



**Figure 10** Example of Base 10 Exponential

See Also • ["Exponential"](#) on page 84

## Common Logarithm

The Common Logarithm ( $\log$ ) function performs a transform of the input source. Where the transform is undefined for a particular input, holes (zero values) appear in the function output.

See Also • ["Natural Logarithm"](#) on page 86

## Differentiate

**d/dt** (differentiate) calculates the discrete time derivative of the selected source.

You can use differentiate to measure the instantaneous slope of a waveform. For example, the slew rate of an operational amplifier may be measured using the differentiate function.

Because differentiation is very sensitive to noise, it is helpful to set acquisition mode to **Averaging** (see ["Selecting the Acquisition Mode"](#) on page 166).

**d/dt** plots the derivative of the selected source using the "average slope estimate at 4 points" formula. The equation is:

$$d_i = \frac{y_{i+4} + 2y_{i+2} - 2y_{i-2} - y_{i-4}}{8 \Delta t}$$

Where:

- d = differential waveform.
- y = channel 1, 2, 3, 4, or Math 1, Math 2, Math 3 (lower math function) data points.
- i = data point index.
- $\Delta t$  = point-to-point time difference.



**Figure 11** Example of Differentiate Function

See Also • ["Units for Math Waveforms"](#) on page 78

## Exponential

The Exponential ( $e^x$ ) function performs a transform of the input source.

See Also • ["Base 10 Exponential"](#) on page 82

## Integrate

$\int dt$  (integrate) calculates the integral of the selected source. It shows the accumulated amount of change.

You can use integrate to calculate the energy of a pulse in volt-seconds or measure the area under a waveform by measuring the difference in the integrate function value across the pulse or waveform.

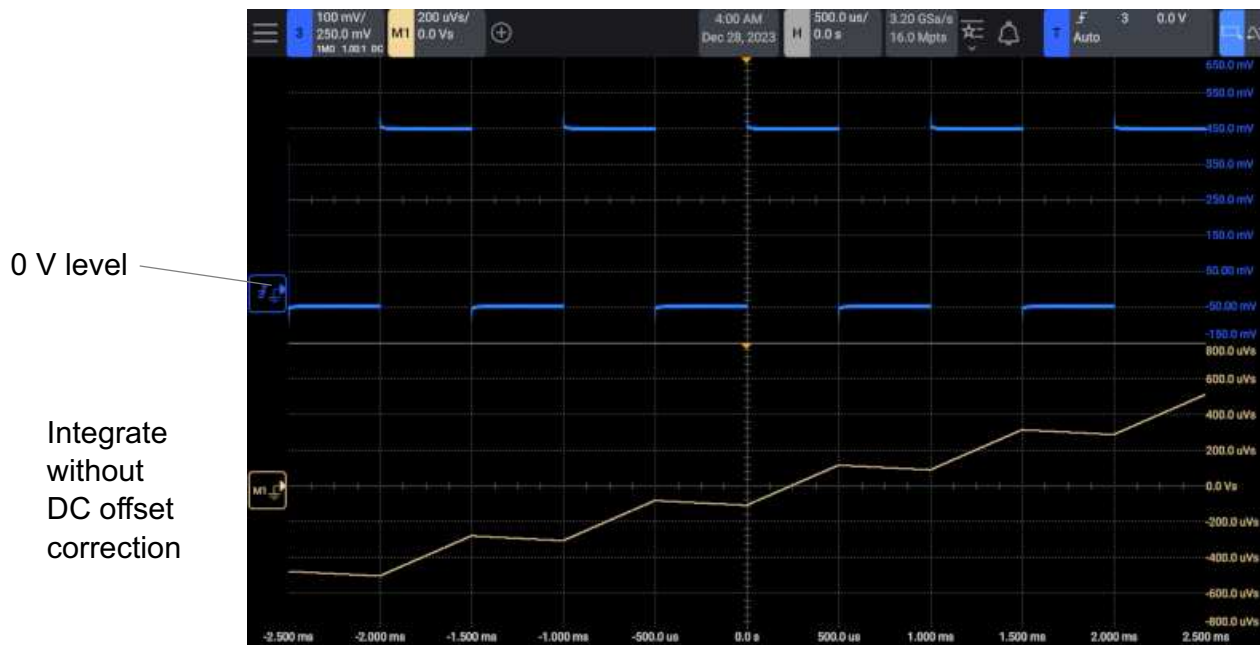
$\int dt$  plots the integral of the source using the "Trapezoidal Rule". The equation is:

$$I_n = c_o + \Delta t \sum_{i=0}^n y_i$$

Where:

- $I$  = integrated waveform.
- $\Delta t$  = point-to-point time difference.
- $y$  = channel 1, 2, 3, 4, or Math 1, Math 2, Math 3 (lower math function) data points.
- $c_o$  = arbitrary constant.
- $i$  = data point index.

The integrate operator provides an **Offset** field that lets you enter a DC offset correction factor for the input signal. Small DC offset in the integrate function input (or even small oscilloscope calibration errors) can cause the integrate function output to "ramp" up or down. This DC offset correction lets you level the integrate waveform.



**Figure 12** Integrate Without Signal Offset

Integrate  
with DC offset  
correction



**Figure 13** Integrate With Signal Offset

When **Initial Condition** is enabled, the integrate math waveform is vertically centered in the screen. In other words, the top and bottom of the math waveform are equal distances from the top and bottom of the screen. When **Initial Condition** is disabled, the integrate math waveform starts at the zero-level reference on the left side of the screen.

See Also • ["Units for Math Waveforms"](#) on page 78

### Natural Logarithm

The Natural Logarithm (ln) function performs a transform of the input source. Where the transform is undefined for a particular input, holes (zero values) appear in the function output.

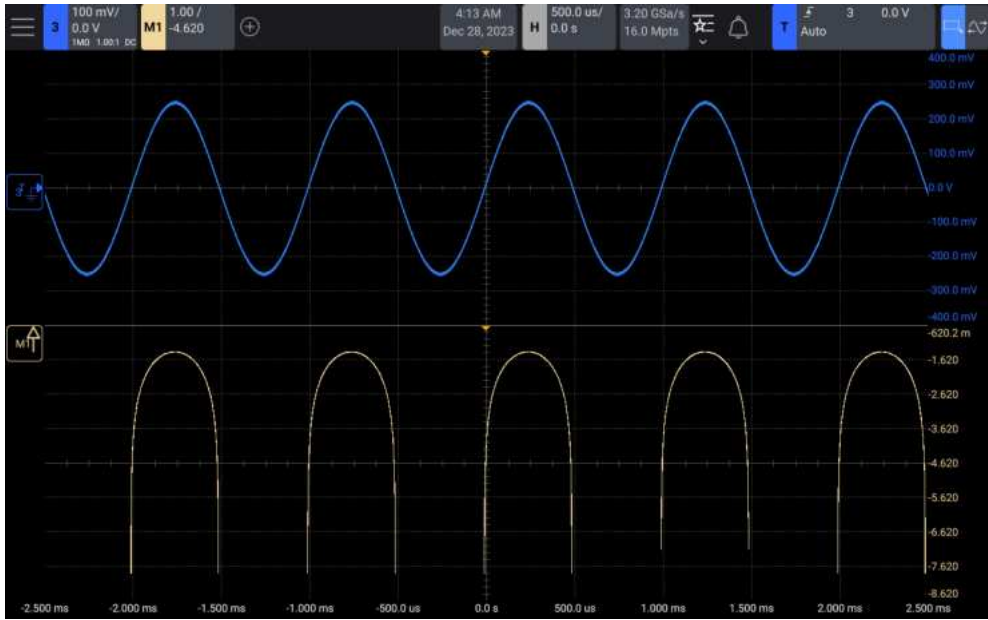


Figure 14 Example of Natural Logarithm

See Also · ["Common Logarithm"](#) on page 83

### Square Root

Square root ( $\sqrt{\phantom{x}}$ ) calculates the square root of the selected source.

Where the transform is undefined for a particular input, holes (zero values) appear in the function output.



**Figure 15** Example of  $\sqrt{\quad}$  (Square Root)

See Also • ["Units for Math Waveforms"](#) on page 78

## Square

The squared function calculates the square of the selected source, point by point, and displays the result.

Use the **Source 1** drop-down list to select the signal source.

See Also • ["Square Root"](#) on page 87

## FFT Math Functions

The FFT math functions let you display a Fast Fourier Transform (FFT) (magnitude or phase) of an analog input channel or of the result of an arithmetic operation.

• ["FFT Magnitude, FFT Phase"](#) on page 88

### FFT Magnitude, FFT Phase

Using the Fast Fourier Transform (FFT), the **FFT (Magnitude)** math function displays the magnitudes of the frequency content that makes up the source waveform, and the **FFT (Phase)** math function shows the phase relationships of the frequency content. The FFT takes the digitized time record of the specified source and transforms it to the frequency domain.

The source of the FFT math functions can be analog input channels or a lower math function.

The horizontal axis of FFT math functions is frequency (Hertz). For the **FFT (Magnitude)** math function, the vertical axis is in decibels when Logarithmic vertical units are selected or V RMS when Linear vertical units are selected. For the **FFT (Phase)** math function, the vertical axis is in degrees or radians.

Use the **FFT (Magnitude)** function to find crosstalk problems, to find distortion problems in analog waveforms caused by amplifier non-linearity, or for adjusting analog filters.

When the **FFT (Magnitude)** or **FFT (Phase)** operators are selected, the Waveform Math dialog box has these additional controls:

- **Input** – Selects how the displayed frequency range is entered:
  - **Center/Span** – **Span** specifies the frequency range represented by the width of the display. Divide span by 10 to calculate the frequency scale per division. **Center** specifies the frequency at the center vertical grid line of the display.
  - **Start/Stop** – **Start Freq** specifies the frequency at the left side of the display. **Stop Freq** specifies the frequency at the right side of the display.
- **Zero Phase Ref** – When the **FFT (Phase)** operator is selected, this control sets the reference point for calculating the FFT Phase function:
  - **Trigger** – the FFT phase is measured from the trigger (time=0) point of the waveform.
  - **Entire Display** – the FFT phase is measured from the beginning of the displayed waveform.
- **Readout** – Specifies how the FFT resolution is displayed: **Off**, **Sample Rate**, **Bin Size**, **RBW** (Resolution Bandwidth).
- **Auto Setup** – Sets the frequency **Span** and **Center** to values that will cause the entire available spectrum to be displayed. The maximum available frequency is half the FFT sample rate, which is a function of the time per division setting. The FFT resolution is the quotient of the sampling rate and the number of FFT points ( $f_s/N$ ). The current FFT Resolution is displayed on screen.
- **Add Max Function** – Adds another math function waveform that is the **Max Hold** operator on the FFT math function waveform.
- **Advanced FFT...** – Opens the Advanced FFT dialog box where you can select a window, specify vertical units, select gating, or set up detectors.

**NOTE****Scale and offset considerations**

If you do not manually change the FFT scale or offset settings, when you turn the horizontal scale knob, the span and center frequency settings will automatically change to allow optimum viewing of the full spectrum.

If you do manually set scale or offset, turning the horizontal scale knob will not change the span or center frequency settings, allowing you see better detail around a specific frequency.

Selecting the FFT **Auto Setup** button will automatically rescale the waveform and span and center will again automatically track the horizontal scale setting.

You can use the X1 and X2 markers to measure frequency values and difference between two frequency values ( $\Delta X$ ). Use the Y1 and Y2 markers to measure amplitude in dB and difference in amplitude ( $\Delta Y$ ).

You can make peak-to-peak, maximum, minimum, and average dB measurements on the FFT waveform. You can also find the frequency value at the first occurrence of the waveform maximum by using the X at Max Y measurement.

- See Also**
- ["Searching for FFT Peaks"](#) on page 70
  - ["FFT Measurement Hints"](#) on page 71
  - ["FFT Units"](#) on page 72
  - ["FFT DC Value"](#) on page 72
  - ["FFT Aliasing"](#) on page 72
  - ["FFT Spectral Leakage"](#) on page 73
  - ["Units for Math Waveforms"](#) on page 78

## Filters Math Functions

You can use math filters to create a waveform that is the result of a the filter on an analog input channel or on the result of an arithmetic operation.

- ["Averaged Value"](#) on page 90
- ["Band Pass Filter"](#) on page 91
- ["Envelope"](#) on page 91
- ["High Pass and Low Pass Filter"](#) on page 92
- ["Smoothing"](#) on page 92

### Averaged Value

When the **Averaged Value** operator is selected, the math waveform becomes the selected source waveform, averaged the selected number of times.

The source waveform can be one of the analog input channels or one of the previous math function waveforms.

Unlike acquisition averaging, the math averaging operator can be used to average the data on a single analog input channel or math function.

If acquisition averaging is also used, the analog input channel data is averaged and the math function averages it again. You can use both types of averaging to get a certain number of averages on all waveforms and an increased number of averages on a particular waveform.

As with acquisition averaging, averages are calculated using a "decaying average" approximation, where:

$$\text{next\_average} = \text{current\_average} + (\text{new\_data} - \text{current\_average})/N$$

Where N starts at 1 for the first acquisition and increments for each following acquisition until it reaches the selected number of averages, where it holds.

Select **Reset Count** to clear the number of waveforms evaluated.

**See Also** · ["Averaging Acquisition Mode"](#) on page 169

## Band Pass Filter

The band-pass filter function applies the filter to the selected source waveform and displays the result in the math waveform.

Use the **Center** field to enter the center frequency of the band-pass filter.

Use the **Width** field to enter the frequency width of the band-pass filter. This specifies the filter's -3 dB cutoff frequencies (center frequency minus half the width and center frequency plus half the width).

### NOTE

The ratio of the input signal's Nyquist frequency and the selected -3 dB cutoff frequencies affects how many points are available in the output, and under some circumstances, there are no points in the output waveform.

## Envelope

The resulting math waveform shows the amplitude envelope for an amplitude modulated (AM) input signal.

This function uses a Hilbert transform to get the real (in-phase, I) and imaginary (quadrature, Q) parts of the input signal and then performs a square root of the sum of the real and imaginary parts to get the demodulated amplitude envelope waveform.

## High Pass and Low Pass Filter

The high-pass or low-pass filter functions apply the filter to the selected source waveform and display the result in the math waveform.

The high-pass filter is a single-pole high-pass filter.

The low-pass filter is a 4th order Bessel-Thompson filter.

Use the **Bandwidth** field to select the filter's -3 dB cutoff frequency.

### NOTE

The ratio of the input signal's Nyquist frequency and the selected -3 dB cutoff frequency affects how many points are available in the output, and under some circumstances, there are no points in the output waveform.



**Figure 16** Example of Low Pass Filter

## Smoothing

The resulting math waveform is the selected source with a normalized rectangular (boxcar) FIR filter applied.

The boxcar filter is a moving average of adjacent waveform points, where the number of adjacent points is specified by the **Smoothing Points** field. You can choose an odd number of points, from 3 up to half of the analysis record.

The smoothing operator limits the bandwidth of the source waveform. The smoothing operator can be used, for example, to smooth measurement trend waveforms.

## Visualizations Math Functions

You can apply visualization math functions that give you different ways of viewing captured data and measurement values.

- **"Magnify"** on page 93
- **"Max/Min Hold"** on page 94
- **"Maximum/Minimum"** on page 94
- **"Measurement Trend"** on page 94

### Magnify

The magnify math function lets you display an existing input source at different vertical settings to provide more vertical detail.



**Figure 17** Example of Magnify

See Also • **"Ax + B"** on page 81

## Max/Min Hold

The **Max Hold** operator records the maximum vertical values found at each horizontal bucket across multiple analysis cycles and uses those values to build a waveform.

The **Min Hold** operator is the same, except it records the minimum vertical values.

When not used in a frequency analysis domain, these functions are often referred to as **Max Envelope** and **Min Envelope**.

Select **Reset Count** to clear the number of waveforms evaluated.

## Maximum/Minimum

The **Maximum** operator is like the **Max Hold** operator without the hold. The maximum vertical values found at each horizontal bucket are used to build a waveform.

The **Minimum** operator is like the **Min Hold** operator without the hold. The minimum vertical values found at each horizontal bucket are used to build a waveform.

## Measurement Trend

The measurement trend math function shows measurement values for a waveform (based on measurement threshold settings) as the waveform progresses across the screen. For every cycle, a measurement is made, and the value is displayed on the screen for the cycle.



**Figure 18** Example of Measurement Trend

Use the **Measurement** drop-down list to select the previously added measurement whose trend you want to look at. You can display trend values for these measurements:

- Average
- RMS - AC
- Ratio
- Period
- Frequency
- +Width
- -Width
- +Duty Cycle
- -Duty Cycle
- Rise Time
- Fall Time

Select **Thresholds...** to open the Measurement Thresholds dialog box where you can set up measurement thresholds for analog channels, math functions, and reference waveforms.

If a measurement cannot be made for part of a waveform, the trend function output is a hole (that is, no value) until a measurement can be made.

## The Analysis Record and Waveform Math

Keysight InfiniiVision oscilloscopes are designed to provide high *waveform update rates* which give you an increased probability of capturing infrequent events. With high waveform update rates, there is less "*dead time*" between acquisitions.

To provide high waveform update rates, there are some things the oscilloscope does with memory:

- When running, acquisition memory is split into two memories so that the processing of one acquisition can take place while another acquisition is being captured. For single acquisitions, the full memory is used. Waveform data in acquisition memory is called the *raw acquisition record*.
- There is a separate *eavesdrop memory* used for making measurements and for calculating math functions. Data in this memory is a reduced-sample decimation of the data in the raw acquisition record. Waveform data in eavesdrop memory is called the *analysis record*.

The default length of the analysis record is 64K points. To improve the precision of measurements and math functions (including FFT), at the expense of waveform update rate, you can also select deeper analysis record lengths.

(If you want to calculate math functions on a longer record, you can save the raw acquisition record and use programs like Excel or MATLAB to perform the analysis.)

Waveform data for the acquisition time (that is, the time per division setting multiplied by 10 divisions across the display) is saved to the memories. When the oscilloscope analog-to-digital converter's (ADC, or digitizer) sample period yields more data points than can be stored in the memory, some samples are thrown away (decimated), and the effective (or actual) sample rate is reduced. This is why, at greater time/div settings, the displayed sample rate decreases.

For example, suppose an oscilloscope's digitizer has a sample period of 1 ns (maximum sample rate of 1 GSa/s) and a 1 M memory depth. At that rate, memory is filled in 1 ms. If the acquisition time is 100 ms (10 ms/div), only 1 of every 100 samples is needed to fill memory. The effective sample rate becomes 10 MSa/s.

The decimator is configured to provide a best-estimate of all the samples that each point in the record represents. There is no filtering in the decimation.

#### FFT (Spectral) Analysis of Analysis Record Data

When the FFT operator is turned on, the decimation from the raw acquisition record to the analysis record works on integer rate down-sampling. For example, a raw acquisition record of 20M points and an analysis record of 64K points are already set up with an integer rate decimation of 320 (20M/320 = 64K).

For FFT analysis, the decimated record is then zero-padded to  $2^{(X+1)}$  where  $2^X \geq$  record length. For the above example, the power of 2 greater than the record length is 65536, so the record is zero-padded to 131072 points.

You can look at the FFT math function results on the oscilloscope to work backward and find the un-zero-padded decimated record length as well as the FFT length used after the zero-padding:

- First, we know:
  - The FFT algorithm translates a time record of N equally spaced samples into N/2 equally spaced lines in the frequency domain.
  - The width of the FFT on the display is the maximum frequency in the FFT. The maximum FFT frequency is also  $f_S/2$ , where  $f_S$  is the effective sample rate of the decimated data. (Use the center/span or start/stop frequency controls to display the maximum FFT frequency.)
  - The FFT Resolution is displayed in the FFT menu. FFT resolution is also known as the FFT bin width or a line in the frequency domain.
- Therefore, the un-zero-padded decimated record length is:  $f_S \times$  the acquisition time (or  $2 \times$  max FFT freq  $\times$  acquisition time).
- Also, the FFT length used after the zero-padding is:  $2 \times$  (maximum FFT frequency)/(FFT Resolution).

All this works the same with analysis records greater than the 64K-point default.

For more information on FFT transformation, see Keysight Application Note 243, *The Fundamentals of Signal Analysis* at <http://literature.cdn.keysight.com/litweb/pdf/5952-8898E.pdf>.



## 6 Reference Waveforms

To save a waveform to a reference waveform location / 99

To display a reference waveform / 100

To scale and position reference waveforms / 100

To adjust reference waveform skew / 101

To display reference waveform summary information / 101

To save/recall reference waveform files to/from a USB storage device / 101

Analog channel or math waveforms can be saved to one of two reference waveform locations in the oscilloscope. Then, a reference waveform can be displayed and compared with other waveforms.

You can adjust the scale, position, and skew of reference waveforms, and you can display summary information for all reference waveforms.

Analog channel, math, or reference waveforms can be saved to a reference waveform file on a USB storage device. You can recall a reference waveform file from a USB storage device into one of the reference waveform locations.

### To save a waveform to a reference waveform location

- 1 From the menu, choose **Sources > Reference Waveforms...**

The Reference Waveform dialog box has tabs for the two available reference waveforms, R1 and R2.

- 2 In the tab for the reference waveform location you want to use, select the **Source** you want to save.

- 3 Select **Save to R1/R2** to save the waveform to the reference waveform location.

**On** is automatically selected and the reference waveform is displayed.

#### NOTE

Reference waveforms are non-volatile – they remain after power cycling or performing a default setup.

- To clear a reference waveform location
- 1 From the menu, choose **Sources > Reference Waveforms....**
  - 2 In the Reference Waveform dialog box tab for the location you want to clear, select **Clear R1/R2** to clear the reference waveform location.

Reference waveforms are also cleared by a Factory Default or Secure Erase (see [Chapter 21](#), “Save/Email/Recall (Setups, Screens, Data),” starting on page 261).

## To display a reference waveform

- 1 From the menu, choose **Sources > Reference Waveforms....**
- 2 In the Reference Waveform dialog box tab for the waveform you want to display, select **On** to enable/disable the reference waveform display.



See Also · ["To display reference waveform summary information"](#) on page 101

## To scale and position reference waveforms

- 1 From the menu, choose **Sources > Reference Waveforms....**
- 2 In the Reference Waveform dialog box tab for the waveform you want to scale or position, use the **Scale** and **Offset** controls.

## To adjust reference waveform skew

You can adjust the horizontal skew of reference waveforms.

- 1 From the menu, choose **Sources > Reference Waveforms...**
- 2 In the Reference Waveform dialog box tab for the waveform whose skew you want to adjust, use the **Skew** field to enter the value.

## To display reference waveform summary information

- 1 From the menu, choose **Sources > Reference Waveforms...**
- 2 In the Reference Waveform dialog box, select **Reference Summary...**

The Reference Summary dialog box opens and displays the **Scale**, **Offset**, and **Skew** values for all reference waveforms.

You can use the values fields to make adjustments to the values.

## To save/recall reference waveform files to/from a USB storage device

Analog channel, math, or reference waveforms can be saved to a reference waveform file on a USB storage device. See "[To save reference waveform files to a USB storage device](#)" on page 266.

You can recall a reference waveform file from a USB storage device into one of the reference waveform locations. See "[To recall reference waveform files from a USB storage device](#)" on page 270.



# 7 Digital Channels

- To connect the digital probes to the device under test / 103
- Acquiring waveforms using the digital channels / 106
- To display digital channels using Autoscale / 106
- Interpreting the digital waveform display / 107
- To change the displayed size of the digital channels / 108
- To switch a single channel on or off / 109
- To switch multiple digital channels on or off / 109
- To reposition a digital channel / 109
- To change the logic threshold for digital channels / 110
- To display digital channels as a bus / 110
- Digital channel signal fidelity: Probe impedance and grounding / 113

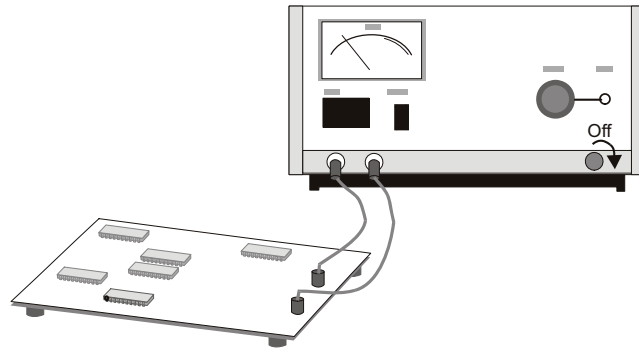
This chapter describes how to use the digital channels of a mixed-signal oscilloscope (MSO).

The digital channels are enabled on all HD3-Series models. The digital channels probe cable is an orderable option.

## To connect the digital probes to the device under test

- 1** If necessary, turn off the power supply to the device under test.

Turning off power to the device under test would only prevent damage that might occur if you accidentally short two lines together while connecting probes. You can leave the oscilloscope powered on because no voltage appears at the probes.



- 2 Connect the digital probe cable to the DIGITAL Dn - D0 connector on the mixed-signal oscilloscope. The digital probe cable is keyed so you can connect it only one way. You do not need to power-off the oscilloscope.

**CAUTION**

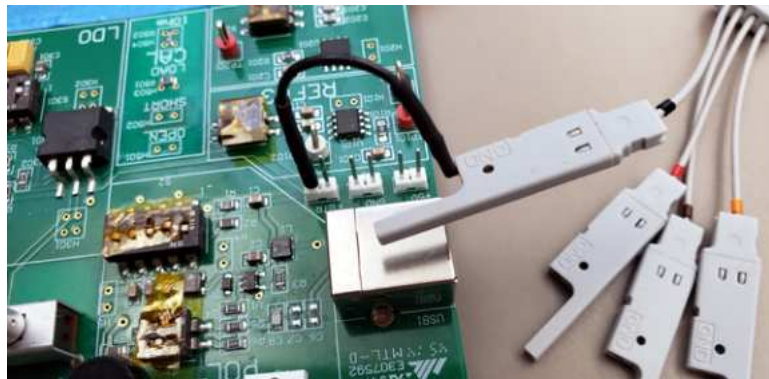
**⚠ Probe cable for digital channels**

Use only the Keysight logic probe and accessory kit supplied with the mixed-signal oscilloscope.



The MSO cable operating temperature range is 0 °C to 55 °C, and its non-operating (storage) temperature range is -40 °C to 70 °C.

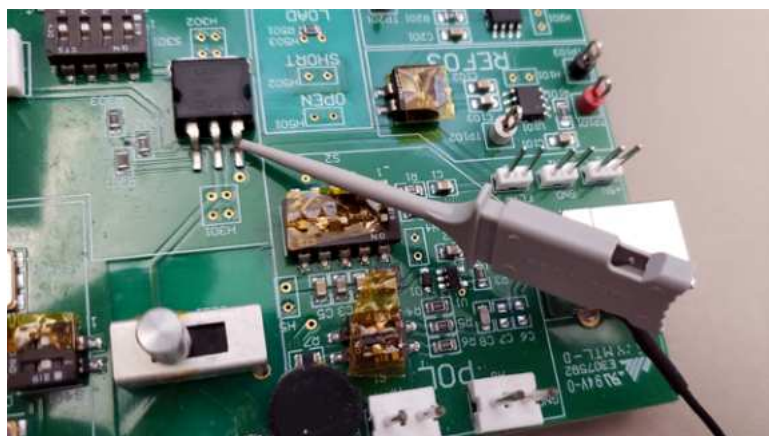
- 3 Connect the ground lead on each set of channels (each pod), using a probe grabber. The ground lead improves signal fidelity to the oscilloscope, ensuring accurate measurements.



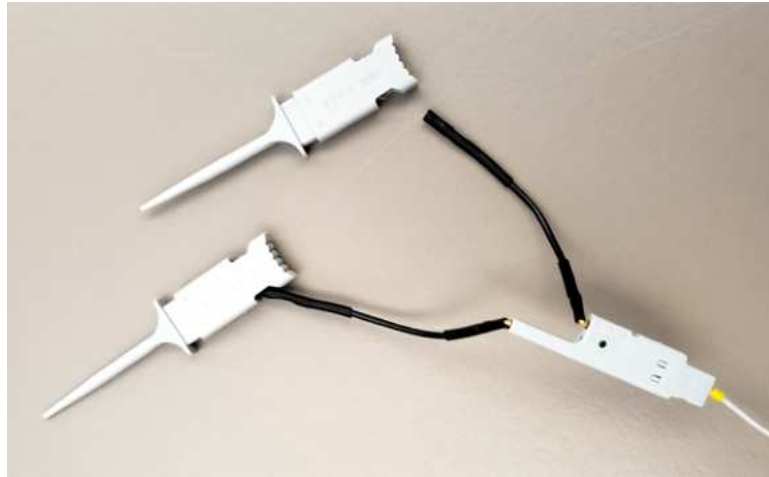
- 4 Connect a grabber to one of the probe leads. (Other probe leads are omitted from the figure for clarity.)



- 5 Connect the grabber to a node in the circuit you want to test.



- 6 For high-speed signals, connect a ground lead to the probe lead, connect a grabber to the ground lead, and attach the grabber to ground in the device under test.



- 7 Repeat these steps until you have connected all points of interest.

## Acquiring waveforms using the digital channels

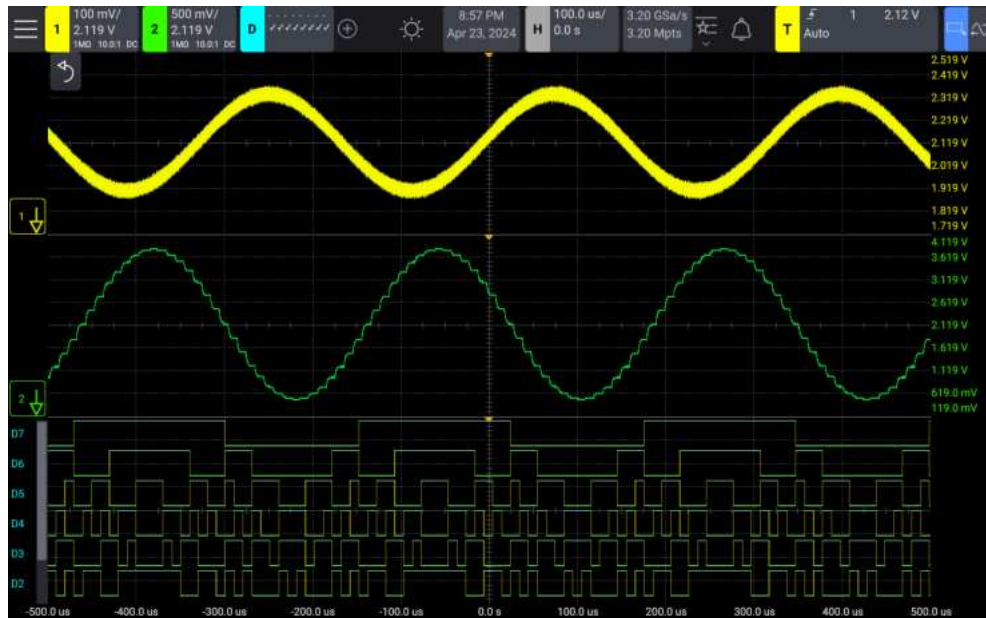
When you press **[Run/Stop]** or **[Single]** to run the oscilloscope, the oscilloscope examines the input voltage at each input probe. When the trigger conditions are met the oscilloscope triggers and displays the acquisition.

For digital channels, each time the oscilloscope takes a sample it compares the input voltage to the logic threshold. If the voltage is above the threshold, the oscilloscope stores a 1 in sample memory; otherwise, it stores a 0.

## To display digital channels using Autoscale

When signals are connected to the digital channels – be sure to connect the ground leads – Autoscale quickly configures and displays the digital channels.

- To configure the instrument quickly, press the **[Auto Scale]** key.



**Figure 19** Example: Autoscale of digital channels

Any digital channel with an active signal will be displayed. Any digital channels without active signals will be turned off.

- If you want to return to the oscilloscope settings that existed before, select the



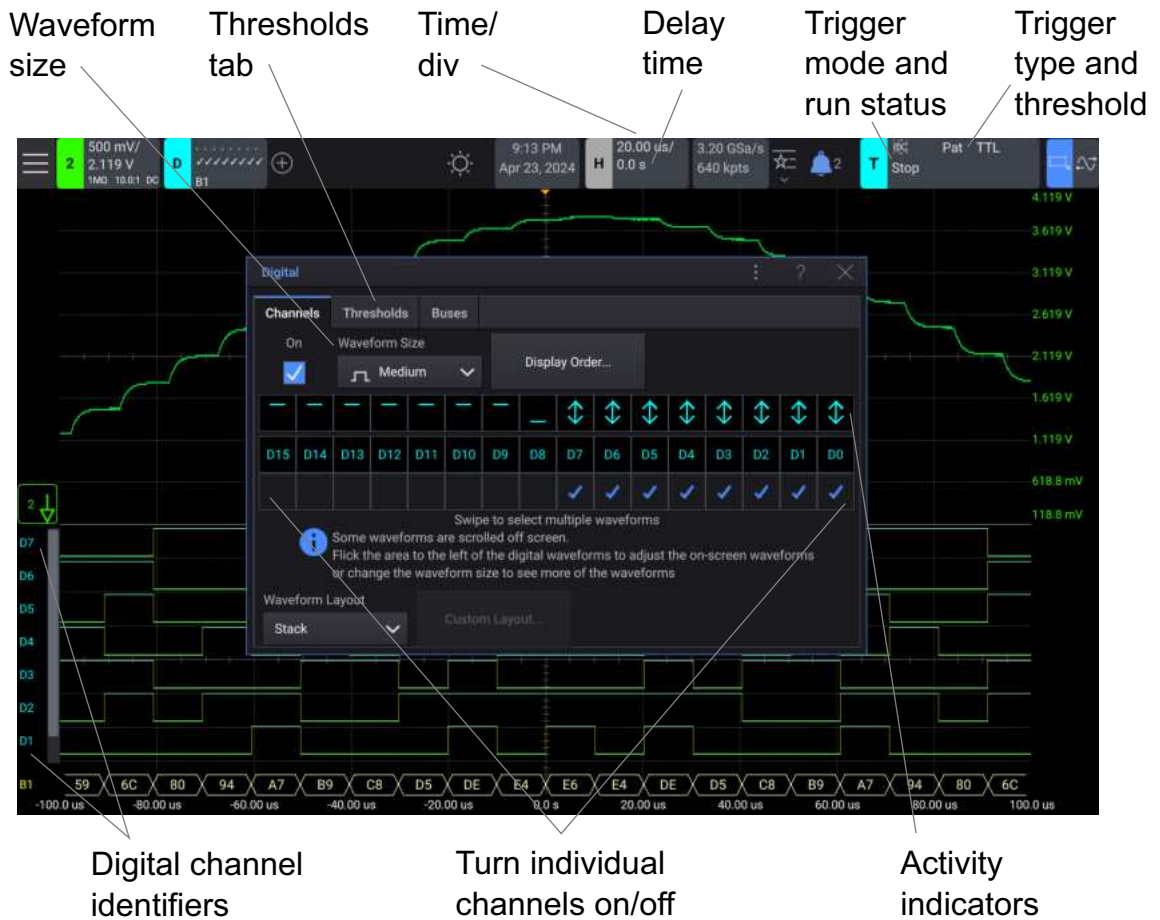
Undo button.

This is useful if you have unintentionally pressed the **[Auto Scale]** key or do not like the settings Autoscale has selected. This will return the oscilloscope to its previous settings. See also: "[How Autoscale Works](#)" on page 28.

To set the instrument to the factory-default configuration, press the **[Default Setup]** key.

## Interpreting the digital waveform display

The following figure shows the Digital dialog box (select the digital channels badge or choose **Sources > Digital Channels...**) and displayed digital channels.



**Activity indicator** When any digital channels are turned on, an activity indicator is displayed in the status line at the bottom of the display. A digital channel can be always high (■), always low (■), or actively toggling logic states (↑↓).

## To change the displayed size of the digital channels

- 1 Open the Digital dialog box by selecting the digital channels badge or by choosing **Sources > Digital Channels...**
- 2 In the Channels tab, use the **Waveform Size** drop-down list to select the size of displayed digital channels.

The sizing control lets you spread out or compress the digital traces vertically on the display for more convenient viewing.

## To switch a single channel on or off

- 1 Open the Digital dialog box by selecting the digital channels badge or by choosing **Sources > Digital Channels...**
- 2 In the Channels tab, select an individual digital channel cell to toggle its display.

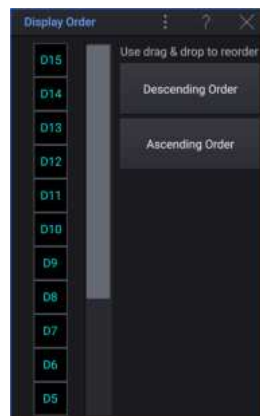
## To switch multiple digital channels on or off

- 1 Open the Digital dialog box by selecting the digital channels badge or by choosing **Sources > Digital Channels...**
- 2 In the Channels tab, swipe multiple digital channel cells to toggle their selection.

If you want to switch the digital channels off, clear the **On** check box or press **[Digital]** key.

## To reposition a digital channel

- 1 Open the Digital dialog box by selecting the digital channels badge or by choosing **Sources > Digital Channels...**
- 2 In the Channels tab, select **Display Order...**
- 3 In the Display Order dialog box:



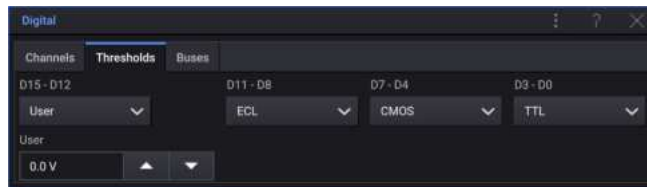
You can:

- Drag a digital channel to a new position in the list. The order in the list is the same that appears in the waveform grid.

- Select **Descending Order** to reorder all channels from higher numbered channels to lower numbered channels.
- Select **Ascending Order** to reorder all channels from lower numbered channels to higher numbered channels.

## To change the logic threshold for digital channels

- 1 Open the Digital dialog box by selecting the digital channels badge or by choosing **Sources > Digital Channels...**
- 2 In the Thresholds tab:



Use the **D15 - D12**, **D11 - D8**, **D7 - D4**, and **D3 - D0** drop-down lists to select a logic family preset or select **User** to define your own threshold.

Logic family	Threshold Voltage
<b>TTL</b>	+1.4 V
<b>CMOS</b>	+2.5 V
<b>ECL</b>	-1.3 V
<b>User</b>	Variable from -8 V to +8 V

The threshold you select applies to all channels within the selected D15 - D12, D11 - D8, D7 - D4, or D3 - D0 group. Each channel group can be set to a different threshold if desired.

Values greater than the set threshold are high (1) and values less than the set threshold are low (0).

## To display digital channels as a bus

Digital channels may be grouped and displayed as a bus, with each bus value displayed at the bottom of the display in hex or binary. You can create up to two buses.

To configure and display each bus:

- 1 Open the Digital dialog box by selecting the digital channels badge or by choosing **Sources > Digital Channels...**
- 2 In the Buses tab, select **Bus1** or **Bus2** to enable or disable the bus display.
- 3 In the drop-down list for a bus, select the **Hex** or **Binary** display format.
- 4 Select the channels in a bus by selecting or swiping cells.

The buses are shown at the bottom of the display.

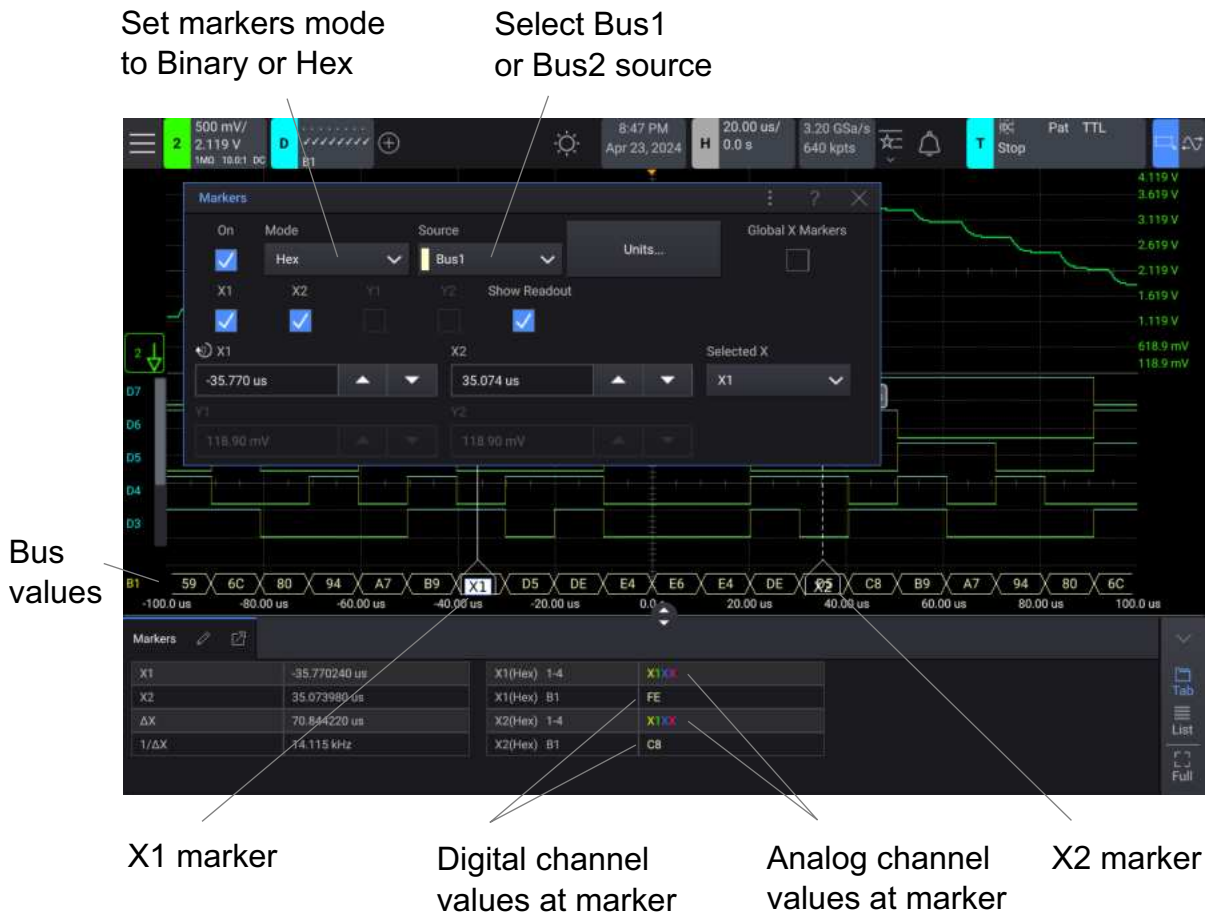


If the bus display is blank, completely white, or if the display includes "...", you need to expand the horizontal scale to allow space for the data to be shown, or you can use the markers to display the values (see ["Using markers to read bus values"](#) on page 111).

#### Using markers to read bus values

To read the digital bus value at any point using the markers:

- 1 Choose **Measure > Markers...** from the main menu.
- 2 In the Markers dialog box, select **On** to enable markers.
- 3 From the **Mode** drop-down list, select **Binary** or **Hex**.
- 4 From the **Source** drop-down list, select **Bus1** or **Bus2**.
- 5 Position the **X1** and **X2** markers to where you want to read the bus values (see ["To make marker measurements"](#) on page 178).



Bus values are displayed when using Pattern trigger

The bus values are also displayed when using the Pattern trigger function. Press the **[Pattern]** key on the front panel to display the Pattern Trigger Menu and the bus values will be displayed on the right, above the softkeys.

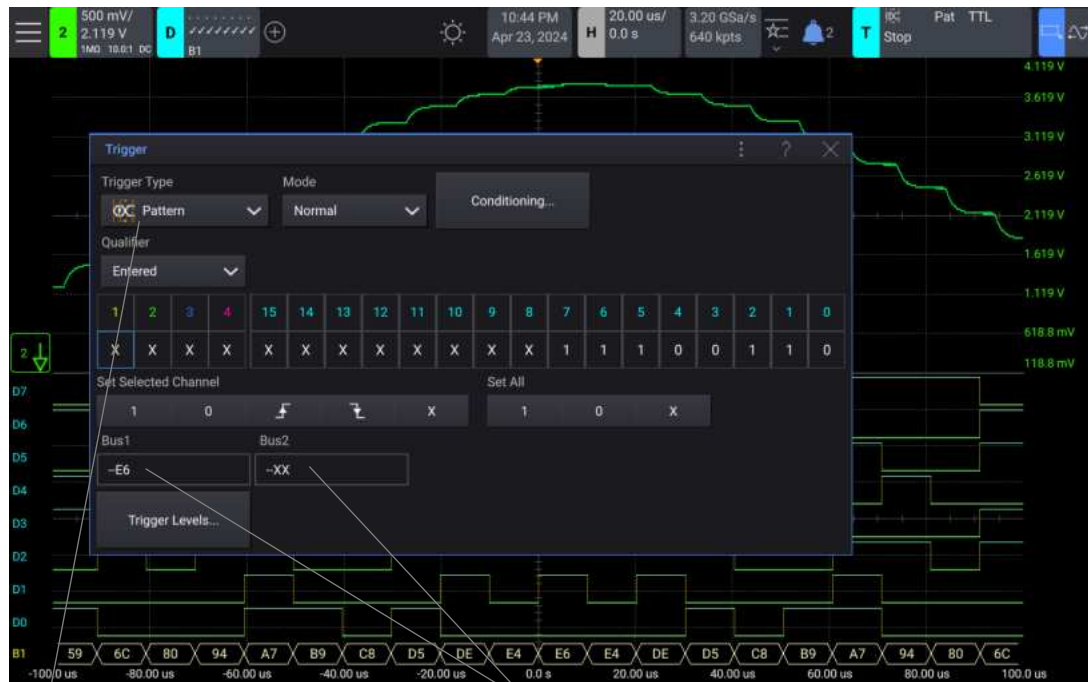
- 1 Open the Trigger dialog box by selecting the trigger badge or by choosing **Trigger > Setup...** from the main menu.
- 2 In the **Trigger Type** drop-down list, select **Pattern**.
- 3 Select the **Pattern** trigger type and the **Entered** qualifier.
- 4 In the **Bus1** or **Bus2** fields, enter the hex character values.

**NOTE**

If a digit is made up of less than four bits, the value of the digit is limited to the greatest number that can be represented by the number of bits.

The dollar sign (\$) will be displayed in the bus value when the bus value cannot be displayed as a hex value. This occurs when one or more "don't cares" (X) are combined with low (0) and high (1) logic levels in the pattern specification, or

when a transition indicator – rising edge ( $\uparrow$ ) or falling edge ( $\downarrow$ ) – are included in the pattern specification. A byte that consists of all don't cares (X) will be displayed in the bus as a don't care (X).



Pattern trigger  
definition

Trigger on  
bus values

See "[Pattern Trigger](#)" on page 141 for more information on Pattern triggering.

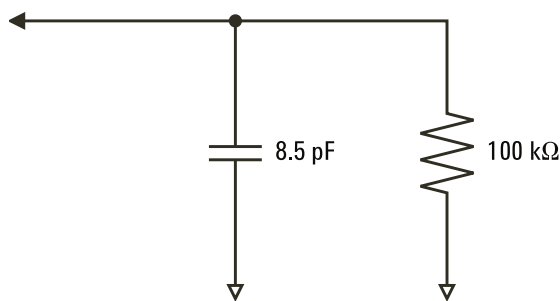
## Digital channel signal fidelity: Probe impedance and grounding

When using the mixed-signal oscilloscope you may encounter problems that are related to probing. These problems fall into two categories: probe loading and probe grounding. Probe loading problems generally affect the device under test, while probe grounding problems affect the accuracy of the data to the measurement instrument. The design of the probes minimizes the first problem, while the second is easily addressed by good probing practices.

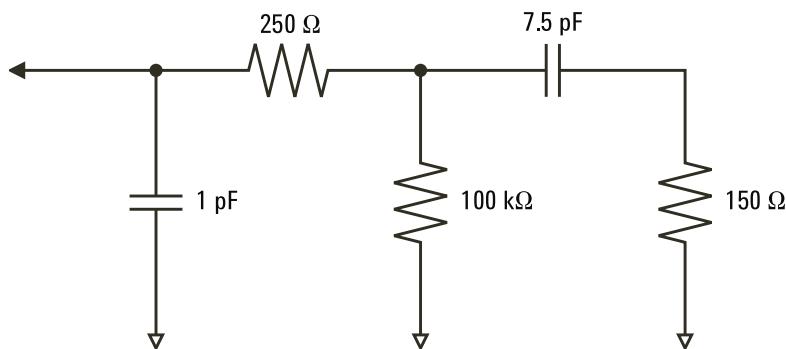
### Input Impedance

The logic probes are passive probes, which offer high input impedance and high bandwidths. They usually provide some attenuation of the signal to the oscilloscope, typically 20 dB.

Passive probe input impedance is generally specified in terms of a parallel capacitance and resistance. The resistance is the sum of the tip resistor value and the input resistance of the test instrument (see the following figure). The capacitance is the series combination of the tip compensating capacitor and the cable, plus instrument capacitance in parallel with the stray tip capacitance to ground. While this results in an input impedance specification that is an accurate model for DC and low frequencies, the high-frequency model of the probe input is more useful (see the following figure). This high-frequency model takes into account pure tip capacitance to ground as well as series tip resistance, and the cable's characteristic impedance ( $Z_0$ ).

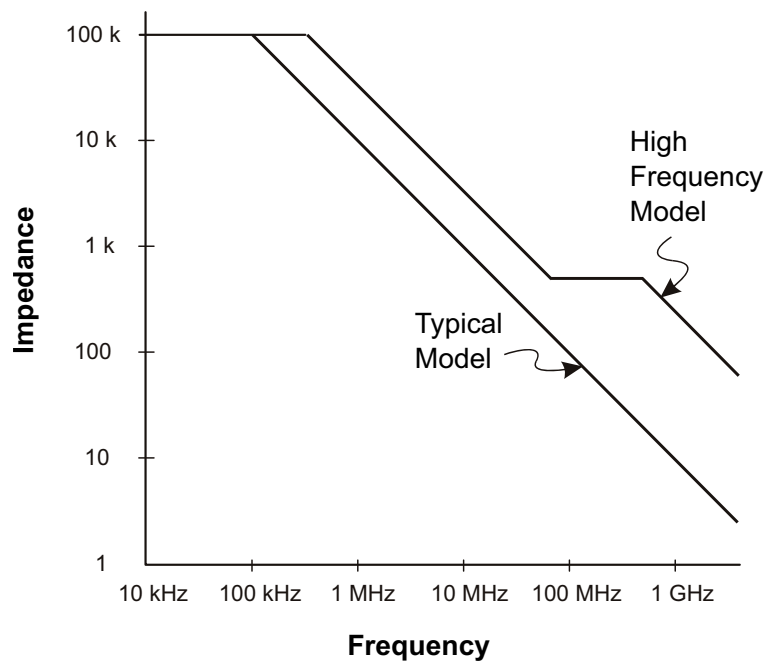


**Figure 20** DC and Low-Frequency Probe Equivalent Circuit



**Figure 21** High-Frequency Probe Equivalent Circuit

The impedance plots for the two models are shown in these figures. By comparing the two plots, you can see that both the series tip resistor and the cable's characteristic impedance extend the input impedance significantly. The stray tip capacitance, which is generally small (1 pF), sets the final break point on the impedance chart.



**Figure 22** Impedance versus Frequency for Both Probe Circuit Models

The logic probes are represented by the high-frequency circuit model shown above. They are designed to provide as much series tip resistance as possible. Stray tip capacitance to ground is minimized by the proper mechanical design of the probe tip assembly. This provides the maximum input impedance at high frequencies.

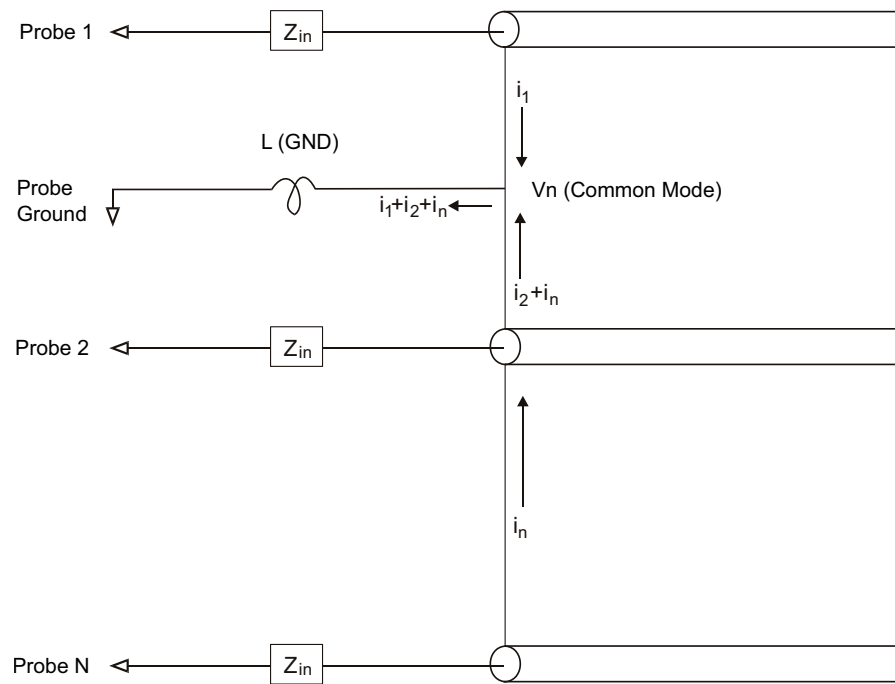
## Probe Grounding

A probe ground is the low-impedance path for current to return to the source from the probe. Increased length in this path will, at high frequencies, create large common mode voltages at the probe input. The voltage generated behaves as if this path were an inductor according to the equation:

$$V = L \frac{di}{dt}$$

Increasing the ground inductance (L), increasing the current (di) or decreasing the transition time (dt), will all result in increasing the voltage (V). When this voltage exceeds the threshold voltage defined in the oscilloscope, a false data measurement will occur.

Sharing one probe ground with many probes forces all the current that flows into each probe to return through the same common ground inductance of the probe whose ground return is used. The result is increased current ( $di$ ) in the above equation, and, depending on the transition time ( $dt$ ), the common mode voltage may increase to a level that causes false data generation.



**Figure 23** Common Mode Input Voltage Model

In addition to the common mode voltage, longer ground returns also degrade the pulse fidelity of the probe system. Rise time is increased, and ringing, due to the undamped LC circuit at the input of the probe, is also increased. Because the digital channels display reconstructed waveforms, they do not show ringing and perturbations. You will not find ground problems through examination of the waveform display. In fact, it is likely you will discover the problem through random glitches or inconsistent data measurements. Use the analog channels to view ringing and perturbations.

## Best Probing Practices

Because of the variables  $L$ ,  $di$ , and  $dt$ , you may be unsure how much margin is available in your measurement setup. The following are guidelines for good probing practices:

- The ground lead from each digital channel group (D15–D8 and D7–D0) should be attached to the ground of the device under test if any channel within the group is being used for data capture.

- When capturing data in a noisy environment, every third digital channel probe's ground should be used in addition to the channel group's ground.
- High-speed timing measurements (rise time < 3 ns) should make use of each digital channel probe's own ground.

When designing a high-speed digital system, you should consider designing dedicated test ports that interface directly to the instrument's probe system. This will ease measurement setup and ensure a repeatable method for obtaining test data. The 01650-61607 16-channel logic probe cable and the 01650-63203 termination adapter are designed to make it easy to connect to industry-standard, 20-pin board connectors. The cable is a 2 m logic analyzer probe cable, and the termination adapter provides the proper RC networks in a very convenient package. These parts, as well as the 1251-8106 20-pin, low-profile, straight board connector, can be ordered from Keysight Technologies.



# 8 Protocol Decode

Protocol Decode Options / 119

Protocol Listing / 120

Searching Lister Data / 121

Protocol decode lets you trigger on and display decoded serial bus data in many protocols. As with other InfiniiVision oscilloscopes, serial decodes are hardware-accelerated for fast performance.

## Triggering on Protocol Data

In some cases, such as when triggering on a slow serial signal (for example, I2C, SPI, CAN, LIN, etc.) it may be necessary to switch from the Auto trigger mode to the Trig'd trigger mode to prevent the oscilloscope from Auto-triggering and stabilize the display. You can select the trigger mode by pressing the **[Mode]** key.

Also, the threshold voltage level must be set appropriately for each source channel. The threshold level for each serial signal can be set in the Trigger Levels dialog box. From the menu, select **Trigger > Trigger Levels...**

## Protocol Decode Options

These license-enabled serial decode options are available:

Licensed Protocol Decode	See:
Automotive Serial Triggering and Analysis for HD3-Series	<ul style="list-style-type: none"><li>▪ <b>Chapter 25</b>, "CAN Triggering and Protocol Decode," starting on page 319.</li><li>▪ <b>Chapter 27</b>, "LIN Triggering and Protocol Decode," starting on page 339.</li></ul>
Embedded Serial Triggering and Analysis for HD3-Series	<ul style="list-style-type: none"><li>▪ <b>Chapter 26</b>, "I2C Triggering and Protocol Decode," starting on page 331.</li><li>▪ <b>Chapter 28</b>, "SPI Triggering and Protocol Decode," starting on page 347.</li><li>▪ <b>Chapter 29</b>, "UART/RS232/422/485 Triggering and Protocol Decode," starting on page 355.</li></ul>

To determine whether these licenses are installed on your oscilloscope, see "[To display oscilloscope information](#)" on page 290.

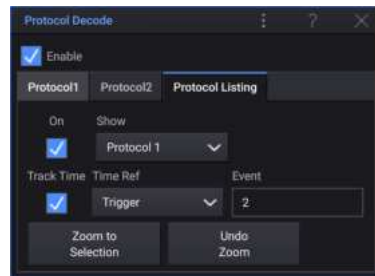
To order protocol triggering and decode licenses, go to [www.keysight.com](http://www.keysight.com) and search for the product number (see "[Licensed Options Available](#)" on page 308) or contact your local Keysight Technologies representative (see [www.keysight.com/find/contactus](http://www.keysight.com/find/contactus)).

## Protocol Listing

The Protocol Listing window is a powerful tool for investigating protocol failures. You can use the Protocol Listing window to view large amounts of packet level serial data in a tabular format, including time tags and specific decoded values.

To use the Protocol Listing window:

- 1 Set up trigger and decode on the serial data signals to be analyzed.
- 2 Press **[Protocol Decode]**.
- 3 In the Protocol Decode dialog box, select the **Protocol Listing** tab.
- 4 In the Protocol Listing tab, select **On**.



When multiple protocol decodes are enabled, the **Show** option selects the one displayed in the Protocol Listing window.

In the Protocol Listing tab, you can also:

- Enable or disable the **Track Time** option. When enabled, as you select different Lister rows, the horizontal delay changes to the Time of the selected row. Also, changing the horizontal delay will scroll the Lister.
  - Use the **Time Ref** drop-down list to select whether the Time column in the Lister display shows times relative to the **Trigger** or relative to the **Previous Row**.
- 5 Before you can select a row or navigate through the Protocol Listing data, oscilloscope acquisitions must be stopped.

Press the **[Single]** key to stop the acquisition.

Pressing **[Single]** instead of **[Stop]** fills the maximum memory depth.

When zoomed out and viewing a large number of packets, the Protocol Listing may not be able to display information for all packets. However, when you press the **[Single]** key the Protocol Listing will contain all on-screen serial decode information.

- 6 When acquisitions are stopped, you can use the **Event** field to select a Protocol Listing row (or if the row is displayed, you can directly select it), and then select **Zoom to Selection** to center the waveform display and zoom the horizontal scale to the selected Protocol Listing row.
- 7 Select **Undo Zoom** to return to the horizontal scale and delay (position) settings before the last **Zoom to Selection**.

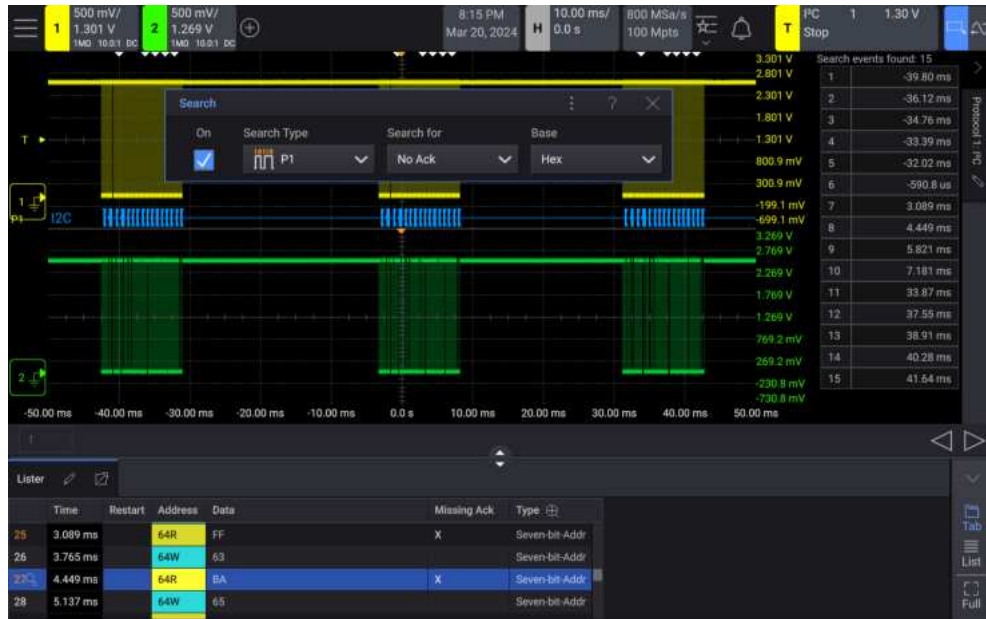


## Searching Lister Data

When protocol decode is enabled, you can use the Search feature to find and place marks on rows in the Lister.

The Search dialog box lets you specify events to find. It is similar to specifying protocol triggers.

Events found are marked in orange in the far left Lister column. The total number of events found is displayed with the **Search events found** table title.



Each serial decode option lets you find protocol-specific headers, data, errors, etc. See:

- ["Searching for CAN Data in the Lister"](#) on page 328
- ["Searching for I2C Data in the Lister"](#) on page 337
- ["Searching for LIN Data in the Lister"](#) on page 345
- ["Searching for SPI Data in the Lister"](#) on page 352
- ["Searching for UART/RS232/422/485 Data in the Lister"](#) on page 361

## 9 Display Settings

To change the waveform layout / 123

To set or clear persistence / 124

To clear the display / 126

To select the grid options / 126

To adjust the grid intensity / 127

To display and edit waveform labels / 127

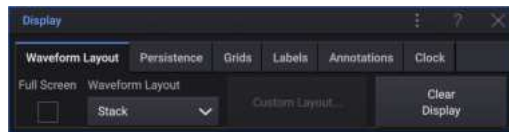
To add an annotation / 130

To adjust waveform intensity / 132

See Also • **"Setting the Oscilloscope's Clock"** on page 281

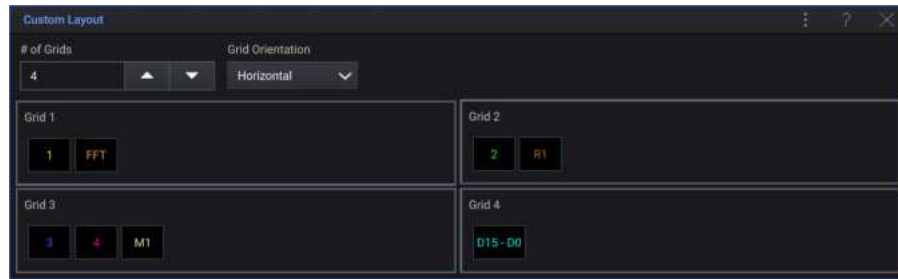
### To change the waveform layout

- 1 From the menu, choose **Setup > Display...**
- 2 In the Display dialog box, select the **Waveform Layout** tab.




- 3 Select the **Waveform Layout** drop-down list, and select between:
  - **Stack Waveforms Vertically** – Waveforms appear in individual grids that are vertically stacked.
  - **Tile Waveforms Horizontally** – Waveforms appear in individual grids that are horizontally tiled and perhaps vertically stacked, depending on the number of waveforms that are displayed.
  - **Overlay Waveforms** – Waveforms are overlaid in one grid.
  - **Custom Layout** – Lets you specify the number of grids, their orientation, and which waveforms appear in which grid.

Select **Custom Layout...** to open the Custom Layout dialog box:



- **# of Grids** – Lets you select from one to four grids.
  - **Grid Orientation** – You can choose from:
    - **Vertical** – Vertically stacked grids.
    - **Horizontal** – Horizontally tiled and perhaps vertically stacked grids, depending on the number of grids.
  - **Grid 1-4** – These boxes are oriented as specified. You can drag waveforms to whichever grid box you like.
- 4 The **Waveform Layout** tab (in the Display dialog box) also lets you:
- Select **Full Screen** to make the waveform grid(s) take up the whole screen.
  - Select **Clear Display** to clear acquisition data from the oscilloscope display. This is the same as pressing the front panel **[Clear Display]** key.

You can also specify the waveform layout in the Quick Selection dialog box (select  or choose **Sources > Quick Selection...** from the main menu).

For examples of different waveform layouts, see "**Lay Out Waveform Grids**" on page 37.

## To set or clear persistence

With persistence, the oscilloscope updates the display with new acquisitions, but does not immediately erase the results of previous acquisitions. All previous acquisitions are displayed with reduced intensity. New acquisitions are shown in their normal color with normal intensity.

Waveform persistence is kept only for the current display area; you cannot pan and zoom the persistence display.

To use persistence:

- 1 From the menu, choose **Setup > Display...**
- 2 In the Display dialog box, select the **Persistence** tab.



**3** Select the **Persistence** field, and select between:

- **Off** – Turns off persistence.

When persistence is off, you can select **Capture Waveforms** to perform a single-shot infinite persistence. A single acquisition's data is displayed with reduced intensity, and it remains on the display until you clear persistence or clear the display.

Included in the persistence data are active analog channels and digital channels.

- $\infty$  Persistence – (infinite persistence) Results of previous acquisitions are never erased.

Use infinite persistence to measure noise and jitter, to see the worst-case extremes of varying waveforms, to look for timing violations, or to capture events that occur infrequently.

- **Variable Persistence** – Results of previous acquisitions are erased after a certain amount of time.

Variable persistence gives you a view of acquired data that is similar to analog oscilloscopes.

When variable persistence is selected, enter the amount of **Time** that previous acquisitions are to be displayed.

The display will begin accumulating multiple acquisitions.

When **Digital** is selected, persistence of digital channel waveforms is also displayed.

**4** To erase the results of previous acquisitions from the display, select **Clear Persistence**.

The oscilloscope will start to accumulate acquisitions again.

**5** To return the oscilloscope to the normal display mode, turn off persistence; then, select **Clear Persistence**.

Turning off persistence does not clear the display. The display is cleared if you select **Clear Display**, press the **[Clear Display]** key, or if you press the **[Auto Scale]** key (which also turns off persistence).

**NOTE**

Persistence is not available for math or FFT functions.

For another method of seeing worst-case extremes of varying waveforms, see "[Glitch or Narrow Pulse Capture](#)" on page 167.

## To clear the display

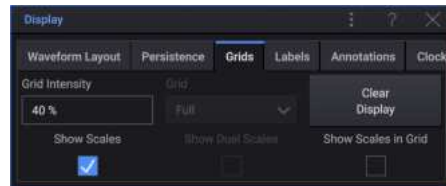
Do one of the following:

- Press the **[Clear Display]** key.
- From the menu, choose **Control > Clear Display**.
- From the menu, choose **Setup > Display....** In the Display dialog box's **Waveform Layout**, **Persistence**, or **Grids** tabs, select **Clear Display**.

You can also configure the **Setup > (Quick Action)** menu item to clear the display. See "[Configuring the \(Quick Action\) Menu Item](#)" on page 291.

## To select the grid options

- 1 From the menu, choose **Setup > Display....**
- 2 In the Display dialog box, select the **Grids** tab.



- 3 You can use the following controls:

- **Grid Intensity** – Enter a value from 0 to 100%.

Each major vertical division in the grid corresponds to the vertical sensitivity shown in the status line at the top of the display.

Each major horizontal division in the grid corresponds to the time/div shown in the status line at the top of the display.

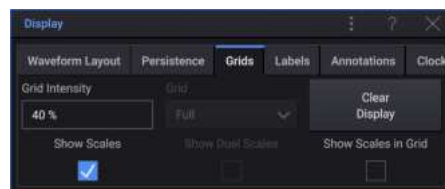
- **Grid** – This drop-down menu lets you select from these grid types:
  - **Full** – the normal oscilloscope grid.
- **Clear Display** – Clears acquisition data from the oscilloscope display. This is the same as pressing the front panel **[Clear Display]** key.
- **Show Scales** – When selected, grid value labels are shown along the grid's horizontal and vertical axes.

- **Show Dual Scales** – When multiple waveforms are displayed in a grid, you can enable dual vertical scales for the top two waveforms in the Z-order. Select the dual scales for a pop-up dialog box that lets you specify the waveform Z-order.
- **Show Scales in Grid** – You can show scales within the grid to make the grid areas a little larger. In this case, waveforms can be drawn over grid values at the right side and bottom of the grid.

## To adjust the grid intensity

To adjust the display grid (graticule) intensity:

- 1 From the menu, choose **Setup > Display...**
- 2 In the Display dialog box, select the **Grids** tab.



- 3 In the **Grid Intensity** field, enter a value from 0 to 100%.

Each major vertical division in the grid corresponds to the vertical sensitivity shown in the status line at the top of the display.

Each major horizontal division in the grid corresponds to the time/div shown in the status line at the top of the display.

## To display and edit waveform labels

You can define labels and assign them to analog input channels, math functions, reference waveforms, digital channels, and buses.

- **"To turn the label display on or off"** on page 128
- **"To assign a predefined label to a waveform"** on page 128
- **"To define a new label"** on page 128
- **"To load a list of labels from a text file you create"** on page 129
- **"To reset the label library to the factory default"** on page 130

To turn the label display on or off

- 1 From the menu, choose **Setup > Display...**
- 2 In the Display dialog box, select the **Labels** tab.



- 3 Select **On** to turn the labels on or off for the displayed waveforms.  
Labels are displayed at the left edge of the displayed traces.
- 4 To adjust the vertical Y position of the label with respect to the reference level, use the **Offset** field.

To assign a predefined label to a waveform

- 1 From the menu, choose **Setup > Display...**
- 2 In the Display dialog box, select the **Labels** tab.
- 3 Select the **Source** for label assignment.  
The waveform does not have to be turned on to have a label assigned to it.
- 4 From the **Library** drop-down list, select the predefined label.
- 5 Select **Apply New Label** to assign the label to the selected waveform.

To define a new label

- 1 From the menu, choose **Setup > Display...**
- 2 In the Display dialog box, select the **Labels** tab.
- 3 Select the **New Label** field.

- 4 In the Enter New Label dialog box, select keys to enter the text of the label:
  - When the front panel **[Touch]** key is lit, you can touch the screen to select.
  - If a USB mouse is connected, you can click to select.
  - If a USB keyboard is connected, you can type to enter text.

When you are done entering text, select **OK**.

- 5 The new label can be assigned to the selected **Source** and added to the library by selecting **Apply New Label**.

#### Label Assignment Auto-Increment

When you assign a label ending in a digit, such as ADDR0 or DATA0, the oscilloscope automatically increments the digit and displays the modified label in the "New Label" field after you select **Apply New Label**. Therefore, you only need to select a new **Source** and select **Apply New Label** again to assign the label to the waveform. Only the original label is saved in the label list. This feature makes it easier to assign successive labels to numbered control lines and data bus lines.

To load a list of labels from a text file you create

It may be convenient to create a list of labels using a text editor, then load the label list into the oscilloscope. The list can have up to 75 labels. When loaded, labels are added to the beginning of the oscilloscope's list. If more than 75 labels are loaded, only the first 75 are stored.

To load labels from a text file into the oscilloscope:

- 1 Use a text editor to create each label. Each label can be up to 32 characters in length. Separate each label with a line feed.
- 2 Name the file labellist.txt and save it on a USB mass storage device such as a thumb drive.
- 3 Load the list into the oscilloscope using the File Explorer (from the menu choose **File > File Explorer...**).

#### NOTE

#### Label List Management

When you select the **Library** drop-down list, you will see a list of the last 75 labels used. The list does not save duplicate labels. Labels can end in any number of trailing digits. As long as the base string is the same as an existing label in the library, the new label will not be put in the library. For example, if label A0 is in the library and you make a new label called A12345, the new label is not added to the library.

When you save a new user-defined label, the new label will replace the oldest label in the list. Oldest is defined as the longest time since the label was last assigned to a waveform. Any time you assign any label to a waveform, that label will move to the newest in the list. Thus, after you use the label list for a while, your labels will predominate, making it easier to customize the instrument display for your needs.

When you reset the label library list (see next topic), all of your custom labels will be deleted, and the label list will be returned to its factory configuration.

To reset the label library to the factory default

#### NOTE

Selecting **Reset Library** will remove all user-defined labels from the library and set the labels back to the factory default. Once deleted, these user-defined labels cannot be recovered.

- 1 From the menu, choose **Setup > Display...**
- 2 In the Display dialog box, select the **Labels** tab.
- 3 Select **Reset Library**.

This will delete all user-defined labels from the library and set the labels in the library back to the factory default. However, this does not default the labels currently assigned to the waveforms (those labels that appear in the waveform area).

#### NOTE

#### Defaulting labels without erasing the default library

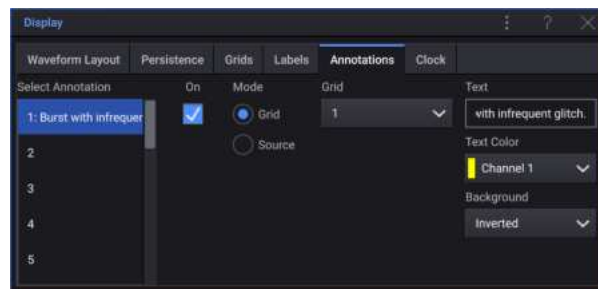
Pressing [**Default Setup**] sets all waveform labels back to the default labels but does not erase the list of user-defined labels in the library.

To add an annotation

You can add annotations to the oscilloscope's display. Annotations are useful for documentation purposes, to add notes before capturing screens.

To add an annotation:

- 1 From the menu, choose **Setup > Display...**
- 2 In the Display dialog box, select the **Annotations** tab.



- 3 In the Annotations tab, in the **Select Annotation** list, select the desired annotation.

You can define up to 20 annotations.

- 4 Select the **Text** field.

- 5 In the Enter Text dialog box, select keys to enter the text of the annotation:



- When the front panel **[Touch]** key is lit, you can touch the screen to select.
- If a USB mouse is connected, you can click to select.
- If a USB keyboard is connected, you can type to enter text.

When you are done entering text, select **OK**.

- 6 Select the annotation options:

- **Mode** – Specifies the selected annotation's assignment:
  - **Grid** – The annotation is assigned to a grid. Use the **Grid** drop-down menu to select the grid.

Use the **Text Color** drop-down menu to select the annotation's color. You can choose white, red, or colors that match analog channels, digital channels, math waveforms, reference waveforms, or markers (markers).

- **Source** – The annotation is assigned to a source waveform. Use the **Source** drop-down menu to select the source waveform.

The annotation's color matches the selected **Source** waveform.

- **Background** – Specify the annotation's background:
  - **Opaque** – The annotation has a solid background.
  - **Inverted** – The annotation's foreground and background colors are switched.
  - **Transparent** – The annotation has a transparent background.

- 7 Then, select **On** to enable/disable the annotation display.

When enabled, you can drag the annotation anywhere in the grid.



See Also · ["To save BMP or PNG image files"](#) on page 263

## To adjust waveform intensity

You can adjust the intensity of displayed waveforms to account for various signal characteristics, such as fast time/div settings and low trigger rates.

Increasing the intensity lets you see the maximum amount of noise and infrequently occurring events.

Reducing the intensity can expose more detail in complex signals as shown in the following figures.

- 1 From the menu, choose **Setup > Waveform Intensity...**
- 2 In the Intensity dialog box, to adjust the waveform intensity, either drag the slider, select the up or down buttons, or select the **Waveform Intensity** field to enter the percent value or turn the Entry knob.

Waveform intensity adjustment affects analog channel waveforms only (not math waveforms, reference waveforms, digital waveforms, etc.).

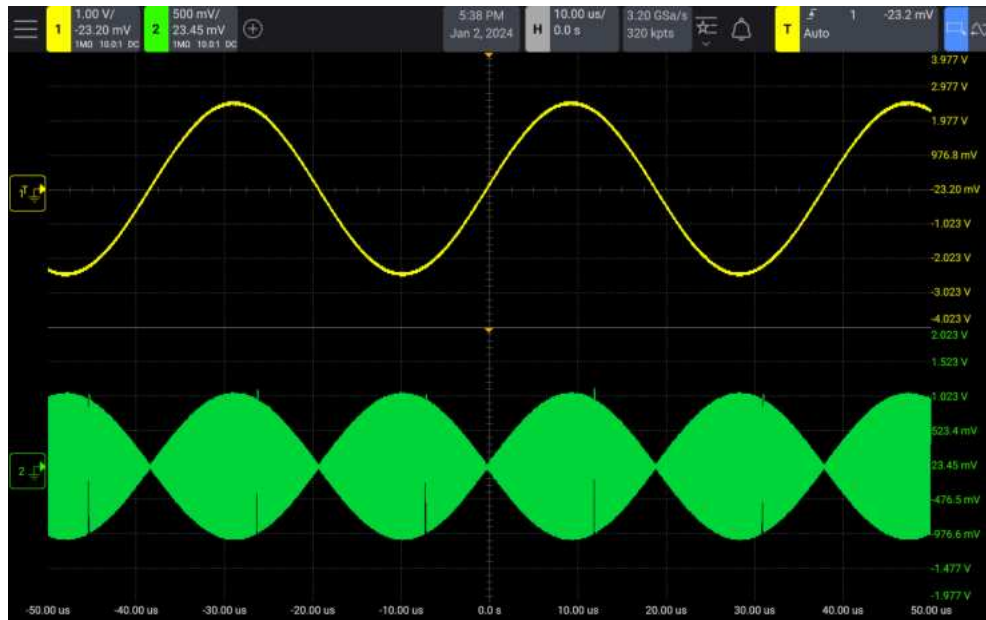


Figure 24 Amplitude Modulation Shown at 100% Intensity

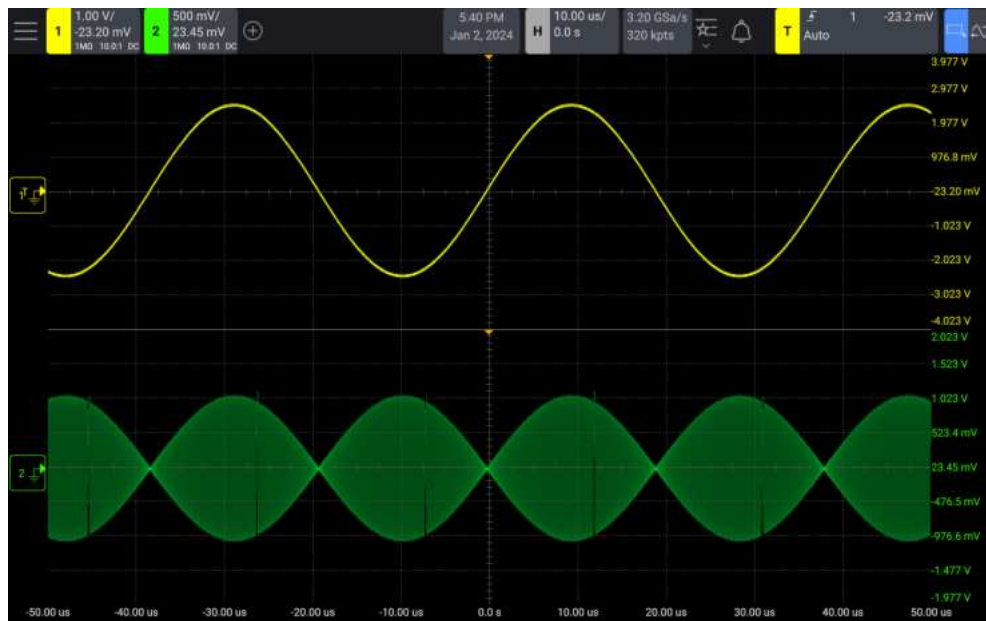


Figure 25 Amplitude Modulation Shown at 20% Intensity



# 10 Triggers

Adjusting the Trigger Level / 136

Forcing a Trigger / 137

Edge Trigger / 137

Pulse Width Trigger / 139

Pattern Trigger / 141

OR Trigger / 144

Rise/Fall Time Trigger / 144

Runt Trigger / 146

Setup and Hold Trigger / 147

Protocol Trigger / 149

Zone Qualified Trigger / 149

A trigger setup tells the oscilloscope when to acquire and display data. For example, you can set up to trigger on the rising edge of the analog channel 1 input signal.

You can use any input channel or the "**External Trigger Input**" on page 159 BNC as the source for most trigger types.

You can adjust the vertical level used for analog channel edge detection by turning the Trigger Level knob.

In addition to the edge trigger type, you can also set up triggers on rise/fall times, patterns, pulse widths, runt pulses, setup and hold violations, and protocol signals (if option licenses are installed).

Changes to the trigger setup are applied immediately. If the oscilloscope is stopped when you change a trigger setup, the oscilloscope uses the new specification when you press **[Run/Stop]** or **[Single]**. If the oscilloscope is running when you change a trigger setup, it uses the new trigger definition when it starts the next acquisition. You can save trigger setups along with the oscilloscope setup (see **Chapter 21**, "Save/Email/Recall (Setups, Screens, Data)," starting on page 261).

Options that apply to all trigger types are:

- **Mode** – Select **Auto** to automatically trigger when the specified trigger condition has not occurred for some period of time. Select **Trig'd** to turn off automatic triggering.

When triggers are not occurring, you can use the **[Force]** key to trigger on anything, acquire, and display captured data.

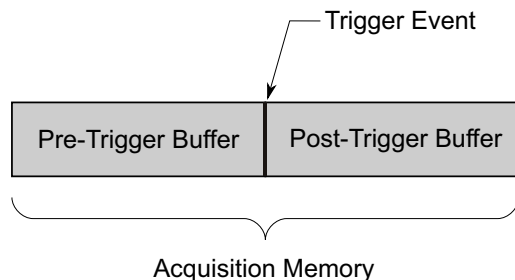
- **Conditioning...** – These options include coupling (similar to analog input channel coupling but affecting the trigger input only), holdoff, and external (AUX TRIG IN) input options.

See **Chapter 11**, “Trigger Mode and Conditioning,” starting on page 153 for more information on these options.

### Triggers - General Information

A triggered waveform is one in which the oscilloscope begins tracing (displaying) the waveform, from the left side of the display to the right, each time a particular trigger condition is met. This provides stable display of periodic signals such as sine waves and square waves, as well as nonperiodic signals such as serial data streams.

The figure below shows the conceptual representation of acquisition memory. You can think of the trigger event as dividing acquisition memory into a pre-trigger and post-trigger buffer. The position of the trigger event in acquisition memory is defined by the time reference point and the delay (horizontal position) setting (see **"To adjust the horizontal delay (position)"** on page 47).



## Adjusting the Trigger Level

The position of the trigger level for an analog channel is indicated by the trigger level icon **T▶** at the far left side of the display (if the analog channel is on). The value of the analog channel trigger level is displayed in the trigger badge.

To adjust the trigger level, you can do any of these:

- Turn the Trigger Level knob.

You can also push the Trigger Level knob to set the level of all displayed analog channels to the waveform's 50% value. If AC coupling is used, pushing the Trigger Level knob sets the trigger level to about 0 V.

When High and Low (dual) trigger levels are used (as with the Rise/Fall Time and Runt triggers, for example), pushing the Level knob toggles between high and low level adjustment.

- Drag the trigger level icon (on the left side of the waveform grid) up or down.
- Use the **Trigger Level** controls in the Trigger dialog box (that you can open by selecting the trigger badge or by choosing **Trigger > Setup...** from the main menu).
- Use the **Trigger Level** controls in the Trigger Levels dialog box (that you can open by choosing **Trigger > Trigger Levels...** from the main menu).

The Trigger Levels dialog box lets you change the trigger levels of all input channels.

The trigger level for digital channels is set in the **Thresholds** tab of the Digital dialog box. The **[Digital]** key on the front panel turns digital channels on or off. To open the Digital dialog box, choose **Sources > Digital Channels...** from the main menu or select the digital channels badge (when digital channels are on). In the **Thresholds** tab, you can specify TTL, CMOS, ECL, or user-defined threshold levels for digital channel groups.

For the **Line** input source, the trigger level is not adjustable because the trigger is synchronized with the power line supplied to the oscilloscope.

## Forcing a Trigger

The **[Force]** key causes a trigger (on anything) and displays the acquisition.

This key is useful in the **Trig'd** trigger mode (see "**To select the Auto or Trig'd trigger mode**" on page 154) where acquisitions are made only when the trigger condition is met. In this mode, if no triggers are occurring (that is, the "Trig'd?" indicator is displayed), you can press **[Force]** to force a trigger and see what the input signals look like.

In the **Auto** trigger mode, when the trigger condition does not occur within a certain period of time, triggers are forced and the "Auto?" indicator is displayed.

## Edge Trigger

The Edge trigger type identifies a trigger by looking for a specified edge (slope) and voltage level on a waveform. The trigger type, source, and level are displayed in the trigger badge.

- 1 Open the Trigger dialog box by selecting the trigger badge or by choosing **Trigger > Setup...** from the main menu.
- 2 In the **Trigger Type** drop-down list, select **Edge**.

**3** Select the trigger **Source**:

- Analog channel, **1** to the number of channels
- **External** – triggers on the AUX TRIG IN signal.
- **Line** – triggers at the 50% level of the rising or falling edge of the AC power source signal.
- **WaveGen** – triggers at the 50% level of the rising edge of the waveform generator output signal. (Not available when the DC, Noise, or Cardiac waveforms are selected.)
- **WaveGen Mod (FM)** – when waveform generator FM modulation is used, triggers at the 50% level of the rising edge of the modulating signal.
- Digital channel (on mixed-signal oscilloscopes), **D0** to the number of digital channels minus one.

You can choose a channel that is turned off (not displayed) as the source for the edge trigger.

The selected trigger source is indicated in the upper-right corner of the display next to the slope symbol:

- **1** through **4** = analog channels.
- **D0** through **Dn** = digital channels.
- **E** = External trigger input.
- **L** = Line trigger.
- **W** = Waveform generator.

**4** In the **Slope** drop-down list, select:

- **Rising** edge.
- **Falling** edge.
- **Alternating** edges – Useful when you want to trigger on both edges of a clock (for example, DDR signals).
- **Either** edge – Useful when you want to trigger on any activity of a selected source.

Rising and Falling edge modes operate up to the bandwidth of the oscilloscope. Other modes operate up to the bandwidth of the oscilloscope or 1 GHz, whichever is smaller.

The selected slope is displayed in the trigger badge.



### Using Autoscale to Set Up Edge Triggers

The easiest way to set up an Edge trigger on a waveform is to use Autoscale. Simply press the **[Auto Scale]** key and the oscilloscope will attempt to trigger on the waveform using a simple Edge trigger type. See ["Use Autoscale"](#) on page 28.

#### NOTE

### MegaZoom Technology Simplifies Triggering

With the built-in MegaZoom technology, you can simply Autoscale the waveforms, then stop the oscilloscope to capture a waveform. You can then pan and zoom through the data using the Horizontal and Vertical knobs to find a stable trigger point. Autoscale often produces a triggered display.

## Pulse Width Trigger

Pulse Width (glitch) triggering sets the oscilloscope to trigger on a positive or negative pulse of a specified width. If you want to trigger on a specific timeout value, use **Pattern** trigger (see ["Pattern Trigger"](#) on page 141).

- 1 Open the Trigger dialog box by selecting the trigger badge or by choosing **Trigger > Setup...** from the main menu.
- 2 In the **Trigger Type** drop-down list, select **Pulse Width**.
- 3 Select the **Source** channel.

The channel you select is shown in the trigger badge next to the polarity symbol.

The source can be any analog or digital channel available on your oscilloscope.

- 4 Adjust the trigger level:

- For analog channel sources, use **Trigger Level** field to enter the value.
- For digital channel sources, use the **Logic** drop-down list to select the threshold level.

The value of the trigger level or digital threshold is displayed in the upper-right corner of the display.

- 5 Use the **Slope** drop-down list to select positive ( $\uparrow$ ) or negative ( $\downarrow$ ) polarity for the pulse width you want to capture.

The selected pulse polarity is displayed in the trigger badge. A positive pulse is higher than the current trigger level or threshold and a negative pulse is lower than the current trigger level or threshold.

When triggering on a positive pulse, the trigger will occur on the high to low transition of the pulse if the qualifying condition is true. When triggering on a negative pulse, the trigger will occur on the low to high transition of the pulse if the qualifying condition is true.

- 6 Use the **Qualifier** drop-down list to select the time qualifier:

- Less than a time value ( $\lt$ ).

For example, for a positive pulse, if you set  $t \lt 10$  ns:



Use the  $\lt$  (**Less than**) field to enter the pulse width qualifier time.

The time value can be from 2 ns to 10 s (5 ns to 10 s for 350 MHz and lower bandwidth models).

- Greater than a time value ( $\gt$ ).

For example, for a positive pulse, if you set  $t \gt 10$  ns:

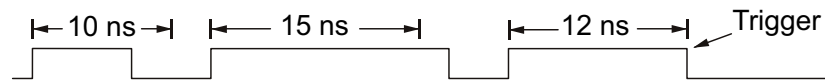


Use the  $\gt$  (**Greater than**) field to enter the pulse width qualifier time.

The time value can be from 2 ns to 10 s (5 ns to 10 s for 350 MHz and lower bandwidth models).

- Within a range of time values ( $\gt \lt$ ).

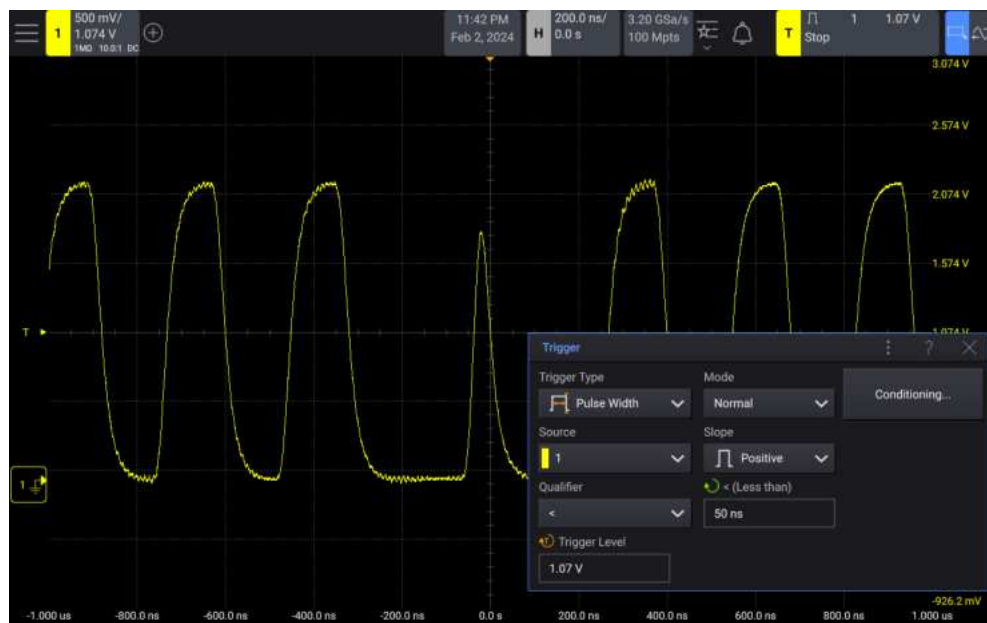
For example, for a positive pulse, if you set  $t \gt 10$  ns and  $t \lt 15$  ns:



Use the > (**Greater than**) field to enter the lower time range value.

Use the < (**Less than**) field to enter the upper time range value.

The time values can be from 10 ns to 10 s, with minimum difference of 5 ns between upper and lower settings.



## Pattern Trigger

The Pattern trigger identifies a trigger condition by looking for a specified pattern. This pattern is a logical AND combination of the channels. Each channel can have a value of 0 (low), 1 (high), or don't care (X). A rising or falling edge can be specified for one channel included in the pattern.

- 1 Open the Trigger dialog box by selecting the trigger badge or by choosing **Trigger > Setup...** from the main menu.
- 2 In the **Trigger Type** drop-down list, select **Pattern**.
- 3 From the **Qualifier** drop-down list, select from the pattern duration qualifier options:
  - **Entered** – when the pattern is entered.
  - < (Less Than) – when the pattern is present for less than a time value.

- **>** (Greater Than) – when the pattern is present for greater than a time value. The trigger occurs when the pattern exits (not when the **>** time value is exceeded).
- **Timeout** – when the pattern is present for greater than a time value. In this case, the trigger occurs when the **>** time value is exceeded (not when the pattern exits).
- **>< (In Range)** – when the pattern is present for a time within a range of values.
- **<> (Out of Range)** – when the pattern is present for a time outside of range of values.

Pattern durations are evaluated using a timer. The timer starts on the last edge that makes the pattern (logical AND) true. Except when the **Timeout** qualifier is selected, the trigger occurs on the first edge that makes the pattern false, provided the time qualifier criteria has been met.

The time values for the selected qualifier are set using the **<** and **>** qualifier time set fields.

- 4 Use the **Set All** buttons to set the pattern for all channels to **1**, **0**, or **X** (don't care).
- 5 To set the pattern for individual channels, select the channel; then, select one of the **Set Selected Channel** buttons:
  - **0** sets the pattern to zero (low) on the selected channel. A low is a voltage level that is less than the channel's trigger level or threshold level.
  - **1** sets the pattern to 1 (high) on the selected channel. A high is a voltage level that is greater than the channel's trigger level or threshold level.
  - **X** sets the pattern to don't care on the selected channel. Any channel set to don't care is ignored and is not used as part of the pattern. However, if all channels in the pattern are set to don't care, the oscilloscope will not trigger.
  - The rising edge (**↑**) or falling edge (**↓**) selections set the pattern to an edge on the selected channel. Only one rising or falling edge can be specified in the entire pattern. When an edge is specified, the oscilloscope will trigger at the edge specified if the pattern set for the other channels is true.

If no edge is specified in the entire pattern, the oscilloscope will trigger on the last edge that makes the pattern true.

#### NOTE

#### Specifying an Edge in a Pattern

You can specify only one rising or falling edge term in the pattern. If you select an edge for a channel and then select an edge for a different channel, the selection for the first channel is changed to a don't care.

When the **Entered** qualifier is selected, you can also specify patterns for digital channels using the **Bus1** and **Bus2** fields and entering hexadecimal values. See ["Hex Bus Pattern Trigger"](#) on page 143.

- 6 Select **Trigger Levels...** to open the Trigger Levels dialog box where you can adjust the trigger levels for the input channels being used.



## Hex Bus Pattern Trigger

You can specify a bus value on which to trigger. To do this, first define the bus. See ["To display digital channels as a bus"](#) on page 110 for details. You can trigger on a bus value whether you are displaying the bus or not.

To trigger on a bus value:

- 1 Select the **Pattern** trigger type and the **Entered** qualifier as described in ["Pattern Trigger"](#) on page 141.
- 2 In the **Bus1** or **Bus2** fields, enter the hex character values.

### NOTE

If a digit is made up of less than four bits, the value of the digit is limited to the greatest number that can be represented by the number of bits.

When a hex bus digit contains one or more don't care (X) bits and one or more bits with a value or 0 or 1, the "\$" sign will be displayed for the digit.

For information regarding digital bus display when Pattern triggering see ["Bus values are displayed when using Pattern trigger"](#) on page 112.

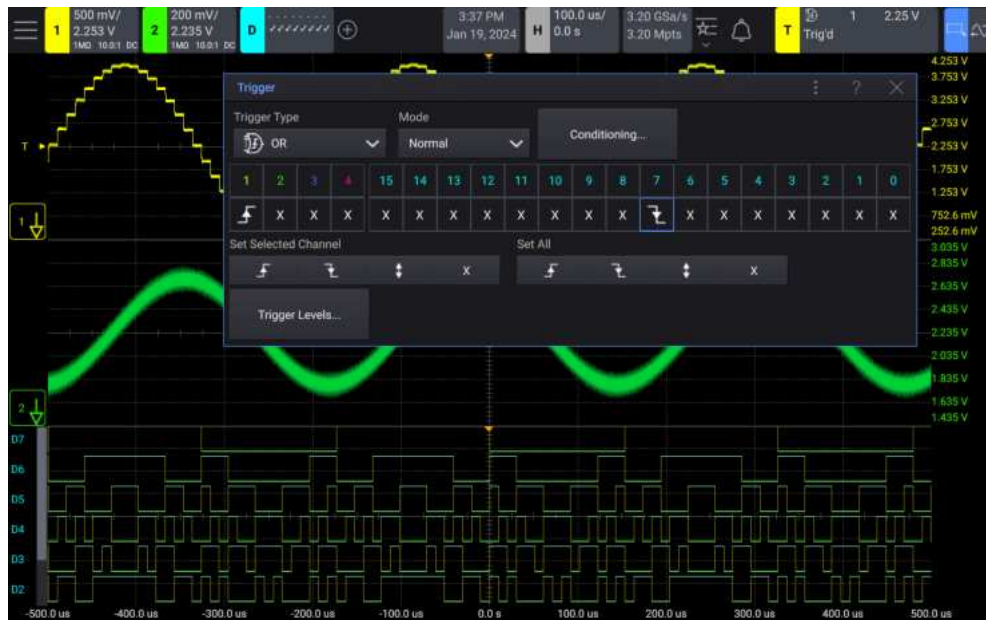
## OR Trigger

The OR trigger mode triggers when any one (or more) of the specified edges on analog or digital channels is found.

- 1 Open the **Trigger** dialog box by selecting the trigger badge or by choosing **Trigger > Setup...** from the main menu.
- 2 In the **Trigger Type** drop-down list, select **OR**.
- 3 Use the **Set All** buttons to set the edges for all channels to **↗** (Rising), **↘** (Falling), **↕** (Either), or **X** (Don't Care).
- 4 To set the edges for individual channels, select the channel; then, select one of the **Set Selected Channel** buttons: **↗** (Rising), **↘** (Falling), **↕** (Either), or **X** (Don't Care).

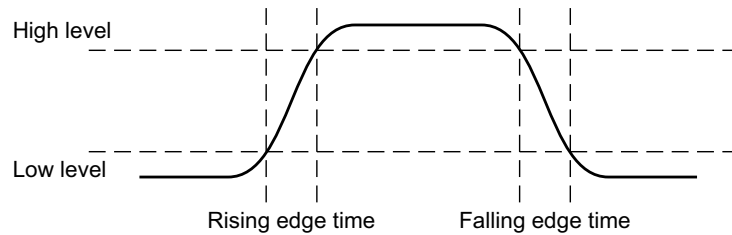
If all channels in the OR trigger are set to don't care, the oscilloscope will not trigger.

- 5 Select **Trigger Levels...** to open the Trigger Levels dialog box where you can adjust the trigger levels for the input channels being used.



## Rise/Fall Time Trigger

The Rise/Fall Time trigger looks for a rising or falling transition from one level to another level in greater than or less than a certain amount of time.



- 1 Open the Trigger dialog box by selecting the trigger badge or by choosing **Trigger > Setup...** from the main menu.
- 2 In the **Trigger Type** drop-down list, select **Rise/Fall Time**.
- 3 Select the **Source** analog channel on which to look for edges.
- 4 From the **Slope** drop-down list, select whether to look for a **↗ Rising** or **↘ Falling** edge.
- 5 From the **Qualifier** drop-down list, select:
  - **<** – When looking for an edge that is less than a time value.
  - **>** – When looking for an edge that is greater than a time value.
- 6 Select the **Time** field and enter the "less than" or "greater than" time value.
- 7 From the **Level Select** drop-down list, select which level, **High** or **Low**, the Trigger Level knob will adjust.

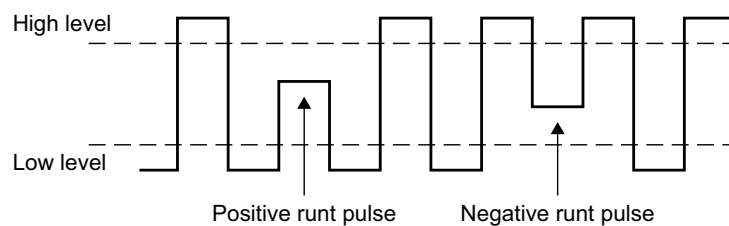
You can also push the Trigger Level knob to toggle between **High** and **Low** selection.

- 8 In addition to turning the Trigger Level knob to specify high and low levels, you can also:
  - Select the **Trigger Level: Low** field and enter the low level value.
  - Select the **Trigger Level: High** field and enter the high level value.



## Runt Trigger

The Runt trigger looks for pulses that cross one threshold but not another.



- A positive runt pulse crosses through a lower threshold but not an upper threshold.
- A negative runt pulse crosses through an upper threshold but not a lower threshold.

To trigger on runt pulses:

- 1 Open the Trigger dialog box by selecting the trigger badge or by choosing **Trigger > Setup...** from the main menu.
- 2 In the **Trigger Type** drop-down list, select **Runt**.
- 3 Select the **Source** analog channel on which to look for runt pulses.

- 4 From the **Slope** drop-down list, select whether to look for **Positive** runt pulses or **Negative** runt pulses.
- 5 From the **Qualifier** drop-down list, select:
  - **None** – When not concerned about the width of the runt pulse.
  - **<** – When looking for a runt pulse that is less than a certain width.
  - **>** – When looking for a runt pulse that is greater than a certain width.
- 6 When the "less than" or "greater than" pulse width qualifier is selected, select the **Time** field and enter the time value.
- 7 From the **Level Select** drop-down list, select which level, **High** or **Low**, the Trigger Level knob will adjust.

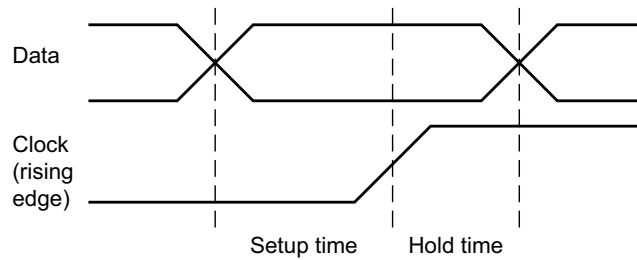
You can also push the Trigger Level knob to toggle between **High** and **Low** selection.

- 8 In addition to turning the Trigger Level knob to specify high and low levels, you can also:
  - Select the **Trigger Level: Low** field and enter the low level value.
  - Select the **Trigger Level: High** field and enter the high level value.



## Setup and Hold Trigger

The Setup and Hold trigger looks for setup and hold violations.



One oscilloscope channel probes the clock signal and another channel probes the data signal.

To trigger on setup and hold violations:

- 1 Open the Trigger dialog box by selecting the trigger badge or by choosing **Trigger > Setup...** from the main menu.
- 2 In the **Trigger Type** drop-down list, select **Setup and Hold**.
- 3 Select the **Clock** analog or digital channel with the clock signal.
- 4 From the **Slope** drop-down list, select a **Rising** or **Falling** clock edge.
- 5 Select the **Data** analog or digital channel with the data signal.
- 6 Select the **< Setup** field and enter the setup time value.
- 7 Select the **< Hold** field and enter the hold time value.
- 8 Select **Trigger Levels...** to open the Trigger Levels dialog box where you can adjust the trigger levels for the input channels being used.



## Protocol Trigger

With serial decode option licenses (see "[Protocol Decode Options](#)" on page 119), you can enable serial trigger types. To set up these triggers, see:


- "[CAN/CAN FD Triggering](#)" on page 324
- "[I2C Triggering](#)" on page 333
- "[LIN Triggering](#)" on page 342
- "[SPI Triggering](#)" on page 350
- "[UART/RS232/422/485 Triggering](#)" on page 358

## Zone Qualified Trigger

The zone qualified trigger feature gives you up to four rectangular areas, Zone 1 through Zone 4, that a waveform either must intersect or must not intersect in order for an acquisition to be displayed and stored in memory.

The zone qualified trigger feature is applied after the oscilloscope's hardware trigger, which determines the acquisitions whose waveforms are then evaluated for zone intersection.

To set up a zone qualified trigger:

- 1 Touch the upper-right corner to select the  draw box mode.
- 2 Drag your finger (or connected USB mouse pointer) across the screen to draw a rectangular zone that the waveform must either intersect or not intersect.
- 3 Take your finger off the screen (or release the mouse button).
- 4 In the pop-up menu, select one of these options:
  - **Add Zone Trigger - Must Intersect** – Adds a new "Must Intersect" zone.
  - **Add Zone Trigger - Must Not Intersect** – Adds a new "Must Not Intersect" zone.
  - **Replace Zone Trigger - Must Intersect** – Replaces an existing zone with a "Must Intersect" zone.
  - **Replace Zone Trigger - Must Not Intersect** – Replaces an existing zone with a "Must Intersect" zone.



5 If there are multiple waveforms in a grid or existing zones, a dialog box appears:

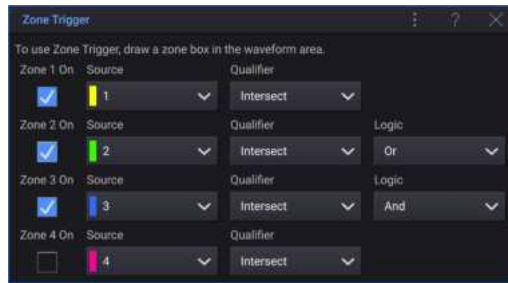


- **Zone** – When replacing an existing zone, this drop-down list lets you select the zone being replaced.
- **Source** – Selects the analog channel input source that the zone is associated with.
- **Logic** – When combined with other zones, specifies whether this zone is ANDed or ORed with the previous zone.

Zones can be dragged on the screen using the center handle. Zones can be resized using the lower-right corner handle.



The upper-right corner edit (pencil) icon opens the full Zone Trigger dialog box.



The Zone Trigger dialog box has these controls:

- **Zone N On** – Enables or disables the Zone.
- **Source** – Selects the analog channel input source the Zones is associated with.

Zone colors match the selected analog input channel. "Must Not Intersect" zones are shaded differently than the solid "Must Intersect" zones.

The zone qualified trigger source does not have to be the same as the hardware trigger source.

- **Qualifier** – Specifies whether the Zone is a **Must Intersect** zone or **Must Not Intersect** zone.
- **Logic** – When combined with other zones, specifies whether the Zone is ANDed or ORed with the previous zone.

The **Zone Logic** is displayed at the top of the grid.

Disabling all zones disables the zone qualified trigger feature. When the zone qualified trigger feature is enabled, at least one zone must be enabled.

The zone qualified trigger feature is incompatible with, and will disable, the the Averaging acquisition mode.

#### NOTE

Keep in mind that the AUX OUT signal comes from the oscilloscope's hardware trigger. The AUX OUT signal indicates when there is a trigger (acquisition) that is evaluated for zone intersection, not when an acquisition meets the zone qualification and is plotted on the oscilloscope's display.



# 11 Trigger Mode and Conditioning

To select the Auto or Trig'd trigger mode / 154

To select the trigger coupling / 155

To enable or disable trigger noise rejection / 157

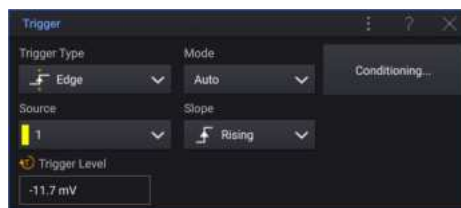
To enable or disable trigger HF Reject / 157

To disable or reenable trigger hysteresis / 158

To set the trigger holdoff / 158

External Trigger Input / 159

The trigger **Mode** and **Conditioning...** options are available in the Trigger dialog box with all trigger types:



- **Mode** – Select **Auto** to automatically trigger when the specified trigger condition has not occurred for some period of time. Select **Trig'd** to turn off automatic triggering.

When triggers are not occurring, you can use the **[Force]** key to trigger on anything, acquire, and display captured data.

- **Conditioning...** – These options include coupling (similar to analog input channel coupling but affecting the trigger input only), holdoff, and external (AUX TRIG IN) input options.

You can also open the Conditioning dialog box by choosing **Trigger > Conditioning...** from the main menu.

**Noisy Signals** If the signal you are probing is noisy, you can set up the oscilloscope to reduce the noise in the trigger path and on the displayed waveform. First, stabilize the displayed waveform by removing the noise from the trigger path. Second, reduce the noise on the displayed waveform.

- 1 Connect a signal to the oscilloscope and obtain a stable display.
- 2 Remove the noise from the trigger path by turning on high-frequency rejection ("**To enable or disable trigger HF Reject**" on page 157), low-frequency rejection ("**To select the trigger coupling**" on page 155), or "**To enable or disable trigger noise rejection**" on page 157.
- 3 Use "**Averaging Acquisition Mode**" on page 169 to reduce noise on the displayed waveform.

## To select the Auto or Trig'd trigger mode

When the oscilloscope is running, the trigger mode tells the oscilloscope what to do when triggers are not occurring.

In the **Auto** trigger mode (the default setting), if the specified trigger conditions are not found, triggers are forced and acquisitions are made so that signal activity is displayed on the oscilloscope.

In the **Trig'd** trigger mode, triggers and acquisitions only occur when the specified trigger conditions are found.

To select the trigger mode:

- 1 Open the Trigger dialog box (by selecting the trigger badge or by choosing **Trigger > Setup...** from the main menu).
- 2 Select the **Mode** drop-down list; then, select either **Auto** or **Trig'd**.

See the following "**When to Use Auto Trigger Mode**" on page 155 and "**When to Use Trig'd Trigger Mode**" on page 155 descriptions.

You can also configure the **Setup > (Quick Action)** menu item to toggle between the Auto and Trig'd trigger modes. See "**Configuring the (Quick Action) Menu Item**" on page 291.

### Triggering and the Pre- and Post-Trigger Buffers

After the oscilloscope starts running (after pressing **[Run]** or **[Single]** or changing the trigger condition), the oscilloscope first fills the pre-trigger buffer. Then, after the pre-trigger buffer is filled, the oscilloscope starts searching for a trigger, and sampled data continues to flow data through the pre-trigger buffer in a first-in first-out (FIFO) manner.

When a trigger is found, the pre-trigger buffer contains the events that occurred just before the trigger. Then, the oscilloscope fills the post-trigger buffer and displays the acquisition memory. If the acquisition was initiated by **[Run/Stop]**, the process repeats. If the acquisition was initiated by pressing **[Single]**, the acquisition stops (and you can Pan and Zoom the waveform).

In either Auto or Trig'd trigger mode, a trigger may be missed if the event occurs while the pre-trigger buffer is being filled. This may be more likely, for example, when the horizontal scale knob is set to a slow time/div setting, such as 500 ms/div.

**Trigger Indicator** The trigger indicator in the trigger badge shows whether triggers are occurring.

In the **Auto** trigger mode, the trigger indicator can show:

- **Auto?** – the trigger condition is not found (after the pre-trigger buffer has filled), and forced triggers and acquisitions are occurring.
- **Auto** – the trigger condition is found (or the pre-trigger buffer is being filled).

In the **Trig'd** trigger mode, the trigger indicator can show:

- **Trig'd?** – the trigger condition is not found (after the pre-trigger buffer has filled), and no acquisitions are occurring.
- **Trig'd** – trigger condition is found (or pre-trigger buffer is being filled).

When the oscilloscope is not running, the trigger indicator area shows **Stop**.

**When to Use Auto Trigger Mode** The **Auto** trigger mode is appropriate when:

- Checking DC signals or signals with unknown levels or activity.
- When trigger conditions occur often enough that forced triggers are unnecessary.

**When to Use Trig'd Trigger Mode** The **Trig'd** trigger mode is appropriate when:

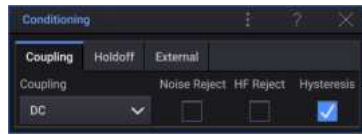
- You only want to acquire specific events specified by the trigger settings.
- Triggering on an infrequent signal from a serial bus (for example, I2C, SPI, CAN, LIN, etc.) or another signal that arrives in bursts. The **Trig'd** trigger mode lets you stabilize the display by preventing the oscilloscope from auto-triggering.
- Making single-shot acquisitions with the **[Single]** key.

Often with single-shot acquisitions, you must initiate some action in the device under test, and you don't want the oscilloscope to auto-trigger before that happens. Before initiating the action in the circuit, wait for the trigger condition indicator **Trig'd?** to display (this tells you the pre-trigger buffer is filled).

- See Also**
- **"Forcing a Trigger"** on page 137
  - **"To set the trigger holdoff"** on page 158
  - **"To position the time reference (left, center, right, custom)"** on page 50

## To select the trigger coupling

- 1 Open the Conditioning dialog box by selecting **Conditioning...** in the Trigger dialog box or by choosing choose **Trigger > Conditioning...** from the main menu.
- 2 In the Conditioning dialog box, select the **Coupling** tab.



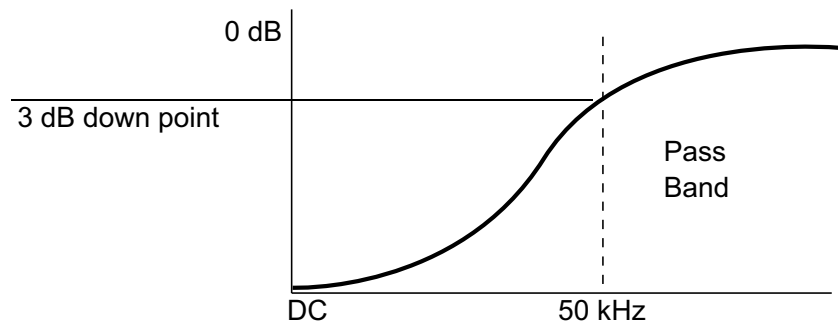
**3** From the **Coupling** drop-down list, select:

- **DC** coupling – Allows DC and AC signals into the trigger path.
- **AC** coupling – Places a 10 Hz high-pass filter in the trigger path removing any DC offset voltage from the trigger waveform.

The high-pass filter in the External Trigger input path is 50 Hz for all models.

Use AC coupling to get a stable edge trigger when your waveform has a large DC offset.

- **LF (low frequency) Reject** coupling – Adds a high-pass filter with the 3-dB point at 50 kHz in series with the trigger waveform.



Low frequency reject removes any unwanted low frequency components from a trigger waveform, such as power line frequencies, etc., that can interfere with proper triggering.

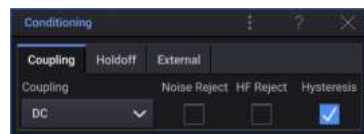
Use **LF Reject** coupling to get a stable edge trigger when your waveform has low frequency noise.

Note that Trigger Coupling is independent of Channel Coupling (see **"To specify channel coupling"** on page 57).

## To enable or disable trigger noise rejection

Noise Rej adds additional hysteresis to the trigger circuitry. By increasing the trigger hysteresis band, you reduce the possibility of triggering on noise. However, this also decreases the trigger sensitivity so that a slightly larger signal is required to trigger the oscilloscope.

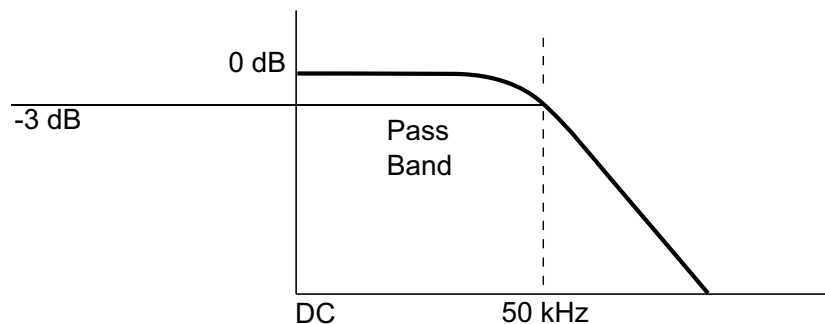
- 1 Open the Conditioning dialog box by selecting **Conditioning...** in the Trigger dialog box or by choosing **Trigger > Conditioning...** from the main menu.
- 2 In the Conditioning dialog box, select the **Coupling** tab.



- 3 Select the **Noise Reject** check box to enable or disable.

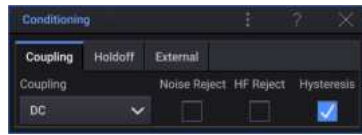
## To enable or disable trigger HF Reject

HF Reject adds a 50 kHz low-pass filter in the trigger path to remove high frequency components from the trigger waveform.



You can use HF Reject to remove high-frequency noise, such as AM or FM broadcast stations or noise from fast system clocks, from the trigger path.

- 1 Open the Conditioning dialog box by selecting **Conditioning...** in the Trigger dialog box or by choosing **Trigger > Conditioning...** from the main menu.
- 2 In the Conditioning dialog box, select the **Coupling** tab.



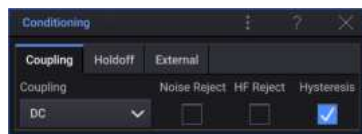
- 3 Select the **HF Reject** check box to enable or disable.

## To disable or reenabling trigger hysteresis

Oscilloscope triggers use hysteresis techniques to reduce false triggering on noisy signals. This oscilloscope's fully digital triggers implement hysteresis as a sensitivity limit. The default hysteresis setting (enabled) delivers optimal triggering performance for almost all signals.

By disabling hysteresis, the sensitivity of the trigger drops to one least significant bit (LSB). It is limited only by the noise floor of the signal and oscilloscope. You must be mindful of signal and measurement noise to avoid false triggers. This mode is often paired with Bandwidth Limit filters or Averaging (see ["Selecting a Global Bandwidth Limit and Vertical Resolution"](#) on page 171 or ["Averaging Acquisition Mode"](#) on page 169).

- 1 Open the Conditioning dialog box by selecting **Conditioning...** in the Trigger dialog box or by choosing **Trigger > Conditioning...** from the main menu.
- 2 In the Conditioning dialog box, select the **Coupling** tab.



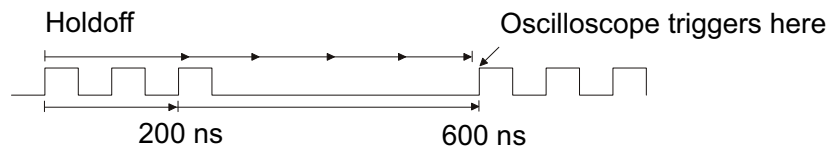
- 3 Clear or select the **Hysteresis** check box to disable or reenabling.

## To set the trigger holdoff

Trigger holdoff sets the amount of time the oscilloscope waits after a trigger before re-arming the trigger circuitry.

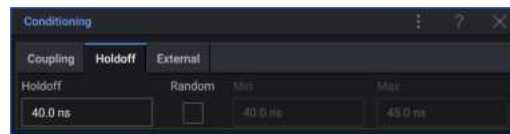
Use the holdoff to trigger on repetitive waveforms that have multiple edges (or other events) between waveform repetitions. You can also use holdoff to trigger on the first edge of a burst when you know the minimum time between bursts.

For example, to get a stable trigger on the repetitive pulse burst shown below, set the holdoff time to be  $>200$  ns but  $<600$  ns.



To set the trigger holdoff:

- 1 Open the Conditioning dialog box by selecting **Conditioning...** in the Trigger dialog box or by choosing **Trigger > Conditioning...** from the main menu.
- 2 In the Conditioning dialog box, select the **Holdoff** tab.



- 3 Select the **Random** check box to enable or disable the random trigger holdoff mode.

The random trigger holdoff mode ensures that the oscilloscope re-arms after each acquisition in a manner that minimizes or eliminates the likelihood of triggering at the beginning of a DDR burst. Randomizing the holdoff time increases the likelihood that the oscilloscope will trigger on different data phases of a multi-phase (8 data transfer) burst. This mode mixes up the traffic pattern the oscilloscope triggers on and is very effective when used on repeating patterns.

- 4 If random trigger holdoff is disabled, select the **Holdoff** field and enter the trigger holdoff time.

If random trigger holdoff is enabled, select the **Min** and **Max** fields and enter the minimum and maximum trigger holdoff times.

#### Trigger Holdoff Operating Hints

The correct holdoff setting is typically slightly less than one repetition of the waveform. Set the holdoff to this time to generate a unique trigger point for a repetitive waveform.

Changing the time base settings does not affect the trigger holdoff time.

With Keysight's MegaZoom technology, you can press **[Stop]**, then pan and zoom through the data to find where the waveform repeats. Measure this time using markers; then, set the holdoff.

## External Trigger Input

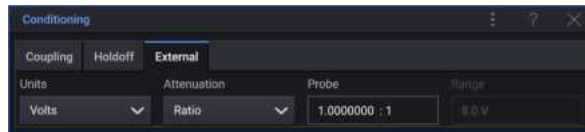
The external trigger input can be used as a source in several of the trigger types. The external trigger BNC input is labeled **AUX TRIG IN**.

**CAUTION****⚠ Maximum voltage at oscilloscope external trigger input****±5 V**

The external trigger input impedance is 1M Ohm. This lets you use passive probes for general-purpose measurements. The higher impedance minimizes the loading effect of the oscilloscope on the device under test.


To set the AUX TRIG IN units and probe attenuation:

- 1 Open the Conditioning dialog box by selecting **Conditioning...** in the Trigger dialog box or by choosing **Trigger > Conditioning...** from the main menu.
- 2 In the Conditioning dialog box, select the **External** tab.



- 3 From the **Units** drop-down list, select between:
  - **Volts** – For a voltage probe.
  - **Amps** – For a current probe.

Measurement results, channel sensitivity, and the trigger level will reflect the measurement units you have selected.

- 4 Select how you want to specify the **Attenuation** factor, choosing either **Ratio** or **Decibels**.
- 5 Select the **Probe** attenuation factor field; then, turn the Entry knob  to set the attenuation factor for the connected probe.

The attenuation factor can be set from 0.001:1 to 10000:1 in a 1-2-5 sequence.

When specifying the attenuation factor in decibels, you can select values from -20 dB to 80 dB.

The probe attenuation factor must be set properly for measurements to be made correctly.

As you adjust the **Probe** attenuation factor, the **Range** field shows you the range of values that can appear on the external trigger input.

# 12 Acquisition Control

Running, Stopping, and Making Single Acquisitions (Run Control) / 161

Overview of Sampling / 162

Selecting the Acquisition Mode / 166

Selecting a Global Bandwidth Limit and Vertical Resolution / 171

Acquiring to Segmented Memory / 171

Digitizer Mode / 174

This chapter shows how to use the oscilloscope's acquisition and run controls.

## Running, Stopping, and Making Single Acquisitions (Run Control)

There are two front panel keys for starting and stopping the oscilloscope's acquisition system: **[Run/Stop]** and **[Single]**.

- When the **[Run/Stop]** key is green, the oscilloscope is running, that is, acquiring data when trigger conditions are met.

To stop acquiring data, press **[Run/Stop]**. When stopped, the last acquired waveform is displayed.

- When the **[Run/Stop]** key is red, data acquisition is stopped.

"Stop" is displayed next to the trigger type in the trigger badge.

To start acquiring data, press **[Run/Stop]**.

- To capture and display a single acquisition (whether the oscilloscope is running or stopped), press **[Single]**.

The **[Single]** run control lets you view single-shot events without subsequent waveform data overwriting the display. Use **[Single]** when you want maximum memory depth for pan and zoom.

When you press **[Single]**, the trigger mode is temporarily set to Trig'd (to keep the oscilloscope from auto-triggering immediately), the trigger circuitry is armed, the **[Single]** key is illuminated, and the oscilloscope waits until a trigger condition occurs before it displays a waveform.

When the oscilloscope triggers, the single acquisition is displayed and the oscilloscope is stopped (the **[Run/Stop]** key is illuminated in red). Press **[Single]** again to acquire another waveform.

If the oscilloscope does not trigger, you can press the **[Force]** key to trigger on anything and make a single acquisition.

To display the results of multiple acquisitions, use persistence. See "**To set or clear persistence**" on page 124.

#### Single vs. Running and Record Length

The maximum data record length is greater for a single acquisition than when the oscilloscope is running (or when the oscilloscope is stopped after running).

To acquire data with the longest possible record length, press the **[Single]** key.

For more information on settings that affect record length, see "**Length Control**" on page 265.

## Overview of Sampling

To understand the oscilloscope's sampling and acquisition modes, it is helpful to understand sampling theory, aliasing, oscilloscope bandwidth and sample rate, oscilloscope rise time, oscilloscope bandwidth required, and how memory depth affects sample rate.

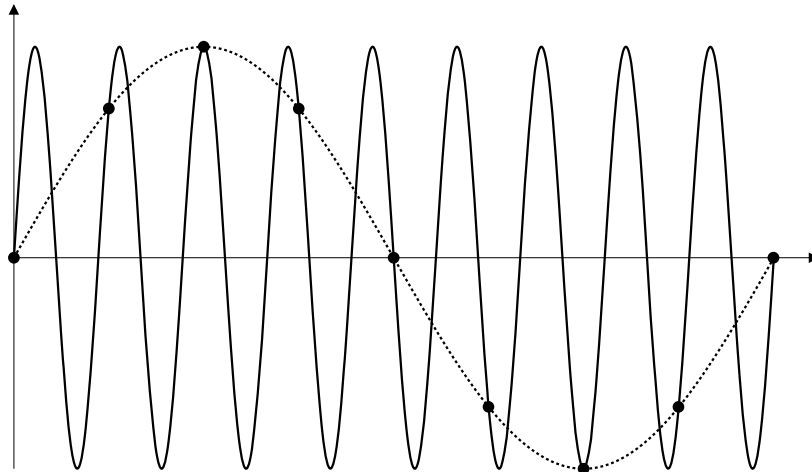
### Sampling Theory

The Nyquist sampling theorem states that for a limited bandwidth (band-limited) signal with maximum frequency  $f_{MAX}$ , the equally spaced sampling frequency  $f_S$  must be greater than twice the maximum frequency  $f_{MAX}$ , in order to have the signal be uniquely reconstructed without aliasing.

$$f_{MAX} = f_S/2 = \text{Nyquist frequency } (f_N) = \text{folding frequency}$$

### Aliasing

Aliasing occurs when signals are under-sampled ( $f_S < 2f_{MAX}$ ). Aliasing is the signal distortion caused by low frequencies falsely reconstructed from an insufficient number of sample points.

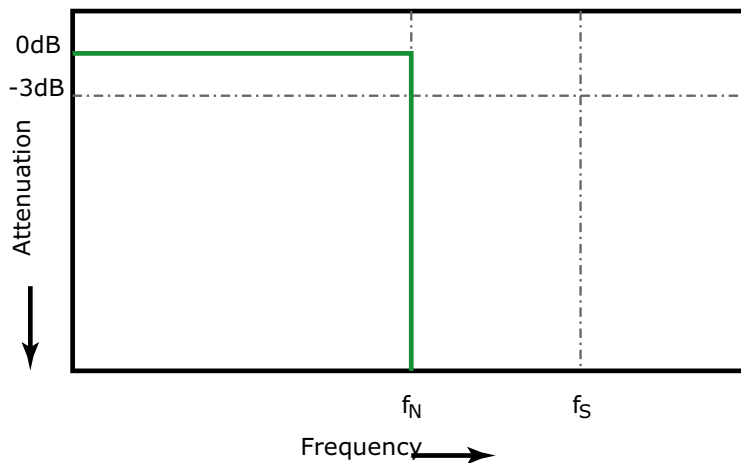


**Figure 26** Aliasing

## Oscilloscope Bandwidth and Sample Rate

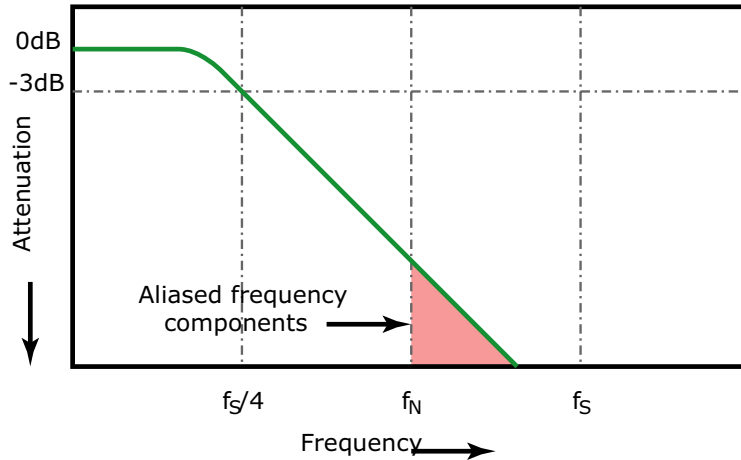
An oscilloscope's bandwidth is typically described as the lowest frequency at which input signal sine waves are attenuated by 3 dB (-30% amplitude error).

At the oscilloscope bandwidth, sampling theory says the required sample rate is  $f_s = 2f_{BW}$ . However, the theory assumes there are no frequency components above  $f_{MAX}$  ( $f_{BW}$  in this case) and it requires a system with an ideal brick-wall frequency response.



**Figure 27** Theoretical Brick-Wall Frequency Response

However, digital signals have frequency components above the fundamental frequency (square waves are made up of sine waves at the fundamental frequency and an infinite number of odd harmonics), and typically, for 500 MHz bandwidths and below, oscilloscopes have a Gaussian frequency response.



Limiting oscilloscope bandwidth (fbw) to 1/4 the sample rate (fs/4) reduces frequency components above the Nyquist frequency (fN).

**Figure 28** Sample Rate and Oscilloscope Bandwidth

So, in practice, an oscilloscope's sample rate should be four or more times its bandwidth:  $f_s = 4f_{BW}$ . This way, there is less aliasing, and aliased frequency components have a greater amount of attenuation.

Note that 1 GHz bandwidth HD3-Series oscilloscope models have more of a brick-wall type frequency response than the Gaussian response of lower bandwidth HD3-Series oscilloscope models. To understand the characteristics of each type of oscilloscope frequency response, see *Understanding Oscilloscope Frequency Response and Its Effect on Rise-Time Accuracy*, Keysight Application Note 1420 (<http://literature.cdn.keysight.com/litweb/pdf/5988-8008EN.pdf>).

**See Also** *Evaluating Oscilloscope Sample Rates vs. Sampling Fidelity: How to Make the Most Accurate Digital Measurements*, Keysight Application Note 1587 (<http://literature.cdn.keysight.com/litweb/pdf/5989-5732EN.pdf>)

## Oscilloscope Rise Time

Closely related to an oscilloscope's bandwidth specification is its rise time specification. Oscilloscopes with a Gaussian-type frequency response have an approximate rise time of  $0.35/f_{BW}$  based on a 10% to 90% criterion.

An oscilloscope's rise time is not the fastest edge speed that the oscilloscope can accurately measure. It is the fastest edge speed the oscilloscope can possibly produce.

## Oscilloscope Bandwidth Required

The oscilloscope bandwidth required to accurately measure a signal is primarily determined by the signal's rise time, not the signal's frequency. You can use these steps to calculate the oscilloscope bandwidth required:

- 1 Determine the fastest edge speeds.

You can usually obtain rise time information from published specifications for devices used in your designs.

- 2 Compute the maximum "practical" frequency component.

From Dr. Howard W. Johnson's book, *High-Speed Digital Design – A Handbook of Black Magic*, all fast edges have an infinite spectrum of frequency components. However, there is an inflection (or "knee") in the frequency spectrum of fast edges where frequency components higher than  $f_{knee}$  are insignificant in determining the shape of the signal.

$$f_{knee} = 0.5 / \text{signal rise time (based on 10\% - 90\% thresholds)}$$

$$f_{knee} = 0.4 / \text{signal rise time (based on 20\% - 80\% thresholds)}$$

- 3 Use a multiplication factor for the required accuracy to determine the oscilloscope bandwidth required.

Required accuracy	Oscilloscope bandwidth required
20%	$f_{BW} = 1.0 \times f_{knee}$
10%	$f_{BW} = 1.3 \times f_{knee}$
3%	$f_{BW} = 1.9 \times f_{knee}$

**See Also** *Choosing an Oscilloscope with the Right Bandwidth for your Application*, Keysight Application Note 1588  
(<http://literature.cdn.keysight.com/litweb/pdf/5989-5733EN.pdf>)

## Memory Depth and Sample Rate

The number of points of oscilloscope memory is fixed, and there is a maximum sample rate associated with oscilloscope's analog-to-digital converter; however, the actual sample rate is determined by the time of the acquisition (which is set according to the oscilloscope's horizontal time/div scale).

$$\text{sample rate} = \text{number of samples} / \text{time of acquisition}$$

For example, when storing 500 ms of data in 50,000,000 points of memory, the actual sample rate is 100 MSa/s.

Likewise, when storing 50 ms of data in 50,000,000 points of memory, the actual sample rate is 1 GSa/s.

The actual sample rate is displayed in the sample rate and memory depth (Acquire) badge at the top of the display.

The oscilloscope achieves the actual sample rate by throwing away (decimating) unneeded samples.

## Selecting the Acquisition Mode

When selecting the oscilloscope acquisition mode, keep in mind that samples are normally decimated at slower time/div settings.

At slower time/div settings, the effective sample rate drops (and the effective sample period increases) because the acquisition time increases and the oscilloscope's digitizer is sampling faster than is required to fill memory.

For example, suppose an oscilloscope's digitizer has a sample period of 1 ns (maximum sample rate of 1 GSa/s) and a 1 M memory depth. At that rate, memory is filled in 1 ms. If the acquisition time is 100 ms (10 ms/div), only 1 of every 100 samples is needed to fill memory.

To select the acquisition mode:

- 1 Open the Acquire dialog box by selecting the sample rate and memory depth (Acquire) badge or by choosing **Setup > Acquire...** from the main menu.
- 2 In the Acquire dialog box, from the **Acq Mode** drop-down list, select the acquisition mode:
  - **Normal** – at slower time/div settings, normal decimation occurs, and there is no averaging. Use this mode for most waveforms. See "**Normal Acquisition Mode**" on page 167.
  - **Peak Detect** – at slower time/div settings, the maximum and minimum samples in the effective sample period are stored. Use this mode for displaying narrow pulses that occur infrequently. See "**Peak Detect Acquisition Mode**" on page 167.
  - **Averaging** – at all time/div settings, the specified number of triggers are averaged together. Use this mode for reducing noise and increasing resolution of periodic signals without bandwidth or rise time degradation. See "**Averaging Acquisition Mode**" on page 169.

## Normal Acquisition Mode

In Normal mode at slower time/div settings, extra samples are decimated (in other words, some are thrown away). This mode yields the best display for most waveforms.

## Peak Detect Acquisition Mode

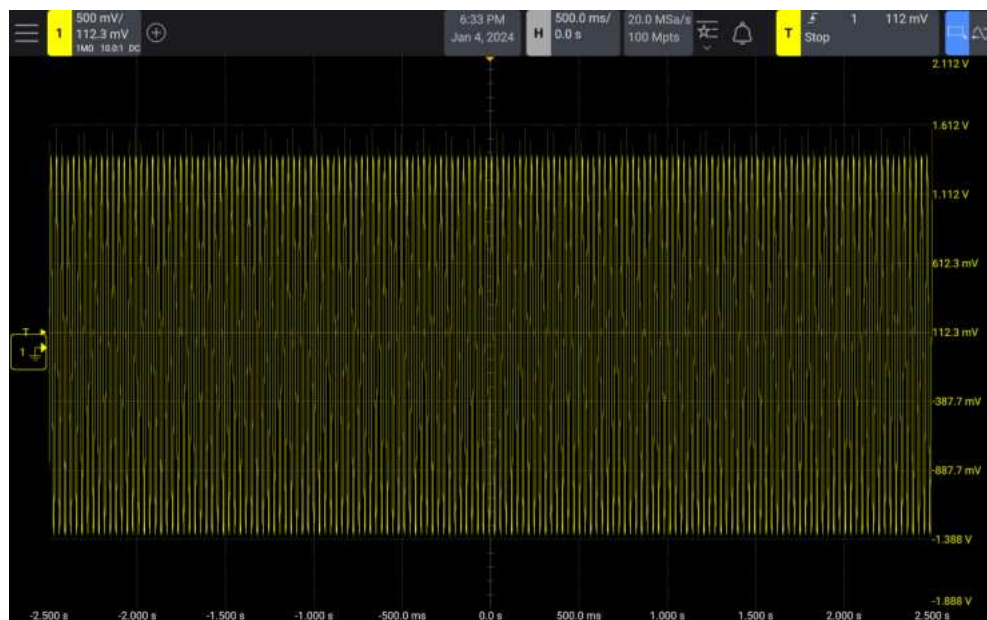
In Peak Detect mode at slower time/div settings, minimum and maximum samples are kept in order to capture infrequent and narrow events (at the expense of exaggerating any noise). This mode displays all pulses that are at least 100 ps wide.

- See Also
- ["Glitch or Narrow Pulse Capture"](#) on page 167
  - ["Using Peak Detect Mode to Find a Glitch"](#) on page 168

## Glitch or Narrow Pulse Capture

A glitch is a rapid change in the waveform that is usually narrow as compared to the waveform. Peak Detect acquisition mode can be used to more easily view glitches or narrow pulses. In Peak Detect mode, narrow glitches and sharp edges are displayed more brightly than when in Normal acquisition mode, making them easier to see.

To characterize the glitch, use the markers or the automatic measurement capabilities of the oscilloscope.



**Figure 29** Sine With Glitch, Normal Mode



**Figure 30** Sine With Glitch, Peak Detect Mode

### Using Peak Detect Mode to Find a Glitch

- 1 Connect a signal to the oscilloscope and obtain a stable display.
- 2 Open the Acquire dialog box by selecting the sample rate and memory depth (Acquire) badge or by choosing **Setup > Acquire...** from the main menu.
- 3 In the Acquire dialog box, from the **Acq Mode** drop-down list, select the **Peak Detect** acquisition mode.
- 4 From the menu, choose **Setup > Display...**
- 5 In the Display dialog box, select the **Persistence** tab.
- 6 Select the **Persistence** field, and select  $\infty$  Persistence.

Infinite persistence updates the display with new acquisitions but does not erase previous acquisitions. New sample points are shown at normal intensity while previous acquisitions are displayed at reduced intensity. Waveform persistence is not kept beyond the display area boundary.

Press **[Clear Display]** key to erase previously acquired points. The display will accumulate points until  $\infty$  **Persistence** is turned off.

- 7 Characterize the glitch with Zoom mode:
  - a Press the **[Zoom]** key.
  - b To obtain a better resolution of the glitch, expand the time base.

Use the horizontal position knob ( $\blacktriangleleft\blacktriangleright$ ) to pan through the waveform to set the expanded portion of the normal window around the glitch.

## Averaging Acquisition Mode

The Averaging mode lets you average multiple acquisitions together to reduce noise and increase vertical resolution (at all time/div settings). Averaging requires a stable trigger.

The number of averages can be set from 2 to 65536 in power-of-2 increments.

A higher number of averages reduces noise more and increases vertical resolution.

# Avgs	Bits of resolution
2	14
≥ 4	16

The higher the number of averages, the slower the displayed waveform responds to waveform changes. You must compromise between how quickly the waveform responds to changes and how much you want to reduce the displayed noise on the signal.

To use the Averaging mode:

- 1 Open the Acquire dialog box by selecting the sample rate and memory depth (Acquire) badge or by choosing **Setup > Acquire...** from the main menu.
- 2 In the Acquire dialog box, from the **Acq Mode** drop-down list, select the **Averaging** acquisition mode.
- 3 Select the **# of Averages** field and turn the Entry knob to set the number of averages that best eliminates the noise from the displayed waveform.



**Figure 31** Random noise on the displayed waveform



**Figure 32** 128 Averages used to reduce random noise

When the Averaging acquisition mode is enabled, a Single acquisition will perform the selected number of averages and then stop.

See Also • [Chapter 11](#), “Trigger Mode and Conditioning,” starting on page 153

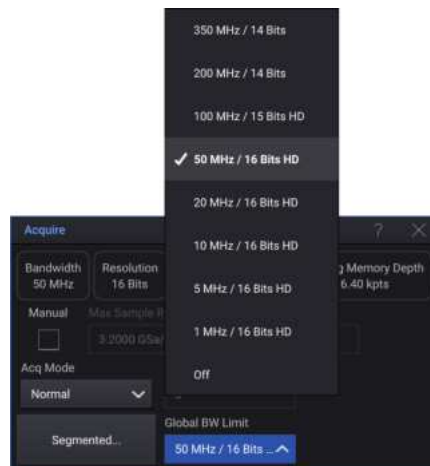
- **"Averaged Value"** on page 90

## Selecting a Global Bandwidth Limit and Vertical Resolution

Limiting the channel bandwidth with digital filters lets you remove unwanted high frequency noise from the waveform and potentially increase the number of bits of vertical resolution.

To select a global channel bandwidth limit and vertical resolution:

- 1 Open the Acquire dialog box by selecting the sample rate and memory depth (Acquire) badge or by choosing **Setup > Acquire...** from the main menu.
- 2 In the Acquire dialog box, use the **Global BW Limit** drop-down list to disable or enable global channel bandwidth limiting.



The selections that improve the number of bits of vertical resolution are marked with "HD" (high-definition).

Note that each channel also has an independent **40 MHz BW Limit** option. See **"To specify bandwidth limiting"** on page 59. When the global bandwidth limit and an individual channel bandwidth limit are both selected, the lower bandwidth limit is applied.

## Acquiring to Segmented Memory

When capturing multiple infrequent trigger events it is advantageous to divide the oscilloscope's memory into segments. This lets you capture signal activity without capturing long periods of signal inactivity.

Each segment is complete with all analog channel, digital channel, and serial decode data.

When using segmented memory, use the Analyze Segments feature (see ["Measurements, Statistics, and Infinite Persistence with Segmented Memory"](#) on page 173) to show infinite persistence across all acquired segments. See also ["To set or clear persistence"](#) on page 124 for details.

**To acquire to segmented memory**

- 1 Set up a trigger condition. (See [Chapter 10](#), "Triggers," starting on page 135 for details.)
- 2 Open the Acquire dialog box by selecting the sample rate and memory depth (Acquire) badge or by choosing **Setup > Acquire...** from the main menu.
- 3 In the Acquire dialog box, select **Segmented...**
- 4 In the Segmented dialog box, select the **# of Segments** field and turn the Entry knob to select the number of segments into which you would like to divide the oscilloscope's memory.

Memory can be divided into as few as two segments and as many as 1000 segments, depending on the oscilloscope model.

- 5 Select the **Segmented** check box to enable segmented memory acquisitions.
- 6 Press the **[Run]** or **[Single]** key.

The oscilloscope runs and fills a memory segment for each trigger event. When the oscilloscope is busy acquiring multiple segments, the progress is displayed on screen. The oscilloscope continues to trigger until memory is filled, then the oscilloscope stops.

If the signal you are measuring has more than about 1 s of inactivity, consider selecting the **Trig'd** trigger mode to prevent Auto triggering. See ["To select the Auto or Trig'd trigger mode"](#) on page 154.

- See Also**
- ["Navigating Segments"](#) on page 173
  - ["Measurements, Statistics, and Infinite Persistence with Segmented Memory"](#) on page 173
  - ["Segmented Memory Re-Arm Time"](#) on page 173
  - ["Saving Data from Segmented Memory"](#) on page 174

## Navigating Segments

- 1 In the Segmented dialog box, select the **Current Seg** field, and turn the Entry knob to display the desired segment along with a time tag indicating the time from the first trigger event.



You can also navigate segments using the **Analyze > Navigate...** menu item, the Navigate dialog box, and its controls. See "**To navigate segments**" on page 53.

## Measurements, Statistics, and Infinite Persistence with Segmented Memory

To perform measurements and view statistical information, choose **Measure > Measurements...** from the main menu and set up your desired measurements (see [Chapter 14](#), "Measurements," starting on page 185). Then, in the Segmented dialog box, select **Analyze Segments**. Statistical data will be accumulated for the measurements you have chosen.

When the segmented memory feature is on and acquisitions is stopped, the **Analyze Segments** button is available when features like measurements, infinite persistence, histograms, or protocol listing are on.

## Segmented Memory Re-Arm Time

After each segment fills, the oscilloscope re-arms and is ready to trigger in about 1  $\mu$ s.

Remember though, for example: if the horizontal time per division control is set to  $5\ \mu\text{s}/\text{div}$ , and the Time Reference is set to **Center**, it will take at least  $50\ \mu\text{s}$  to fill all ten divisions and re-arm. (That is  $25\ \mu\text{s}$  to capture pre-trigger data and  $25\ \mu\text{s}$  to capture post-trigger data.)

## Saving Data from Segmented Memory

You can save either the currently displayed segment (**Save Segment - Current**), or all segments (**Save Segment - All**) in the following data formats: CSV, ASCII XY, and BIN.

Be sure to set the **Length** control to capture enough points to accurately represent the captured data. When the oscilloscope is busy saving multiple segments, progress is displayed.

For more information, see ["To save CSV, ASCII XY, or BIN data files"](#) on page 264.

## Digitizer Mode

Normally, when Digitizer mode is disabled, the oscilloscope's time per division setting determines the sample rate and memory depth so as to fill the waveform display with data while the oscilloscope is running (continuously making acquisitions). For single acquisitions, the time/division setting still determines the sample rate, but the maximum amount of acquisition memory is used.

In Digitizer mode, you choose the desired acquisition sample rate and memory depth, and the time/div setting is adjusted, if necessary, to fill the display with data. The actual sample rate and memory depth used are displayed in the Summary box in the right-side information area.

Digitizer mode primarily aids external software that controls and combines data from multiple instruments.

- To enable and use Digitizer mode**
- 1 Open the Acquire dialog box by selecting the sample rate and memory depth (Acquire) badge or by choosing **Setup > Acquire...** from the main menu.
  - 2 Select **Manual**.

Digitizer mode cannot be used along with these other oscilloscope features: horizontal Zoom display, time references other than Center, segmented memory, serial decode, digital channels, frequency response analysis, and mask test. In most cases, enabling one of these features when Digitizer mode is enabled will automatically disable Digitizer mode, and then disabling the feature will automatically reenable Digitizer mode.

Digitizer mode requires the Normal acquisition mode and real-time sampling (which is the default).

- 3 Select the **Max Sample Rate** field and turn the Entry knob or use the keypad dialog box to enter the desired acquisition sample rate.

The actual sample rate used is displayed at the top of the Acquire dialog box and in the sample rate and memory depth (Acquire) badge.

Only certain sample rates are available. If the sample rate you want is not possible, the next lower available sample rate is used.

- 4 Select the **Max Memory Depth** field and turn the Entry knob or use the keypad dialog box to enter the desired acquisition memory depth.

The actual memory depth used is displayed at the top of the Acquire dialog box and in the sample rate and memory depth (Acquire) badge.



- 5 Press the front panel **[Run]** or **[Single]** keys, or choose **Control > Run/Stop** or **Control > Single**.



# 13 Markers

To make marker measurements / 178

Marker Examples / 181

Markers are horizontal and vertical markers that indicate X-axis values and Y-axis values on a selected waveform source. You can use markers to make custom voltage, time, phase, or ratio measurements on oscilloscope signals.

Marker information is displayed in the Results area.

Markers are not always limited to the visible display. If you set a marker, then pan and zoom the waveform until the marker is off screen, its value will not be changed. It will still be there when you return to its original location.

**X Markers** X markers are vertical dashed lines that adjust horizontally and can be used to measure time (s), frequency (1/s), phase (°), and ratio (%).

When used with the FFT math function as a source, the X markers indicate frequency.

The Markers tab/list in the Results pane shows:

- X1 and X2 marker values for the selected waveform source
- $\Delta X$  (the difference between X1 and X2)
- $1/\Delta X$
- $\Delta Y/\Delta X$

**Y Markers** Y markers are horizontal dashed lines that adjust vertically and can be used to measure Volts or Amps, dependent on the channel **Probe Units** setting, or they can measure ratios (%). When math functions are used as a source, the measurement units correspond to that math function.

The Y markers adjust vertically and typically indicate values relative to the waveform's ground point, except for math FFT where the values are relative to 0 dB.

The Markers tab/list in the Results pane shows:

- Y1 and Y2 marker values for the selected waveform source
- $\Delta Y$  (the difference between Y1 and Y2)

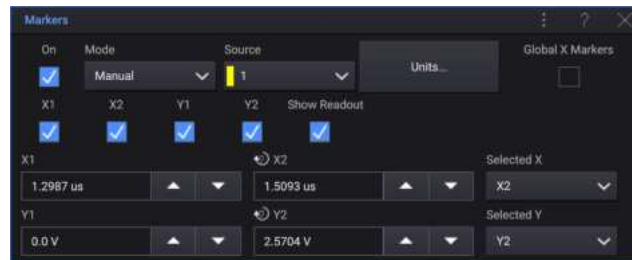
- $\Delta Y/\Delta X$

## To make marker measurements

- 1 Connect a signal to the oscilloscope and obtain a stable display.
- 2 To enable markers:
  - Press the front panel **[Markers]** key to enable or disable markers.
  - Or, in the Markers dialog box, select **On** to enable or disable markers.
- 3 To open the Markers dialog box:
  - Choose **Measure > Markers...** from the main menu.
  - When markers are enabled and displayed in the Results area, select the



Edit button in the Markers window.



- 4 In the Markers dialog box, from the **Mode** drop-down list, you can select:
  - **Manual** –  $\Delta X$ ,  $1/\Delta X$ ,  $\Delta Y$ , and  $\Delta Y/\Delta X$  values are displayed.  $\Delta X$  is the difference between the X1 and X2 markers and  $\Delta Y$  is the difference between the Y1 and Y2 markers.
  - **Track Waveform** – As you move a marker horizontally, the vertical amplitude of the waveform is tracked and measured. The time and voltage positions are shown for the markers. The vertical (Y) and horizontal (X) differences between the markers are shown as  $\Delta X$  and  $\Delta Y$  values.
  - **Measure** – When measurements are displayed, this mode shows the marker locations used to make the measurement. When you add a measurement, it becomes the one that markers are displayed for.

You can change the measurement whose marker locations are displayed by selecting it in the Measurements results list.

- **Binary** – Logic levels of displayed waveforms at the current X1 and X2 marker positions are displayed in the Markers results window in binary. The display is color coded to match the color of the related channel's waveform.
- **Hex** – Logic levels of displayed waveforms at the current X1 and X2 marker positions are displayed in the Markers results window in hexadecimal.

**Manual** and **Track Waveform** modes can be used on waveforms that are displayed on the analog input channels (including math functions).

**Binary** and **Hex** modes apply to digital signals.

In **Hex** and **Binary** modes, a level can be displayed as 1 (higher than trigger level), 0 (lower than trigger level), indeterminate state (-), or X (don't care).

In **Binary** mode, X is displayed if the channel is turned off.

In **Hex** mode, the channel is interpreted as 0 if turned off.

- 5 Select **Source** (or **X1 Source**, **X2 Source** in the **Track Waveform** mode); then, select the input source for marker values.
- 6 Select the **X1**, **X2**, **Y1**, and/or **Y2** check boxes to enable or disable individual markers and the fields used to specify their locations.
- 7 Select the **Show Readout** check box to enable or disable the display of marker value annotations.
- 8 Select the marker(s) to be adjusted:
  - Push the vertical Markers knob to cycle through the selection of **Y1**, **Y2**, or both **Y1 Y2** (to be adjusted as a pair).

You can also make these selections in the Markers dialog box using the **Selected Y** drop-down list.

- Push the horizontal Markers knob to cycle through the selection of **X1**, **X2**, or both **X1 X2** (to be adjusted as a pair).

You can also make these selections in the Markers dialog box using the **Selected X** drop-down list.

Selecting pairs of markers lets you adjust them both at the same time, while the delta value remains the same. This can be useful, for example, for checking pulse width variations in a pulse train.

The currently selected marker(s) are highlighted on the display and in the Markers dialog box.

- 9 Adjust the the selected marker(s):
  - Turn the vertical Markers knob to move the selected marker(s) up or down on the screen.

You can also select the **Y1** and **Y2** fields in the Markers dialog box and use the associated controls to adjust the vertical markers.

- Turn the horizontal Markers knob to move the selected marker(s) left or right on the screen.

You can also select the **X1** and **X2** fields in the Markers dialog box and use the associated controls to adjust the horizontal markers.

You can also select and position markers by dragging them on the touchscreen.

- 10 To change the marker measurement units, select **Units...**

In the Marker Units dialog box:



From the **X Units** drop-down list, you can select:

- **Seconds (s).**
- **Hz (1/s).**
- **Phase (°)** – When selected, select **Use X Markers As 360°** to set the current X1 location as 0 degrees and the current X2 location as 360 degrees.
- **Ratio (%)** – When selected, select **Use X Markers as 100%** to set the current X1 location as 0% and the current X2 location as 100%.

From the **Y Units** drop-down list, you can select:

- **Base** – The Y marker units are the same as used for the source waveform.
- **Ratio (%)** – When selected, select **Use Y Markers as 100%** to set the current Y1 location as 0% and the current Y2 location as 100%.

For phase or ratio units, once the 0 and 360 degree or 0 and 100% locations are set, adjusting markers will display measurements relative to the set locations.

- 11 Select the **Global X Markers** check box to, when there are multiple grids, enable or disable the placement of X markers in all grids. When disabled, X markers appear in the same grid as the source waveform.

## Marker Examples



Figure 33 Markers used to measure pulse widths other than middle threshold points



Figure 34 Markers measure frequency of pulse ringing

Expand the display with Zoom mode, then characterize the event of interest with the markers.



Figure 35 Markers track Zoom window

Put the **X1** marker on one side of a pulse and the **X2** marker on the other side of the pulse.



Figure 36 Measuring pulse width with markers

With **X1 X2** selected, move the markers together to check for pulse width variations in a pulse train.



Figure 37 Moving the markers together to check pulse width variations



# 14 Measurements

To quickly add 10 common measurements / 186

To make automatic measurements / 187

To edit measurements / 188

Measurements Summary / 188

Voltage Measurements / 190

Time Measurements / 196

Count Measurements / 203

Mixed Measurements / 204

FFT Analysis Measurements / 205

Measurement Thresholds / 207

Measurement Window / 209

Measurement Statistics / 209

Measurement Limit Testing / 211

The **Measure** > menu lets you make automatic measurements on waveforms. Some measurements can only be made on analog input channels.

The results of the last 10 selected measurements are displayed in the Measurements window in the Results area.

When you add a measurement, it appears at the bottom of the Measurements list dialog, and markers that show the portion of the waveform being measured are automatically displayed. You can change the measurement for which markers are displayed by selecting the measurement in the list or by selecting the measurement in the Markers dialog box.

## NOTE

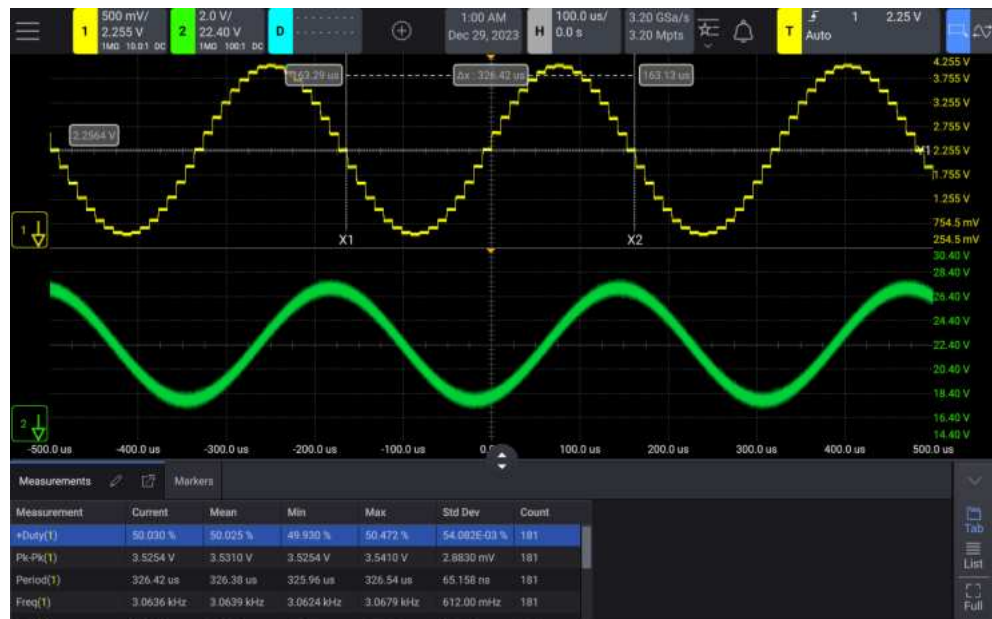
### Post Acquisition Processing

In addition to changing display parameters after the acquisition, you can perform all of the measurements and math functions after the acquisition. Measurements and math functions will be recalculated as you pan and zoom and turn channels on and off. As you zoom in and out on a signal using the horizontal scale knob and vertical volts/division knob, you affect the resolution of the display. Because measurements and math functions are performed on displayed data, you affect the resolution of functions and measurements.

## To quickly add 10 common measurements

- 1 From the menu, choose **Measure > Quick Measure > Channel N**.

Ten common measurements are added for the selected channel and displayed in the Results area.



Statistics are displayed if they are enabled in the **Settings** tab of the Measurements dialog box. See "**Measurement Statistics**" on page 209.

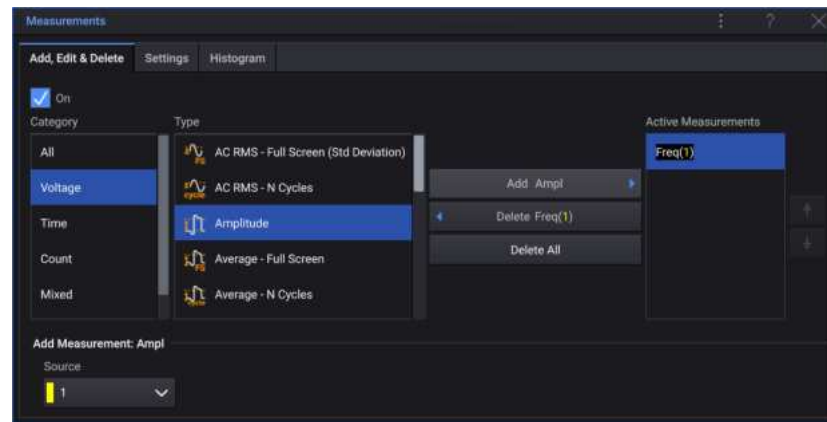
Markers are displayed for a selected measurement to show the portion of the waveform being measured. To view the markers for a different measurement, select it in the Results area.

In the Results area, you can right-click a measurement to:

- Delete the selected measurement.
- Delete all measurements.
- Show or hide statistics.
- Reset statistics.
- Move the measurement up in the list.
- Move the measurement down in the list.

## To make automatic measurements

- 1 From the menu, choose **Measure > Measurements....**
- 2 In the Measurements dialog box, select the **Add, Edit & Delete** tab.



- 3 From the **Type** list, select the measurement you want to add.

To filter the type list, you can select the **Category** of measurements you want to select from:

- **All** – All measurements.
- **Voltage** – Only voltage (vertical) measurements.
- **Time** – Only time (horizontal) measurements.
- **Count** – Only pulse or edge count measurements.
- **Mixed** – Measurements that consider vertical and horizontal values.
- **FFT Analysis** – Measurements for FFT frequency domain waveforms.

For more information on the types of measurements, see "[Measurements Summary](#)" on page 188.

- 4 In the **Add Measurement** area, select the **Source** channel, running math function, or reference waveform being measured.

All measurements have at least one **Source** waveform parameter.

Only channels, math functions, or reference waveforms that are displayed are available for measurements.

### NOTE

If a portion of the waveform required for a measurement is not displayed or does not display enough resolution to make the measurement (approximately 4% of full scale), the result will display "No Edges", "Clipped", "Low Signal" (not enough amplitude), "< value", or "> value", or a similar message to indicate that the measurement may not be reliable.

- 5 Specify any other parameters for the selected measurement.
- 6 Select **Add (measurement)** to add the measurement selected in the **Type** list.

Markers are turned on to show the portion of the waveform being measured for the most recently added measurement (bottom-most on the display). To view the markers for a previously added measurement (but not the last one), select the measurement in the Results area.

By default, measurement statistics are displayed. See "**Measurement Statistics**" on page 209.

- 7 To edit a measurement, select it in the **Active Measurements** list; then select **Edit (measurement)**.
- 8 To show or hide the Measurements window in the Results area, select or clear **On**.
- 9 To delete a measurement, select it in the **Active Measurements** list; then select **Delete (measurement)**.

The measurement is removed from the **Active Measurements** list and from the Results area.

- 10 To delete all measurements, select **Delete All**.

All measurements are removed from the **Active Measurements** list and from the Results area.

## To edit measurements

When added measurements have parameters that can be edited (like the Delay, Phase, Occupied Bandwidth, ACPR, or THD measurements), you can edit the parameters of those measurements.

- 1 From the menu, choose **Measure > Measurements...**
- 2 In the Measurements dialog box, select the **Add, Edit & Delete** tab.
- 3 Select the measurement in the **Active Measurements** list; then select **Edit (measurement)**.

## Measurements Summary

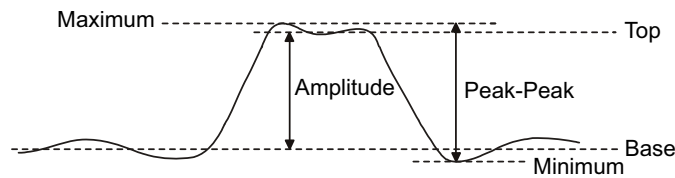
The automatic measurements provided by the oscilloscope are listed in the following table. All measurements are available for analog channel waveforms. All measurements except Counter are available for reference waveforms and math waveforms other than FFT. A limited set of measurements is available for math FFT waveforms and for digital channel waveforms (as described in the following table).

Measurement	Valid for Math FFT*	Valid for Digital Channels	Notes
"Amplitude" on page 191			
"Area" on page 204			
"Average" on page 194	Yes, Full Screen		
"Base" on page 192			
"Bit Rate" on page 199		Yes	
"Burst Width" on page 199			
"Counter" on page 198		Yes	Not valid for math waveforms.
"Delay" on page 200		Yes	Measures between two sources.
"Duty Cycle" on page 199		Yes	
"Fall Time" on page 200			
"Frequency" on page 197		Yes	
"Maximum" on page 191	Yes		
"Minimum" on page 191	Yes		
"Rising Edge Count" on page 204			
"Falling Edges Count" on page 204			
"Positive Pulse Count" on page 203		Yes	
"Negative Pulse Count" on page 203		Yes	
"Overshoot" on page 192			
"Peak-Peak" on page 191	Yes		
"Period" on page 197		Yes	
"Phase" on page 201			Measures between two sources.
"Preshoot" on page 193			
"Ratio" on page 196			Measures between two sources.
"Rise Time" on page 199			
"Slew Rate" on page 205			
"DC RMS" on page 194			

Measurement	Valid for Math FFT*	Valid for Digital Channels	Notes
"AC RMS" on page 195			
"Time at Edge" on page 200		Yes	
"Top" on page 191			
"+ Width" on page 198		Yes	
"- Width" on page 199		Yes	
"X at Max Y" on page 202	Yes		The resultant units are in Hertz.
"X at Min Y" on page 203	Yes		The resultant units are in Hertz.
"Y at X" on page 191	Yes	Yes	With FFT waveforms, X is a frequency value.
* Use the markers to make other measurements on FFT.			

## Voltage Measurements

The following figure shows the voltage measurement points.



Measurement units for each input channel can be set to Volts or Amps using the channel **Probe Units** softkey. See **"To specify the channel units"** on page 61.

The units of math waveforms are described in **"Units for Math Waveforms"** on page 78.

- **"Peak-Peak"** on page 191
- **"Maximum"** on page 191
- **"Minimum"** on page 191
- **"Amplitude"** on page 191
- **"Top"** on page 191
- **"Base"** on page 192
- **"Overshoot"** on page 192
- **"Preshoot"** on page 193

- **"Average"** on page 194
- **"DC RMS"** on page 194
- **"AC RMS"** on page 195
- **"Ratio"** on page 196

## Peak-Peak

The peak-to-peak value is the difference between Maximum and Minimum values. The Y markers show the values being measured.

## Maximum

Maximum is the highest value in the waveform display. The Y marker shows the value being measured.

## Minimum

Minimum is the lowest value in the waveform display. The Y marker shows the value being measured.

## Y at X

**Y at X** measures the vertical value at a specified horizontal location on the specified source waveform. The horizontal location must be on the screen.

When the horizontal axis is time, the horizontal location is a time value referenced to the trigger event.

When the source is an FFT (Fast Fourier Transform) waveform, the horizontal axis is frequency instead of time, and the horizontal location is a frequency value.

## Amplitude

The Amplitude of a waveform is the difference between its Top and Base values. The Y markers show the values being measured.

## Top

The Top of a waveform is the mode (most common value) of the upper part of the waveform, or if the mode is not well defined, the top is the same as Maximum. The Y marker shows the value being measured.

**See Also** • **"To isolate a pulse for Top measurement"** on page 192

### To isolate a pulse for Top measurement

The following figure shows how to use Zoom mode to isolate a pulse for a **Top** measurement.

You may need to change the measurement window setting so that the measurement is made in the lower, Zoom window. See "[Measurement Window](#)" on page 209.



**Figure 38** Isolating area for Top measurement

### Base

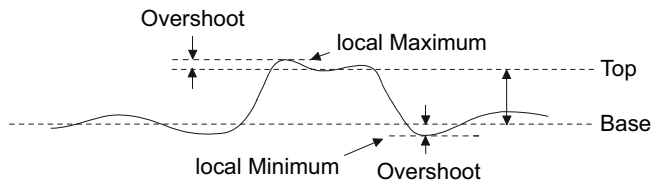
The Base of a waveform is the mode (most common value) of the lower part of the waveform, or if the mode is not well defined, the base is the same as Minimum. The Y marker shows the value being measured.

### Overshoot

Overshoot is distortion that follows a major edge transition expressed as a percentage of Amplitude. The X markers show which edge is being measured (edge closest to the trigger reference point).

$$\text{Rising edge overshoot} = \frac{\text{local Maximum} - D \text{ Top}}{\text{Amplitude}} \times 100$$

$$\text{Falling edge overshoot} = \frac{\text{Base} - \text{D local Minimum}}{\text{Amplitude}} \times 100$$



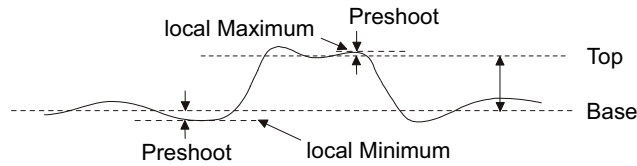
**Figure 39** Automatic Overshoot measurement

## Preshoot

Preshoot is distortion that precedes a major edge transition expressed as a percentage of Amplitude. The X markers show which edge is being measured (edge closest to the trigger reference point).

$$\text{Rising edge preshoot} = \frac{\text{local Maximum} - \text{D Top}}{\text{Amplitude}} \times 100$$

$$\text{Falling edge preshoot} = \frac{\text{Base} - \text{D local Minimum}}{\text{Amplitude}} \times 100$$



## Average

Average is the sum of the levels of the waveform samples divided by the number of samples.

$$Average = \frac{\sum x_i}{n}$$

Where  $x_i$  = value at  $i$ th point being measured,  $n$  = number of points in measurement interval.

The Full Screen measurement interval variation measures the value on all displayed data points.

The N Cycles measurement interval variation measures the value on an integral number of periods of the displayed signal. If less than three edges are present, the measurement shows "No edges".

The X markers show what interval of the waveform is being measured.

## DC RMS

DC RMS is the root-mean-square value of the waveform over one or more full periods.

$$RMS (dc) = \sqrt{\frac{\sum_{i=1}^n x_i^2}{n}}$$

Where  $x_i$  = value at  $i$ th point being measured,  $n$  = number of points in measurement interval.

The Full Screen measurement interval variation measures the value on all displayed data points.

The N Cycles measurement interval variation measures the value on an integral number of periods of the displayed signal. If less than three edges are present, the measurement shows "No edges".

The X markers show the interval of the waveform being measured.

## AC RMS

AC RMS is the root-mean-square value of the waveform, with the DC component removed. It is useful, for example, for measuring power supply noise.

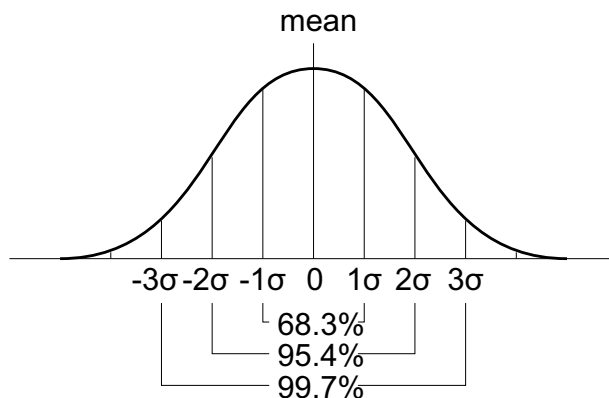
The N Cycles measurement interval measures the value on an integral number of periods of the displayed signal. If less than three edges are present, the measurement shows "No edges".

The X markers show the interval of the waveform being measured.

The Full Screen (Std Deviation) measurement interval variation is an RMS measurement across the full screen with the DC component removed. It shows the standard deviation of the displayed voltage values.

The standard deviation of a measurement is the amount that a measurement varies from the mean value. The Mean value of a measurement is the statistical average of the measurement.

The following figure graphically shows the mean and standard deviation. Standard deviation is represented by the Greek letter sigma:  $\sigma$ . For a Gaussian distribution, two sigma ( $\pm 1\sigma$ ) from the mean, is where 68.3 percent of the measurement results reside. Six sigma ( $\pm 3\sigma$ ) from is where 99.7 percent of the measurement results reside.



The mean is calculated as follows:

$$\bar{x} = \frac{\sum_{i=1}^N x_i}{N}$$

where:

- $x$  = the mean.
- $N$  = the number of measurements taken.
- $x_i$  = the  $i$ th measurement result.

The standard deviation is calculated as follows:

$$\sigma = \sqrt{\frac{\sum_{i=1}^N (x_i - \bar{x})^2}{N}}$$

where:

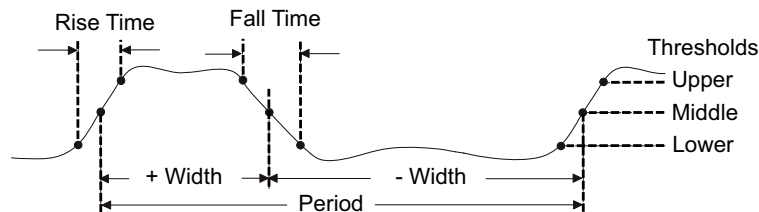
- $\sigma$  = the standard deviation.
- $N$  = the number of measurements taken.
- $x_i$  = the  $i$ th measurement result.
- $\bar{x}$  = the mean.

## Ratio

The Ratio measurement displays the ratio of the AC RMS voltages of two sources, expressed in dB. Use the **Source 1** and **Source 2** drop-down lists to select the source channels for the measurement.

## Time Measurements

The following figure shows time measurement points.



The default lower, middle, and upper measurement thresholds are 10%, 50%, and 90% between Top and Base values. See "**Measurement Thresholds**" on page 207 for other percentage threshold and absolute value threshold settings.

- "**Period**" on page 197
- "**Frequency**" on page 197
- "**Counter**" on page 198
- "**+ Width**" on page 198
- "**- Width**" on page 199
- "**Burst Width**" on page 199
- "**Duty Cycle**" on page 199
- "**Bit Rate**" on page 199

- **"Rise Time"** on page 199
- **"Fall Time"** on page 200
- **"Delay"** on page 200
- **"Phase"** on page 201
- **"X at Max Y"** on page 202
- **"X at Min Y"** on page 203

## Period

Period is the time period of the complete waveform cycle. The time is measured between the middle threshold points of two consecutive, like-polarity edges. A middle threshold crossing must also travel through the lower and upper threshold levels which eliminates runt pulses. The X markers show what portion of the waveform is being measured. The Y marker shows the middle threshold point.

## Frequency

Frequency is defined as  $1/\text{Period}$ . Period is defined as the time between the middle threshold crossings of two consecutive, like-polarity edges. A middle threshold crossing must also travel through the lower and upper threshold levels which eliminates runt pulses. The X markers show what portion of the waveform is being measured. The Y marker shows the middle threshold point.

- See Also**
- **"To isolate an event for frequency measurement"** on page 197

### To isolate an event for frequency measurement

The following figure shows how to use Zoom mode to isolate an event for a frequency measurement.

You may need to change the measurement window setting so that the measurement is made in the lower, Zoom window. See **"Measurement Window"** on page 209.

If the waveform is clipped, it may not be possible to make the measurement.



**Figure 40** Isolating an event for Frequency measurement

## Counter

The InfiniiVision HD3-Series oscilloscopes have an integrated hardware frequency counter which counts the number of cycles that occur within a period of time (known as the gate time) to measure the frequency of a signal.

The gate time is the horizontal range of the oscilloscope but is limited to  $\geq 0.1$  s and  $\leq 10$  s. Unlike other measurements, the Zoom horizontal timebase window does not gate the Counter measurement.

The Counter measurement can measure frequencies up to the bandwidth of the oscilloscope. The minimum frequency supported is  $2.0 / \text{gateTime}$ .

The hardware counter uses the trigger comparator output. Therefore, the counted channel's trigger level (or threshold for digital channels) must be set correctly.

Analog and digital channels can be selected as the source.

Only one Counter measurement can be displayed at a time.

## + Width

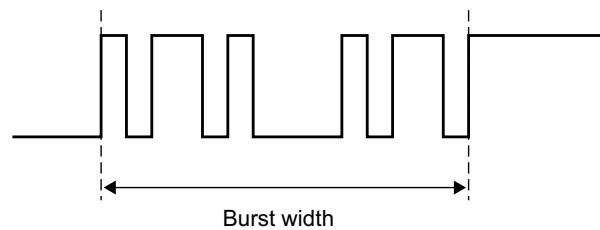
**+ Width** is the time from the middle threshold of the rising edge to the middle threshold of the next falling edge. The X markers show the pulse being measured. The Y marker shows the middle threshold point.

## – Width

– **Width** is the time from the middle threshold of the falling edge to the middle threshold of the next rising edge. The X markers show the pulse being measured. The Y marker shows the middle threshold point.

## Burst Width

The Burst Width measurement is the time from the first edge to the last edge on screen.



## Duty Cycle

The duty cycle of a repetitive pulse train is the ratio of the pulse width to the period, expressed as a percentage. The X markers show the time period being measured. The Y marker shows the middle threshold point.

$$+ \text{Duty cycle} = \frac{+ \text{Width}}{\text{Period}} \times 100 \quad - \text{Duty cycle} = \frac{- \text{Width}}{\text{Period}} \times 100$$

## Bit Rate

The bit rate measurement measures all positive and negative pulse widths on the waveform, takes the minimum value found of either width type and inverts that minimum width to give a value in Hertz.

## Rise Time

The rise time of a signal is the time difference between the crossing of the lower threshold and the crossing of the upper threshold for a positive-going edge. The X marker shows the edge being measured. For maximum measurement accuracy, set the horizontal time/div as fast as possible while leaving the complete rising edge of the waveform on the display. The Y markers show the lower and upper threshold points.

## Fall Time

The fall time of a signal is the time difference between the crossing of the upper threshold and the crossing of the lower threshold for a negative-going edge. The X marker shows the edge being measured. For maximum measurement accuracy, set the horizontal time/div as fast as possible while leaving the complete falling edge of the waveform on the display. The Y markers show the lower and upper threshold points.

## Time at Edge

**Time at Edge** measures the horizontal time of the edge location specified by the **Source**, **Slope**, and **Edge #** parameters.

The threshold voltage used for this measurement is the 50% point with a small amount of hysteresis added. (The "middle" measurement threshold setting for the source waveform does not affect this measurement.)

When the specified slope and edge number threshold crossing is found, the oscilloscope reports the time of that crossing in seconds, with the trigger point (time=zero) as the reference.

If the specified crossing cannot be found, that is, if the waveform does not cross the 50% vertical value, or if the waveform does not cross the 50% vertical value for the specific number of times at the slope specified, the oscilloscope reports "**No edges**".

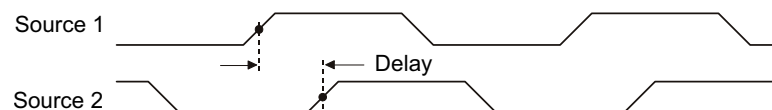
When **Auto** is selected as the **Edge #**, the edge closest to the timebase reference point is used. When you specify an edge number, edges are counted from the left side of the display.

FFT (Fast Fourier Transform) waveforms cannot be selected as the source.

## Delay

Delay measures the time difference between two waveform edges using the specified threshold points of the waveforms.

Negative delay values indicate that the selected edge of source 1 occurred after the selected edge of source 2.



- 1 From the menu, choose **Measure > Measurements...**
- 2 In the Measurements dialog box, select the **Add, Edit & Delete** tab.
- 3 From the **Type** list, select the **Delay** measurement.

4 In the **Add Parameter** area, select:

- **Source 1, Source 2** – Waveform sources.
- **Source 1 Slope, Source 2 Slope** – Rising edge or falling edge on.
- **Auto** – Uncheck so that edge numbers can be specified.
- **Source 1 Edge #, Source 2 Edge #** – Edge number for the selected source.

When **Auto** is selected for the **Source 1 Edge #**, the edge closest to the timebase reference point is used. **Auto** is also automatically selected for the **Source 2 Edge #**, and cannot be changed. In this case, the source 2 edge closest to the source 1 edge is used.

When edge numbers are selected, edges are counted from the left side of the display for both sources.

- **Source 1 Threshold, Source 2 Threshold** – Specifies whether the measurement should be made using the **Upper, Middle, or Lower** threshold level on the source.

5 Select **Add Delay** to activate the measurement.

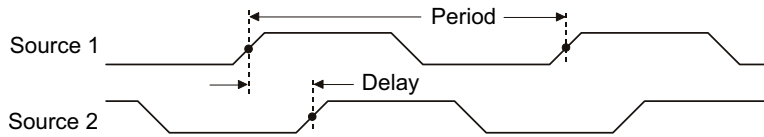
The example below shows a delay measurement between the rising edge of channel 1 and the rising edge of channel 2.



## Phase

Phase is the calculated phase shift from source 1 to source 2, expressed in degrees. Negative phase shift values indicate that the rising edge of source 1 occurred after the rising edge of source 2.

$$\text{Phase} = \frac{\text{Delay}}{\text{Source 1 Period}} \times 360$$



- 1 From the menu, choose **Measure > Measurements...**
- 2 In the Measurements dialog box, select the **Add, Edit & Delete** tab.
- 3 From the **Type** list, select the **Phase** measurement.
- 4 In the **Add Parameter** area, select:
  - **Source 1, Source 2** – Waveform sources.
- 5 Select **Add Phase** to activate the measurement.

The example below shows a phase measurement between the channel 1 and the math d/dt function on channel 1.



### X at Max Y

X at Max Y is the X axis value (usually time) at the first displayed occurrence of the waveform Maximum, starting from the left-side of the display. For periodic signals, the position of the maximum may vary throughout the waveform. The X marker shows where the current X at Max Y value is being measured.

See Also · ["To measure the peak of an FFT"](#) on page 203

### To measure the peak of an FFT

- 1 Select **FFT** as the Operator in the Waveform Math Menu.
- 2 Choose **Math N** as the source in the Measurement Menu.
- 3 Choose **Maximum** and **X at Max Y** measurements.

**Maximum** units are in dB and **X at Max Y** units are in Hertz for FFT.

### X at Min Y

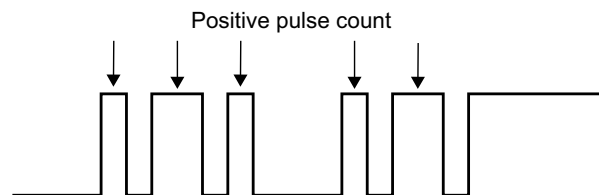
X at Min Y is the X axis value (usually time) at the first displayed occurrence of the waveform Minimum, starting from the left-side of the display. For periodic signals, the position of the minimum may vary throughout the waveform. The X marker shows where the current X at Min Y value is being measured.

## Count Measurements

- ["Positive Pulse Count"](#) on page 203
- ["Negative Pulse Count"](#) on page 203
- ["Rising Edge Count"](#) on page 204
- ["Falling Edges Count"](#) on page 204

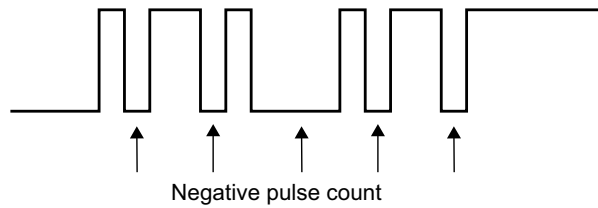
### Positive Pulse Count

The **Positive Pulse Count** measurement is a pulse count for the selected waveform source.



### Negative Pulse Count

The **Negative Pulse Count** measurement is a pulse count for the selected waveform source.



### Rising Edge Count

The **Rising Edge Count** measurement is an edge count for the selected waveform source.

This measurement is available for analog channels.

### Falling Edges Count

The **Falling Edges Count** measurement is an edge count for the selected waveform source.

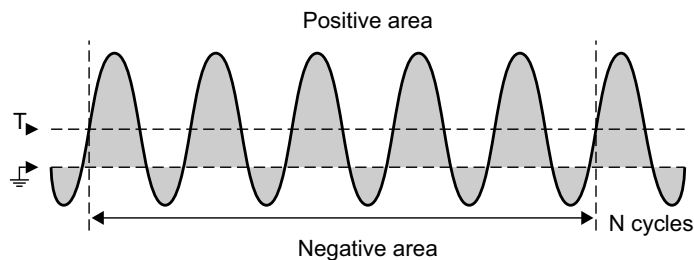
This measurement is available for analog channels.

### Mixed Measurements

- **"Area"** on page 204

### Area

Area measures the area between the waveform and the ground level. Area below the ground level is subtracted from area above the ground level.



The Full Screen measurement interval variation measures the value on all displayed data points.

The N Cycles measurement interval variation measures the value on an integral number of periods of the displayed signal. If less than three edges are present, the measurement shows "No edges".

The X markers show what interval of the waveform is being measured.

## Slew Rate

**Slew Rate** measures the change in vertical value ( $\Delta Y$ ) divided by the change in horizontal value ( $\Delta X$ ) for the edge closest to the timebase reference point specified by the **Source** and **Slope** parameters.

The lower and upper thresholds for the measurement are specified by the measurement threshold setting for the source waveform.

FFT (Fast Fourier Transform) waveforms cannot be selected as the source.

## FFT Analysis Measurements

- **"Channel Power"** on page 205
- **"Occupied Bandwidth"** on page 205
- **"Adjacent Channel Power Ratio (ACPR)"** on page 206
- **"Total Harmonic Distortion (THD)"** on page 206

## Channel Power

**Channel Power** measures the spectral power across a frequency range.

The center frequency used in the measurement is the one defined for the FFT function, and the FFT span specifies the frequency range.

When this measurement is tracked with markers, the markers are at the far left and right edges of the graticule.

## Occupied Bandwidth

**Occupied Bandwidth** measures the bandwidth (frequency range) containing some percent (usually 99%) of the total spectral power. While 99% is the industry norm, you can specify the percent you want to use in the measurement.

The center frequency used in the measurement is the one defined for the FFT function, and the FFT span represents the total spectral power.

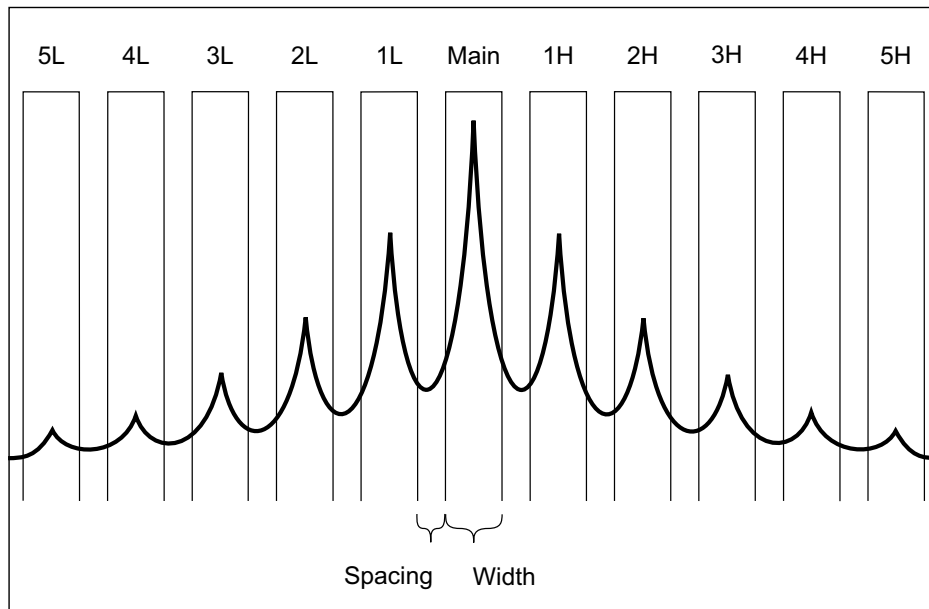
When this measurement is tracked with markers, the markers show the measured bandwidth (frequency range).

## Adjacent Channel Power Ratio (ACPR)

Adjacent Channel Power Ratio or just **Adjacent Power Ratio** (or channel leakage ratio) measures the ratio of the power contained in one or more sidebands to the power in the main frequency range.

The main range is specified by a channel width and a center frequency. The Channel Width is one of the measurement's parameters. The center frequency used in the measurement is the one defined for the FFT function.

Sidebands (with the same width as the main range) exist above and below the main range separated by the channel spacing width. The Channel Spacing width is another measurement parameter.



The sideband used for the measurement is selected with the Channel Select parameter. You can select the first through fifth sidebands above or below the main range (1H through 5H above and 1L through 5L below). The full sideband must be in the graticule to be measured. Otherwise, the measurement results will be "Incomplete".

When this measurement is tracked with markers, the markers show the sideband being measured.

## Total Harmonic Distortion (THD)

**Total Harmonic Distortion** (THD) is the ratio of power in the fundamental frequency to the power contained in the rest of the harmonics and noise. THD is a measure of signal purity.

**Total Harmonic Distortion (THD)** measures the power contained in the bands surrounding each harmonic and compares it to the power in the band surrounding the fundamental frequency. The width of the bands measured is the same for the fundamental frequency and each harmonic. That width is 1/2 of the fundamental frequency.

You can either enter the fundamental frequency as a measurement parameter and have the fundamental frequency and harmonics be tracked manually, or you can allow the fundamental frequency and harmonics to be tracked automatically, where the highest peak is assumed to be the fundamental frequency.

When this measurement is tracked with markers, the markers show the band surrounding the fundamental frequency that is being measured (at  $\pm 1/4$  of the fundamental frequency).

## Measurement Thresholds

Setting measurement thresholds defines the vertical levels where measurements will be taken on an analog channel or math waveform.

### NOTE

#### Changing default thresholds may change measurement results

The default lower, middle, and upper threshold values are 10%, 50%, and 90% of the value between Top and Base. Changing these threshold definitions from the default values may change the returned measurement results for Average, Delay, Duty Cycle, Fall Time, Frequency, Overshoot, Period, Phase, Preshoot, Rise Time, +Width, and -Width.

- 1 From the menu, choose **Measure > Measurements...**
- 2 In the Measurements dialog box, select the **Settings** tab.
- 3 Select **Thresholds...**
- 4 In the Measurement Thresholds dialog box:



- There are tabs for **Channels**, **Math**, and **Reference** waveforms.

Each analog channel, math function, and reference waveform can be assigned unique threshold values.

- In the **Type** column, select:
  - **Percent** – To set the measurement threshold as a % (percentage) of the Top and Base values.  
Percentage thresholds can be set from 0% to 100%.
  - **Absolute** – To set the measurement threshold as an absolute value.  
The units for absolute threshold for each channel is set in the channel probe dialog box.

**TIP****Absolute threshold hints**

- Absolute thresholds are dependent on channel scaling, probe attenuation, and probe units. Always set these values first before setting absolute thresholds.
- The minimum and maximum threshold values are limited to on-screen values.
- If any of the absolute threshold values are above or below the minimum or maximum waveform values, the measurement may not be valid.

- In the **Lower** column, select the field and enter the lower measurement threshold value.

Increasing the lower value beyond the set middle value will automatically increase the middle value to be more than the lower value. The default lower threshold is 10% or 800 mV.

If threshold **Type** is set to %, the lower threshold value can be set from 0% to 98%.

- In the **Middle** column, select the field and enter the middle measurement threshold value.

The middle value is bounded by the values set for lower and upper thresholds. The default middle threshold is 50% or 1.20 V.

If threshold **Type** is set to %, the middle threshold value can be set from 1% to 99%.

- In the **Upper** column, select the field and enter the upper measurement threshold value.

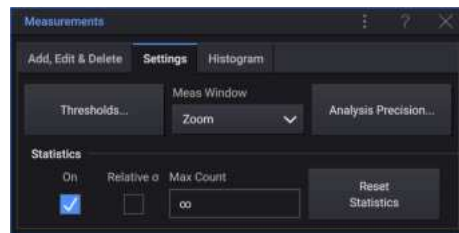
Decreasing the upper value below the set middle value will automatically decrease the middle value to be less than the upper value. The default upper threshold is 90% or 1.50 V.

If threshold **Type** is set to %, the upper threshold value can be set from 2% to 100%.

## Measurement Window

You can choose whether measurements are made in the Main window portion of the display, the Zoom window portion of the display (when the zoomed time base is displayed), or gated by the X1 and X2 markers.

- 1 From the menu, choose **Measure > Measurements...**
- 2 In the Measurements dialog box, select the **Settings** tab.



- 3 From the **Meas Window** drop-down list, you can select:
  - **Auto Select** – When the zoomed time base is displayed, the measurement is attempted in the zoomed time base window; if it cannot be made there, or if the zoomed time base is not displayed, the Main window is used.
  - **Main** – The measurement window is the Main window.
  - **Zoom** – The measurement window is the zoomed time base window.
  - **Gated by Markers** – The measurement window is between the X1 and X2 markers. When the zoomed time base is displayed, the X1 and X2 markers in the Zoom window portion of the display are used.

## Measurement Statistics

To display measurement statistics:

- 1 From the menu, choose **Measure > Measurements...**
- 2 In the Measurements dialog box, select the **Settings** tab.
- 3 In the Statistics area, select **On** to enable or disable the display of measurement statistics.

When enabled, measurement statistics appear in the Measurements window in the Results pane.



The source channel of the measurement is shown in parenthesis after the measurement name. For example: "**Freq(1)**" indicates a frequency measurement on channel 1.

The following statistics are shown: Name of the measurement, current measured value, mean, minimum measured value, maximum measured value, standard deviation, and the number of times the measurement has been made (count). Statistics are based on the total number of captured waveforms (count).

The standard deviation shown in Statistics is calculated using the same formula used for calculating the standard deviation measurement. The formula is shown in the section titled "**AC RMS**" on page 195.

Statistics continue to accumulate even when the statistics display is disabled.

- 4 To reset the statistics measurements, select **Reset Statistics**. This resets all statistics and begins recording statistical data again.

Each time a new measurement (for example: frequency, period, or amplitude) is added the statistics are reset and accumulation of statistical data begins again.

- 5 To enable or disable a relative standard deviation, select **Relative  $\sigma$** .

When enabled, the standard deviation shown in measurement statistics becomes the standard deviation/mean.

- 6 To specify the number of values used when calculating measurement statistics, select the **Max Count** field and enter the desired value.

Statistics are calculated on the most recent "N" number of values, where N is either the total number of acquisitions measured or a limited **Max Count** number of acquisitions measured.

Other things to know about measurement statistics:

- When the **[Single]** key is pressed, statistics are reset and a single measurement is done (count = 1). Successive **[Single]** acquisitions accumulate statistical data (and the count is incremented).

## Measurement Limit Testing

Measurement limit testing lets you test measurement values to see whether they are inside or outside specified limits. You can display limit test results, and you can stop running oscilloscope acquisitions when there is a failure. You can specify whether measured values inside the limits or outside the limits are considered failures.

To enable measurement limit testing and add measurements to the limit test, specify limits, and specify whether failures are inside or outside the limits:

- 1 First, add the measurements whose limits you want to test.

In the Limit Test dialog box (opened in the next step), if measurements have not already been added, there is a **Measurements...** button that opens the Measurements dialog box where you can add, edit, and delete measurements, specify measurement thresholds, specify the measurement window, display measurement statistics, and display measurement histograms.

- 2 From the main menu, choose **Measure > Limit Test...**
- 3 In the Limit Test dialog box, select **On** to enable or disable limit testing.

Measurement limit results are reset whenever Measurement Limit Test is re-enabled.

- 4 Active measurements whose limits can be tested appear in the **Measurement** column. Select a measurement to enable or disable it in the limit test.
- 5 Use the drop-down list in the **Fail When** column to select whether values **Outside Limits** or **Inside Limits** are considered failures.
- 6 Specify the measurement limits:
  - To directly enter measurement limits, select the **Lower Limit** and **Upper Limit** fields, and enter the values.
  - To create measurement limits from the last measured value plus or minus a percent margin, select the field in the **Copy Margin** column and enter the percent margin. Then, select the **Copy** button in the **Copy From Results** column.

Limit test results are displayed with measurement statistics (which are forced on).



Added to the usual measurement statistics are columns for:

- The number of failures on the lower limit (**Fail Min**)
- The number of failures on the upper limit (**Fail Max**)

To stop running acquisitions when there are measurement limit test failures, select **Stop On Failure**.

To reset all measurement statistics and begins recording statistical data again, select **Reset Statistics**.

# 15 Histogram

Waveform Histogram Set Up / 214

Measurement Histogram Set Up / 217

Histogram Data Graph / 218

Histogram Data Statistics / 219

The histogram analysis feature provides a statistical view of a waveform or a measurement's results.

Waveform histograms show the number of times a waveform crosses into (or hits) a row or column of a user-defined window. For vertical histograms, the window is divided into rows. For horizontal histograms, the window is divided into columns.

Measurement histograms show the distribution of a measurement's results similar to ordinary measurement statistics.

As waveforms are acquired and displayed, or as measurements are made, a counter database accumulates the total number of hits (or measurements), and the histogram data is displayed as a bar graph on the graticule.

When the oscilloscope is stopped, that counter database remains intact until the acquired data display is modified, usually horizontally or vertically. At that time, the database is reset and the last displayed acquisition is used to start a new database.

Histogram results statistics are displayed in the Histogram results window.

The following screen shows a horizontal histogram looking at edge times:



### Histogram Interaction With Other Oscilloscope Features

When you enable a histogram, horizontal zoom is automatically disabled.

When using segmented memory acquisitions, histograms perform similarly to math waveforms and measurements. The histogram is reset at the start of a segmented acquisition and all segments are histogrammed at the end of the acquisition.

Because it is not possible to histogram every waveform, be aware that persistence can show a peak or glitch that does not show up in the histogram data.


Histograms do not wait for the specified number of averaged acquisitions to be acquired before starting analysis, so intermediate results could be erratic.

## Waveform Histogram Set Up

To set up a waveform histogram:

- 1 Turn on histogram analysis.

A quick way to do this is by drawing a rectangle:

- a Touch the upper-right corner to select the  draw box mode.
- b Drag your finger (or connected USB mouse pointer) across the screen to draw a rectangular over the waveform you want to histogram.
- c Take your finger off the screen (or release the mouse button).
- d In the pop-up menu, select **Histogram**.

The Histogram dialog box opens with **On** selected, and the rectangle you drew becomes the limits window.

Or, you can:

- a From the menu, choose **Analyze > Histogram...**
  - b In the Histogram dialog box, select **On**.
- 2 From the **Type** drop-down list, you can select:
    - **Horizontal** – The limits window is divided into columns, and the number of hits in each column is displayed in a histogram bar graph at the bottom of the graticule.
    - **Vertical** – The limits window is divided into rows, and the number of hits in each row is displayed in a histogram bar graph at the left of the graticule.
  - 3 From the **Source** drop-down list, you can select the analog channel, running math function, or reference waveform to analyze.
  - 4 Define the limits window in which waveform crossings (hits) are measured. See "[Defining the Histogram Limits Window](#)" on page 216.
  - 5 In the **Histogram Size** field, specify the number of divisions the histogram bar graph should use:
    - For horizontal histograms, you can choose whole and half divisions from 1 to 4.
    - For vertical histograms, you can choose whole and half divisions from 1 to 5.

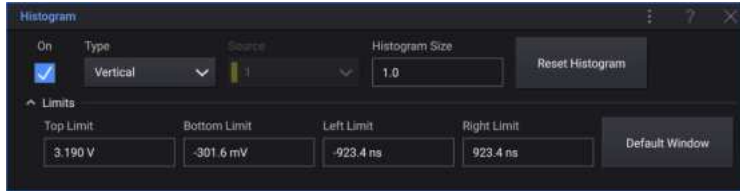
You can select **Reset Histogram** to zero the histogram counters.


The following screen shows a vertical histogram:



## Defining the Histogram Limits Window

You can define the histogram limits window using the **Limits** area controls in the Histogram dialog box.



Use the **Top Limit**, **Bottom Limit**, **Left Limit**, and **Right Limit** fields to define the limits window in which waveform crossings (hits) measured. Selecting the field name lets you use the Entry knob  to adjust the field value.

Select **Default Window** to set up a limits window that is six divisions tall and eight divisions wide, centered on the graticule.

You can also define the histogram limits window using the touchscreen. When you select the limits window, you can drag it on the screen.



The lower right corner touch handle changes the size of the window.

The upper right corner edit (pencil) icon opens the Histogram dialog box.

## Measurement Histogram Set Up

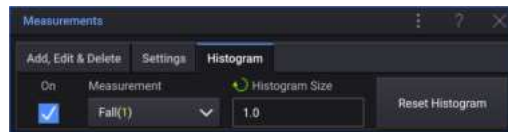
Measurement histograms show the distribution of a measurement's results similar to ordinary measurement statistics.

To set up a measurement histogram:

- 1 First, add the measurement whose results you want to display as a histogram. See "[To make automatic measurements](#)" on page 187.
- 2 Turn on measurement histogram analysis.

You can:

- a From the menu, choose **Measure > Measurements...**
- b In the Measurements dialog box, select the **Histogram** tab.



Or, you can:

- a From the menu, choose **Analyze > Histogram....**
- b In the Histogram dialog box, select **On**.
- c From the **Type** drop-down list, select **Measurements**.
- 3 From the **Measurement** drop-down list, select the measurement to analyze.
- 4 In the **Histogram Size** field, specify the number of divisions the histogram bar graph should use. You can choose whole and half divisions from 1 to 4.

For measurement histograms, information about the scale of the bar graph appears in the grid. This scale is automatically determined.

You can select **Reset Histogram** to zero the histogram counters.



## Histogram Data Graph

The visual component of a histogram is the bar graph on the display.

This graph appears on the left side of the graticule area for a vertical waveform histogram or on the graticule bottom for a horizontal waveform histogram or a measurement histogram.

For measurement histograms, information about the scale of the bar graph appears in the grid. This scale is automatically determined.

As waveforms are acquired and displayed, or as measurements are made, the bar graph scale changes so that the peak number of hits is displayed at the histogram size specified.

The **Reset Histogram** button zeros the histogram counters.

### Markers on Histogram Data

When the histogram analysis feature is enabled and when markers are in **Manual** or **Track Waveform** mode, **Histogram** is added to the list of sources you can select for markers.

If you are doing a measurement on a histogram, markers track that measurement on the histogram waveform.

When markers are in the **Track Waveform** mode, the X or the Y marker is moveable depending on whether the histogram type is horizontal, vertical, or measurement.

## Histogram Data Statistics

Histogram data results appear in the Histogram window in the Results pane.

There are several standard results that can be derived from the histogram database.

The basic units of histograms are hits, and there are some results that are expressed as hits:

- Hits – The sum of all bins (buckets) in the histogram.
- Peak – Maximum number of hits in any single bin.

Some results are expressed in the source's (vertical, horizontal or measurement) units:

- Max – The value corresponding to the maximum bin that has any hits.
- Min – The value corresponding to the minimum bin that has any hits.
- Pk-Pk – Delta between the Max and Min.
- Mean – Mean of the histogram.
- Median – Median of the histogram.
- Mode – Mode of the histogram.
- Bin Width – The width of each bin (bucket) in the histogram.
- Std Dev – Standard deviation of the histogram.

Some results are derived from other results:

- $\mu \pm 1\sigma$  – Percentage of histogram hits that lie within  $\pm 1$  Std Dev of the mean.
- $\mu \pm 2\sigma$  – Percentage of histogram hits that lie within  $\pm 2$  Std Dev of the mean.
- $\mu \pm 3\sigma$  – Percentage of histogram hits that lie within  $\pm 3$  Std Dev of the mean.

In the Histogram results window, you can select the edit (pencil) icon to open the Histogram dialog box.



# 16 Mask Testing

To create a mask from a "golden" waveform (Automask) / 221

Mask Test Setup Options / 223

Mask Statistics / 225

To manually modify a mask file / 226

Building a Mask File / 229

One way to verify a waveform's compliance to a particular set of parameters is to use mask testing. A mask defines a region of the oscilloscope's display in which the waveform must remain in order to comply with chosen parameters. Compliance to the mask is verified point-by-point across the display. Mask test operates on displayed analog channels; it does not operate on channels that are not displayed.

Mask test is included as a standard feature.

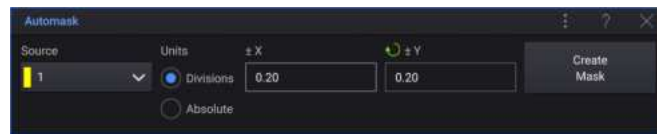
## To create a mask from a "golden" waveform (Automask)

A golden waveform meets all chosen parameters, and it is the waveform to which all others will be compared.

- 1 Configure the oscilloscope to display the golden waveform.
- 2 From the main menu, choose **Analyze > Mask Test...**
- 3 In the Mask Test dialog box, select **On** to enable mask testing.



- 4 Select **Automask...**
- 5 In the Automask dialog box, from the **Source** drop-down list, select the analog channel to test.




- 6 Adjust the mask's horizontal tolerance ( $\pm Y$ ) and vertical tolerance ( $\pm X$ ). These are adjustable in graticule divisions or in absolute units (volts or seconds), selectable using the **Units** option.
- 7 Select **Create Mask**.

The mask is created and testing begins.

Whenever **Create Mask** is selected, the old mask is erased and a new mask is created.



- 8 To clear the mask and switch off mask testing, in the Mask Test results window,

select the  Edit (pencil) icon button to open the Mask Test dialog box. Then select **Clear Mask**.

If infinite persistence display mode (see "**To set or clear persistence**" on page 124) is "on" when mask test is enabled, it stays on. If infinite persistence is "off" when mask test is enabled, it is switched on when mask test is switched on, then infinite persistence is switched off when mask test is switched off.

#### Troubleshooting Mask Setup

If you select **Create Mask** and the mask appears to cover the entire screen, check the  $\pm Y$  and  $\pm X$  settings in the Automask dialog box. If these are set to zero the resulting mask will be extremely tight around the waveform.

If you select **Create Mask** and it appears that no mask was created, check the  $\pm Y$  and  $\pm X$  settings. They may be set so large that the mask is not visible.

## Mask Test Setup Options

In the **Setup** area of the Mask Test dialog box, you can select these options:

<b>Run Until</b>	<p>The <b>Run Until</b> drop-down list lets you specify a condition on which to terminate testing.</p> <ul style="list-style-type: none"> <li>▪ <b>Forever</b> – The oscilloscope runs continuously. However, if an error occurs, the <b>On Error</b> action(s) will occur.</li> <li>▪ <b>Minimum # of Tests</b> – Choose this option and then use the <b># of Tests</b> field to enter the number of times the oscilloscope will trigger, display the waveform(s), and compare them to the mask. The oscilloscope will stop after the specified number of tests have been completed. The specified minimum number of tests may be exceeded. If an error occurs, the <b>On Error</b> action(s) will occur. The actual number of tests completed is displayed in the Mask Test results window.</li> <li>▪ <b>Minimum Time</b> – Choose this option and then use the <b>Test Time</b> field to enter how long the oscilloscope will run. When the selected time has passed the oscilloscope will stop. The specified time may be exceeded. If an error occurs, the <b>On Error</b> action(s) will occur. The actual test time is displayed in the Mask Test results window.</li> <li>▪ <b>Minimum Sigma</b> – Choose this option and then use the <b>Sigma</b> field to enter a minimum sigma. The mask test runs until enough waveforms are tested to achieve a minimum test sigma. (If an error occurs, the <b>On Error</b> action(s) will occur.)</li> </ul> <p>Note that this is a test sigma (the max achievable process sigma, assuming no defects, for a certain number of tested waveforms) as opposed to a process sigma (which is tied to the amount of failures per test). The sigma value may exceed the selected value when a small sigma value is chosen. The actual sigma is displayed.</p>
<b>On Error</b>	<p>The <b>On Error</b> options specify the action(s) to take when the input waveform does not conform to the mask. This setting supersedes the <b>Run Until</b> setting.</p> <ul style="list-style-type: none"> <li>▪ <b>Stop</b> – The oscilloscope will stop when the first error is detected (on the first waveform that does not conform to the mask). This setting supersedes the <b>Minimum # of Tests</b> and <b>Minimum Time</b> settings.</li> <li>▪ <b>Save</b> – The oscilloscope saves the screen image when an error is detected. In the Save dialog box (choose <b>File &gt; Save...</b>), select an image format (*.bmp or *.png), destination (on a USB storage device), and file name (which can be auto-incrementing). If errors occur too frequently and the oscilloscope spends all its time saving images, press the <b>[Stop]</b> key to stop acquisitions.</li> <li>▪ <b>Meas</b> – Measurements and measurement statistics run only on waveforms that contain a mask violation. Measurements are not affected by passing waveforms. This mode is not available when the acquisition mode is set to <b>Averaging</b>.</li> </ul> <p>Note that you can choose to <b>Print</b> or <b>Save</b>, but you cannot select both at the same time. All other actions may be selected at the same time. For example, you can select both <b>Stop</b> and <b>Meas</b> to cause the oscilloscope to measure and stop on the first error..</p> <p>You can also output a signal on the rear panel AUX OUT BNC connector when there is a mask test failure. See "<b>Setting the Rear Panel AUX OUT Source</b>" on page 282.</p>

<b>Source Lock</b>	<p>When you turn on <b>Source Lock</b>, the mask is redrawn to match the source whenever you move the waveform. For example, if you change the horizontal timebase or the vertical gain, the mask is redrawn with the new settings.</p> <p>When you turn off <b>Source Lock</b>, the mask is not redrawn when horizontal or vertical settings are changed.</p>
<b>Source</b>	<p>If you change the Source channel, the mask is not erased. It is re-scaled to the vertical gain and offset settings of the channel to which it is assigned. To create a new mask for the selected source channel, select <b>Automask...</b>, and in the Automask dialog box, select <b>Create Mask</b>.</p> <p>The <b>Source</b> drop-down list in the Mask Test dialog box is the same as the <b>Source</b> drop-down list in the Automask dialog box.</p>
<b>Test All</b>	<p>When enabled, and waveforms are overlaid, all displayed analog channels are included in the mask test. When disabled, just the selected source channel is included in the test.</p>

## Mask Statistics

Statistics are shown in the Mask Test results window.



The following information is displayed:

- Current mask, name of mask, Channel number, date and time.
- Status (Passing, Failing, or Untested).
- Accumulated test time (in hours, minutes, seconds, and tenths of seconds).

- # of Tests (total number of mask tests executed).

And for each analog channel:

- The Source channel.
- Number of failures (acquisitions in which the signal excursion went beyond the mask).
- Failure rate (percentage of failures).
- Sigma (the ratio of process sigma to maximum achievable sigma, based on number of waveforms tested).

You can select **Reset Statistics** in the Mask Test dialog box. Note that statistics are also reset when:

- Mask Test is switched on after being switched off.
- **Clear Mask** is selected.
- **Create Mask** is selected in the Automask dialog box.

Additionally, the accumulated time counter continues whenever the oscilloscope is run after the acquisition was stopped.

## To manually modify a mask file

You can manually modify a mask file that you created using the Automask function.

- 1 Follow the steps 1-7 in "**To create a mask from a "golden" waveform (Automask)**" on page 221. Do not clear the mask after creating it.
- 2 Attach a USB mass storage device to the oscilloscope.
- 3 From the main menu, choose **File > Save...**
- 4 In the Save dialog box, from the **Format** drop-down list, select **Mask (\*.msk)**.
- 5 Enter a **File Name**, and select a destination folder on your USB mass storage device.
- 6 Select **Save**.  
This creates an ASCII text file that describes the mask.
- 7 Remove the USB mass storage device and connect it to a PC.
- 8 Open the .msk file you created using a text editor (such as Notepad).
- 9 Edit, save, and close the file.

The mask file contains the following sections:

- Mask File Identifier.
- Mask Title.
- Mask Violation Regions.

- Oscilloscope Setup Information.

**Mask File Identifier** The Mask File Identifier is MASK\_FILE\_548XX.

**Mask Title** The Mask Title is a string of ASCII characters. Example: autoMask CH1 OCT 03 09:40:26 2008

When a mask file contains the keyword "autoMask" in the title, the edge of the mask is passing by definition. Otherwise, the edge of the mask is defined as a failure.

### Mask Violation Regions



Up to 8 regions can be defined for a mask. They can be numbered 1-8. They can appear in any order in the .msk file. The numbering of the regions must go from top to bottom, left to right.

An Automask file contains two special regions: the region "glued" to the top of the display, and the region that is "glued" to the bottom. The top region is indicated by y-values of "MAX" for the first and last points. The bottom region is indicated by y-values of "MIN" for the first and last points.

The top region must be the lowest numbered region in the file. The bottom region must be the highest numbered region in the file.

Region number 1 is the top mask region. The vertices in Region 1 describe points along a line; that line is the bottom edge of the top portion of the mask.

Similarly, the vertices in Region 2 describe the line that forms the top of the bottom part of the mask.

The vertices in a mask file are normalized. There are four parameters that define how values are normalized:

- X1
- $\Delta X$
- Y1
- Y2

These four parameters are defined in the Oscilloscope Setup portion of the mask file.

The Y-values (normally voltage) are normalized in the file using the following equation:

$$Y_{\text{norm}} = (Y - Y1)/\Delta Y$$

where  $\Delta Y = Y2 - Y1$

To convert the normalized Y-values in the mask file to voltage:

$$Y = (Y_{\text{norm}} * \Delta Y) + Y1$$

where  $\Delta Y = Y2 - Y1$

The X-values (normally time) are normalized in the file using the following equation:

$$X_{\text{norm}} = (X - X1)/\Delta X$$

To convert the normalized X-values to time:

$$X = (X_{\text{norm}} * \Delta X) + X1$$

### Oscilloscope Setup Information

The keywords "setup" and "end\_setup" (appearing alone on a line) define the beginning and end of the oscilloscope setup region of the mask file. The oscilloscope setup information contains remote programming language commands that the oscilloscope executes when the mask file is loaded.

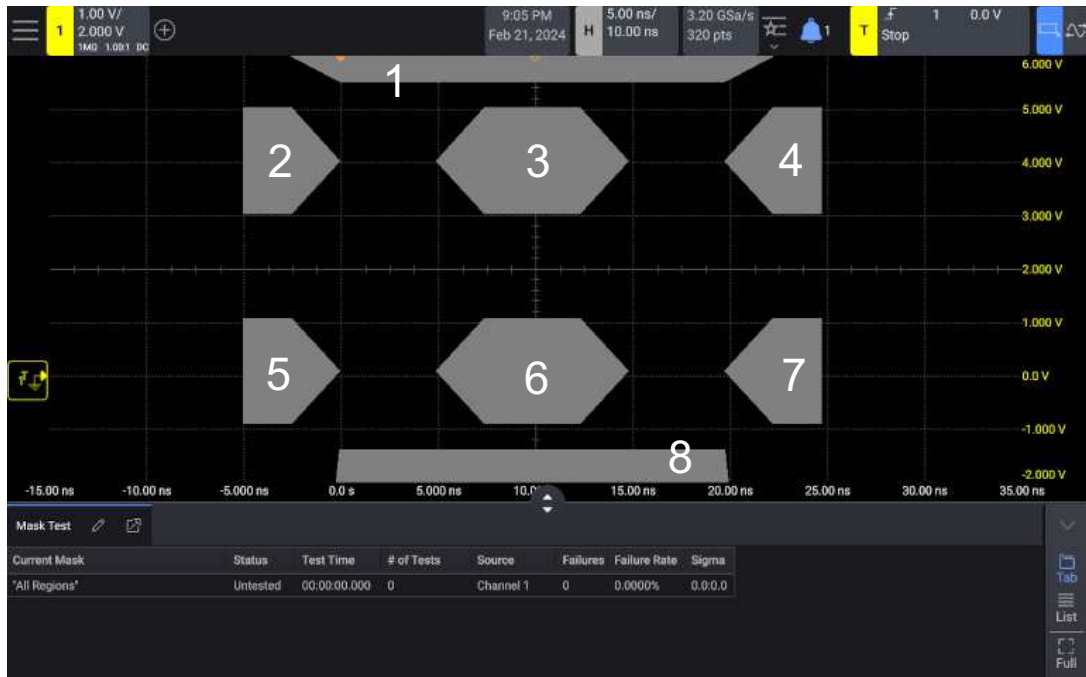
Any legal remote programming command can be entered in this section.

The mask scaling controls how the normalized vectors are interpreted. This in turn controls how the mask is drawn on the display. The remote programming commands that control mask scaling are:

```
:MTES:SCAL:BIND 0
:MTES:SCAL:X1 -400.000E-06
:MTES:SCAL:XDEL +800.000E-06
:MTES:SCAL:Y1 +359.000E-03
:MTES:SCAL:Y2 +2.35900E+00
```

## Building a Mask File

The following display shows a mask that uses all eight regions.



This mask is created by recalling the following mask file:

```

MASK_FILE_548XX

"All Regions"

/* Region Number */ 1
/* Number of vertices */ 4
-12.50, MAX
-10.00, 1.750
10.00, 1.750
12.50, MAX

/* Region Number */ 2
/* Number of vertices */ 5
-10.00, 1.000
-12.50, 0.500
-15.00, 0.500
-15.00, 1.500
-12.50, 1.500

/* Region Number */ 3
/* Number of vertices */ 6
-05.00, 1.000
-02.50, 0.500

```

```

02.50, 0.500
05.00, 1.000
02.50, 1.500
-02.50, 1.500

/* Region Number */ 4
/* Number of vertices */ 5
10.00, 1.000
12.50, 0.500
15.00, 0.500
15.00, 1.500
12.50, 1.500

/* Region Number */ 5
/* Number of vertices */ 5
-10.00, -1.000
-12.50, -0.500
-15.00, -0.500
-15.00, -1.500
-12.50, -1.500

/* Region Number */ 6
/* Number of vertices */ 6
-05.00, -1.000
-02.50, -0.500
02.50, -0.500
05.00, -1.000
02.50, -1.500
-02.50, -1.500

/* Region Number */ 7
/* Number of vertices */ 5
10.00, -1.000
12.50, -0.500
15.00, -0.500
15.00, -1.500
12.50, -1.500

/* Region Number */ 8
/* Number of vertices */ 4
-12.50, MIN
-10.00, -1.750
10.00, -1.750
12.50, MIN

setup
:CHANnel1:RANGe +8.00E+00
:CHANnel1:OFFSet +2.0E+00
:CHANnel1:DISPlay 1
:TIMEbase:MODE MAIN
:TIMEbase:REFerence CENTER
:TIMEbase:RANGe +50.00E-09
:TIMEbase:POSition +10.0E-09
:MTESt:SOURce CHANnel1
:MTESt:ENABle 1
:MTESt:LOCK 1
:MTESt:SCALe:X1 +10.0E-09

```

```
:MTESt:SCALe:XDELta +1.0000E-09
:MTESt:SCALe:Y1 +2.0E+00
:MTESt:SCALe:Y2 +4.00000E+00
end_setup
```

In a mask file, all region definitions need to be separated by a blank line.

Mask regions are defined by a number of (x,y) coordinate vertices (as on an ordinary x,y graph). A "y" value of "MAX" specifies the top of the graticule, and a "y" value of "MIN" specifies the bottom of the graticule.

#### NOTE

**If there are more than 1000 vertices in a mask region, only the first 1000 vertices will be processed.**

The mask x,y graph is related to the oscilloscope graticule using the :MTESt:SCALe setup commands.

The oscilloscope's graticule has a time reference location (at the left, center, or right of the screen) and a trigger (t=0) position/delay value relative to the reference. The graticule also has a vertical ground 0 V reference (offset relative to the center of the screen) location.

The X1 and Y1 setup commands relate the mask region's x,y graph origin to the oscilloscope graticule's t=0 and V=0 reference locations, and the XDELta and Y2 setup commands specify the size of the graph's x and y units.

- The X1 setup command specifies the time location of the x,y graph's x origin.
- The Y1 setup command specifies the vertical location of the x,y graph's y origin.
- The XDELta setup command specifies the amount of time associated with each x unit.
- The Y2 setup command is the vertical location of the x,y graph's y=1 value (so in effect, Y2 – Y1 is the YDELta value).

For example:

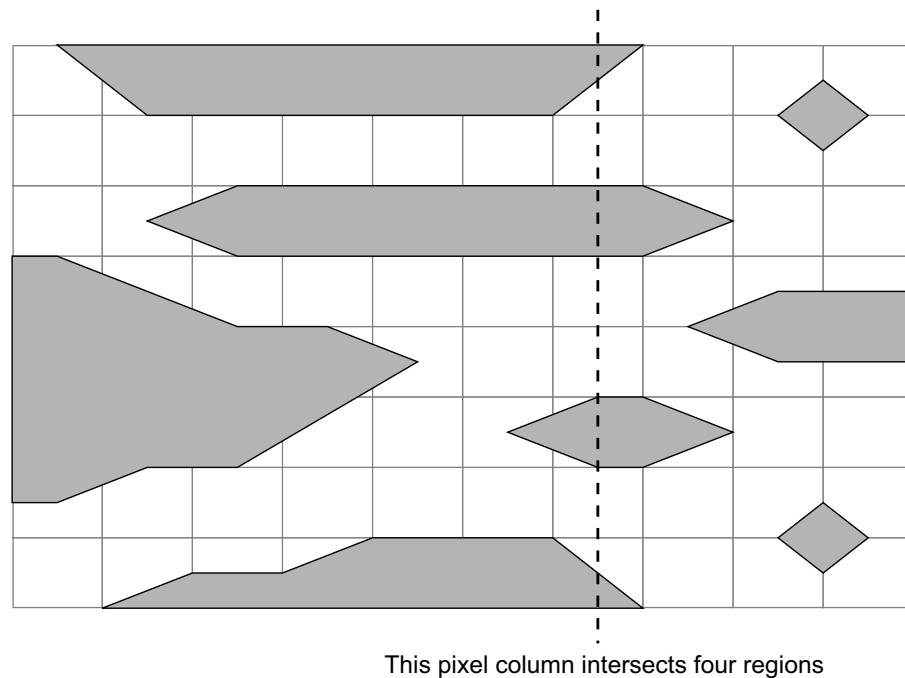
- With a graticule whose trigger position is 10 ns (before a center screen reference) and whose ground reference (offset) is 2 V below the center of the screen, to place the mask region's x,y graph's origin at center screen, you would set X1 = 10 ns and Y1 = 2 V.
- If the XDELta parameter is set to 5 ns and Y2 is set to 4 V, a mask region whose vertices are (-1, 1), (1, 1), (1, -1), and (-1, -1) goes from 5 ns to 15 ns and from 0 V to 4 V.
- If you move the mask region's x,y graph origin to the t=0 and V=0 location by setting X1 = 0 and Y1 = 0, the same vertices define a region that goes from -5 ns to 5 ns and from -2 V to 2 V.

## Mask Region Limit Per Pixel Column

In a mask:

- A maximum of eight regions can be defined.
- However, any given pixel column can intersect a maximum of four different regions.
- If there are four regions in a pixel column, one of the regions must include the top pixel (the MAX y value) and another region must include the bottom pixel (the MIN y value).

Here is an example of a valid eight-region mask:



Note that there is no pixel column that intersects more than four of the regions. Any column that has four regions includes the regions that are tied to the top and bottom, respectively.

## How is mask testing done?

InfiniiVision oscilloscopes start mask testing by creating a database that is 200 x 640 for the waveform viewing area. Each location in the array is designated as either a violation or a pass area. Each time a data point from a waveform occurs in a violation area a failure is logged. If **Test All** was selected, every active analog channel is tested against the mask database for each acquisition. Over 2 billion failures can be logged per-channel. The number of acquisitions tested is also logged and displayed as "# of Tests".

The mask file allows greater resolution than the 200 X 640 database. Some quantization of data occurs to reduce the mask file data for display on-screen.



# 17 Digital Voltmeter and Counters

Digital Voltmeter / 235  
Counters / 237

The Digital Voltmeter (DVM) and Counter analysis features are standard on the HD3-Series oscilloscopes.



## Digital Voltmeter

The digital voltmeter (DVM) analysis feature provides 3-digit voltage measurements on any analog channel. DVM measurements are asynchronous from the oscilloscope's acquisition system and are always acquiring.

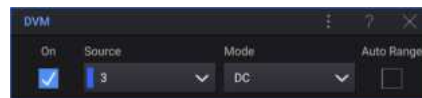
The DVM display is a seven-segment readout like you would see on a digital voltmeter. It shows the selected mode as well as the units. Units are specified in the channel's Probe dialog box.

The DVM display also has a scale that is determined by the channel's vertical scale and reference level. The scale's blue triangle pointer shows the most recent measurement. The bar above that shows the measurement extrema over the last 3 seconds.

The DVM makes accurate RMS measurements when the signal frequency is between 20 Hz and 100 kHz. When the signal frequency is outside this range, "<BW Limit?" or ">BW Limit?" appears in the DVM display to caution you about inaccurate RMS measurement results.

To use the digital voltmeter:

- 1 From the main menu, choose **Measure > Digital Voltmeter (DVM)...**
- 2 In the DVM dialog box, select **On** to enable or disable the digital voltmeter.



- 3 From the **Source** drop-down list, select the analog channel on which digital voltmeter (DVM) measurements are made.

The selected channel does not have to be on (displaying a waveform) in order for DVM measurements to be made.

- 4 From the **Mode** drop-down list, select:
  - **AC RMS** – Displays the root-mean-square value of the acquired data, with the DC component removed.
  - **DC** – Displays the DC value of the acquired data.
  - **DC RMS** – Displays the root-mean-square value of the acquired data.
- 5 If the selected source channel is not used in oscilloscope triggering, select **Auto Range** to disable or enable automatic adjustment of the DVM channel's vertical scale, vertical (ground level) position, and trigger (threshold voltage) level (used for the counter frequency measurement).

When enabled, **Auto Range** overrides attempted adjustments of the channel's vertical scale and position knobs.

When disabled, you can use the channel's vertical scale and position knobs normally.

## Counters

The counter analysis feature provides frequency, period, or edge event (totalize) counter measurements on any analog channel.

The counter counts trigger level crossings within a certain amount of time (gate time) and displays the results on a seven-segment readout (like you would see on a standalone counter instrument).

For frequency and period counter measurements:

- The gate time is specified indirectly by the selected number of digits of resolution, from 3 to 8. For higher resolutions, the gate time is greater.
- Up to 1 GHz (1.2 GHz typical) frequencies can be measured.

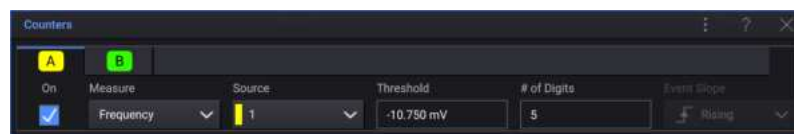
For totalize measurements:

- A running count of edges is kept. You can choose whether to count positive or negative edges.
- Edge events with up to 1 GHz (1.2 GHz typical) frequencies can be counted.

The counter is asynchronous from the oscilloscope's acquisition system and is always acquiring.

To use a counter:

- 1 From the main menu, choose **Measure > Counters...**
- 2 The Counters dialog box has tabs for the two available counters, A and B. Select the tab for the counter you want to use.
- 3 Select **On** to enable or disable the counter.



- 4 From the **Measure** drop-down list, select what the counter measures:
  - **Frequency** – Measures the cycles per second (Hz, kHz, or MHz) of the signal.
  - **Period** – Measures the time periods of the signal's cycles.
  - **Totalize** – Measures the count of edge events on the signal.

When **Totalize** is selected, the **Event Slope** drop-down list, selects whether **Rising** or **Falling** edge events are counted.

For frequency and period measurements, select the **# of Digits** field, and enter the resolution of the counter. You can choose from 3 to 8 digit resolutions.

Higher resolutions require longer gate times, which cause the measurement times to be longer as well.

- 5 From the **Source** drop-down list, select the analog channel or **Trigger Qualified Event** signal to make counter measurements on.

With the **Trigger Qualified Event** source (available when the trigger mode is not Edge), you can see how often trigger events are detected. This can be more often than when triggers actually occur, due to the oscilloscope's acquisition time or update rate capabilities. The AUX OUT signal shows when triggers actually occur. Remember that the oscilloscope's trigger circuitry does not re-arm until the holdoff time occurs and that the minimum holdoff time is 40 ns; therefore, the maximum trigger qualified event frequency that can be counted is 25 MHz.

The selected channel does not have to be on (displaying a waveform) in order for counter measurements to be made.

- 6 Select the **Threshold** field, and enter the threshold voltage (trigger) level for the selected analog channel source.

# 18 Fault Hunter

Statisticians say values more than three standard deviations away from the mean are *outliers*. With digital signals, outliers can indicate errors, faults, or anomalies. Oscilloscope measurements already include mean and standard deviation statistics. Given a statistically significant number of samples (acquisitions), limits can be determined from the mean and standard deviation values. With the determined limits, tests to find anomalies can be automatically set up. These tests use the available triggers.

This is what Fault Hunter does:

- 1 Adds some key measurements.
- 2 Runs the oscilloscope long enough to get thousands of measurements.
- 3 Uses the mean and standard deviation statistics to set up tests (using trigger modes).
- 4 Let you run the tests to find anomalies.

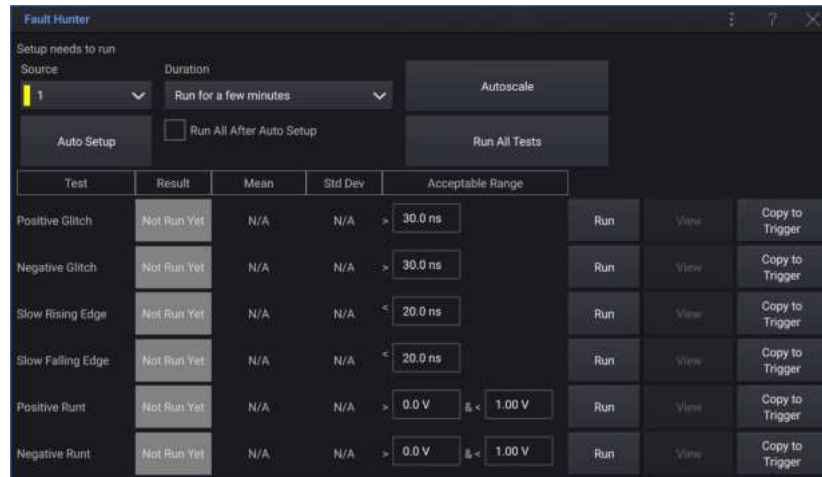
Fault Hunter saves you time by automatically determining limits and by automatically setting up tests.

To set up and run Fault Hunter:

- 1 First, make sure the digital signal is being captured appropriately:
  - Make sure there is a stable edge trigger for the waveform.
  - Make sure that more than four pulses of the waveform are being captured.

If these conditions are not true, you will get errors during the Fault Hunter automatic set up.

- 2 From the main menu, choose **Analyze > Fault Hunter...**
- 3 In the Fault Hunter dialog box, for the purposes of this description, de-select the **Run All After Auto Setup** check box.



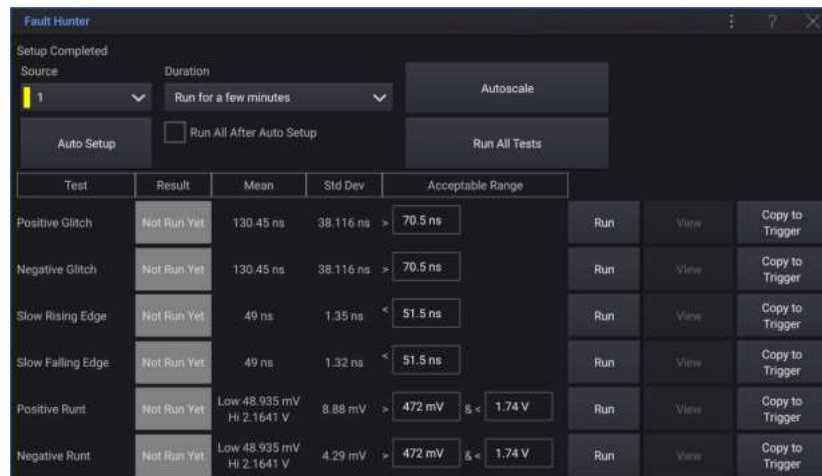
4 Select **Auto Setup**.

**NOTE**

**Auto Setup** is the most important step in using Fault Hunter.

This will add a set of measurements on the signal that are used to determine the measurement limits. For more about this process, see "[More About Fault Hunter Auto Setup](#)" on page 242.

When Fault Hunter is done setting up the measurement limits, you will see limit values populated in the test table.



If the signal under test changes, select **Auto Setup** again to re-calculate the measurement limits.

Note that you can manually adjust the determined limits.

- 5 Select the **Duration**, that is, whether you want to run the tests for a few minutes, an hour, eight hours, or two days.
- 6 Select **Run All Tests**.

When the run is completed, you will see "Passed" or "Failed" test results.

Test	Result	Mean	Std Dev	Acceptable Range	Run	View	Copy to Trigger
Positive Glitch	Failed	130.45 ns	38.116 ns	> 70.5 ns	Run	View	Copy to Trigger
Negative Glitch	Passed	130.45 ns	38.116 ns	> 70.5 ns	Run	View	Copy to Trigger
Slow Rising Edge	Failed	49 ns	1.35 ns	< 51.5 ns	Run	View	Copy to Trigger
Slow Falling Edge	Passed	49 ns	1.32 ns	< 51.5 ns	Run	View	Copy to Trigger
Positive Runt	Failed	Low 48.935 mV Hi 2.1641 V	8.88 mV	> 472 mV & < 1.74 V	Run	View	Copy to Trigger
Negative Runt	Passed	Low 48.935 mV Hi 2.1641 V	4.29 mV	> 472 mV & < 1.74 V	Run	View	Copy to Trigger

The **Result** column shows "Failed" when that type of anomaly was found or "Passed" when that type of anomaly was not found.

The **Result** column shows "Not Run Yet" if the test cannot be run for some reason. For example, if the range of the pulse is less than what can be detected by the triggering hardware, "Not Run Yet" will appear.

- 7 To view an anomaly, select the associated **View** button.

The Fault Hunter View dialog box shows a screen capture of the anomaly.



- 8 To copy the trigger that found an anomaly, select the associated **Copy to Trigger** button.

After the trigger is copied, you can select the **T** (trigger) badge to view the Trigger dialog box, and you can select **Run** to acquire waveforms using this trigger.



- 9 You can always adjust the limits for an individual test in the Fault Hunter dialog box and select the test's **Run** button to re-run the test.

#### Errors that cannot be detected

Fault Hunter cannot detect these types of errors:

- Errors that are so common they happen almost as often as good waveforms.
- Errors that do not match up well with existing trigger modes, such as non-monotonic edges.
- Errors that are so rare they do not occur during the duration of the test runs.

## More About Fault Hunter Auto Setup

The Fault Hunter Auto Setup process consists of these stages:

- Adding Measurements
- Getting Top and Base Measurements
- Getting Measurement Values

#### Adding Measurements

For the digital signal source that Fault Hunter is operating on, these measurements are added:

- + width
- - width
- Rise time
- Fall time
- Pulse amplitude
- Pulse base
- Pulse top
- Data rate

**Getting Top and Base Measurements**

First, acquisitions are collected long enough to get a significant number of top and base measurements. The top and base measurements are used to set measurement thresholds for the other measurements.

**Getting Measurement Values**

Once measurement thresholds are determined, additional acquisitions are made to get a significant number of values for the other added measurements. The means and standard deviations of these measurements are used to determine the acceptable ranges for the Fault Hunter tests:

Fault Hunter Test	Acceptable Range Determination
Positive Glitch	Positive pulses whose width is less than half the data rate's period are identified as positive glitches.
Negative Glitch	Negative pulses whose width is less than half the data rate's period are identified as negative glitches.
Slow Rising Edge	Rising edges that are 3 standard deviations longer than the mean are identified as slow edges.
Slow Falling Edge	Falling edges that are 3 standard deviations longer than the mean are identified as slow edges.
Positive Runt (Triggering method only)	The high runt threshold is set at the top value minus 20% of the pulse amplitude. Positive pulses lower than the high threshold are identified as positive runts.
Negative Runt (Triggering method only)	The low runt threshold is set at the base value plus 20% of the pulse amplitude. Negative pulses higher than the low threshold are identified as negative runts.



# 19 Frequency Response Analysis

To make connections / 245

To set up and run the analysis / 246

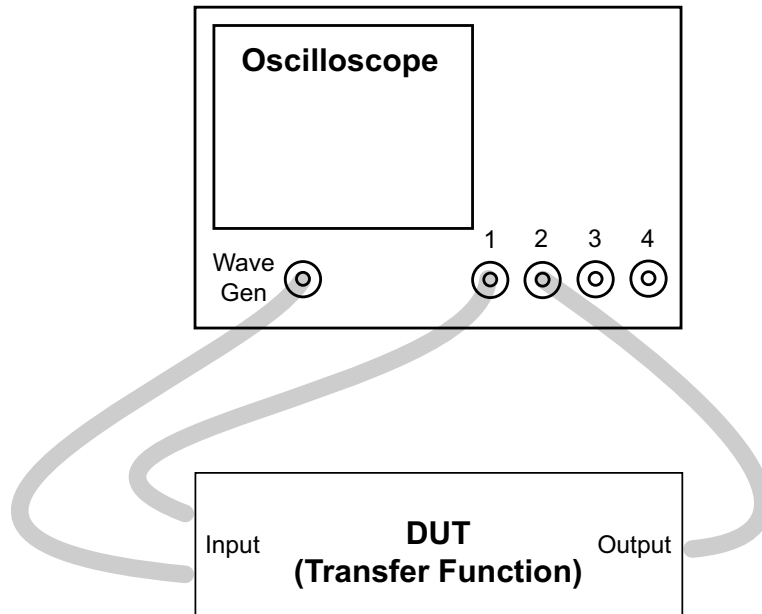
To view and save the analysis results / 247

The Frequency Response Analysis (FRA) feature controls the built-in waveform generator to sweep a sine wave across a range of frequencies while measuring the input to and output from a device under test (DUT). At each frequency, gain (A) and phase are measured and plotted on a frequency response Bode chart.

When the frequency response analysis completes, you can move a marker across the chart to see the measured gain and phase values at each frequency point. You can also adjust the chart's scale and offset settings for the gain and phase plots.

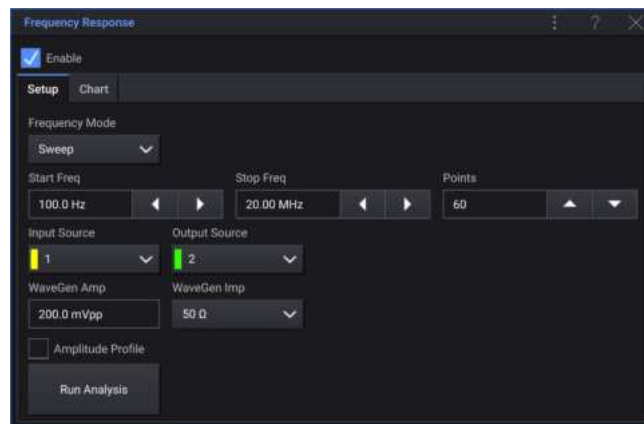
## To make connections

The waveform generator output is connected to a device under test (DUT). The input to the device and the output from the device are probed by the oscilloscope's input channels.



To set up and run the analysis

- 1 From the main menu, choose **Analyze > Frequency Response...**
- 2 In the Frequency Response dialog box, select **Enable**.
- 3 Click the **Open Dialog...** softkey to open the Frequency Response Analysis dialog box.
- 4 In the Frequency Response dialog box's Setup tab:



There are settings for:

- The **Frequency Mode**. Normally, you **Sweep** through a range of frequencies, making measurements. However, when debugging, you can select **Single** to make measurements at a single frequency.
- The start and stop frequencies in the sweep, as well as the number of points per decade.
- The channels probing the input and output.
- The waveform generator amplitude and expected output load impedance.

To specify different amplitudes for different decades, select **Amplitude Profile**.

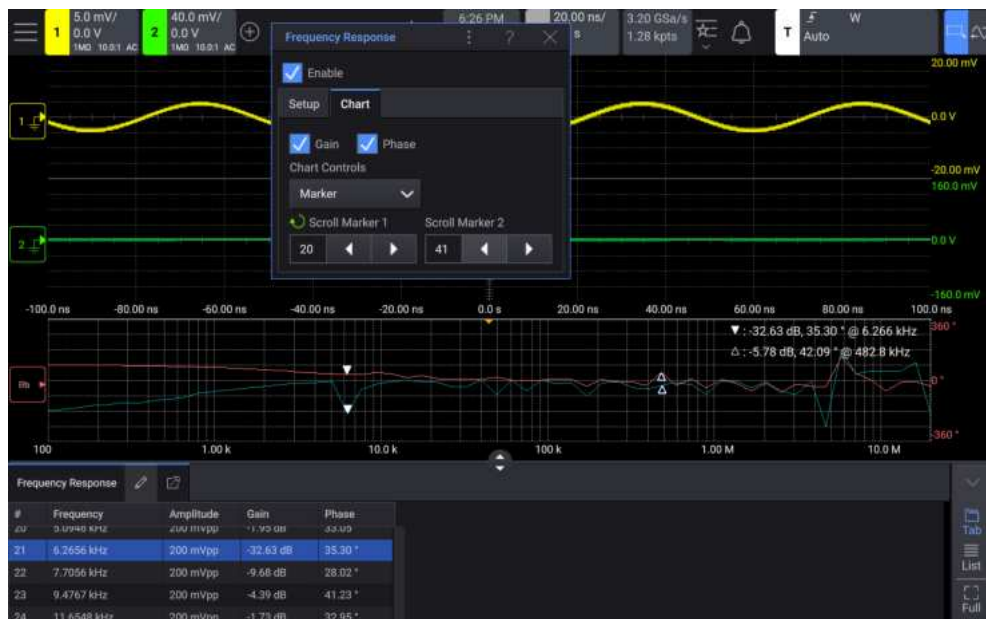
The output impedance of the Gen Out signal is fixed at 50 ohms. However, the output load selection lets the waveform generator display the correct amplitude and offset levels for the expected output load. If the actual load impedance is different than the selected value, the displayed amplitude and offset levels will be incorrect.

**5** To run the frequency response analysis, click the **Run Analysis**.

Gain and Phase measurements are plotted and added to a results table as the frequency sweeps from the start frequency to the stop frequency.

## To view and save the analysis results

When the frequency response analysis completes, Gain and Phase measurement results versus frequency are plotted in a Bode plot, log-scaled frequency grid and listed in a Results area table.



In the Frequency Response dialog box's Chart tab, there are controls for:

- Enabling or disabling the gain or phase plot and table results.
- Adjusting the scroll markers in the plot to see the values measured at particular locations.
- Viewing additional **Chart Controls**. The drop-down list lets you select:
  - **Gain** – for controls to adjust the gain plot's vertical scale and offset.
  - **Phase** – for controls to adjust the phase plot's vertical scale and offset.
  - **Frequency** – for controls to adjust the chart's horizontal frequency scale (starting and ending frequencies). The **Adj Mode** drop-down selections let you make normal, fine, or decade (coarse) adjustments to the chart's starting and ending frequencies.

The Results area table shows: the data point number, the frequency, the waveform generator output amplitude, the measured gain, and the measured phase. You can scroll the data.

To save the frequency response analysis results:

- 1 From the main menu, choose **File > Save...**
- 2 In the Save dialog box, from the **Format** drop-down menu, select **Frequency Response Analysis data (\*.csv)**.
- 3 Select the **File Name** field, and enter the name of the file you want to save.
- 4 Use the controls in the bottom of the dialog box to navigate to the location of the file to be saved.
- 5 Select **Save**.

To email the frequency response analysis results, see "**Emailing Setups, Screen Images, or Data**" on page 267. At the point where you choose the **Format** of information to be emailed, select **Frequency Response Analysis data (\*.csv)**.

## 20 Waveform Generator

- To select generated waveform types and settings / 249
- To specify the output settings / 253
- To edit arbitrary waveforms / 254
- To add modulation to the waveform generator output / 257

A waveform generator is built into the oscilloscope. It is enabled by the HD3WAVEGEN upgrade license. The waveform generator gives you an easy way to provide input signals when testing circuitry with the oscilloscope.

Waveform generator settings can be saved and recalled with oscilloscope setups. See **Chapter 21**, “Save/Email/Recall (Setups, Screens, Data),” starting on page 261.

### To select generated waveform types and settings

- 1 To access the Waveform Generator Menu and enable or disable the waveform generator output on the back panel Gen Out BNC, press the **[Wave Gen]** key.

Or, you can:

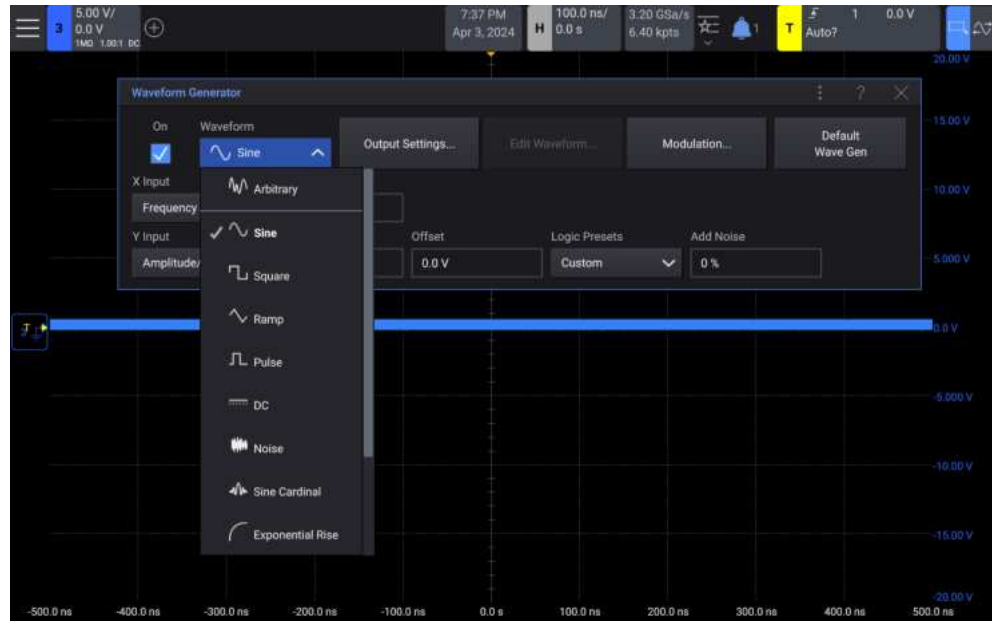
- a From the menu, choose **Sources > Waveform Generator...**
- b In the Waveform Generator dialog box, select **On**.

When waveform generator output is enabled, the **[Wave Gen]** key is illuminated. When waveform generator output is disabled, the **[Wave Gen]** key is off.

The waveform generator output is always disabled when the instrument is first turned on.

The waveform generator output is automatically disabled if excessive voltage is applied to the Gen Out BNC.

- 2 In the Waveform Generator dialog box, from the **Waveform** drop-down list, select the waveform type.



Waveform Type	Characteristics	Frequency Range	Max. Amplitude (High-Z) <sup>1</sup>	Offset Range (High-Z) <sup>1</sup>
<b>Arbitrary</b>	Use the <b>Frequency/Period</b> , <b>Amplitude/High-Level</b> , and <b>Offset/Low-Level</b> fields to set the arbitrary waveform signal parameters.  Select <b>Edit Waveform...</b> to define the arbitrary waveform shape. See " <b>To edit arbitrary waveforms</b> " on page 254.	300 MHz to 5 MHz	2 mVpp to 10 Vpp	When amplitude <50 mV: $\pm(800 \text{ mV} - 0.5 * \text{amplitude})$ When amplitude $\geq 50 \text{ mV}$ : $\pm(8 \text{ V} - 0.5 * \text{amplitude})$
<b>Sine</b>	Use the <b>Frequency/Period</b> , <b>Amplitude/High-Level</b> , and <b>Offset/Low-Level</b> fields to set the sine signal parameters.	10 MHz to 100 MHz	2 mVpp to 10 Vpp	When amplitude <50 mV: $\pm(800 \text{ mV} - 0.5 * \text{amplitude})$ When amplitude $\geq 50 \text{ mV}$ : $\pm(8 \text{ V} - 0.5 * \text{amplitude})$
<b>Square</b>	Use the <b>Frequency/Period</b> , <b>Amplitude/High-Level</b> , <b>Offset/Low-Level</b> , and <b>Duty Cycle</b> fields to set the square wave signal parameters.  The duty cycle can be adjusted from 20% to 80%.	10 MHz to 50 MHz	2 mVpp to 10 Vpp	When amplitude <50 mV: $\pm(800 \text{ mV} - 0.5 * \text{amplitude})$ When amplitude $\geq 50 \text{ mV}$ : $\pm(8 \text{ V} - 0.5 * \text{amplitude})$

Waveform Type	Characteristics	Frequency Range	Max. Amplitude (High-Z) <sup>1</sup>	Offset Range (High-Z) <sup>1</sup>
<b>Ramp</b>	Use the <b>Frequency/Period</b> , <b>Amplitude/High-Level</b> , <b>Offset/Low-Level</b> , and <b>Symmetry</b> fields to set the ramp signal parameters.  Symmetry represents the amount of time per cycle that the ramp waveform is rising and can be adjusted from 0% to 100%.	300 mHz to 5 MHz	2 mVpp to 10 Vpp	When amplitude <50 mV: $\pm(800 \text{ mV} - 0.5 * \text{amplitude})$ When amplitude $\geq 50$ mV: $\pm(8 \text{ V} - 0.5 * \text{amplitude})$
<b>Pulse</b>	Use the <b>Frequency/Period</b> , <b>Amplitude/High-Level</b> , <b>Offset/Low-Level</b> , and <b>Width/Width Fine</b> fields to set the pulse signal parameters.  For frequencies of 101.6 Hz and lower, the minimum pulse width is 300 ns. For frequencies of 6 kHz and higher, the minimum pulse width is 5 ns. For frequencies between 101.6 Hz and 6 kHz, the minimum pulse width goes linearly from 300 ns to 5 ns. The pulse width can be adjusted from the minimum to the period minus the minimum.	10 mHz to 50 MHz.	2 mVpp to 10 Vpp	When amplitude <50 mV: $\pm(800 \text{ mV} - 0.5 * \text{amplitude})$ When amplitude $\geq 50$ mV: $\pm(8 \text{ V} - 0.5 * \text{amplitude})$
<b>DC</b>	Use the <b>Offset</b> field to set the DC level.  Use the <b>DC Mode</b> drop-down list to select <b>Precise</b> levels (with a $\pm 1.00$ V range) or <b>Wide range</b> (of $\pm 8.00$ V).	n/a	n/a	$\pm 8.00$ V or $\pm 1.00$ V, depending on the <b>DC Mode</b> selection
<b>Noise</b>	Use the <b>Amplitude/High-Level</b> and <b>Offset/Low-Level</b> to set the noise signal parameters.	n/a	2 mVpp to 10 Vpp	When amplitude <50 mV: $\pm(800 \text{ mV} - 0.5 * \text{amplitude})$ When amplitude $\geq 50$ mV: $\pm(8 \text{ V} - 0.5 * \text{amplitude})$
<b>Sine Cardinal</b>	Use the <b>Frequency/Period</b> , <b>Amplitude</b> , and <b>Offset</b> fields to set the sinc signal parameters.	300 mHz to 5 MHz	2 mVpp to 10 Vpp	When amplitude <50 mV: $\pm(400 \text{ mV} - 0.25 * \text{amplitude})$ When amplitude $\geq 50$ mV: $\pm(4 \text{ V} - 0.25 * \text{amplitude})$
<b>Exponential Rise</b>	Use the <b>Frequency/Period</b> , <b>Amplitude/High-Level</b> , and <b>Offset/Low-Level</b> fields to set the exponential rise signal parameters.	300 mHz to 5 MHz	2 mVpp to 10 Vpp	When amplitude <50 mV: $\pm(800 \text{ mV} - 0.5 * \text{amplitude})$ When amplitude $\geq 50$ mV: $\pm(8 \text{ V} - 0.5 * \text{amplitude})$
<b>Exponential Fall</b>	Use the <b>Frequency/Period</b> , <b>Amplitude/High-Level</b> , and <b>Offset/Low-Level</b> fields to set the exponential fall signal parameters.	300 mHz to 5 MHz	2 mVpp to 10 Vpp	When amplitude <50 mV: $\pm(800 \text{ mV} - 0.5 * \text{amplitude})$ When amplitude $\geq 50$ mV: $\pm(8 \text{ V} - 0.5 * \text{amplitude})$

Waveform Type	Characteristics	Frequency Range	Max. Amplitude (High-Z) <sup>1</sup>	Offset Range (High-Z) <sup>1</sup>
<b>Cardiac</b>	Use the <b>Frequency/Period</b> , <b>Amplitude</b> , and <b>Offset</b> fields to set the cardiac signal parameters.	300 mHz to 5 MHz	2 mVpp to 10 Vpp	When amplitude <50 mV: $\pm(400 \text{ mV} - 0.25 * \text{amplitude})$ When amplitude $\geq 50 \text{ mV}$ : $\pm(4 \text{ V} - 0.25 * \text{amplitude})$
<b>Gaussian Pulse</b>	Use the <b>Frequency/Period</b> , <b>Amplitude</b> , and <b>Offset</b> fields to set the Gaussian pulse signal parameters.	300 mHz to 5 MHz	2 mVpp to 8 Vpp	When amplitude <50 mV: $\pm(400 \text{ mV} - 0.25 * \text{amplitude})$ When amplitude $\geq 50 \text{ mV}$ : $\pm(4 \text{ V} - 0.25 * \text{amplitude})$

<sup>1</sup>When the output load is 50  $\Omega$ , these values are halved.

- 3** Depending on the selected waveform type, use the remaining controls in the Waveform Generator dialog box to set the waveform's characteristics.
- **X Input** – Select between entering the **Frequency** or **Period** of the output waveform. Use the **Frequency** or **Period** field to enter the value.
  - **Y Input** – Select between entering **Amplitude/Offset** or **High/Low** values to specify the output waveform's voltage swing. Use the **Amplitude** and **Offset** or **Low-Level** and **high-Level** fields to enter the values.
  - **Logic Presets** – Sets the output voltage to TTL, CMOS (5.0V), CMOS (3.3V), CMOS (2.5V), or ECL compatible Low and High levels.

Logic Preset	Low level	High level
<b>TTL</b>	0 V	+5 V (or a TTL-compatible high level if +5 V cannot be reached)
<b>CMOS (5.0V)</b>	0 V	+5 V
<b>CMOS (3.3V)</b>	0 V	+3.3 V
<b>CMOS (2.5V)</b>	0 V	+2.5 V
<b>ECL</b>	-1.7 V	-0.9 V

- **Add Noise** – Specifies the amount of white noise to add to the waveform generator output.

Note that adding noise affects edge triggering on the waveform generator source (see ["Edge Trigger"](#) on page 137) as well as the waveform generator sync pulse output signal (which can be sent to AUX OUT, see ["Setting the Rear Panel AUX OUT Source"](#) on page 282). This is because the trigger comparator is located after the noise source.

- **Output Settings...** – Opens the Output Settings dialog box where you can specify the expected output load, invert the output, and output the waveform generator sync pulse. See ["To specify the output settings"](#) on page 253.
- **Edit Waveform...** – Opens the ["To edit arbitrary waveforms"](#) on page 254 where you can edit arbitrary waveforms.
- **Modulation...** – Opens the Modulation dialog box where you can add modulation to the waveform generator output. See ["To add modulation to the waveform generator output"](#) on page 257.
- **Default Wave Gen** – Returns the waveform generator to its default settings.

The waveform generator factory default settings (1 kHz sine wave, 500 mVpp, 0 V offset, High-Z output load) are restored.

- See:
- ["To specify the output settings"](#) on page 253
  - ["To edit arbitrary waveforms"](#) on page 254
  - ["To add modulation to the waveform generator output"](#) on page 257

## To specify the output settings

In the Waveform Generator dialog box, click **Output Settings...** to open the Output Settings dialog box.

The Output Settings dialog box has these controls:



- **Output Load** – The expected output load can be **50 Ω** or **High-Z**.

The output impedance of the Gen Out BNC is fixed at 50 ohms. However, the output load selection lets the waveform generator display the correct amplitude and offset levels for the expected output load.

If the actual load impedance is different than the selected value, the displayed amplitude and offset levels will be incorrect.

- **Invert Output** – Lets you enable or disable an inverted output.

Note that when inverted output is enabled, the waveform's offset is not inverted.

- **Aux Out** – Specifies the signal that is output on the oscilloscope's rear panel AUX OUT BNC connector:
  - **Triggers** – Each time the oscilloscope triggers, a rising edge occurs on AUX OUT. The rising edge is delayed 1.06  $\mu$ s from the oscilloscope's trigger point. The output level is 0-5 V into an open circuit, and 0-2.5 V into 50  $\Omega$ .
  - **Mask** – The pass/fail status is evaluated periodically. When the evaluation of the testing period results in a failure, the trigger output pulses high (+5 V). Otherwise, the trigger output remains at low (0 V).
  - **Waveform Generator Sync Pulse** – All of the waveform generator output functions (except DC, Noise, and Cardiac) have an associated Sync signal:

Waveform Type	Sync Signal Characteristics
All waveforms except DC, Noise, and Cardiac	The Sync signal is a TTL positive pulse that occurs when the waveform rises above zero volts (or the DC offset value).
DC, Noise, and Cardiac	N/A

## To edit arbitrary waveforms

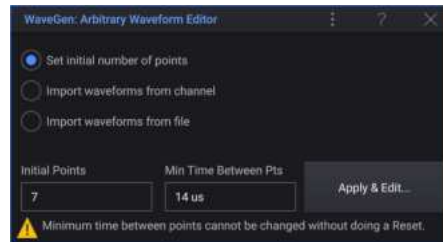
When **Arbitrary** is selected as the generated waveform type (see "**To select generated waveform types and settings**" on page 249), select **Edit Waveform...** to open the WaveGen: Arbitrary Waveform Editor dialog box.

This dialog box has two formats depending on whether there are currently defined arbitrary waveform points.

### When No Points Exist

The WaveGen: Arbitrary Waveform Editor dialog box lets you set up an arbitrary waveform in one of these ways:

- **Set initial number of points** – When selected, to create a new arbitrary waveform:



- a Enter the number of **Initial Points**.

The new waveform will be a square wave with the number of points you specify. The points are evenly spaced over the time period.

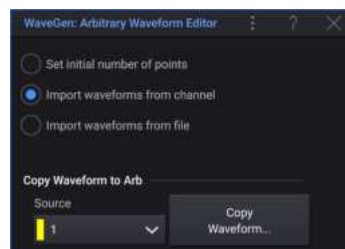
- b Enter the **Min Time Between Pts**, that is, the minimum time between points.

The resolution is specified during arbitrary waveform creation only. To change the resolution of an arbitrary waveform, you must clear all arbitrary waveform points (with a **Reset** when editing points), and create the waveform again.

- c When you are ready to create the new arbitrary waveform, select **Apply & Edit...**

The new waveform is created and the Arbitrary Waveform Editor dialog box is opened.

- **Import waveforms from channel** – When selected, to capture another waveform to the arbitrary waveform:



- a From the **Source** drop-down list, select the analog channel, math, or reference location whose waveform you wish to capture.

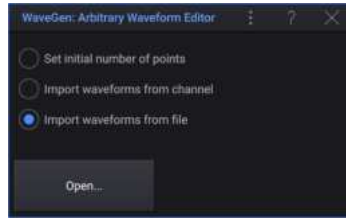
- b Select **Copy Waveform....**

The source waveform is decimated into 8192 (maximum) or fewer arbitrary waveform points.

## NOTE

If the source waveform frequency and/or voltage exceed the capabilities of the waveform generator, the arbitrary waveform will be limited to the capabilities of the waveform generator. For example, a 50 MHz waveform captured as the arbitrary waveform, becomes a 25 MHz waveform.

- **Import waveforms from file** – When selected,



- Select **Open...** to open a file browser dialog box.
- Select the file to import.
- Select **Open**.

**When Points Exist** The WaveGen: Arbitrary Waveform Editor dialog box has these controls:




- **Full arbitrary waveform grid** – Shows the full arbitrary waveform.
 

The voltage and time period you see in the grid are the bounding parameters – they come from the frequency and amplitude settings in the main Waveform Generator dialog box.

If the lower, windowed points grid's **X Scale** is less than the full scale, a shaded area appears, highlighting the points that are displayed in the lower grid. You can drag the shaded area to show different arbitrary waveform points in the lower grid; this changes the windowed points grid's **X Position**.
- **Windowed points grid** – Shows a window of points in the arbitrary waveform.
 

Arbitrary waveform points appear as solid boxes that can be selected. When a point is selected, it is highlighted and has horizontal and vertical markers with handles that can be dragged to set the point's time and voltage value.

You can draw a box in this grid (and let up) to select a region, cut points, copy points, paste points, or zoom in (change the **X Scale**).
- **X Scale** – Changes the time/div in the lower, windowed points grid.

- **X Position** – Sets the lower, windowed points grid's beginning (left side) time. The maximum **X Position** value is the full grid's width minus the width of the windowed points grid.
-  Insert, Cut, Copy, Paste, Undo – Arbitrary waveform points editing buttons.
- **Interpolate** – Specifies how lines are drawn between arbitrary waveform points. When enabled, lines are drawn between points in the waveform editor. Voltage levels change linearly between one point and the next. When disabled, all line segments in the waveform editor are horizontal. The voltage level of one point remains until the next point.
- **Reset** – Clears all the arbitrary waveform points.

**NOTE**

You can save arbitrary waveforms to internal storage locations or to a USB storage device, and you can recall them later. See ["To save arbitrary waveforms"](#) on page 267 and ["To recall arbitrary waveforms"](#) on page 271.

- **Selected Point X** – Lets you enter an exact time value for a point.
- **Selected Point Y** – Lets you enter an exact voltage value for a point.
- Arbitrary waveform points table – Shows the X and Y values of the arbitrary waveform points.

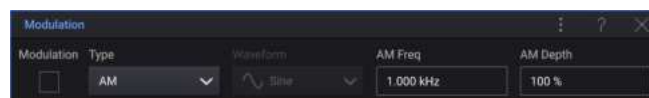
Selecting rows in this table is another way of selecting arbitrary waveform points.

## To add modulation to the waveform generator output

Modulation is where an original carrier signal is modified according to the amplitude of a second modulating signal. The modulation type (AM or FM) specifies how the carrier signal is modified.

To enable and set up modulation for the waveform generator output:

- 1 In the Waveform Generator dialog box, click **Modulation...** to open the Modulation dialog box.
- 2 In the Modulation dialog box:



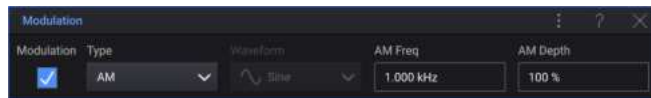
- Select **Modulation** to enable or disable modulated waveform generator output.

You can enable modulation for all waveform generator function types except arbitrary, square, pulse, DC, noise, and Gaussian pulse.

- From the **Type** drop-down list, select the modulation type:
  - **Amplitude Modulation (AM)** – the amplitude of the original carrier signal is modified according to the amplitude of the modulating signal. See "[To set up Amplitude Modulation \(AM\)](#)" on page 258.
  - **Frequency Modulation (FM)** – the frequency of the original carrier signal is modified according to the amplitude of the modulating signal. See "[To set up Frequency Modulation \(FM\)](#)" on page 259.

## To set up Amplitude Modulation (AM)

In the Modulation dialog box when **Amplitude Modulation (AM)** is selected:



- 1 From the **Waveform** drop-down list, select the shape of the modulating signal:
  - **Sine**
- 2 In the **AM Freq** field, enter the frequency of the modulating signal.
- 3 In the **AM Depth** field, enter the amount of amplitude modulation.

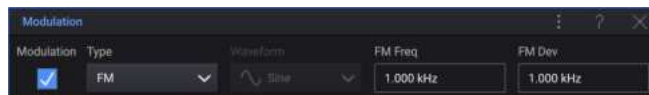
AM Depth refers to the portion of the amplitude range that will be used by the modulation. For example, a depth setting of 80% causes the output amplitude to vary from 10% to 90% ( $90\% - 10\% = 80\%$ ) of the original amplitude as the modulating signal goes from its minimum to maximum amplitude.

The following screen shows an AM modulation of a 100 kHz sine wave carrier signal.



To set up Frequency Modulation (FM)

In the Modulation dialog box when **Frequency Modulation (FM)** is selected:



- 1 From the **Waveform** drop-down list, select the shape of the modulating signal:
  - **Sine**
- 2 In the **FM Freq** field, enter the frequency of the modulating signal.
- 3 In the **FM Dev** field, enter the frequency deviation from the original carrier signal frequency.

When the modulating signal is at its maximum amplitude, the output frequency is the carrier signal frequency plus the deviation amount, and when the modulating signal is at its minimum amplitude, the output frequency is the carrier signal frequency minus the deviation amount.

The frequency deviation cannot be greater than the original carrier signal frequency.

Also, the sum of the original carrier signal frequency and the frequency deviation must be less than or equal to the maximum frequency for the selected waveform generator function plus 100 kHz.

The following screen shows an FM modulation of a 100 kHz sine wave carrier signal.



## 21 Save/Email/Recall (Setups, Screens, Data)

Saving Setups, Screen Images, or Data / 261

Emailing Setups, Screen Images, or Data / 267

Recalling Setups, Masks, or Data / 269

Recalling Default Setups / 271

Performing a Secure Erase / 272

Oscilloscope setups, reference waveforms, and mask files can be saved to internal oscilloscope memory or to a USB storage device and recalled later. You can also recall default or factory default setups.

Oscilloscope screen images can be saved to a USB storage device in BMP or PNG formats.

Acquired waveform data can be saved to a USB storage device in comma-separated value (CSV), ASCII XY, and binary (BIN) formats.

Any file that can be saved to a USB storage device can also be e-mailed over the network.

There is also a command to securely erase all the oscilloscope's non-volatile internal memory.

### Saving Setups, Screen Images, or Data

- 1 From the main menu, choose **File > Save...**
- 2 In the Save dialog box, from the **Format** drop-down menu, select the type of file you want to save:
  - **Setup (\*.scp)** – The oscilloscope's horizontal timebase, vertical sensitivity, trigger mode, trigger level, measurements, markers, and math function settings that tell the oscilloscope how to make a particular measurement. See "**To save setup files**" on page 263.

- **24-bit Bitmap image (\*.bmp)** – The complete screen image in a 24-bit color bitmap format. See ["To save BMP or PNG image files"](#) on page 263.
  - **PNG 24-bit image (\*.png)** – The complete screen image in a 24-bit color PNG format that uses lossless compression. Files are much smaller than the BMP format. See ["To save BMP or PNG image files"](#) on page 263.
  - **CSV data (\*.csv)** – This creates a file of comma-separated values of all displayed channels and math waveforms. This format is suitable for spreadsheet analysis. See ["To save CSV, ASCII XY, or BIN data files"](#) on page 264.
  - **ASCII XY data (\*.csv)** – This creates separate files of comma-separated values for each displayed channel. This format is also suitable for spreadsheets. See ["To save CSV, ASCII XY, or BIN data files"](#) on page 264.
  - **Binary data (\*.bin)** – This creates a binary file, with a header, and data in the form of time and voltage pairs. This file is much smaller than the ASCII XY data file. See ["To save CSV, ASCII XY, or BIN data files"](#) on page 264.
  - **Reference Waveform data (\*.h5)** – Saves waveform data in a format that can be recalled to one of the oscilloscope's reference waveform locations. See ["To save reference waveform files to a USB storage device"](#) on page 266.
  - **Multi Channel Waveform data (\*.h5)** – Saves multiple channels of waveform data in a format that can be opened by the N8900A Infiniium Offline oscilloscope analysis software. You can recall the first Analog or Math channel from a multi channel waveform data file.
  - **Mask (\*.msk)** – This creates a mask file in a Keysight proprietary format that can be read by Keysight InfiniiVision oscilloscopes. A mask data file includes some oscilloscope setup information, but not all setup information. To save all setup information including the mask data file, choose "Setup (\*.scp)" format instead. See ["To save masks"](#) on page 266.
  - **Arbitrary Waveform data (\*.csv)** – This creates a file of comma-separated values for the arbitrary waveform points' time and voltage values. See ["To save arbitrary waveforms"](#) on page 267.
  - **Analysis Results (\*.csv)** – A file of comma-separated values is saved for the analysis types selected using the **Save from:** drop-down menu.
  - **Frequency Response Analysis data (\*.csv)** – This creates a file of comma-separated values for the Frequency Response Analysis results table values. In the saved file, there are three data columns: frequency (Hz), gain (dB), and phase (degrees). See ["To view and save the analysis results"](#) on page 247.
- 3 Select any options for the type of file you want to save.
  - 4 Select the **File Name** field, and enter the name of the file you want to save.

The **Increment** option enables or disables automatically incremented file names. Auto increment adds a numeric suffix to your file name and increments the number with each successive save. It will truncate characters as necessary when the file name length is at maximum and more digits are required for the numeric portion of the file name.

- 5 Use the controls in the bottom of the dialog box to navigate to the location of the file to be saved.
- 6 Select **Save**.

A message indicating whether the save was successful is displayed.

You can also configure the **Setup > (Quick Action)** menu item to save setups, screen images, or data. See "[Configuring the \(Quick Action\) Menu Item](#)" on page 291.

## To save setup files

Setup files can be saved to internal hard drive (\User Files) locations or to an external USB storage device.

- 1 From the main menu, choose **File > Save...**
- 2 In the Save dialog box, from the **Format** drop-down menu, select **Setup (\*.scp)**.
- 3 Select the **File Name** field, and enter the name of the file you want to save.
- 4 Use the controls in the bottom of the dialog box to navigate to the location of the file to be saved.
- 5 Select **Save**.

## To save BMP or PNG image files

Image files can be saved to an external USB storage device.

- 1 From the main menu, choose **File > Save...**
- 2 In the Save dialog box, from the **Format** drop-down menu, select one of:
  - **24-bit Bitmap image (\*.bmp)**
  - **PNG 24-bit image (\*.png)**
- 3 With image files, you can select these options:
  - **Setup Info** – Setup information (vertical, horizontal, trigger, acquisition, math, and display settings) is also saved in a separate file with a TXT extension.
- 4 Select the **File Name** field, and enter the name of the file you want to save.
- 5 Use the controls in the bottom of the dialog box to navigate to the location of the file to be saved.
- 6 Select **Save**.

**NOTE**

When saving screen images, the oscilloscope uses the screen before the Save dialog box was opened.

To save a screen image showing the Save dialog box, press the **[Save Screen]** instead.

**NOTE**

You can also save the oscilloscope's display image using a web browser. See **"Get Image"** on page 297 for details.

See Also · **"To add an annotation"** on page 130

### To save CSV, ASCII XY, or BIN data files

Data files can be saved to an external USB storage device.

- 1 From the main menu, choose **File > Save...**
- 2 In the Save dialog box, from the **Format** drop-down menu, select one of:
  - **CSV data (\*.csv)** – See **"CSV Data"** on page 265.
  - **ASCII XY data (\*.csv)** – See **"ASCII XY Data"** on page 265.
  - **Binary data (\*.bin)**
- 3 With data files files, you can select these options:
  - **Setup Info** – Setup information (vertical, horizontal, trigger, acquisition, math, and display settings) is also saved in a separate file with a TXT extension.
  - **Max Length** – Specifies that the maximum number of waveform data points be saved. See **"Length Control"** on page 265.
  - **Length** – Sets the number of data points that will be output to the file. For more information, see **"Length Control"** on page 265.
  - **Save Segment** – When data is acquired to segmented memory, you can specify whether the **Current** displayed segment is saved or **All** acquired segments are saved. (See also **"Saving Data from Segmented Memory"** on page 174.)
- 4 Select the **File Name** field, and enter the name of the file you want to save.
- 5 Use the controls in the bottom of the dialog box to navigate to the location of the file to be saved.
- 6 Select **Save**.

See Also · **"Binary Data (.bin) Format"** on page 309  
 · **"CSV and ASCII XY files"** on page 315  
 · **"Minimum and Maximum Values in CSV Files"** on page 316

## CSV Data

When the CSV data (\*.csv) file format is selected, comma-separated values for each displayed waveform and digital channel pod are saved as multiple columns in a single file. Math FFT waveforms, whose values are in the frequency domain, are appended at the bottom of the .csv file. Pod names (for example, D0-D7) or waveform labels are used as column headers. This format is suitable for spreadsheet analysis.

For CSV data, length "N" value-at-time measurements are performed across the entire screen (using the analysis record data) for each active source. Interpolation between analysis record data points is performed as needed.

## ASCII XY Data

When the ASCII XY data (\*.csv) file format is selected, comma-separated value files for each displayed waveform, digital channel pod, digital bus, and serial bus are saved. For digital pods, an underscore ( \_ ) and the pod name (for example, D0-D7) are appended to the specified file name; otherwise, an underscore and the waveform's label are appended.

If the oscilloscope acquisition is stopped, data from the raw acquisition record (which has more points than the analysis record) can be written. Press the **[Single]** key to obtain maximum memory depth with current settings. If enabled, serial decode data is saved.

When you want to save less than the maximum number of data points, a 1-of-N decimation is performed to produce an output whose length is less than or equal to the requested length. For example, if there are 100k points of data, and you specify a length of 2k, 1 of every 50 data points is saved.

## Length Control

The **Length** control is available when saving data to CSV, ASCII XY, or BIN format files. It limits the maximum number of data points that can be saved.

When **Max Length** is enabled, the maximum number of waveform data points is saved.

The actual number of data points saved depends on displayed data and on these factors:

- Whether acquisitions are running. When stopped, data comes from the raw acquisition record. When running, data comes from a smaller running acquisition record.
- Whether the oscilloscope was stopped using **[Stop]** or **[Single]**. Running acquisitions use less memory to provide fast waveform update rates. Single acquisitions use full memory.
- The horizontal time/div (sweep speed) setting when stopped using **[Stop]**. At faster settings, fewer data points appear on the display.

- Whether segmented memory is on. Acquisition memory is divided by the number of segments.
- When saving to a CSV format file, the maximum number of data points is 1 Mpts.

When necessary, the Length control performs a "1 of n" decimation of the data . For example: if the **Length** is set to 1000, and you are displaying a record that is 5000 data points in length, four of each five data points will be decimated, creating an output file 1000 data points in length.

When saving waveform data, the save times depend on the chosen format:

Data File Format	Save Times
BIN	fastest
ASCII XY	medium
CSV	slowest

### To save reference waveform files to a USB storage device

- 1 From the main menu, choose **File > Save....**
- 2 In the Save dialog box, from the **Format** drop-down menu, select **Reference Waveform data (\*.h5)**.
- 3 From the **Source** drop-down list, select the source waveform.
- 4 Select the **File Name** field, and enter the name of the file you want to save.
- 5 Use the controls in the bottom of the dialog box to navigate to the location of the file to be saved.
- 6 Select **Save**.

### To save masks

Mask files can be saved to one of four internal (\User Files) locations or to an external USB storage device.

- 1 From the main menu, choose **File > Save....**
- 2 In the Save dialog box, from the **Format** drop-down menu, select **Mask (\*.msk)**.
- 3 Select the **File Name** field, and enter the name of the file you want to save.
- 4 Use the controls in the bottom of the dialog box to navigate to the location of the file to be saved.
- 5 Select **Save**.

Mask files have the extension MSK.

**NOTE**

Masks are also saved as part of setup files. See ["To save setup files"](#) on page 263.

**See Also** · [Chapter 16](#), "Mask Testing," starting on page 221

### To save arbitrary waveforms

Arbitrary waveform files can be saved to internal (\User Files) locations or to an external USB storage device.

- 1 From the main menu, choose **File > Save...**
- 2 In the Save dialog box, from the **Format** drop-down menu, select **Arbitrary Waveform data (\*.csv)**.
- 3 Select the **File Name** field, and enter the name of the file you want to save.
- 4 Use the controls in the bottom of the dialog box to navigate to the location of the file to be saved.
- 5 Select **Save**.

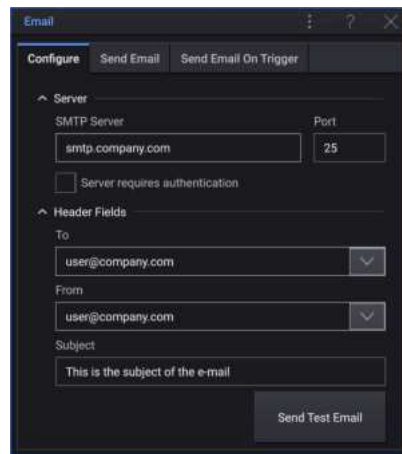
**See Also** · ["To edit arbitrary waveforms"](#) on page 254

## Emailing Setups, Screen Images, or Data

You can send oscilloscope files over the network via e-mail. You can e-mail any file that can be saved.

To e-mail a setup, screen image, or data file:

- 1 Make sure the oscilloscope is connected to the local area network (see ["To establish a LAN connection"](#) on page 275).
- 2 From the main menu, choose **File > Email...**
- 3 In the Email dialog box, select the **Configure** tab:



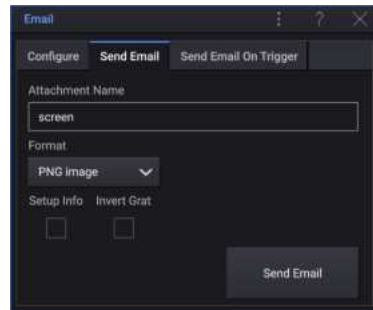
In the **Server** area:

- a Select the **SMTP Server** and **Port** fields and enter the name and port number of your SMTP server. If you do not know these values, ask your Network Administrator.
- b if your SMTP server requires authentication, select **Server requires authentication**. Then, enter the **Username** and **Password**.

For encrypted email, select **Use TLS encryption**.

In the **Header Fields** area:

- a Select the **To** field and enter the destination email address(es).  
You can specify multiple e-mail addresses by separating each address by a semi-colon.
  - b Select the **From** field and enter the sender email address.
  - c Select the **Subject** field enter the message subject.
  - d Select **Send Test Email** to send a test email using these settings.
- 4 Select the **Send Email** tab:



- a Select the **Attachment Name** field and enter the name of the file that will be attached in the email.
- b From the **Format** drop-down list, select the type of information that will be emailed.

You can select from the same formats that are available when saving files. Settings for the selected format are also the same. See "[Saving Setups, Screen Images, or Data](#)" on page 261.

- c Select **Send Email** to send the file to the server and recipients set up in the Configure tab.

You can also configure the **Setup > (Quick Action)** menu item to e-mail setups, screen images, or data. See "[Configuring the \(Quick Action\) Menu Item](#)" on page 291.

## Recalling Setups, Masks, or Data

- 1 From the main menu, choose **File > Open...**
- 2 In the Open dialog box, from the **Format** drop-down menu, select the type of file you want to recall:
  - **Setup (\*.scp)** – See "[To recall setup files](#)" on page 270.
  - **Mask (\*.msk)** – See "[To recall mask files](#)" on page 270.
  - **Reference Waveform data (\*.h5)** – See "[To recall reference waveform files from a USB storage device](#)" on page 270.
  - **Arbitrary Waveform data (\*.csv)** – See "[To recall arbitrary waveforms](#)" on page 271.
  - **CAN Symbolic data (\*.dbc)** – For CAN serial decode.
  - **LIN Symbolic data (\*.ldf)** – For LIN serial decode.
- 3 Select any options for the type of file you want to recall.
- 4 Use the controls in the bottom of the dialog box to select the file to be recalled.
- 5 Select **Open**.

A message indicating whether the open was successful is displayed.

You can also recall setups and mask files by loading them using the File Explorer. See "[File Explorer](#)" on page 277.

You can also configure the **Setup > (Quick Action)** menu item to recall setups, masks, or reference waveforms. See "[Configuring the \(Quick Action\) Menu Item](#)" on page 291.

### To recall setup files

Setup files can be recalled from internal (\User Files) locations or from an external USB storage device.

- 1 From the main menu, choose **File > Open...**
- 2 In the Open dialog box, from the **Format** drop-down menu, select **Setup (\*.scp)**.
- 3 If you would like to clear the display, select **Clear Display**.
- 4 Use the controls in the bottom of the dialog box to select the file to be recalled.
- 5 Select **Open**.

### To recall mask files

Mask files can be recalled from one of four internal (\User Files) locations or from an external USB storage device.

- 1 From the main menu, choose **File > Open...**
- 2 In the Open dialog box, from the **Format** drop-down menu, select **Mask (\*.msk)**.
- 3 If you would like to clear the display or clear the recalled mask, select **Clear Display** or **Clear Mask**.
- 4 Use the controls in the bottom of the dialog box to select the file to be recalled.
- 5 Select **Open**.

### To recall reference waveform files from a USB storage device

- 1 From the main menu, choose **File > Open...**
- 2 In the Open dialog box, from the **Format** drop-down menu, select **Reference Waveform data (\*.h5)**.
- 3 From the **To Ref:** drop-down list, select the desired reference waveform location.
- 4 If you would like to clear the display of everything except the reference waveform, select **Clear Display**.
- 5 Use the controls in the bottom of the dialog box to select the file to be recalled.
- 6 Select **Open**.

## To recall arbitrary waveforms

Arbitrary waveform files can be recalled from internal (\User Files) locations or from an external USB storage device.

When recalling arbitrary waveforms (from an external USB storage device) that were not saved from the oscilloscope, be aware that:

- If the file contains two columns, the second column is automatically chosen.
- If the file contains more than two columns, you are prompted to select which column to load. Up to five columns are parsed by the oscilloscope; columns above the fifth are ignored.
- The oscilloscope uses a maximum of 8192 points for an arbitrary waveform. For more efficient recalls, make sure your arbitrary waveforms are 8192 points or less.

To recall an arbitrary waveform:

- 1 From the main menu, choose **File > Open...**
- 2 In the Open dialog box, from the **Format** drop-down menu, select **Arbitrary Waveform data (\*.csv)**.
- 3 Use the controls in the bottom of the dialog box to select the file to be recalled.
- 4 Select **Open**.

See Also • ["To edit arbitrary waveforms"](#) on page 254

## Recalling Default Setups

- 1 From the main menu, choose **Control > Default...**
- 2 In the Default dialog box, you can select:
  - **Undo Default Setup** – Returns to the oscilloscope settings that were present before the last **Default Setup**.
  - **Default Setup** – Restores the oscilloscope's default settings. This places the oscilloscope in a known operating condition. See ["Recall the Default Oscilloscope Setup"](#) on page 27.

This is the same as pressing the front panel **[Default Setup]** key.

Some user settings are not changed when recalling the default setup.

- **Default GUI Layout** – Returns to the default graphical user interface (GUI) layout.
- **Factory Default** – Recalls the oscilloscope's factory default settings.

You must confirm the recall because there are no user settings that are left unchanged.

- **Secure Erase** — This performs a secure erase of all non-volatile memory in compliance with National Industrial Security Program Operation Manual (NISPOM) Chapter 8 requirements.

You must confirm the secure erase, and the oscilloscope will reboot when finished.

## Performing a Secure Erase

- 1 From the main menu, choose **Control > Default...**
- 2 In the Default dialog box, select **Secure Erase**.

This performs a secure erase of all non-volatile memory in compliance with National Industrial Security Program Operation Manual (NISPOM) Chapter 8 requirements.

You must confirm the secure erase, and the oscilloscope will reboot when finished.

## 22 Utility Settings

I/O Interface Settings /	273
Setting up the Oscilloscope's LAN Connection /	274
File Explorer /	277
Setting Oscilloscope Preferences /	278
Setting the Oscilloscope's Clock /	281
Setting the Rear Panel AUX OUT Source /	282
Enabling Remote Command Logging /	282
Setting Enhanced Security Options /	283
Performing Service Tasks /	287
Configuring the (Quick Action) Menu Item /	291

This chapter explains oscilloscope utility functions.

### I/O Interface Settings

The oscilloscope can be accessed and/or controlled remotely via these I/O interfaces:

- USB device port on the rear panel (square shaped USB port).
- LAN interface on the rear panel.

When an I/O interface is installed, remote control over that interface is always enabled. Also, the oscilloscope can be controlled via multiple I/O interfaces (for example, USB and LAN) at the same time.

To configure the I/O interfaces:

- 1 From the main menu, choose **Utilities > I/O...**
- 2 In the I/O dialog box, select the **LAN Setup** tab.



- 3 In the LAN Setup tab of the I/O dialog box, you can select:
- **LAN Settings...** – Opens the LAN Settings dialog box where you can set up the oscilloscope's LAN settings. See "[Setting up the Oscilloscope's LAN Connection](#)" on page 274.
  - **LAN Reset** – Resets the oscilloscope's LAN settings.
  - **Turn off LAN Identify** – Turns off the oscilloscope's identification function. The identification function can be turned on via the instrument's web interface, on the Home tab.

Using the oscilloscope's rear panel LAN (local area network) port, you can place the oscilloscope on the network and set up its LAN connection. Once that is done, you can use the oscilloscope's web interface (see [Chapter 23](#), "Web Interface," starting on page 293), or remotely control the oscilloscope via the LAN interface.

#### NOTE

When you connect the oscilloscope to a LAN, it is a good practice to limit access to the oscilloscope by setting a password using the web interface. By default, the oscilloscope is not password protected.

- See Also
- [Chapter 23](#), "Web Interface," starting on page 293 (when the oscilloscope is connected to a LAN).
  - "[Remote Programming via the Web Interface](#)" on page 295
  - The oscilloscope's *Programmer's Guide*.
  - "[Remote Programming with Keysight IO Libraries](#)" on page 296

## Setting up the Oscilloscope's LAN Connection

Using the rear panel LAN port, you can place the oscilloscope on the network and set up its LAN connection. Once that is done, you can use the oscilloscope's web interface or remotely control the oscilloscope via the LAN interface.

The oscilloscope supports methods for automated LAN configuration or manual LAN configuration (see "[To establish a LAN connection](#)" on page 275). It is also possible to set up a point-to-point LAN connection between a PC and the oscilloscope (see "[Stand-alone \(Point-to-Point\) Connection to a PC](#)" on page 276).

Once the oscilloscope is set up on the network, you can use the oscilloscope's web page to view or change its network configuration and access additional settings (like the network password). See **Chapter 23**, "Web Interface," starting on page 293.

**NOTE**

When you connect the oscilloscope to a LAN it is a good practice to limit access to the oscilloscope by setting a password. By default, the oscilloscope is not password protected. See "**Setting a Password**" on page 302 to set a password.

**NOTE**

Any time you modify the oscilloscope's hostname, it breaks the connection between the oscilloscope and the LAN. You need to re-establish communication to the oscilloscope using the new hostname.

## To establish a LAN connection

### Open the LAN Settings Dialog Box

- 1 From the main menu, choose **Utilities > I/O...**
- 2 In the I/O dialog box, select the **LAN Setup** tab.
- 3 Select **LAN Settings...** to open the LAN Settings dialog box.



### Automatic Configuration

- 1 In the LAN Settings dialog box, select **Automatic**.  
If your network supports DHCP or AutoIP, enabling **Automatic** lets the oscilloscope use those services to get its LAN configuration settings
- 2 You can enable the **Multicast DNS** option to let the oscilloscope use Multicast DNS for name resolution on small networks without a conventional DNS server.
- 3 Connect the oscilloscope to the local area network (LAN) by inserting the LAN cable into the "LAN" port on the rear panel of the oscilloscope.

In a few moments the oscilloscope will connect to the network automatically.

If the oscilloscope does not automatically connect to the network, select **LAN Reset** in the I/O dialog box's **LAN Setup** tab. In a few moments the oscilloscope will connect to the network.

**Manual Configuration**

- 1 Get the oscilloscope's network parameters (host name, IP address, subnet mask, gateway IP, DNS IP, etc.) from your network administrator.
- 2 In the LAN Settings dialog box, select and enter values in these fields:
  - **IP Address** – The oscilloscope's IP address.
  - **Subnet Mask** – The oscilloscope's subnet mask.
  - **Gateway IP** – The gateway IP address.
  - **DNS IP** – You can enter the IP address of the Domain Name Server (DNS).
  - **Host Name** – Lets you enter the oscilloscope's hostname.

**NOTE**

Any time you modify the oscilloscope's hostname, it breaks the connection between the oscilloscope and the LAN. You need to re-establish communication to the oscilloscope using the new hostname.

The lower part of the LAN Settings dialog box shows the oscilloscope's **Current LAN Configuration**.

- 3 Select **Apply** to apply the LAN settings changes.

## Stand-alone (Point-to-Point) Connection to a PC

The following procedure describes how to establish a point-to-point (stand alone) connection to the oscilloscope. This is useful if you want to control the oscilloscope using a laptop computer or a stand-alone computer.

- 1 From the main menu, choose **Utilities > I/O...**
- 2 In the I/O dialog box, select the **LAN Setup** tab.
- 3 Select **LAN Settings...**
- 4 In the LAN Settings dialog box, select **Automatic**.

If your network supports DHCP or AutoIP, enabling **Automatic** lets the oscilloscope use those services to get its LAN configuration settings

- 5 Connect your PC to the oscilloscope using a cross-over LAN cable such as Keysight part number 5061-0701, available on the web at [www.keysight.com/find/parts](http://www.keysight.com/find/parts).
- 6 Cycle power on the oscilloscope.

Wait until the LAN connection status shows "configured" in the I/O dialog box's **I/O Overview** tab.

This may take a few minutes.

Now, the instrument is connected, and the instrument's web interface or remote control via LAN may be used.

## File Explorer

The File Explorer lets you navigate the oscilloscope's internal file system and the file systems of connected USB storage devices.

From the internal file system, you can load oscilloscope setup files or mask files.

From a connected USB storage device, you can load setup files, mask files, license files, firmware update (\*.swu) files, label files, etc. Also, you can delete files on a connected USB storage device.

### NOTE

The USB port on the front panel, and the USB port on the rear panel labeled "HOST" are USB Series A ports. These are the ports to which you can connect USB mass storage devices.

The square port on the rear panel labeled "DEVICE" is provided for controlling the oscilloscope over USB. See the *Programmer's Guide* for more information.

The oscilloscope's internal file system, under "\User Files", consists of 10 locations for oscilloscope setup files, four locations for mask files, and four locations for waveform generator arbitrary waveform files.

To use the File Explorer:

- 1 From the main menu, choose **File > File Explorer...** or **Utilities > File Explorer...**
- 2 To navigate in the File Explorer dialog box, select devices, folders, and files.



- 3 When file(s) are selected, you can:
  - Select **Open File** to load the file selected in the bottom portion of the dialog box.
  - Select **Delete File** to delete the file(s) selected in the bottom portion of the dialog box.

- Select **Copy File(s)...** to opens the "Copy File(s) to" dialog box where you can select the destination folder for file(s) selected in the bottom portion of the dialog box.
- 4 To properly unmount a USB storage device before removal, select **Eject**.
- If you remove the device without selecting **Eject** first, the device will be marked as needing repair when connecting to a computer with the Windows operating system (even though there are no harmful effects to the device).

Use your PC to create directories on a USB storage device.

- See Also**
- **Chapter 21**, "Save/Email/Recall (Setups, Screens, Data)," starting on page 261
  - **"USB Storage Devices"** on page 278

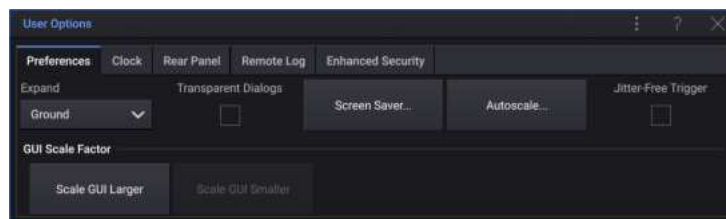
## USB Storage Devices

Most USB mass storage devices are compatible with the oscilloscope. However, certain devices may be incompatible, and may not be able to be read or written to. USB storage devices must be formatted with the FAT/FAT16, FAT32, NTFS, EXT2, EXT3, or EXT4 file system format. The exFAT format is not supported. Any given storage device may not support all of these formats.

You must "eject" a USB mass storage device before unplugging it; otherwise, the device will be marked as needing repair when connecting to a computer with the Windows operating system (even though there are no harmful effects to the device).

Do not connect USB storage devices that identify themselves as hardware type "CD" because these devices are not compatible with the InfiniiVision HD3-Series oscilloscopes.

## Setting Oscilloscope Preferences



The Preferences tab of the User Options dialog box (opened by choosing **Utility > User Options...** from the main menu) lets you specify oscilloscope preferences:

- **"To choose "expand about" center or ground"** on page 279
- **"To disable/enable transparent backgrounds"** on page 279
- **"To set up the screen saver"** on page 279

- **"To set Autoscale preferences"** on page 280
- **"To scale the GUI larger or smaller"** on page 281

## To choose "expand about" center or ground

When you change a channel's volts/division setting, the waveform display can be set to expand (or compress) about the signal ground level or the center of the display.

To set the waveform expansion reference point:

- 1 From the main menu, choose **Utilities > User Options...**
- 2 In the User Options dialog box, select the **Preferences** tab.
- 3 From the **Expand** drop-down list, select:
  - **Ground** – The displayed waveform will expand about the position of the channel's ground. This is the default setting.
 

The ground level of the signal is identified by the position of the ground level (⚡) icon at the far-left side of the display.

The ground level will not move when you adjust the vertical sensitivity (volts/division) control.

If the ground level is off screen, the waveform will expand about the top or bottom edge of the screen based on where the ground is off screen.
  - **Center** – The displayed waveform will expand about the center of the display.

## To disable/enable transparent backgrounds

There is a preference setting for whether measurements, statistics, reference waveform information, and other text displays have transparent or solid backgrounds.

- 1 From the main menu, choose **Utilities > User Options...**
- 2 In the User Options dialog box, select the **Preferences** tab.
- 3 Select **Transparent** to toggle between transparent and solid text display backgrounds.

## To set up the screen saver

The oscilloscope can be configured to turn on a display screen saver when the oscilloscope has been idle for a specified length of time.

- 1 From the main menu, choose **Utilities > User Options...**
- 2 In the User Options dialog box, select the **Preferences** tab.
- 3 Select **Screen Saver...**

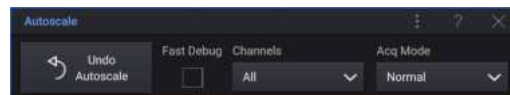
- 4 In the Screen Saver dialog box, from the **Screen Saver** drop-down list, select:



- **Off** – No screen saver is used.
  - **Blank Screen** – A blank screen saver is used.
  - **Keysight Logo** – A screen saver with the Keysight logo is used.
  - **User Text** – A screen saver with user-defined text is used. Enter the text in the **Text** field.
- 5 Select **Wait** and enter the number of minutes to wait before the selected screen saver activates.
  - 6 Select **Preview** to view the selected screen saver.
  - 7 To view the normal display after the screen saver has started, press any key or turn any knob.

### To set Autoscale preferences

- 1 From the main menu, choose **Utilities > User Options...**
- 2 In the User Options dialog box, select the **Preferences** tab.
- 3 Select **Autoscale...**
- 4 In the Autoscale dialog box:



- Select **Undo Autoscale** to return the oscilloscope to settings that were present before the last **Autoscale**.
- Select **Fast Debug** for a quicker autoscale that lets you make quick visual comparisons to determine whether the signal being probed is a DC voltage, ground, or an active AC signal.

Channel coupling is maintained to allow easy viewing of oscillating signals.

- From the **Channels** drop-down list, select the channels to be autoscaled:
  - **All Channels** – The next time you press **[Auto Scale]**, all channels that meet the requirements of Autoscale will be displayed.
  - **Only Displayed Channels** – The next time you press **[Auto Scale]**, only the channels that are turned on will be examined for signal activity. This is useful if you only want to view specific active channels after pressing **[Auto Scale]**.

- From the **Acq Mode** drop-down list, select whether the acquisition mode should be preserved during autoscale:
  - **Normal** – Switches to Normal acquisition mode whenever the **[Auto Scale]** key is pressed. This is the default mode.
  - **Preserve** – Causes the oscilloscope to keep the acquisition mode setting selected when the **[Auto Scale]** key is pressed.

## To scale the GUI larger or smaller

You can select between larger or smaller fonts and dialog boxes in the graphical user interface.

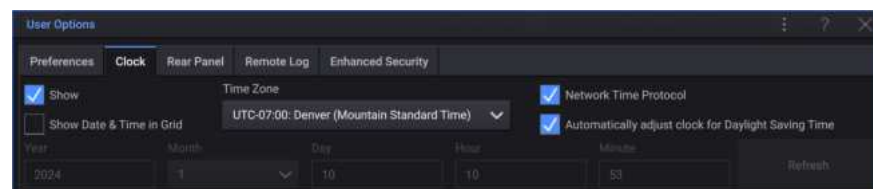
- 1 From the main menu, choose **Utilities > User Options...**
- 2 In the User Options dialog box, select the **Preferences** tab.
- 3 In the **GUI Scale Factor** area, select **Scale GUI Larger** or **Scale GUI Smaller**.

## Setting the Oscilloscope's Clock

Because screen captures and other items show the oscilloscope clock (date/time) settings, you want the oscilloscope clock to be correct. Licenses also rely on correct oscilloscope clock settings.

To set the date and time:

- 1 From the main menu, choose **Utility > User Options...**
- 2 In the User Options dialog box, select the **Clock** tab.
- 3 The Clock tab of the User Options dialog box has these controls for setting up and displaying the oscilloscope's date and time:



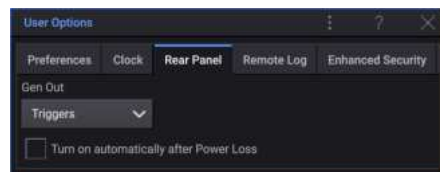
- **Show** – When selected, the oscilloscope's date and time appear on the display.
- **Show Date & Time in Grid** – When selected, the oscilloscope's date and time appear in the first waveform grid; otherwise, the date and time appear in the badges bar at the top of the display.
- **Time Zone** – Select the oscilloscope's time zone.
- **Network Time Protocol** – The oscilloscope's time is synchronized with the network time.

- **Automatically adjust clock for Daylight Savings Time** – When selected, the oscilloscope's time automatically adjusts during Daylight Savings Time.
- **Year, Month, Day, Hour, Minute** – When not synchronized with the network time, you can enter these values.
- **Refresh** – Updates the oscilloscope's date and time display with setting changes.

## Setting the Rear Panel AUX OUT Source

You can choose the source of the AUX OUT BNC connector on the rear panel of the oscilloscope:

- 1 From the main menu, choose **Utility > User Options...**
- 2 In the User Options dialog box, select the **Rear Panel** tab.



- 3 From the **Aux Out** drop-down list, select:
  - **Triggers** – Each time the oscilloscope triggers, a rising edge occurs on AUX OUT. The rising edge is delayed 1.06  $\mu\text{s}$  from the oscilloscope's trigger point. The output level is 0-5 V into an open circuit, and 0-2.5 V into 50  $\Omega$ . See [Chapter 10](#), “Triggers,” starting on page 135.
  - **Mask** – The pass/fail status is evaluated periodically. When the evaluation of the testing period results in a failure, the trigger output pulses high (+5 V). Otherwise, the trigger output remains at low (0 V). See [Chapter 16](#), “Mask Testing,” starting on page 221.
  - **Waveform Generator Sync Pulse** – All of the waveform generator output functions (except DC, Noise, and Cardiac) have an associated Sync signal:
 

The Sync signal is a TTL positive pulse that occurs when the waveform rises above zero volts (or the DC offset value).

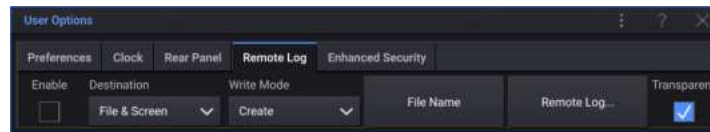
See [Chapter 20](#), “Waveform Generator,” starting on page 249.

## Enabling Remote Command Logging

When remote command logging is enabled, remote commands sent to the instrument (and results returned by the instrument) can be logged to the screen, to a text file on a USB storage device, or to both the screen and a text file.

To enable remote command logging:

- 1 From the main menu, choose **Utilities > User Options...**
- 2 In the User Options dialog box, select the **Remote Log** tab.



- 3 Select **Enable** to enable or disable the remote command logging feature.

When remote logging is enabled, additional debug information can be included in the returned error string. If the error is detected by the SCPI command parser, such as a header error or other syntax error, the extra debug information is generated and included. But if the error is detected by the oscilloscope system, such as when an out-of-range value is sent, then no extra debug information is included.

- 4 From the **Destination** drop-down list, select whether remote commands are logged to a text file (on a connected USB storage device), logged to the screen, or both.
- 5 From the **Write Mode** drop-down list, select whether logged commands will be created in a new list or appended to existing logged commands.

Your selection takes effect when remote command logging is enabled.

This option applies to both screen and file logging.

- 6 Select **File Name** to open the Remote Log Filename dialog box where you can specify the name of the file (on the USB storage device) to which remote commands are logged.
- 7 Select **Remote Log** to open the Remote Log dialog box that contains the logged commands.
- 8 Select **Transparent** to disable or enable a transparent background for the Remote Log dialog box.

Enable to make the background transparent. This lets you view underlying waveforms.

Disable for a solid background which makes the logged remote commands easier to read.

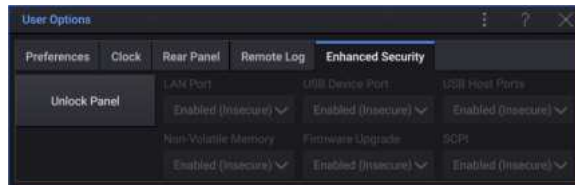
## Setting Enhanced Security Options

With the Enhanced Security license, you can disable features to further secure the oscilloscope.

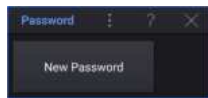
A password is required to make enhanced security changes.

To make enhanced security changes:

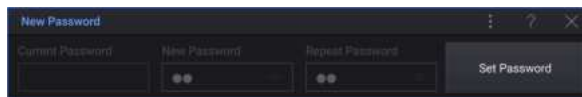
- 1 From the main menu, choose **Utilities > User Options...**
- 2 In the User Options dialog box, select the **Enhanced Security** tab.



- 3 Select **Unlock Panel**.
- 4 If you are setting the password for the first time:
  - a In the Password dialog box, select **New Password**.



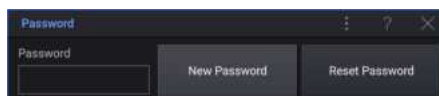
- b In the New Password dialog box, select the **New Password** field and enter the new password.
    - c Select the **Repeat Password** field and re-enter the new password.



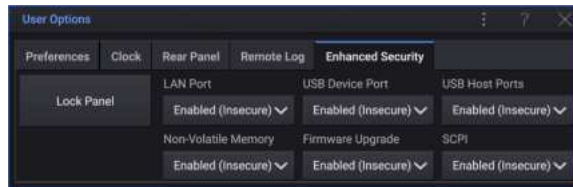
- d Select **Set Password**.
    - e In the confirmation dialog, read the warning information. Then, select **OK**.

If there is an existing password:

- a In the Password dialog box, select the **Password** field and enter the existing password.



Once a password is set or entered, you are automatically taken back to the unlocked Enhanced Security tab where you can change these options:



<p><b>LAN Port</b></p>	<p>Use this drop-down list to disable or enable the oscilloscope's LAN port. The LAN port lets you access the oscilloscope's built-in web interface and issue remote commands.</p> <p>When the LAN port is disabled, the oscilloscope cannot be pinged and is essentially invisible over Ethernet to any device, even if an Ethernet cable is plugged into the oscilloscope's LAN port.</p>
<p><b>USB Device Port</b></p>	<p>Use this drop-down list to disable or enable the oscilloscope's USB Device port. The USB Device port is the square shaped USB port for connecting the oscilloscope to a host PC for remote communication.</p>
<p><b>USB Host Ports</b></p>	<p>Use this drop-down list to disable or enable the oscilloscope's USB Host ports. The USB Host ports are the rectangular shaped USB ports used for connecting a USB mass storage device, printer, mouse, or keyboard to the oscilloscope.</p>
<p><b>Non-Volatile Memory</b></p>	<p>Use this drop-down list to disable or enable the oscilloscope's non-volatile memory. The contents of non-volatile memory are kept when the oscilloscope is powered off.</p> <p>Normally, the oscilloscope's internal storage for setup files, mask files, and arbitrary waveforms (under "User files") and for symbolic decoding files, etc., is non-volatile; however, when the non-volatile memory is disabled, this internal storage becomes volatile and is not kept when the oscilloscope is powered off.</p> <p>Also, when non-volatile memory is disabled:</p> <ul style="list-style-type: none"> <li>▪ The oscilloscope is restored to a factory default setup when powered on.</li> <li>▪ Licenses and calibration factors, which are not user-accessible, are retained.</li> <li>▪ Web-based firmware upgrades are disabled, even if the oscilloscope's LAN Port and Firmware Upgrade options are enabled.</li> </ul>
<p><b>Firmware Upgrade</b></p>	<p>Use this drop-down list to disable or enable the ability to upgrade firmware.</p> <p>When firmware upgrades are disabled:</p> <ul style="list-style-type: none"> <li>▪ Firmware installers (.swu files) are prevented from being loaded into, or run in, the oscilloscope. This applies to firmware upgrades from external USB mass storage devices as well as web-based firmware upgrades.</li> <li>▪ Licenses can still be installed</li> <li>▪ Recallable files (setup files, mask files, etc.) can still be accessed from external media if the appropriate communication ports are enabled.</li> </ul> <p>Note that web-based firmware upgrades are disabled when non-volatile memory is disabled, even when this and the LAN Port options are enabled.</p>
<p><b>SCPI</b></p>	<p>Use this drop-down list to disable or enable the ability to send SCPI commands and queries to the oscilloscope over LAN or USB connections.</p>

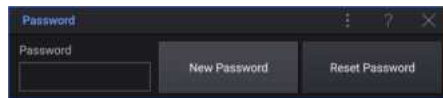
Disabled settings are secure, and enabled settings are insecure.

When changing the non-volatile memory, **LAN Port**, **USB Device Port**, or **USB Host Ports** settings, you must reboot the oscilloscope for the change to take place.

Select **Lock Panel** to lock the enhanced security options panel.

To change the enhanced security password:

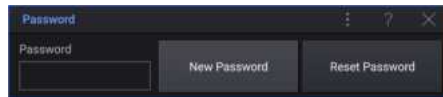
- 1 From the main menu, choose **Utilities > User Options...**
- 2 In the User Options dialog box, select the **Enhanced Security** tab.
- 3 Select **Unlock Panel**.
- 4 In the Password dialog box, select **New Password**.



- 5 In the New Password dialog box, select the **Current Password** field and enter the existing password.
- 6 Select the **New Password** field and enter the new password.
- 7 Select the **Repeat Password** field and re-enter the new password.
- 8 Select **Set Password**.
- 9 In the confirmation dialog, read the warning information. Then, select **OK**.

To reset (clear) the enhanced security password:

- 1 From the main menu, choose **Utilities > User Options...**
- 2 In the User Options dialog box, select the **Enhanced Security** tab.
- 3 Select **Unlock Panel**.
- 4 In the Password dialog box, select **Reset Password**.



- 5 In the Reset Password dialog box, select the **Current Password** field and enter the existing password.
- 6 Select **Reset Password**.
- 7 In the confirmation dialog, select **OK**.

## Performing Service Tasks

The Service dialog box (choose **Utilities > Service...** from the main menu) lets you perform service-related tasks:

- **"To display the user calibration status"** on page 287
- **"To perform user calibration"** on page 288
- **"To perform hardware self test"** on page 288
- **"To perform front panel self test"** on page 289
- **"To display oscilloscope information"** on page 290

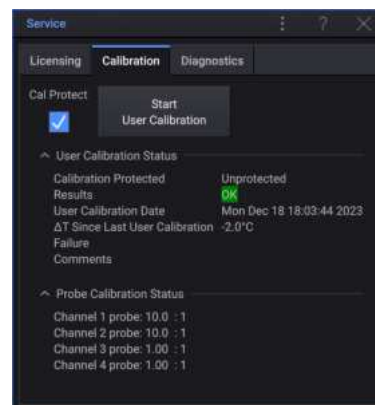
For other information related to oscilloscope maintenance and service, see:

- **"To clean the oscilloscope"** on page 290
- **"To check warranty and extended services status"** on page 290
- **"To contact Keysight"** on page 290
- **"To return the instrument"** on page 291

### To display the user calibration status

To display the summary results of the previous User Calibration and the status of probe calibrations for probes that can be calibrated:

- 1 From the main menu, choose **Utilities > Service...**
- 2 In the Service dialog box, select the **Calibration** tab.



Note that passive probes do not need to be calibrated, but InfiniiMax probes can be calibrated. For more information about calibrating probes see **"To calibrate a probe"** on page 62.

## To perform user calibration

Perform user-calibration:

- Every three years or after 6000 hours of operation.
- If the ambient temperature is  $>10^{\circ}$  C from the calibration temperature.
- If you want to maximize the measurement accuracy.

The amount of use, environmental conditions, and experience with other instruments help determine if you need shorter User Calibration intervals.

User Calibration performs an internal self-alignment routine to optimize the signal path in the oscilloscope. The routine uses internally generated signals to optimize circuits that affect channel sensitivity, offset, and trigger parameters.

Performing User Calibration will invalidate your Certificate of Calibration. If NIST (National Institute of Standards and Technology) traceability is required, perform the "Performance Verification" procedure in the *Service Guide* using traceable sources.

To perform user calibration:

- 1 Disconnect all inputs from the front and rear panels, including the digital channels cable. Disconnect the waveform generator output. No cables are needed.

### CAUTION

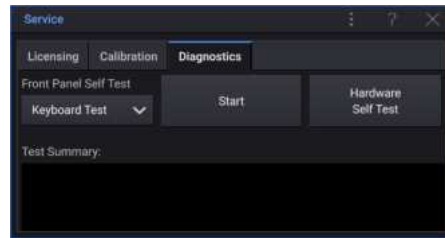
Disconnecting oscilloscope inputs and the waveform generator output before user calibration is important because the oscilloscope's measurement accuracy depends on proper calibration.

- 2 Allow the oscilloscope to warm up 30 minutes before performing this procedure.
- 3 From the main menu, choose **Utilities > Service...**
- 4 In the Service dialog box, select the **Calibration** tab.
- 5 Clear the **Cal Protect** check box.
- 6 Select **Start User Calibration**.

## To perform hardware self test

To perform a series of internal procedures to verify that the oscilloscope is operating properly:

- 1 From the main menu, choose **Utilities > Service...**
- 2 In the Service dialog box, select the **Diagnostics** tab.



### 3 Select **Hardware Self Test**.

It is recommended you run Hardware Self Test:

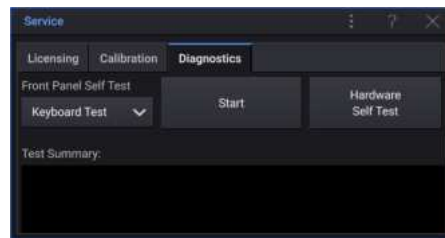
- After experiencing abnormal operation.
- For additional information to better describe an oscilloscope failure.
- To verify proper operation after the oscilloscope has been repaired.

Successfully passing Hardware Self Test does not guarantee 100% of the oscilloscope's functionality. Hardware Self Test is designed to provide an 80% confidence level that the oscilloscope is operating properly.

## To perform front panel self test

To test the front panel keys and knobs, LEDs, display, and touch screen:

- 1 From the main menu, choose **Utilities > Service....**
- 2 In the Service dialog box, select the **Diagnostics** tab.



### 3 From the **Front Panel Self Test** drop-down list, select the test you want to perform:

- **Keyboard Test** – Tests the front panel keys and knobs.
- **LED Test** – Test the front panel LEDs.
- **Display Test** – Tests the display's ability to output basic colors.
- **Touch Screen Test** – Tests the touch screen.

### 4 Select **Start**.

Follow the on-screen instructions.

When the test is complete, status information appears in the **Test Summary** box.

## To display oscilloscope information

From the main menu, choose **Help > About This Oscilloscope....** The About dialog box contains information about your oscilloscope:

- Model number.
- Serial number.
- Bandwidth.
- Host ID.
- Module installed.
- Firmware version.
- Installed licenses. See also "**Loading Licenses and Displaying License Information**" on page 308.

## To clean the oscilloscope

- 1 Remove power from the instrument by shutting down and disconnecting the power cord.
- 2 Clean the external surfaces of the oscilloscope with a soft cloth dampened with a mixture of mild detergent and water.
- 3 Make sure that the instrument is completely dry before reconnecting it to a power source.

## To check warranty and extended services status

To learn the warranty status of your oscilloscope:

- 1 Point your web browser to: [www.keysight.com/find/warrantystatus](http://www.keysight.com/find/warrantystatus)
- 2 Enter your product's model number and serial number. The system will search for the warranty status of your product and display the results. If the system cannot find your product's warranty status, select **Contact Us** and speak with a Keysight Technologies representative.

## To contact Keysight

Information on contacting Keysight Technologies can be found at:  
[www.keysight.com/find/contactus](http://www.keysight.com/find/contactus)

## To return the instrument

Before shipping the oscilloscope to Keysight Technologies, contact your nearest Keysight Technologies sales or service office for additional details. Information on contacting Keysight Technologies can be found at:

[www.keysight.com/find/contactus](http://www.keysight.com/find/contactus)

- 1 Write the following information on a tag and attach it to the oscilloscope.
  - Name and address of owner.
  - Model number.
  - Serial number.
  - Description of service required or failure indication.

- 2 Remove accessories from the oscilloscope.

Only return accessories to Keysight Technologies if they are associated with the failure symptoms.

- 3 Package the oscilloscope.

You can use the original shipping container, or provide your own materials sufficient to protect the instrument during shipping.

- 4 Seal the shipping container securely, and mark it FRAGILE.

## Configuring the (Quick Action) Menu Item

The **Setup > (Quick Action)** menu item lets you quickly perform common, repetitive actions. The **(Quick Action)** menu item can also be added to the Favorites menu for even faster access.

To configure the **(Quick Action)** menu item:

- 1 From the main menu, choose **Setup > Quick Action Setup...**
- 2 From the Quick Action Setup dialog box's **Action** drop-down list, select:
  - **Off** – disables the **(Quick Action)** menu item.
  - **Quick Measure** – quickly adds 10 common measurements. The **Source** pull-down list lets you select the waveform source (which also becomes the source selection in the Measurements dialog box). See "[To quickly add 10 common measurements](#)" on page 186.
  - **Quick Measure Statistics Reset** – resets all measurement statistics and the measurement count. See "[Measurement Statistics](#)" on page 209.
  - **Quick Mask Statistics Reset** – resets mask statistics and counters. See "[Mask Statistics](#)" on page 225.
  - **Quick Histogram Statistics Reset** – resets all histogram statistics. See "[Histogram Data Statistics](#)" on page 219.

- **Quick Save** – saves the current image, waveform data, or setup. Press **Settings** to set up the save options. See **Chapter 21**, “Save/Email/Recall (Setups, Screens, Data),” starting on page 261.
- **Quick Email** – e-mails the current setup, screen image, or data file. Press **Settings** to set up the e-mail options. See **"Emailing Setups, Screen Images, or Data"** on page 267.
- **Quick Recall** – recalls a setup, mask, or reference waveform. Press **Settings** to set up the recall options. See **Chapter 21**, “Save/Email/Recall (Setups, Screens, Data),” starting on page 261.
- **Quick Trigger Mode** – toggles the trigger mode between Auto and Trig'd, see **"To select the Auto or Trig'd trigger mode"** on page 154.
- **Quick Clear Display** – clears the display, see **"To clear the display"** on page 126.

Once the **(Quick Action)** menu item is configured, choose **Setup > (Quick Action)** to perform the selected action.

## 23 Web Interface

Accessing the Web Interface / 294

Control Instrument / 295

Get Image / 297

Save/Recall / 298

Identification Function / 300

Instrument Utilities / 301

Setting a Password / 302

When Keysight InfiniiVision HD3-Series oscilloscopes are set up on the LAN, you can access the oscilloscope's built-in web server using a web browser. The oscilloscope's web interface lets you:

- View information about the oscilloscope like its model number, serial number, host name, IP address, and VISA (address) connect string.
- Send SCPI (Standard Commands for Programmable Instrumentation) remote programming commands via the SCPI Commands applet window.
- Control the oscilloscope's graphical user interface using a remote VNC (Virtual Network Computing) client.
- Get screen images and save or print them from the browser.
- Save setup files, mask files, screen images, or Reference waveform data.
- Recall setup files, mask files, or Reference waveform data.
- Activate the Identification function to identify a particular instrument by causing a message to be displayed or a front panel light to blink.
- View installed options, view firmware versions and install firmware upgrade files, install license files, and view calibration status (via the Instrument Utilities page).
- View and modify the oscilloscope's network configuration.

The web interface for InfiniiVision HD3-Series oscilloscopes also provides help for each of its pages.

Before you can use the web interface, you must place the oscilloscope on the network and set up its LAN connection.

## Accessing the Web Interface

To access the oscilloscope's web interface:

- 1 Connect the oscilloscope to your LAN (see **"To establish a LAN connection"** on page 275) or establish a point-to-point connection (see **"Stand-alone (Point-to-Point) Connection to a PC"** on page 276).

It is possible to use a point-to-point connection, but using a normal LAN connection is the preferred method.

- 2 Type the oscilloscope's hostname or IP address in the web browser.

The oscilloscope's web interface Welcome Page is displayed.

**KEYSIGHT TECHNOLOGIES** HD304MSO Oscilloscope  
Serial number: Unset

Home Control Instrument Get Image Save Recall Instrument Utilities Configure LAN

Connected to HD304MSO Oscilloscope at IP address 141.121.233.111

Enable front panel identification indicator

**Description**

Model number	HD304MSO
Manufacturer	Keysight Technologies
Serial number	Unset
Firmware revision	10.00.2024062337
Description	

**VISA instrument addresses**

HISLIP LAN protocol	TCPIP::141.121.233.111::hislip0::INSTR
VXI-11 LAN protocol	TCPIP::141.121.233.111::inst0::INSTR
GPIB over LAN protocol	TCPIP::141.121.233.111::inst0::INSTR
TCP/IP SOCKET protocol	TCPIP::141.121.233.111::5025::SOCKET
TCP/IP TELNET protocol	TCPIP::141.121.233.111::5024::SOCKET
USB (USBTMC/488)	USB0::10893::18180::Unset::0::INSTR

▼ More Information

© Keysight Technologies 2024 | Support | Product | Keysight

## Control Instrument

The web interface's Instrument Control page gives you access to the SCPI Command window applet for Remote Programming (see "[Remote Programming via the Web Interface](#)" on page 295).

Also, the HD3-Series oscilloscopes support remote access to the graphical user interface using VNC (Virtual Network Computing) client software (see "[Remote GUI Access Using VNC](#)" on page 297).

### Remote Programming via the Web Interface

**NOTE**

If Java is not installed on your PC, you will be prompted to install the Java Plug-in. This plug-in must be installed on the controlling PC for the web interface's Remote Programming operations.

The SCPI Command window is useful for testing commands or entering a few commands interactively. When creating automated programs for controlling the oscilloscope, you will typically use the Keysight IO Libraries from within a programming environment like Microsoft Visual Studio (see "[Remote Programming with Keysight IO Libraries](#)" on page 296).

To send remote programming commands to the oscilloscope via the SCPI Commands applet window:

- 1 Access the oscilloscope's web interface (see "[Accessing the Web Interface](#)" on page 294).
- 2 When the oscilloscope's web interface is displayed, select the **Control Instrument** tab, then select **Use Instrument IO**.

The SCPI Commands applet appears within the browser web page.

**KEYSIGHT TECHNOLOGIES** HD304MSO Oscilloscope  
Serial number: Unset

Home Control Instrument Get Image Save Recall Instrument Utilities Configure LAN

### Instrument IO

Send remote programming (SCPI) commands and queries to the instrument and view the responses returned by the instrument.

**Command**

\*IDN? Execute Commands

**Response history**

```
SENT: *IDN?
READ: KEYSIGHT TECHNOLOGIES,HD304MSO,Unset,10.00.2024062337
-----
```

Reconnect Copy history Clear history

Options

© Keysight Technologies 2024 | [Support](#) | [Product](#) | [Keysight](#)

## Remote Programming with Keysight IO Libraries

While the SCPI Commands applet window lets you enter and remote programming commands, remote programming for automated test and data acquisition is typically done using the Keysight IO Libraries, which are separate from the instrument's web interface.

The Keysight IO Libraries let a controller PC communicate with Keysight InfiniiVision oscilloscopes via their USB or LAN interfaces.

The Keysight IO Libraries Suite connectivity software enables communication over these interfaces. You can download the Keysight IO Libraries Suite from [www.keysight.com/find/iolib](http://www.keysight.com/find/iolib).

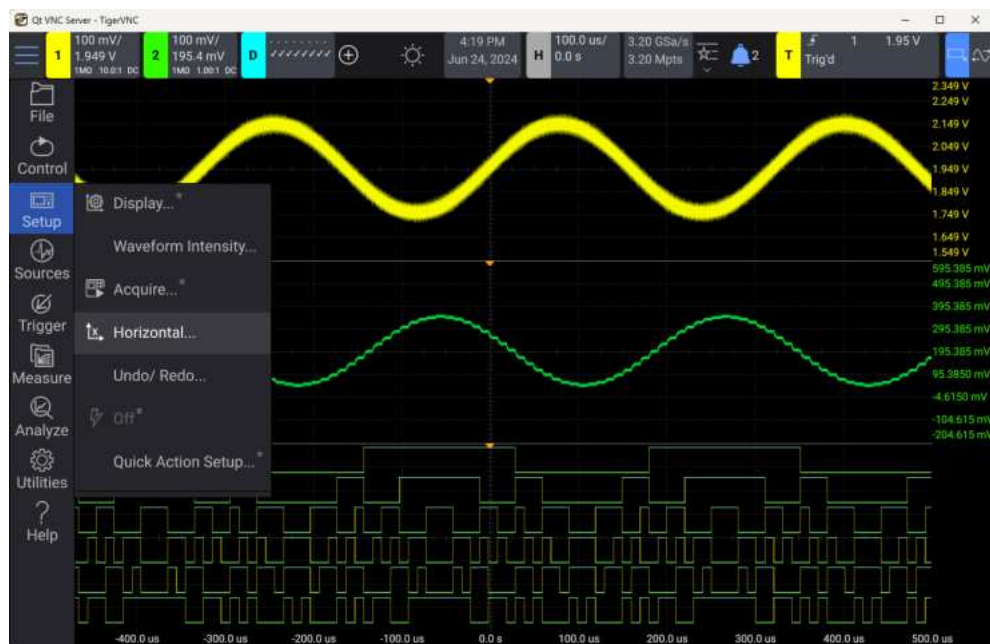
Information about controlling the oscilloscope through remote commands is contained in the *Programmer's Guide*.

For more information about connecting to the oscilloscope, refer to the *Keysight Technologies USB/LAN/GPIB Interfaces Connectivity Guide*. For a printable electronic copy of the *Connectivity Guide*, direct your Web browser to [www.keysight.com](http://www.keysight.com) and search for "Connectivity Guide".

## Remote GUI Access Using VNC

To access the oscilloscope's graphical user interface (GUI) on a remote computer using VNC (Virtual Network Computing) client software:

- 1 If VNC viewer software is not installed on your remote computer, do that first.
- 2 Run the VNC viewer software.
- 3 Give the oscilloscope's hostname or IP address as the name of the VNC server to connect with.
- 4 Connect.
- 5 Once the VNC viewer connection opens, you can interact with the oscilloscope's GUI like you would on the oscilloscope.



## Get Image

To save (or print) the oscilloscope's display from the web interface:

- 1 Access the oscilloscope's web interface (see "[Accessing the Web Interface](#)" on page 294).
- 2 When the oscilloscope's web interface is displayed, select the **Get Image** tab. After a delay of several seconds, the oscilloscope's screen image will be displayed.  
Click **Refresh Image** to get an updated screen image.
- 3 Right-click on the image and select **Save Picture As...** (or **Print Picture...**).

- 4 Select a storage location for the image file and click **Save**.

## Save/Recall

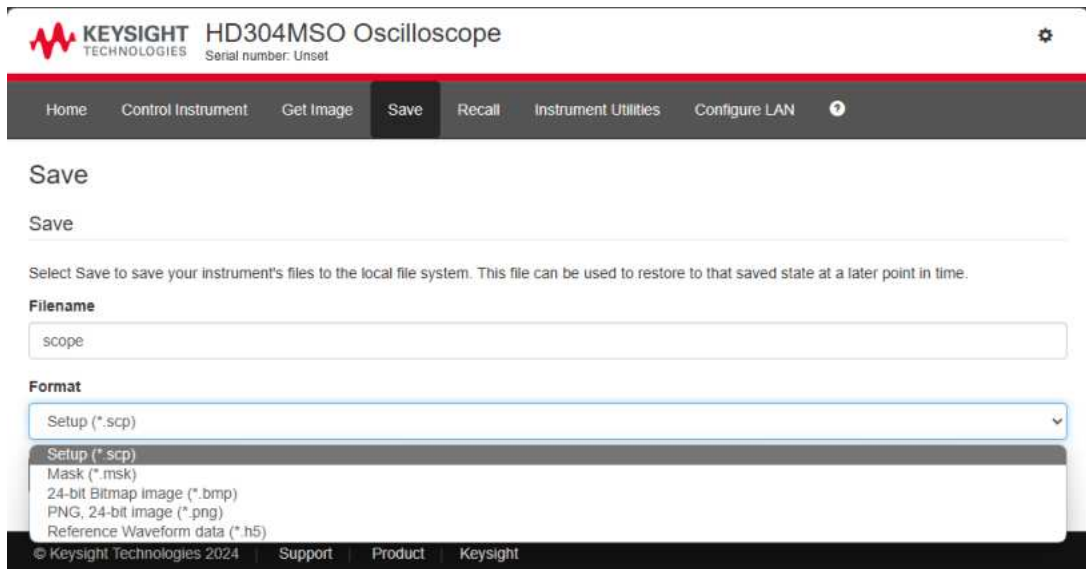
You can save setup files, mask files, screen images, or Reference waveform data to your PC via the oscilloscope's web interface (see "[Saving Files via the Web Interface](#)" on page 298).

You can recall setup files, mask files, or Reference waveform data from your PC via the oscilloscope's web interface (see "[Recalling Files via the Web Interface](#)" on page 299).

### Saving Files via the Web Interface

To save setup files, mask files, screen images, or Reference waveform data to your PC via the oscilloscope's web interface:

- 1 Access the oscilloscope's web interface (see "[Accessing the Web Interface](#)" on page 294).
- 2 When the oscilloscope's web interface is displayed, select the **Save** tab.
- 3 On the Save page:
  - a Enter the name of the file you are saving to.
  - b Select the format.



You can click **Preview** to view the oscilloscope's current screen image.

With some formats, you can click **Save Setup Info** to save setup information to an ASCII .txt format file.

- c Click **Save**.

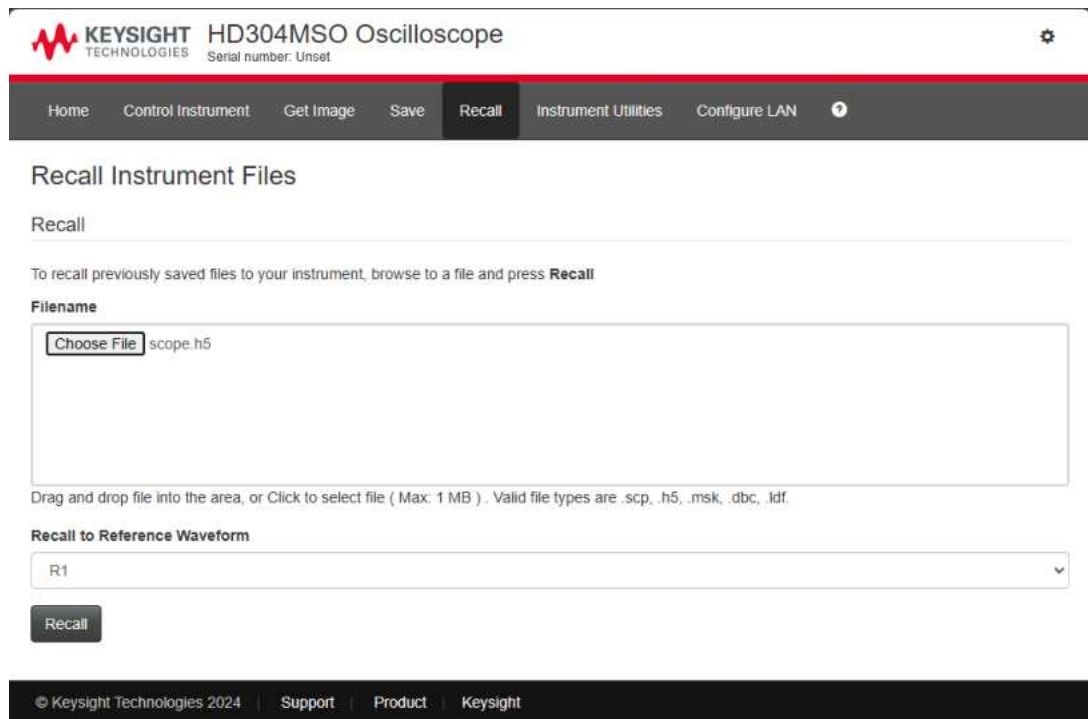
The selected information is saved.

- d In the File Download dialog, click **Save**.
- e In the Save As dialog, navigate to the folder where you want to save the file; then, click **Save**.

## Recalling Files via the Web Interface

To recall setup files, mask files, screen images, or Reference waveform data from your PC via the oscilloscope's web interface:

- 1 Access the oscilloscope's web interface (see "**Accessing the Web Interface**" on page 294).
- 2 When the oscilloscope's web interface is displayed, select the **Recall** tab.
- 3 On the Recall page:
  - a Click **Browse...**
  - b In the "Choose file" dialog, select the file you want to recall; then, click **Recall**.
  - c When recalling reference waveform data files, select the **Recall to Reference Waveform** option.



d Click **Recall**.

## Identification Function

The Identification web interface feature is useful when trying to locate a specific instrument in a rack of equipment.

- 1 Access the oscilloscope's web interface (see "[Accessing the Web Interface](#)" on page 294).
- 2 When the oscilloscope's web interface Welcome Page is displayed, select the **Enable front panel identification indicator** check box.

An "Identify" status dialog box is displayed on the oscilloscope.

You can either clear the **Enable front panel identification indicator** check box or close the dialog box on the oscilloscope to continue.



KEYSIGHT TECHNOLOGIES HD304MSO Oscilloscope  
Serial number: Unset

Home Control Instrument Get Image Save Recall Instrument Utilities Configure LAN

Connected to HD304MSO Oscilloscope  
at IP address 141.121.233.111

Enable front panel identification indicator

Identification option

## Instrument Utilities

The Instrument Utilities page of the web interface lets you:

- View installed options.
- View firmware versions.
- Install firmware upgrade files.
- Install license files.
- View calibration status.

You can select these capabilities via a drop-down menu.

**KEYSIGHT TECHNOLOGIES** HD304MSO Oscilloscope  
Serial number: Unset

Home Control Instrument Get Image Save Recall **Instrument Utilities** Configure LAN

### Instrument Utilities

Installed Options

Installed Options  
Firmware Version  
Calibration Status

Support ID: HD304MSO,Unset

Model	Description	Installed	Trial Expiration
HD3SECURE	Enhanced Security Software Option for HD300	Yes	N/A
HD3WAVEGEN	WaveGen Software for HD300	Yes	N/A
HD300AUTA	Automotive Analysis Software for HD300	Yes	N/A
HD300EMBA	Embedded Protocol Analysis Software for HD300	Yes	N/A
MEMUP100	Acq Memory 100M	Yes	N/A
MEMUP50	Acq Memory 50M	Yes	N/A
MEMUP20	Acq Memory 20M	Yes	N/A
BW1000	1GHz Bandwidth	Yes	N/A
BW500	500MHz Bandwidth	Yes	N/A
BW350	350MHz Bandwidth	Yes	N/A
BW200	200MHz Bandwidth	Yes	N/A
DIS	Distributor License	No	N/A
D24	Demo 24 Month License for HD300	No	N/A

Load New License

To install a new option, browse to a license file and press **Install**

Filename

Choose Files No file chosen

## Setting a Password

Whenever you connect the oscilloscope to a LAN, it is good practice to set a password. The password prevents someone from remotely accessing the oscilloscope via a Web browser and modifying its settings. Remote users can still view the Welcome screen, view network status, etc., but they cannot modify instrument settings without the password.

To set a password:

- 1 Access the oscilloscope's web interface (see "[Accessing the Web Interface](#)" on page 294).
- 2 When the oscilloscope's web interface is displayed, select the gear icon in the upper-right corner of the web page.
- 3 Click the **Enable password** button.
- 4 Enter your desired password in the **New Password** field. Enter the password again in the **Confirm Password** field. Click **Enable Password**.

When a password is enabled for the web interface, **Log out** or **Log in** appears in the upper-right corner next to the gear icon.

To change or disable the password

Do one of these things:

- Select the gear icon in the upper-right corner of the web page. In the Password Options page, click **Change Password** or **Disable Password**.
- Another way to disable the password is to reset the oscilloscope's LAN settings. To do this, select the **Configure LAN** tab, select **Advanced options**, and select **LAN Reset**.
- You can also reset the oscilloscope's LAN settings from the oscilloscope's graphical user interface:
  - a Choose **Utility > I/O...**
  - b In the I/O dialog box, select the **LAN Setup** tab.
  - c Select **LAN Reset**.



## 24 Reference

Specifications and Characteristics /	305
Measurement Category /	305
Environmental Conditions /	307
Probes and Accessories /	307
Loading Licenses and Displaying License Information /	308
Software and Firmware Updates /	308
Binary Data (.bin) Format /	309
CSV and ASCII XY files /	315
Acknowledgements /	316
Product Markings and Regulatory Information /	317

### Specifications and Characteristics

Please see the InfiniiVision oscilloscope data sheets for complete, up-to-date specifications and characteristics. To download a data sheet, please visit:  
[www.keysight.com/find/HD3-Series](http://www.keysight.com/find/HD3-Series)

### Measurement Category

- "[Oscilloscope Measurement Category](#)" on page 305
- "[Measurement Category Definitions](#)" on page 306
- "[Maximum Input Voltages](#)" on page 306

### Oscilloscope Measurement Category

The InfiniiVision oscilloscopes are not intended to be used for measurements in Measurement Category II, III, or IV.

#### **WARNING**

**Use this instrument only for measurements within its specified measurement category (not rated for CAT II, III, IV). No transient overvoltages allowed.**

## Measurement Category Definitions

The "Not rated for CAT II, III, IV" measurement category is for measurements performed on circuits not directly connected to MAINS. Examples are measurements on circuits not derived from MAINS, and specially protected (internal) MAINS derived circuits. In the latter case, transient stresses are variable; for that reason, the transient withstand capability of the equipment is made known to the user.

Measurement category II is for measurements performed on circuits directly connected to the low voltage installation. Examples are measurements on household appliances, portable tools and similar equipment.

Measurement category III is for measurements performed in the building installation. Examples are measurements on distribution boards, circuit-breakers, wiring, including cables, bus-bars, junction boxes, switches, socket-outlets in the fixed installation, and equipment for industrial use and some other equipment, for example, stationary motors with permanent connection to the fixed installation.

Measurement category IV is for measurements performed at the source of the low-voltage installation. Examples are electricity meters and measurements on primary overcurrent protection devices and ripple control units.

## Maximum Input Voltages

### CAUTION

#### Maximum input voltage at analog inputs

135 Vrms

50Ω input: 5 Vrms Input protection is enabled in 50 Ω mode and the 50 Ω load will disconnect if greater than 5 Vrms is detected. However the inputs could still be damaged, depending on the time constant of the signal. The 50 Ω input protection only functions when the oscilloscope is powered on.

---

### CAUTION

When measuring voltages over 80 V, use a 10:1 probe.

---

### CAUTION

#### Maximum input voltage at digital channels

±40 V peak

---

## Environmental Conditions

Environment	Indoor use only.
Ambient temperature	0 to 50 °C
Humidity	Maximum Relative Humidity (non-condensing): 95% RH up to 40 °C From 40 °C to 50 °C, the maximum % Relative Humidity follows the line of constant dew point
Altitude	3,000 m max
Overvoltage Category	This product is intended to be powered by MAINS that comply to Overvoltage Category II, which is typical of cord-and-plug connected equipment.
Pollution Degree	The InfiniiVision HD3-Series oscilloscopes may be operated in environments of Pollution Degree 2 (or Pollution Degree 1).
Pollution Degree Definitions	<p>Pollution Degree 1: No pollution or only dry, non-conductive pollution occurs. The pollution has no influence. Example: A clean room or climate controlled office environment.</p> <p>Pollution Degree 2. Normally only dry non-conductive pollution occurs. Occasionally a temporary conductivity caused by condensation may occur. Example: General indoor environment.</p> <p>Pollution Degree 3: Conductive pollution occurs, or dry, non-conductive pollution occurs which becomes conductive due to condensation which is expected. Example: Sheltered outdoor environment.</p>

## Probes and Accessories

For a list of the probes and accessories that are compatible with the HD3-Series oscilloscopes, see the data sheet at: [www.keysight.com/find/HD3-Series](http://www.keysight.com/find/HD3-Series)

**AutoProbe Interface** Most Keysight single-ended active, differential, and current probes are compatible with the AutoProbe interface. Active probes that do not have their own external power supply require substantial power from the AutoProbe interface.

If too much current is drawn from the AutoProbe interface, an error message will be displayed, indicating that you must momentarily disconnect all probes to reset the AutoProbe interface, then connect only the supported quantity of active probes.

**See Also** For more information on probes and accessories, see [www.keysight.com](http://www.keysight.com) for:

- [Probes and Accessories Selection Guide \(5989-6162EN\)](#)
- [InfiniiVision Oscilloscope Probes and Accessories Selection Guide Data Sheet \(5968-8153EN\)](#)

- For compatibility information, manuals, application notes, data sheets, selection guides, SPICE models, and more for oscilloscope probes, see the Probe Resource Center at: [www.keysight.com/find/PRC](http://www.keysight.com/find/PRC)

## Loading Licenses and Displaying License Information

License files are loaded from a USB storage device using the File Explorer (see "[File Explorer](#)" on page 277).

License information is displayed with other oscilloscope information (see "[To display oscilloscope information](#)" on page 290).

For more information about the licenses and other oscilloscope options available, see:

- "[Licensed Options Available](#)" on page 308
- "[Other Options Available](#)" on page 308

### Licensed Options Available

The following licensed options can be easily installed without returning the oscilloscope to a Service Center. See data sheets for details.

**Table 2** Licensed Options Available

License	Description	Upgrade model number, notes
HDD300AUTA	Automotive Serial Triggering and Analysis for HD3-Series	Order HD300AUTA.
HDD300EMBA	Embedded Serial Triggering and Analysis for HD3-Series	Order HD300EMBA.

### Other Options Available

**Table 3** Calibration Option

Option	Order
1A7	17025 Compliant Calibration without Accreditation
AMG	17025 Compliant Calibration with Accreditation

## Software and Firmware Updates

From time to time Keysight Technologies releases software and firmware updates for its products. To search for firmware updates for your oscilloscope, direct your web browser to [www.keysight.com/find/HD3-Series-sw](http://www.keysight.com/find/HD3-Series-sw).

To view the currently installed software and firmware press **[Help] > About Oscilloscope**.

Once you have downloaded a firmware update file, you can place it on a USB storage device and load the file using File Explorer (see **"File Explorer"** on page 277), or you can use the Instrument Utilities page of the oscilloscope's web interface (see **"Instrument Utilities"** on page 301).

## Binary Data (.bin) Format

The binary data format stores waveform data in binary format and provides data headers that describe that data.

Because the data is in binary format, the size of the file is approximately 5 times smaller than the ASCII XY format.

If more than one source is on, all displayed sources will be saved, except math functions.

When using segmented memory, each segment is treated as a separate waveform. All segments for a channel are saved, then all segments of the next (higher numbered) channel are saved. This continues until all displayed channels are saved.

When the oscilloscope is in the Peak Detect acquisition mode, the minimum and maximum value waveform data points are saved to the file in separate waveform buffers. The minimum value data points are saved first; then, the maximum value data points are saved.

### BIN data - using segmented memory

When saving all segments, each segment has its own waveform header (see **"Binary Header Format"** on page 310).

In BIN file format, data are presented as follows:

- Channel 1 data (all segments)
- Channel 2 data (all segments)
- Channel 3 data (all segments)
- Channel 4 data (all segments)
- Digital channel data (all segments)
- Math waveform data (all segments)

When not saving all segments, the number of waveforms is equivalent to the number of active channels (including math and digital channels, with up to seven waveforms for each digital pod). When saving all segments, the number of waveforms is equal to the number of active channels multiplied by the number of segments acquired.

## Binary Data in MATLAB

Binary data from an InfiniiVision oscilloscope can be imported to The MathWorks MATLAB®. You can download the appropriate MATLAB functions from the Keysight Technologies web site at [www.keysight.com/find/HD3-Series-examples](http://www.keysight.com/find/HD3-Series-examples).

Keysight provides the .m files, which need to be copied into the work directory for MATLAB. The default work directory is C:\MATLAB7\work.

## Binary Header Format

**File Header** There is only one file header in a binary file. The file header consists of the following information.

Cookie	Two byte characters, AG, that indicate the file is in the Keysight Binary Data file format.
Version	Two bytes that represent the file version.
File Size	A 32-bit integer that is the number of bytes that are in the file.
Number of Waveforms	A 32-bit integer that is the number of waveforms that are stored in the file.

**Waveform Header** It is possible to store more than one waveform in the file, and each waveform stored will have a waveform header. When using segmented memory, each segment is treated as a separate waveform. The waveform header contains information about the type of waveform data that is stored following the waveform data header.

Header Size	A 32-bit integer that is the number of bytes in the header.
Waveform Type	A 32-bit integer that is the type of waveform stored in the file: <ul style="list-style-type: none"> <li>▪ 0 = Unknown.</li> <li>▪ 1 = Normal.</li> <li>▪ 2 = Peak Detect.</li> <li>▪ 3 = Average.</li> <li>▪ 4 = Not used in InfiniiVision oscilloscopes.</li> <li>▪ 5 = Not used in InfiniiVision oscilloscopes.</li> <li>▪ 6 = Logic.</li> </ul>
Number of Waveform Buffers	A 32-bit integer that is the number of waveform buffers required to read the data.
Points	A 32-bit integer that is the number of waveform points in the data.

Count	A 32-bit integer that is the number of hits at each time bucket in the waveform record when the waveform was created using an acquisition mode like averaging. For example, when averaging, a count of four would mean every waveform data point in the waveform record has been averaged at least four times. The default value is 0.
X Display Range	A 32-bit float that is the X-axis duration of the waveform that is displayed. For time domain waveforms, it is the duration of time across the display. If the value is zero then no data has been acquired.
X Display Origin	A 64-bit double that is the X-axis value at the left edge of the display. For time domain waveforms, it is the time at the start of the display. This value is treated as a double precision 64-bit floating point number. If the value is zero then no data has been acquired.
X Increment	A 64-bit double that is the duration between data points on the X axis. For time domain waveforms, this is the time between points. If the value is zero then no data has been acquired.
X Origin	A 64-bit double that is the X-axis value of the first data point in the data record. For time domain waveforms, it is the time of the first point. This value is treated as a double precision 64-bit floating point number. If the value is zero then no data has been acquired.
X Units	A 32-bit integer that identifies the unit of measure for X values in the acquired data: <ul style="list-style-type: none"> <li>▪ 0 = Unknown.</li> <li>▪ 1 = Volts.</li> <li>▪ 2 = Seconds.</li> <li>▪ 3 = Constant.</li> <li>▪ 4 = Amps.</li> <li>▪ 5 = dB.</li> <li>▪ 6 = Hz.</li> </ul>
Y Units	A 32-bit integer that identifies the unit of measure for Y values in the acquired data. The possible values are listed above under X Units.
Date	A 16-byte character array, left blank in InfiniiVision oscilloscopes.
Time	A 16-byte character array, left blank in the InfiniiVision oscilloscopes.
Frame	A 24 byte character array that is the model number and serial number of the oscilloscope in the format of: MODEL#:SERIAL#.
Waveform Label	A 16 byte character array that contains the label assigned to the waveform.
Time Tags	A 64-bit double, only used when saving multiple segments (requires segmented memory option). This is the time (in seconds) since the first trigger.
Segment Index	A 32-bit unsigned integer. This is the segment number. Only used when saving multiple segments.

**Waveform Data Header** A waveform may have more than one data set. Each waveform data set will have a waveform data header. The waveform data header consists of information about the waveform data set. This header is stored immediately before the data set.

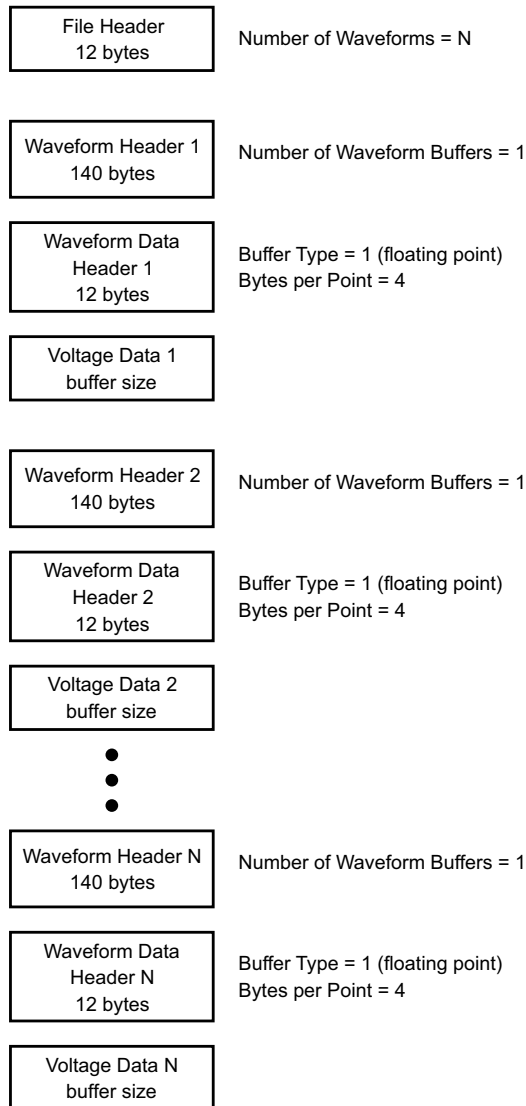
Waveform Data Header Size	A 32-bit integer that is the size of the waveform data header.
Buffer Type	A 16-bit short that is the type of waveform data stored in the file: <ul style="list-style-type: none"> <li>▪ 0 = Unknown data.</li> <li>▪ 1 = Normal 32-bit float data.</li> <li>▪ 2 = Maximum float data.</li> <li>▪ 3 = Minimum float data.</li> <li>▪ 4 = Not used in InfiniiVision oscilloscopes.</li> <li>▪ 5 = Not used in InfiniiVision oscilloscopes.</li> <li>▪ 6 = Digital unsigned 8-bit char data (for digital channels).</li> </ul>
Bytes Per Point	A 16-bit short that is the number of bytes per data point.
Buffer Size	A 32-bit integer that is the size of the buffer required to hold the data points.

### Example Program for Reading Binary Data

To find an example program for reading binary data, direct your web browser to [www.keysight.com/find/HD3-Series-examples](http://www.keysight.com/find/HD3-Series-examples), and select "Example Program for Reading Binary Data".

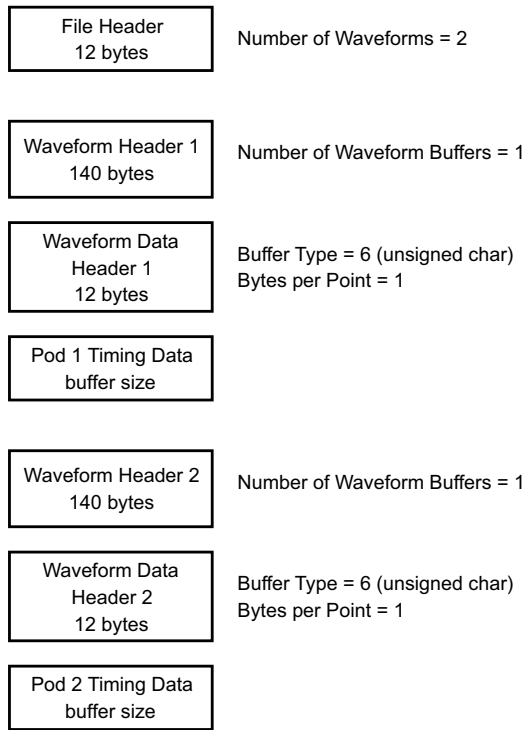
### Examples of Binary Files

**Single Acquisition Multiple Analog Channels** The following picture shows a binary file of a single acquisition with multiple analog channels.



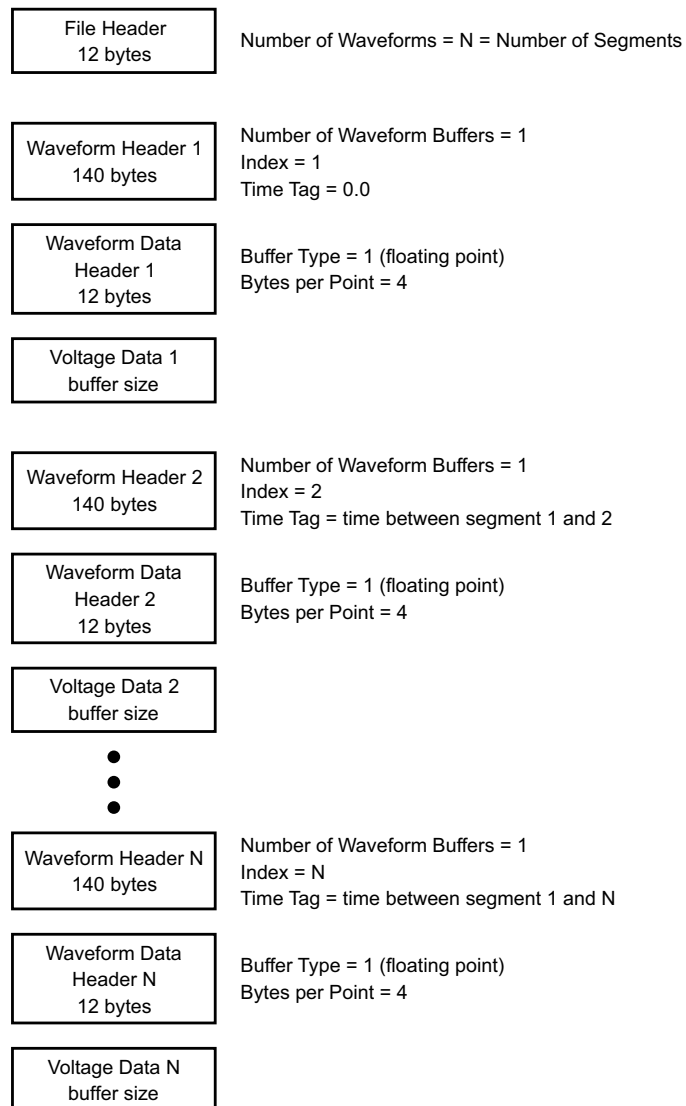
**Single Acquisition  
All Pods Logic  
Channels**

The following picture shows a binary file of a single acquisition with all pods for the logic channels saved.



**Segmented  
Memory  
Acquisition on One  
Analog Channel**

The following picture shows a binary file of a segmented memory acquisition on one analog channel.



## CSV and ASCII XY files

- ["CSV and ASCII XY file structure"](#) on page 315
- ["Minimum and Maximum Values in CSV Files"](#) on page 316
- ["Frequency Data in CSV Files"](#) on page 316

### CSV and ASCII XY file structure

In CSV or ASCII XY format the **Length** control selects the number of points per segment. All segments are contained in the CSV file or in each ASCII XY data file.

For example: If the Length control is set to 1000 points, there will be 1000 points (rows in the spreadsheet) per segment. When saving all segments there are three header rows, so the data for the first segment starts at row 4. The second segment's data starts at row 1004. The time column shows the time since the trigger on the first segment. The top row shows the selected number of points per segment.

BIN files are a more efficient data transfer format than CSV or ASCII XY. Use this file format for fastest data transfer.

## Minimum and Maximum Values in CSV Files

If you are running a Minimum or Maximum measurement, the minimum and maximum values shown in the measurement display may not appear in the CSV file.

**Explanation:** When the oscilloscope's sample rate is 4 GSa/s, a sample will be taken every 250 ps. If the horizontal scale is set to 10 us/div, there will be 100 us of data displayed (because there are ten divisions across the screen). To find the total number of samples the oscilloscope will take:

$$100 \text{ us} \times 4 \text{ GSa/s} = 400\text{K samples}$$

The oscilloscope is required to display those 400K samples using 640 pixel columns. The oscilloscope will decimate the 400K samples to 640 pixel columns, and this decimation keeps track of the min and max values of all the points that are represented by any given column. Those min and max values will be displayed in that screen column.

A similar process is used to reduce the acquired data to produce a record usable for various analysis needs such as measurements and CSV data. This *analysis record* is much larger than 640 and can contain 65536 or more points. Still, once the # of acquired points is greater than the analysis record length, some form of decimation is required. The decimator used to produce a CSV record is configured to provide a best-estimate of all the samples that each point in the record represents. Therefore, the min and max values may not appear in the CSV file.

## Frequency Data in CSV Files








When data for multiple frequency sources is saved to a CSV file, this data is saved as one set (with multiple columns) using a horizontal (X) range that covers all sources.

## Acknowledgements

Third-party software acknowledgements and licenses for these InfiniiVision HD3-Series oscilloscopes are located at [www.keysight.com/find/InfiniiVision-third-party-software](http://www.keysight.com/find/InfiniiVision-third-party-software).

## Product Markings and Regulatory Information

These symbols are used on the HD3-Series oscilloscopes.

Symbol	Description
	Caution, refer to accompanying documentation
	The crossed out wheeled bin symbol indicates that separate collection for waste electric and electronic equipment (WEEE) is required, as obligated by the EU DIRECTIVE and other National legislation. Please refer to <a href="https://www.keysight.com/go/takeback">keysight.com/go/takeback</a> to understand your Trade in options with Keysight in addition to product takeback instructions.
	Indicates the time period during which no hazardous or toxic substance elements are expected to leak or deteriorate during normal use. Forty years is the expected useful life of the product.
	The RCM mark is a registered trademark of the Australian Communications and Media Authority.
	The CE mark is a registered trademark of the European Community. ICES / NMB-001 Cet appareil ISM est conforme a la norme NMB du Canada. This is a marking to indicate product compliance with the Industry Canadian Interference-Causing Equipment Standard (ICES-001). This is also a symbol of an Industrial Scientific and Medical Group 1 Class A product (CISPR 11, Clause 4).
	The CSA mark is a registered trademark of the CSA International.
	This mark denotes compliance with the essential requirements of the following applicable UK regulations: <ul style="list-style-type: none"> <li>▪ Electromagnetic Compatibility Regulations 2016 No. 1091 (as amended)</li> <li>▪ Electrical Equipment (Safety) Regulations 2016 No. 1101 (as amended)</li> <li>▪ The Restriction of the Use of Certain Hazardous Substances in Electrical and Electronic Equipment Regulations 2012 No. 3032 (as amended)</li> </ul>

### Compliance with German Noise Requirements

This is to declare that this instrument is in conformance with the German Regulation on Noise Declaration for Machines (Laermangabe nach der Maschinenlaermrrordnung -3.GSGV Deutschland).

Acoustic Noise Emission/Geraeuschemission	
LpA <70 dB Operator position Normal position per ISO 7779	LpA <70 dB am Arbeitsplatz normaler Betrieb nach DIN 45635 t.19

# 25 CAN Triggering and Protocol Decode

CAN/CAN FD Protocol Decode Setup / 319

Loading and Displaying CAN Symbolic Data / 323

CAN/CAN FD Triggering / 324

Interpreting CAN/CAN FD Decode / 326

Interpreting CAN Lister Data / 328

Searching for CAN Data in the Lister / 328

CAN triggering and protocol decode option is included with the Automotive Serial Analysis license.

## CAN/CAN FD Protocol Decode Setup

To enable CAN/CAN FD protocol decode:

**1** Press [**Protocol Decode**].

Or:

**a** From the main menu, choose **Analyze > Protocol Decode...**

**b** In the Protocol Decode dialog box, select **Enable**.

**c** Select either the **P1** or **P2** tab (the oscilloscope can decode two protocols at the same time), and select **On**.

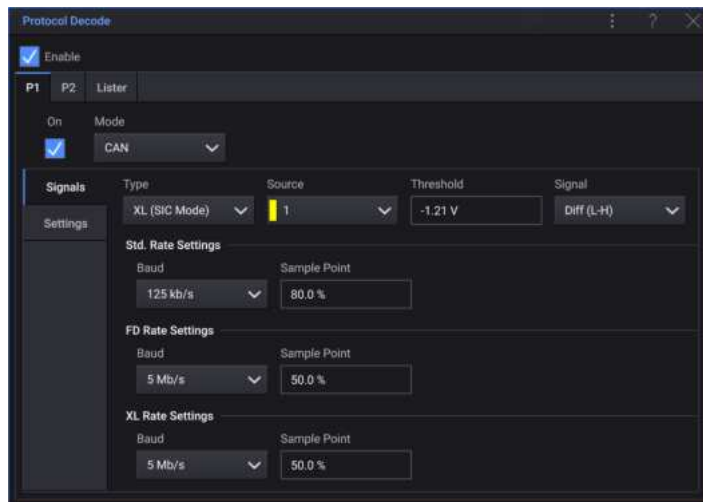
**2** From the **Mode** drop-down list, select **CAN**.

Below the **Mode** selection are vertical tabs for specifying **Signals** and **Settings**.

**Signals** Setup consists of connecting the oscilloscope to a CAN signal, using the Signals subtab controls to specify the signal source, threshold voltage level, baud rate, and sample point.

Connect the oscilloscope to a CAN signal that has a dominant-low polarity. If you are connecting to the CAN signal using a differential probe, connect the probe's positive lead to the dominant-low CAN signal and connect the negative lead to the dominant-high CAN signal.

The CAN protocol decode mode has these controls for setting up the signal:



- **Source** – Selects the channel for the CAN signal.  
The label for the CAN source channel is automatically set.
- **Threshold** – Specifies the CAN signal threshold voltage level.  
The threshold voltage level is used in decoding, and it will become the trigger level when the trigger type is set to the selected protocol decode bus.
- **Signal** – Selects the type and polarity of the CAN signal. This also automatically sets the channel label for the source channel.
  - **CAN\_H** – The actual CAN\_H differential bus.
  - **Differential (H-L)** – The CAN differential bus signals connected to an analog source channel using a differential probe. Connect the probe's positive lead to the dominant-high CAN signal (CAN\_H) and connect the negative lead to the dominant-low CAN signal (CAN\_L).

Dominant low signals:

- **Rx** – The Receive signal from the CAN bus transceiver.
- **Tx** – The Transmit signal from the CAN bus transceiver.
- **CAN\_L** – The actual CAN\_L differential bus signal.
- **Differential (L-H)** – The CAN differential bus signals connected to an analog source channel using a differential probe. Connect the probe's positive lead to the dominant-low CAN signal (CAN\_L) and connect the negative lead to the dominant-high CAN signal (CAN\_H).

- **Std. Rate Settings** – :

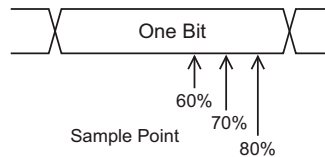
- **Baud** – Select the baud rate that matches match your CAN bus signal.

The CAN baud rate can be set to predefined baud rates from 10 kb/s up to 5 Mb/s or a user-defined baud rate from 10.0 kb/s to 4 Mb/s in increments of 100 b/s. Fractional user-defined baud rates between 4 Mb/s and 5 Mb/s are not allowed.

The default baud rate is 125 kb/s

If none of the pre-defined selections match your CAN bus signal, select **User Defined** and use the **User Baud** field to enter the baud rate.

- **Sample Point** – Select the point between phase segments 1 and 2 where the state of the bus is measured. This controls the point within the bit's time where the bit value is captured.



- **FD Rate Settings** – When decoding CAN FD:

**NOTE**

For standard CAN, only the Standard Rate Settings must be set correctly. For CAN FD, both the Standard Rate Settings and the FD Rate Settings must be set correctly.

- **Baud** – Select the CAN FD baud rate of the signal from your device under test.

If the desired baud rate is not shown in the list, select **User Defined** and use the **User Baud** field to enter the baud rate.

The CAN FD baud rate can be set to predefined baud rates from 1-10 Mb/s or a user-defined baud rate from 10.0 kb/s to 10 Mb/s in increments of 100 b/s.

If the baud rate you select does not match the CAN FD baud rate, false triggers and decoding may occur.

- **Sample Point** – Specify the sample point.

The sample point is the point during the bit time where the bit level is sampled to determine whether it is dominant or recessive. The sample point represents the percentage of time between the beginning of the bit time to the end of the bit time.

You may need to adjust the sample point to get a reliable trigger and decode, depending on your CAN FD network topology and where the oscilloscope probe is located in the network.

- **Standard** – Select the standard that will be used when decoding or triggering on FD frames, **ISO**, or **non-ISO**.

This setting has no effect on the processing of non-FD (classical) frames.

- **XL Rate Settings** – When decoding CAN XL:

#### NOTE

For CAN XL, the **Standard Rate Settings**, the **FD Rate Settings**, and the **XL Rate Settings** must be set correctly.

- **Baud** – Select the CAN XL baud rate of the signal from your device under test.

If the desired baud rate is not shown in the list, select **User Defined** and use the **User Baud** field to enter the baud rate.

The CAN XL baud rate can be set to predefined baud rates from 1–10 Mb/s or a user-defined baud rate from 10.0 kb/s to 10 Mb/s in increments of 100 b/s.

If the baud rate you select does not match the CAN XL baud rate, false triggers and decoding may occur.

- **Sample Point** – Specify the sample point.

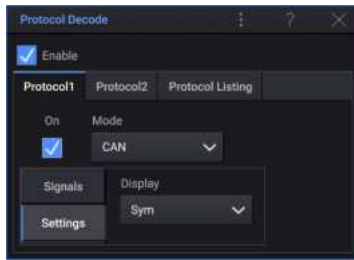
The sample point is the point during the bit time where the bit level is sampled to determine whether it is dominant or recessive. The sample point represents the percentage of time between the beginning of the bit time to the end of the bit time.

You may need to adjust the sample point to get a reliable trigger and decode, depending on your CAN XL network topology and where the oscilloscope probe is located in the network.

- **Standard** – Select the standard that will be used when decoding or triggering on FD frames, **ISO**, or **non-ISO**.

This setting has no effect on the processing of CAN and CAN FD frames.

**Settings** The CAN protocol decode mode has these controls for decode settings:



- **Display** – When CAN symbolic information is loaded, you can select between **Hex** and **Symbolic** display of the decoded data.
- Notes**
- The CAN triggering and serial decode option is license-enabled.
  - If the decode line does not appear on the display, press the **[Protocol Decode]** key to turn it on.
  - If the oscilloscope is stopped, press the **[Run/Stop]** key to acquire and decode data.
  - If the setup does not produce a stable trigger, the CAN signal may be slow enough that the oscilloscope is Auto triggering. Press the **[Mode]** key to set the trigger mode from **Auto** to **Trig'd**.
  - You can use the horizontal **[Zoom]** window for easier navigation of the decoded data.
- See Also**
- **"Loading and Displaying CAN Symbolic Data"** on page 323
  - **"CAN/CAN FD Triggering"** on page 324
  - **"Interpreting CAN/CAN FD Decode"** on page 326
  - **"Interpreting CAN Lister Data"** on page 328
  - **"Searching for CAN Data in the Lister"** on page 328

## Loading and Displaying CAN Symbolic Data

When you load (recall) a CAN DBC communication database (\*.dbc) file into the oscilloscope, its symbolic information can be:

- Displayed in the decode waveform and Lister window.
- Used when setting up CAN triggering.
- Used when searching for CAN data in the decode.

To recall a DBC file into the oscilloscope:

- 1 From the main menu, choose **File > Open...**
- 2 In the Open dialog box, from the **Format** drop-down menu, select **CAN Symbolic data (\*.dbc)**.

- 3 From the **Load to:** drop-down list, select which protocol decode (**P1** or **P2**) the symbolic information will be used with.
- 4 Use the controls in the bottom of the dialog box to select the file to be recalled.
- 5 Select **Open**.

A message indicating whether the open was successful is displayed.

The DBC file remains in the oscilloscope until it is overwritten or a secure erase is performed.

To display CAN symbolic data:

- 1 Press [**Protocol Decode**].
- 2 In the **Settings** controls, from the **Display** drop-down list, select **Symbolic** (instead of **Hexadecimal**).

Your choice affects both the decode waveform and the Lister window.

#### NOTE

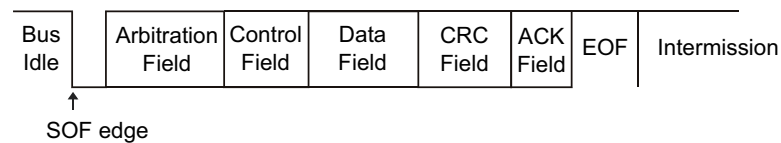
For CAN FD frames, symbolic decoding is limited to the first eight bytes.

## CAN/CAN FD Triggering

To set up the oscilloscope to capture a CAN signal, see "[CAN/CAN FD Protocol Decode Setup](#)" on page 319.

The Controller Area Network (CAN) trigger allows triggering on CAN version 2.0A, 2.0B, and CAN FD (Flexible Data-rate) signals.

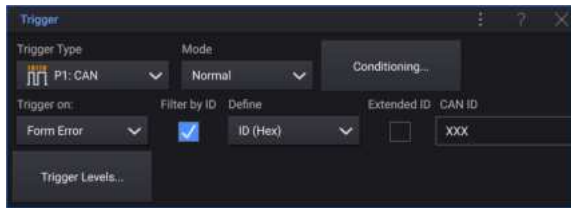
A CAN message frame in CAN\_L signal type is shown below:



After setting up the oscilloscope to capture a CAN signal:

- 1 Select the trigger badge, or from the main menu, choose **Trigger > Setup...**
- 2 In the Trigger dialog box, from the **Trigger Type** drop-down list, select **Protocol 1: CAN** or **Protocol 2: CAN**.

The Trigger dialog box controls unique to the **PN: CAN** trigger type are:



- **Trigger on:** – Selects the trigger condition:
  - **SOF - Start of Frame** – Triggers at the start bit for both data and overload frames.
  - **EOF - End of Frame** – Triggers at the end of any frame. \*
  - **Frame ID** – Triggers on any standard CAN (data or remote) or CAN FD frame at the end of the 11- or 29-bit ID field.
  - **Data Frame ID (non-FD)** – Triggers on standard CAN data frames at the end of the 11- or 29-bit ID field.
  - **Data Frame ID and Data (non-FD)** – Triggers on any standard CAN data frame at the end of the last data byte defined in the trigger. The DLC of the packet must match the number of bytes specified.
  - **Data Frame ID and Data (FD)** – Triggers on CAN FD frames at the end of the last data byte defined in the trigger. You can trigger on up to 8 bytes of data anywhere within the CAN FD data, which can be up to 64 bytes long.
  - **Remote Frame ID** – Triggers on standard CAN remote frames at the end of the 11- or 29-bit ID field.
  - **Error Frame** – Triggers after 6 consecutive 0s while in a data frame, at the EOF. \*
  - **Acknowledge Error** – Triggers on the acknowledge bit if the polarity is incorrect. \*
  - **Form Error** – Triggers on reserved bit errors. \*
  - **Stuff Error** – Triggers on 6 consecutive 1s or 6 consecutive 0s, while in a non-error or non overload frame. \*
  - **CRC Field Error** – Triggers when the calculated CRC does not match the transmitted CRC. In addition, for FD frames, will also trigger if the Stuff Count is in error. \*
  - **Spec Error (Ack or Form or Stuff or CRC)** – Triggers on Ack, Form, Stuff, or CRC errors. \*
  - **All Errors** – Triggers on all Spec errors and error frames. \*
  - **BRS Bit (FD)** – Triggers on the BRS bit of CAN FD frames. \*
  - **CRC Delimiter Bit (FD)** – Triggers on the CRC delimiter bit in CAN FD frames. \*
  - **ESI Bit Active (FD)** – Triggers on the ESI bit if set active. \*
  - **ESI Bit Passive (FD)** – Triggers on the ESI bit if set passive. \*

- **Overload Frame** – Triggers on an overload frame.

\* You can optionally qualify the trigger for frames whose ID you specify.

If you select a condition that lets you qualify by ID or trigger on ID or data values, select the **Filter by ID** check box and use the **Define, Extended ID**, and **CAN ID** controls to specify the ID values.

When CAN symbolic data is loaded into the oscilloscope (see "**Loading and Displaying CAN Symbolic Data**" on page 323), you can trigger on:

- **Message** – A symbolic message.
- **Message and Signal (non-FD)** – A symbolic message and a signal value.
- **Message and Signal (FD, first 8 bytes only)** – A symbolic message and a signal value, limited to the first 8 bytes of FD data.

Symbolic messages, signals, and values are defined in the DBC communication database file.

A message is the symbolic name for a CAN frame ID, a signal is the symbolic name for a bit or set of bits within the CAN data, and a value can be a symbolic representation of the signal bit values or it can be a decimal number with units.

## Interpreting CAN/CAN FD Decode



The CAN decode display is color coded as follows:

- Blue angled waveforms show an active bus (inside a packet/frame).

- Blue mid-level lines show an idle bus.
- Frame ID – yellow.
- Data bytes – white hex digits.
- CAN frame type and Data Length Code (DLC) – blue for data frames, green for remote frames. The DLC is always a decimal value. CAN frame types can be:
  - FD – a CAN FD frame whose bit rate does not switch during the data phase.
  - BRS – a CAN FD frame whose bit rate switches during the data phase.
  - RMT – a standard CAN remote frame.
  - Data – a standard CAN data frame.

The status of the Error State Indicator (ESI) flag is shown in the "Type" column of the Lister. If the ESI bit is recessive, indicating error passive, the background of the "Type" column will be yellow. If the ESI bit indicates error active, the "Type" column's background will be unshaded.

The DLC field will always be displayed in decimal, and will indicate the number of bytes in the frame. So for example, for an FD frame that has the DLC code 0xF, which represents a packet with 64 bytes, "DLC=64" will be displayed on the decode line, and "64" will be displayed in the DLC column of the Lister.

- Overload frame – blue with the text "OVRLD". An overload condition may occur before an end of frame condition. If so, the frame is closed and opened with blue brackets at the start of the overload condition.
- Stuff Count – green hex digit when valid, red when error detected. The hex digit shows the gray-coded with parity bit stuff count.
- CRC – blue hex digits when valid, red when error detected.
- Red angled waveforms – Unknown or error condition.
- Flagged error frames – red with "ERR FRAME", "STUFF ERR", "FORM ERR", "ACK ERR", "GLITCH ERR", or "?" (unknown).
- Pink vertical bars – Expand horizontal scale (and run again) to see decode.
- Red Dot – More information is available. Decoded text is truncated to fit. Expand the horizontal scale to view the information.

## Interpreting CAN Lister Data



In addition to the standard Time column, the CAN Lister contains these columns:

- ID – frame ID. Can be displayed as hex digits or symbolic information (see "[Loading and Displaying CAN Symbolic Data](#)" on page 323).
- Type – frame type (RMT remote frame or Data).
- DLC – data length code.
- Data – data bytes. Can be displayed as hex digits or symbolic information.
- CRC – cyclic redundancy check.
- Errors – highlighted in red. Errors can be Acknowledge (Ack, A), Form (Fo), or Frame (Fr). Different kinds of errors can be combined like "Fo,Fr" in the above example.

Aliased data is highlighted in pink. When this happens, decrease the horizontal time/div setting and run again.

## Searching for CAN Data in the Lister

The oscilloscope's search capability lets you search for (and mark) certain types of CAN data in the Lister (see "[Searching Lister Data](#)" on page 121). Then, you can use the navigation controls to navigate through the marked rows (see "[Navigating the Time Base](#)" on page 52).

The Search dialog box controls unique to the **PN: CAN** search type selection are:

- **Search for** – Selects the decode value to find:
  - **Frame ID** – Finds remote or data frames matching the specified ID.
  - **Data Frame ID** – Finds data frames matching the specified ID.
  - **Data Frame ID and Data** – Finds data frames matching the specified ID and data.
  - **Remote Frame ID** – Finds remote frames with the specified ID.
  - **Error Frame** – Finds CAN active error frames.
  - **Acknowledge Error** – Finds the acknowledge bit if the polarity is incorrect.
  - **Form Error** – Finds reserved bit errors.
  - **Stuff Error** – Finds 6 consecutive 1s or 6 consecutive 0s, while in a non-error or non overload frame.
  - **CRC Field Error** – Finds when the calculated CRC does not match the transmitted CRC.
  - **All Errors** – Finds any form error or active error.
  - **Overload Frame** – Finds CAN overload frames.

When CAN symbolic data is loaded into the oscilloscope (see "**Loading and Displaying CAN Symbolic Data**" on page 323), you can search for:

- **Message** – A symbolic message.
- **Message and Signal** – A symbolic message and a signal value.



# 26 I2C Triggering and Protocol Decode

- I2C Protocol Decode Setup / 331
- I2C Triggering / 333
- Interpreting I2C Decode / 336
- Interpreting I2C Lister Data / 337
- Searching for I2C Data in the Lister / 337

I2C triggering and protocol decode is included with the Embedded Serial Analysis license.

## I2C Protocol Decode Setup

To enable I<sup>2</sup>C protocol decode:

**1** Press [**Protocol Decode**].

Or:

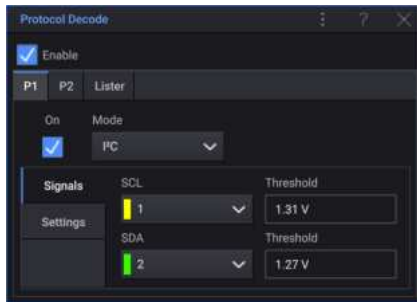
- a** From the main menu, choose **Analyze > Protocol Decode...**
- b** In the Protocol Decode dialog box, select **Enable**.
- c** Select either the **P1** or **P2** tab (the oscilloscope can decode two protocols at the same time), and select **On**.

**2** From the **Mode** drop-down list, select **I2C**.

Below the **Mode** selection are vertical tabs for specifying **Signals** and **Settings**.

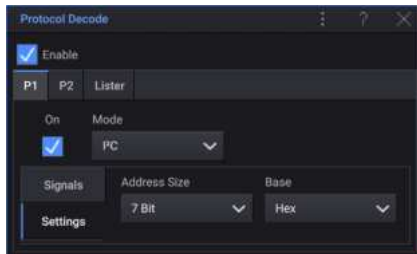
**Signals** I<sup>2</sup>C (Inter-IC bus) signals setup consists of connecting the oscilloscope to the serial data (SDA) line and the serial clock (SCL) line and then specifying the input signal threshold voltage levels.

The I2C protocol decode mode Signals subtab has these controls for setting up the signal:



- **SCL, SDA** – Select the channel for the signal.  
The SCL and SDA labels for the source channels are automatically set.
- **Threshold** – Select the signal threshold voltage level.  
The threshold voltage level is used in decoding, and it will become the trigger level when the trigger type is set to the selected serial decode slot.  
Data must be stable during the whole high clock cycle or it will be interpreted as a start or stop condition (data transitioning while the clock is high).

**Settings** The I2C protocol decode mode Settings subtab has these controls for decode settings:



- **Address Size** – Choose **7 Bit** or **8 Bit** address size.  
Use 8-bit address size to include the R/W bit as part of the address value, or choose 7-bit address size to exclude the R/W bit from the address value.
  - **Base** – Selects between **Hex** or **Binary** data value display.
- Notes**
- I2C triggering and serial decode is included with the Embedded Serial Analysis license.
  - If the decode line does not appear on the display, press the **[Protocol Decode]** key to turn it on.
  - If the oscilloscope is stopped, press the **[Run/Stop]** key to acquire and decode data.
  - If the setup does not produce a stable trigger, the I2C signals may be slow enough that the oscilloscope is Auto triggering. Press the **[Mode]** key to set the trigger mode from **Auto** to **Trig'd**.

- You can use the horizontal **[Zoom]** window for easier navigation of the decoded data.

- See Also
- **"I2C Triggering"** on page 333
  - **"Interpreting I2C Decode"** on page 336
  - **"Interpreting I2C Lister Data"** on page 337
  - **"Searching for I2C Data in the Lister"** on page 337

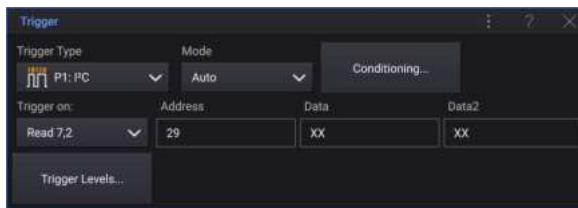
## I2C Triggering

To set up the oscilloscope to capture I2C signals, see **"I2C Protocol Decode Setup"** on page 331.

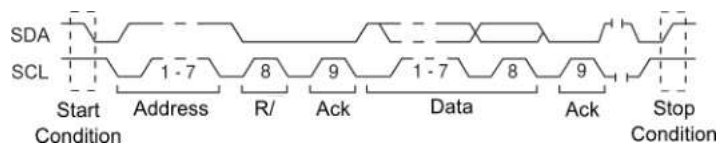
After the oscilloscope has been set up to capture I2C signals, you can trigger on a stop/start condition, a restart, a missing acknowledge, an EEPROM data read, or on a read/write frame with a specific device address and data value.

- 1 Select the trigger badge, or from the main menu, choose **Trigger > Setup....**
- 2 In the Trigger dialog box, from the **Trigger Type** drop-down list, select **Protocol 1: I2C** or **Protocol 2: I2C**.

The Trigger dialog box controls unique to the **PN: I2C** trigger type are:

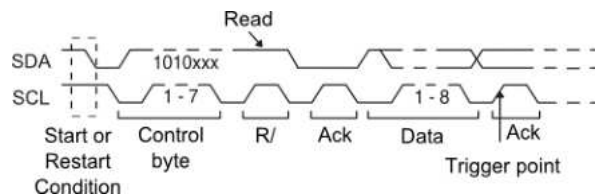


- **Trigger on:** – Selects the trigger condition:
  - **Start Condition** – Triggers when SDA data transitions from high to low while the SCL clock is high. For triggering purposes (including frame triggers), a restart is treated as a start condition.
  - **Stop Condition** – Triggers when data (SDA) transitions from low to high while the clock (SCL) is high.

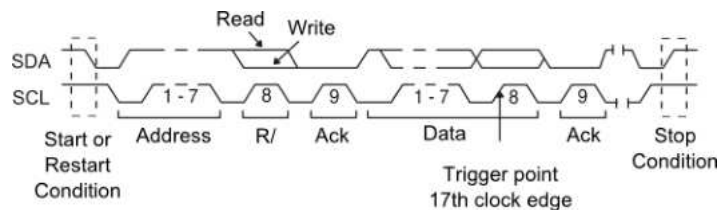


- **Restart** – Triggers when another start condition occurs before a stop condition.

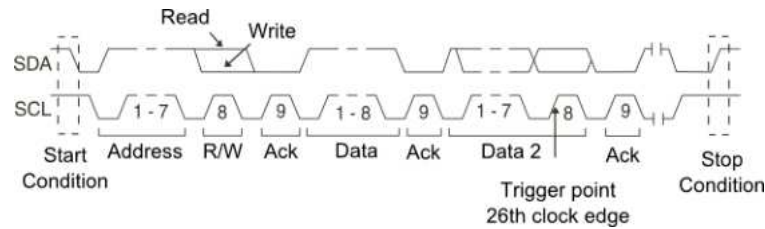
- **Address** – triggers on the selected address. The R/W bit is ignored.
- **Address with no Ack** – The oscilloscope triggers when the acknowledge of the selected address field is false. The R/W bit is ignored.
- **Write Data with no Ack** – Triggers if a write data byte is not acknowledged. Note that this trigger mode will not trigger if the ack following the R/W bit is missing, but will only trigger on missing acks following data bytes.
- **Missing Acknowledge** – Triggers when SDA data is high during any Ack SCL clock bit.
- **EEPROM Data Read** – The trigger looks for EEPROM control byte value 1010xxx on the SDA line, followed by a Read bit and an Ack bit. It then looks for the data value and qualifier set by the **Data is** and **Data** controls. When this event occurs, the oscilloscope will trigger on the clock edge for the Ack bit after the data byte. This data byte does not need to occur directly after the control byte. The oscilloscope will trigger on any data byte that meets the criteria defined by the **Data is** and **Data** controls during a current address read or a random read or a sequential read cycle.



- **Data is** – Set the oscilloscope to trigger when data is = (**equal to**), ≠ (**not equal to**), < (**less than**), or > (**greater than**) the data value set in the **Data** field.
- **Frame (Start: Addr7: Read: Ack: Data)** or **Frame (Start: Addr7: Write: Ack: Data)** – The oscilloscope triggers on a read or write frame in 7-bit addressing mode on the 17th clock edge if all bits in the pattern match. For triggering purposes, a restart is treated as a start condition.



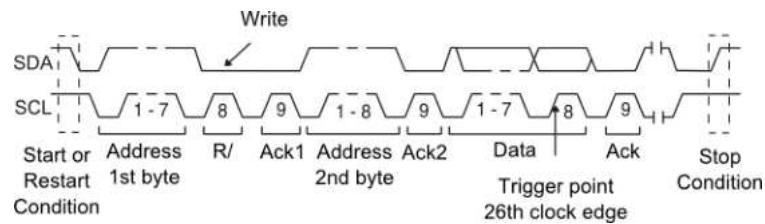
- **Frame (Start: Addr7: Read: Ack: Data: Ack: Data2)** or **Frame (Start: Addr7: Write: Ack: Data: Ack: Data2)** – The oscilloscope triggers on a read or write frame in 7-bit addressing mode on the 26th clock edge if all bits in the pattern match. For triggering purposes, a restart is treated as a start condition.



- **10-bit Write** – The oscilloscope triggers on a 10-bit write frame on the 26th clock edge if all bits in the pattern match. The frame is in the format:

Frame (Start: Address byte 1: Write: Address byte 2: Ack: Data)

For triggering purposes, a restart is treated as a start condition.



If you have set the oscilloscope to trigger on a 7-bit address read or write frame condition or a 10-bit write frame condition:

- **Address** – Select the 7-bit or 10-bit device address.

You can select from an address range of 0x00 to 0x7F (7-bit) or 0x3FF (10-bit) hexadecimal. When triggering on a read/write frame, the oscilloscope will trigger after the start, address, read/write, acknowledge, and data events occur.

If don't care is selected (0xFF or 0xFFFF) for the address, the address will be ignored. The trigger will always occur on the 17th clock for 7-bit addressing or 26th clock for 10-bit addressing.

- **Data** – Enter the 8-bit data pattern on which to trigger.

You can select a data value in the range of 0x00 to 0xFF (hexadecimal). The oscilloscope will trigger after the start, address, read/write, acknowledge, and data events occur.

If don't care (0xFF) is selected for data, the data will be ignored. The trigger will always occur on the 17th clock for 7-bit addressing or 26th clock for 10-bit addressing.

- **Data2** – If you have selected a three-byte trigger, enter the 8-bit data pattern on which to trigger.

## Interpreting I2C Decode



- Angled waveforms show an active bus (inside a packet/frame).
- Mid-level blue lines show an idle bus.
- In the decoded hexadecimal data:
  - Address values appear at the start of a frame.
  - Write addresses appear in light-blue along with the "W" character.
  - Read addresses appear in yellow along with the "R" character.
  - Restart addresses appear in green along with the "S" character.
  - Data values appear in white.
  - "a" indicates Ack (low), "~a" indicates No Ack (high).
  - Decoded text is truncated at the end of the associated frame when there is insufficient space within frame boundaries.
- Pink vertical bars indicate you need to expand the horizontal scale (and run again) to see decode.
- Red dots in the decode line indicate that more data can be displayed. Scroll or expand the horizontal scale to view the data.
- Aliased bus values (undersampled or indeterminate) are drawn in pink.
- Unknown bus values (undefined or error conditions) are drawn in red.

## Interpreting I2C Lister Data



In addition to the standard Time column, the I2C Lister contains these columns:

- Restart – indicated with an "X".
- Address – colored blue for writes, yellow for reads.
- Data – data bytes.
- Missing Ack – indicated by an "X", highlighted in red if an error.

Aliased data is highlighted in pink. When this happens, decrease the horizontal time/div setting and run again.

## Searching for I2C Data in the Lister

The oscilloscope's search capability lets you search for (and mark) certain types of I2C data in the Lister (see ["Searching Lister Data"](#) on page 121). Then, you can use the navigation controls to navigate through the marked rows (see ["Navigating the Time Base"](#) on page 52).

The Search dialog box controls unique to the **PN: I2C** search type selection are:

- **Search for** – Selects the decode value to find:
  - **Restart** – Finds when another start condition occurs before a stop condition.
  - **Address** – Finds a packet with the specified address, ignoring the R/W bit.

- **Address with no Ack** – Finds when the acknowledge of the selected address field is false. The R/W bit is ignored.
- **Missing Acknowledge** – Finds SDA data is high during any Ack SCL clock bit.
- **EEPROM Data Read** – Finds EEPROM control byte value 1010xxx on the SDA line, followed by a Read bit and an Ack bit. It then looks for the data value and qualifier set by the **Data is** and the **Data** controls.
- **Frame(Start:Address7:Read:Ack:Data)** – Finds a read frame on the 17th clock edge if all bits in the pattern match.
- **Frame(Start:Address7:Write:Ack:Data)** – Finds a write frame on the 17th clock edge if all bits in the pattern match.
- **Frame(Start:Address7:Read:Ack:Data:Ack:Data2)** – Finds a read frame on the 26th clock edge if all bits in the pattern match.
- **Frame(Start:Address7:Write:Ack:Data:Ack:Data2)** – Finds a write frame on the 26th clock edge if all bits in the pattern match.

# 27 LIN Triggering and Protocol Decode

- LIN Protocol Decode Setup / 339
- Loading and Displaying LIN Symbolic Data / 342
- LIN Triggering / 342
- Interpreting LIN Decode / 344
- Interpreting LIN Lister Data / 345
- Searching for LIN Data in the Lister / 345

LIN triggering and protocol decode option is included with the Automotive Serial Analysis license.

## LIN Protocol Decode Setup

To enable LIN protocol decode:

**1** Press [**Protocol Decode**].

Or:

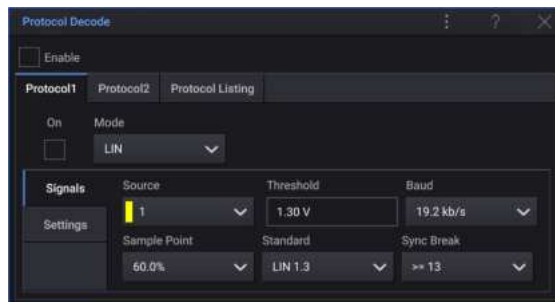
- a** From the main menu, choose **Analyze > Protocol Decode...**
- b** In the Protocol Decode dialog box, select **Enable**.
- c** Select either the **P1** or **P2** tab (the oscilloscope can decode two protocols at the same time), and select **On**.

**2** From the **Mode** drop-down list, select **LIN**.

Below the **Mode** selection are vertical tabs for specifying **Signals** and **Settings**.

**Signals** LIN (Local Interconnect Network) signal setup consists of connecting the oscilloscope to a serial LIN signal, specifying the signal source, threshold voltage level, baud rate, sample point, and other LIN signal parameters.

The LIN protocol decode mode Signals subtab has these controls for setting up the signal:

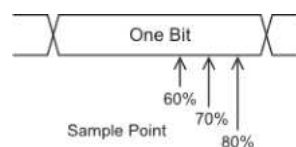


- **Source** – Selects the channel for the LIN signal.  
The label for the LIN source channel is automatically set.
- **Threshold** – Specifies the LIN signal threshold voltage level to the middle of the LIN signal.  
The threshold voltage level is used in decoding, and it will become the trigger level when the trigger type is set to the selected protocol decode bus.
- **Baud** – Select the baud rate that matches match your LIN bus signal.  
The default baud rate is 19.2 kb/s.

If none of the pre-defined selections match your CAN bus signal, select **User Defined** and use the **User Baud** field to enter the baud rate.

You can set the LIN baud rate from 2.4 kb/s to 625 kb/s in increments of 100 b/s.

- **Sample Point** – Select the sample point at which the oscilloscope will sample the bit value.

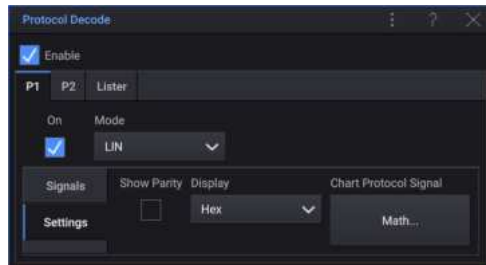


- **Standard** – Select the LIN standard you are measuring:
  - **LIN 1.3**
  - **LIN 1.3 (no length control)** – Select this for systems where length control is not used and all nodes have knowledge of the data packet size. In LIN 1.3, the ID may or may not be used to indicate the number of bytes. (In LIN 2.X, there is no length control.)
  - **LIN 2.X**

For LIN 1.2 signals, use the LIN 1.3 setting. The LIN 1.3 setting assumes the signal follows the "Table of Valid ID Values" as shown in section A.2 of the LIN Specification dated December 12, 2002. If your signal does not comply with the table, use the LIN 2.X setting.

- **Sync Break** – Select the minimum number of clocks that define a sync break in your LIN signal.

**Settings** The LIN protocol decode mode Settings subtab has these controls for decode settings:



- **Show Parity** – Choose whether to include the parity bits in the identifier field.
  - a If you want to mask the upper two parity bits, ensure that the **Show Parity** check box is not selected.
  - b If you want to include the parity bits in the identifier field, ensure that the **Show Parity** check box is selected.
- **Display** – When LIN symbolic information is loaded, you can select between **Hex** and **Symbolic** display of the decoded data.

- Notes**
- The LIN triggering and serial decode option is license-enabled.
  - If the decode line does not appear on the display, press the **[Protocol Decode]** key to turn it on.
  - If the oscilloscope is stopped, press the **[Run/Stop]** key to acquire and decode data.
  - If the setup does not produce a stable trigger, the LIN signal may be slow enough that the oscilloscope is Auto triggering. Press the **[Mode]** key to set the trigger mode from **Auto** to **Trig'd**.
  - You can use the horizontal **[Zoom]** window for easier navigation of the decoded data.

- See Also**
- ["Loading and Displaying LIN Symbolic Data"](#) on page 342
  - ["LIN Triggering"](#) on page 342
  - ["Interpreting LIN Decode"](#) on page 344
  - ["Interpreting LIN Lister Data"](#) on page 345
  - ["Searching for LIN Data in the Lister"](#) on page 345

## Loading and Displaying LIN Symbolic Data

When you load (recall) a LIN description file (\*.ldf) into the oscilloscope, its symbolic information can be:

- Displayed in the decode waveform and Lister window.
- Used when setting up LIN triggering.
- Used when searching for LIN data in the decode.

To recall a LIN description file into the oscilloscope:

- 1 From the main menu, choose **File > Open...**
- 2 In the Open dialog box, from the **Format** drop-down menu, select **LIN Symbolic data (\*.ldf)**.
- 3 From the **Load to:** drop-down list, select which protocol decode (**P1** or **P2**) the symbolic information will be used with.
- 4 Use the controls in the bottom of the dialog box to select the file to be recalled.
- 5 Select **Open**.

A message indicating whether the open was successful is displayed.

The LIN description file remains in the oscilloscope until it is overwritten or a secure erase is performed.

To display LIN symbolic data:

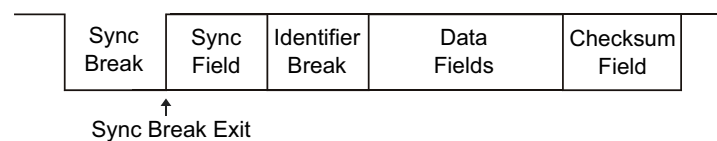
- 1 Press **[Protocol Decode]**.
- 2 In the **Settings** controls, from the **Display** drop-down list, select **Symbolic** (instead of **Hexadecimal**).

Your choice affects both the decode waveform and the Lister window.

## LIN Triggering

To set up the oscilloscope to capture a LIN signal, see "[LIN Protocol Decode Setup](#)" on page 339.

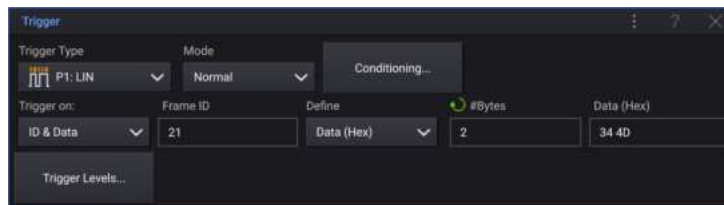
A LIN signal message frame is shown below:



LIN triggering can trigger on the rising edge at the Sync Break exit of the LIN single-wire bus signal (that marks the beginning of the message frame), the Frame ID, or the Frame ID and Data.

- 1 Select the trigger badge, or from the main menu, choose **Trigger > Setup...**
- 2 In the Trigger dialog box, from the **Trigger Type** drop-down list, select **Protocol 1: LIN** or **Protocol 2: LIN**.

The Trigger dialog box controls unique to the **PN: LIN** trigger type are:



- **Trigger on:** – Selects the trigger condition:
  - **Sync** (Sync Break) – The oscilloscope triggers on the rising edge at the Sync Break exit of the LIN single-wire bus signal that marks the beginning the message frame.
  - **ID** (Frame ID) – The oscilloscope triggers when a frame with an ID equal to the selected value is detected. Enter the value in the **Frame ID** field.
  - **ID & Data** (Frame ID and Data) – The oscilloscope triggers when a frame with an ID and data equal to the selected values is detected. When triggering on a frame ID and data:
    - Enter the frame ID value in the **Frame ID** field.
    - Note that you can enter a "don't care" value for the frame ID and trigger on data values only.
    - To set up the number of data bytes and enter their values (in hexadecimal or binary), use the remaining fields.
  - **Parity Error** – The oscilloscope triggers on parity errors.
  - **Checksum Error** – The oscilloscope triggers on checksum errors.

When a LIN description file (\*.ldf) is loaded (recalled) into the oscilloscope (see "[Loading and Displaying LIN Symbolic Data](#)" on page 342), you can trigger on:

- **Frame (Symbolic)** – A symbolic frame value.
- **Frame and Signal** – A symbolic frame value and a signal value.

Symbolic frames, signals, and values are defined in the LIN description file.

A frame is the symbolic name for a LIN frame ID, a signal is the symbolic name for a bit or set of bits within the LIN data, and a value can be a symbolic representation of the signal bit values or it can be a decimal number with units.

## Interpreting LIN Decode



- Angled waveforms show an active bus (inside a packet/frame).
- Mid-level blue lines show an idle bus.
- The hexadecimal ID and parity bits (if enabled) appear in yellow. If a parity error is detected the hexadecimal ID and parity bits (if enabled) appear in red.
- Decoded hexadecimal data values appear in white.
- The checksum appears in blue if correct, or red if incorrect.
- Decoded text is truncated at the end of the associated frame when there is insufficient space within frame boundaries.
- Pink vertical bars indicate you need to expand the horizontal scale (and run again) to see decode.
- Red dots in the decode line indicate that there is data that is not being displayed. Scroll or expand the horizontal scale to view the information.
- Unknown bus values (undefined or error conditions) are drawn in red.
- If there is an error in the synch field, SYNC will appear in red.
- If the header exceeds the length specified in the standard, THM will appear red.
- If the total frame count exceeds the length specified in the standard, TFM will appear red (LIN 1.3 only).
- For LIN 1.3 a wakeup signal is indicated by WAKE in blue. If the wakeup signal is not followed by a valid wakeup delimiter a wakeup error is detected and displayed as WUP in red.

## Interpreting LIN Lister Data



In addition to the standard Time column, the LIN Lister contains these columns:

- ID – frame ID. Can be displayed as hex digits or symbolic information (see "[Loading and Displaying LIN Symbolic Data](#)" on page 342).
- Data – data bytes. Can be displayed as hex digits or symbolic information.
- Checksum.
- Errors – highlighted in red.

Aliased data is highlighted in pink. When this happens, decrease the horizontal time/div setting and run again.

## Searching for LIN Data in the Lister

The oscilloscope's search capability lets you search for (and mark) certain types of LIN data in the Lister (see "[Searching Lister Data](#)" on page 121). Then, you can use the navigation controls to navigate through the marked rows (see "[Navigating the Time Base](#)" on page 52).

The Search dialog box controls unique to the **PN: LIN** search type selection are:

- **Search for** – Selects the decode value to find:
  - **ID** – Finds frames with the specified ID. Enter the ID in the **Frame ID** field.

- **ID & Data** – Finds frames with the specified ID and data. Enter the ID in the **Frame ID** field. Enter the number of data bytes in the **#Bytes** field and the byte values in the **Data** field.
- **Errors** – Finds all errors.

# 28 SPI Triggering and Protocol Decode

SPI Protocol Setup / 347

SPI Triggering / 350

Interpreting SPI Decode / 351

Interpreting SPI Lister Data / 352

Searching for SPI Data in the Lister / 352

SPI triggering and protocol decode is included with the Embedded Serial Analysis license.

## NOTE

Only one SPI serial bus can be decoded at a time.

---

## SPI Protocol Setup

To enable SPI protocol decode:

**1** Press [**Protocol Decode**].

Or:

**a** From the main menu, choose **Analyze > Protocol Decode...**

**b** In the Protocol Decode dialog box, select **Enable**.

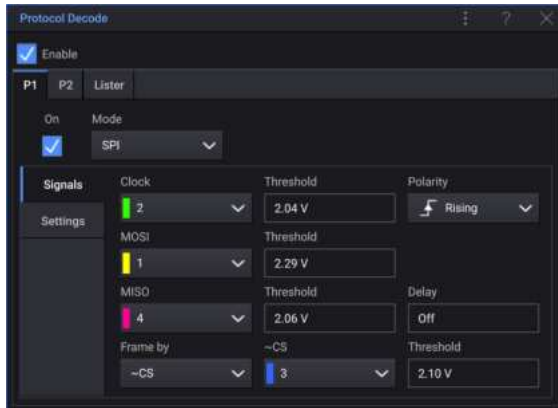
**c** Select either the **P1** or **P2** tab (the oscilloscope can decode two protocols at the same time), and select **On**.

**2** From the **Mode** drop-down list, select **SPI**.

Below the **Mode** selection are vertical tabs for specifying **Signals** and **Settings**.

**Signals** Serial Peripheral Interface (SPI) signals setup consists of: connecting the oscilloscope to a clock, MOSI data, MISO data, and framing signal, then setting the threshold voltage level for each input channel, and finally specifying any other signal parameters.

The SPI protocol decode mode Signals subtab has these controls for setting up the signals:



- **Clock, Threshold, Polarity** – For the SPI clock signal:
  - Select the channel connected to the SPI serial clock line.  
The CLK label for the source channel is automatically set.
  - Enter the clock signal threshold voltage level.  
The threshold voltage level is used in decoding, and it will become the trigger level when the trigger type is set to the selected serial decode slot.
  - Select the **Rising** or **Falling** edge for the selected Clock source.  
This determines which clock edge the oscilloscope will use to latch the serial data.
- **MOSI, Threshold** – For the SPI Master-Out Slave-In signal:
  - Select the channel that is connected to a SPI serial data line. (If the channel you selected is off, switch it on.)  
The MOSI label for the source channel is automatically set.
  - Enter the MOSI signal threshold voltage level.  
The threshold voltage level is used in decoding, and it will become the trigger level when the trigger type is set to the selected serial decode slot.
- **MISO, Threshold, Delay** – (Optional) For the the SPI Master-In Slave-Out signal:
  - Select the channel that is connected to a second SPI serial data line. (If the channel you selected is off, switch it on.)  
The MISO label for the source channel is automatically set.

- Enter the MISO signal threshold voltage level.

The threshold voltage level is used in decoding, and it will become the trigger level when the trigger type is set to the selected serial decode slot.

- Select the number of bits to ignore (delay) before decoding the MISO stream.
- **Frame by** – Select a framing signal that the oscilloscope will use for determining which clock edge is the first clock edge in the serial stream.

You can set the oscilloscope to trigger during a high chip select (**CS**), a low chip select (**~CS**), or after a **Timeout** period during which the clock signal has been idle.

- If the framing signal is set to **CS** (or **~CS**), the first clock edge as defined, rising or falling, seen after the **CS** (or **~CS**) signal transitions from low to high (or high to low) is the first clock in the serial stream.

**CS** or **~CS** – Select the channel that is connected to the SPI frame line.

The label (**~CS** or **CS**) for the source channel is automatically set. The data pattern and the clock transition must occur during the time when the framing signal is valid. The framing signal must be valid for the entire data pattern.

**Threshold** – Enter the chip select signal threshold voltage level.

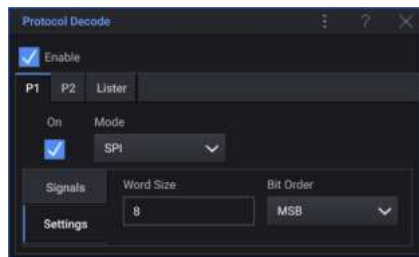
The threshold voltage level is used in decoding, and it will become the trigger level when the trigger type is set to the selected serial decode slot.

- If the framing signal is set to **Timeout**, the oscilloscope generates its own internal framing signal after it sees inactivity on the serial clock line.

**Timeout** – Set the minimum time that the Clock signal must be idle (not transitioning) before the oscilloscope will search for the Data pattern on which to trigger.

The Timeout value can be set anywhere from 100 ns to 10 s.

**Settings** The SPI protocol decode mode has these controls for decode settings:



- **Word Size** – Enter the number of bits in a word.

- **Bit Order** – Select the bit order, most significant bit first (MSB) or least significant bit first (LSB), used when displaying data in the serial decode waveform and in the Lister.
- Notes**
- SPI triggering and serial decode is included as a standard feature.
  - If the decode line does not appear on the display, press the **[Protocol Decode]** key to turn it on.
  - If the oscilloscope is stopped, press the **[Run/Stop]** key to acquire and decode data.
  - If the setup does not produce a stable trigger, the SPI signals may be slow enough that the oscilloscope is Auto triggering. Press the **[Mode]** key to set the trigger mode from **Auto** to **Trig'd**.
  - You can use the horizontal **[Zoom]** window for easier navigation of the decoded data.

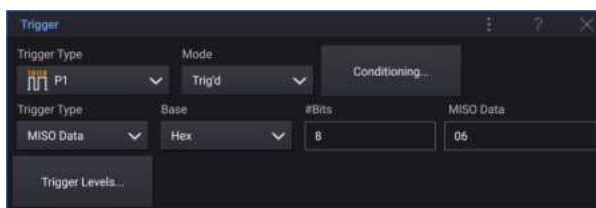
## SPI Triggering

To set up the oscilloscope to capture SPI signals, see "[SPI Protocol Setup](#)" on page 347.

After the oscilloscope has been set up to capture SPI signals, you can then trigger on a data pattern that occurs at the start of a frame. The serial data string can be specified to be from 4 to 32 bits long.

- 1 Select the trigger badge, or from the main menu, choose **Trigger > Setup...**
- 2 In the Trigger dialog box, from the **Trigger Type** drop-down list, select **Protocol 1: SPI** or **Protocol 2: SPI**.

The Trigger dialog box controls unique to the **PN: SPI** trigger type are:



- **Trigger Type** – Selects the trigger condition:
  - **Master-Out, Slave-In (MOSI) Data** – Triggers on the MOSI data signal.
  - **Master-In, Slave-Out (MISO) Data** – Triggers on the MISO data signal.
- **Base** – Selects between **Hex** or **Binary** data value entry.

The entered data value appears in both binary and hex formats in a separate dialog.

Use the **Binary** method if you need to enter "don't care" bits (X) within a nibble. If all bits in a nibble are "don't care", the hex nibble is displayed as "don't care" (X). When all bits in a nibble are 1s or 0s, the hex value is shown. Hex nibbles that contain a mix of 0/1 bits and "don't care" bits are displayed as "\$".

- **#Bits** – Enter the number of bits in the serial data string.

The number of bits in the string can be set anywhere from 4 bits to 64 bits. The data values for the serial string are displayed in the MOSI/MISO Data string in the waveform area.

- **MOSI Data** or **MISO Data** – Enter bit values of **0** (low), **1** (high), or **X** (don't care).

The data value is left-justified in the frame when setting up the trigger. If the base is **Hex**, the first digit represents the first 4 bits after the start of frame, continuing with the remaining digits in the data value.

## Interpreting SPI Decode



- Angled waveforms show an active bus (inside a packet/frame).
- Mid-level blue lines show an idle bus.
- The number of clocks in a frame appears in light-blue above the frame, to the right.
- Decoded hexadecimal data values appear in white.
- Decoded text is truncated at the end of the associated frame when there is insufficient space within frame boundaries.

- Pink vertical bars indicate you need to expand the horizontal scale (and run again) to see decode.
- Red dots in the decode line indicate that there is data that is not being displayed. Scroll or expand the horizontal scale to view the information.
- Aliased bus values (undersampled or indeterminate) are drawn in pink.
- Unknown bus values (undefined or error conditions) are drawn in red.

## Interpreting SPI Lister Data



In addition to the standard Time column, the SPI Lister contains these columns:

- Data – data bytes (MOSI and MISO).

Aliased data is highlighted in pink. When this happens, decrease the horizontal time/div setting and run again.

## Searching for SPI Data in the Lister

The oscilloscope's search capability lets you search for (and mark) certain types of SPI data in the Lister (see "[Searching Lister Data](#)" on page 121). Then, you can use the navigation controls to navigate through the marked rows (see "[Navigating the Time Base](#)" on page 52).

The Search dialog box controls unique to the **PN: SPI** search type selection are:



- **Search for** – Selects the decode value to find:
  - **Master-Out, Slave-In (MOSI) Data** – Finds MOSI data.
  - **Master-In, Slave-Out (MISO) Data** – Finds MISO data.
- **Words** – Enter the number of words in the data value.
- **Data** – Enter the hexadecimal data value.

The search pattern is always left-justified in the packet. If you want to search for a value in the second or higher word, increase the **Words** count and enter don't cares ('X's) for the earlier words.



# 29 UART/RS232/422/485 Triggering and Protocol Decode

UART/RS232/422/485 Protocol Decode Setup / 355

UART/RS232/422/485 Triggering / 358

Interpreting UART/RS232/422/485 Decode / 360

Interpreting UART/RS232/422/485 Lister Data / 361

Searching for UART/RS232/422/485 Data in the Lister / 361

UART/RS232/422/485 triggering and protocol decode is included with the Embedded Serial Analysis license.

## UART/RS232/422/485 Protocol Decode Setup

To enable UART/RS232/422/485 protocol decode:

**1** Press [**Protocol Decode**].

Or:

**a** From the main menu, choose **Analyze > Protocol Decode...**

**b** In the Protocol Decode dialog box, select **Enable**.

**c** Select either the **P1** or **P2** tab (the oscilloscope can decode two protocols at the same time), and select **On**.

**2** From the **Mode** drop-down list, select **UART/RS232**.

Below the **Mode** selection are vertical tabs for specifying **Signals**, **Bus Config**, and **Settings**.

**Signals** The UART/RS232/422/485 protocol decode mode Signals subtab has these controls for setting up the signals:



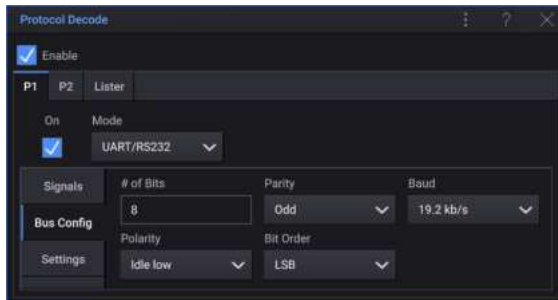
- **Rx, Tx** – Selects the analog or digital channels that are probing the receive and transmit signals.

The RX and TX labels for the source channels are automatically set.

- **Threshold** – Sets the threshold voltage levels for the receive and transmit signals.

The threshold voltage level is used in decoding and will become the trigger level when the trigger type is set to the selected serial decode bus.

**Bus Config** The UART/RS232/422/485 protocol decode mode Bus Config subtab has these controls for setting up the bus configuration:



- **# of Bits** – Sets the number of bits in the UART/RS232 words to match your device under test (selectable from 5-9 bits).
- **Parity** – Selects **Odd**, **Even**, or **None** as the parity being used in your device under test.
- **Baud** – Selects the baud rate of the signals in your device under test. You can select baud rates from 1.2 kb/s to 12 Mb/s.

If the desired baud rate is not listed, select **User Defined**; then, enter the desired baud rate in the **User Baud** field. You can set the user-defined UART baud rate from 100 b/s to 8.0000 Mb/s.

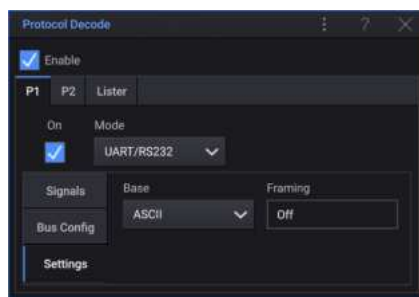
- **Polarity** – Selects **Idle low** or **Idle high** to match your device under test's state when at idle. For RS232 select **Idle low**.

- **Bit Order** – Selects whether the most significant bit, **MSB**, or the least significant bit, **LSB**, is presented after the start bit in the signal from your device under test. For RS232 select **LSB**.

**NOTE**

In the serial decode display, the most significant bit is always displayed on the left regardless of how **Bit Order** is set.

**Settings** The UART/RS232/422/485 protocol decode mode Settings subtab has these controls for decode settings:



- **Base** – Select the base, **Hex**, **Binary**, or **ASCII**, in which decoded words are displayed.
  - When displaying words in ASCII, the 7-bit ASCII format is used. Valid ASCII characters are between 0x00 and 0x7F. To display in ASCII you must select at least 7 bits in the Bus Configuration. If ASCII is selected and the data exceeds 0x7F, the data is displayed in hex.
  - When **# of Bits** is set to 9 in the Bus Configuration, the 9th (alert) bit is displayed directly to the left of the ASCII value (which is derived from the lower 8 bits).
- **Framing** – Enter a value that will be displayed in light blue in the decode display. A parity error overrides this setting and displays in red.

- Notes**
- UART/RS232/422/485 protocol decode and triggering is included as a standard feature.
  - If the decode line does not appear on the display, press the **[Protocol Decode]** key to turn it on.
  - If the oscilloscope is stopped, press the **[Run/Stop]** key to acquire and decode data.
  - If the setup does not produce a stable trigger, the UART/RS232 signals may be slow enough that the oscilloscope is Auto triggering. Press the **[Mode]** key to set the trigger mode from **Auto** to **Trig'd**.
  - You can use the horizontal **[Zoom]** window for easier navigation of the decoded data.

- See Also
- ["UART/RS232/422/485 Triggering"](#) on page 358
  - ["Interpreting UART/RS232/422/485 Decode"](#) on page 360
  - ["Interpreting UART/RS232/422/485 Lister Data"](#) on page 361
  - ["Searching for UART/RS232/422/485 Data in the Lister"](#) on page 361

## UART/RS232/422/485 Triggering

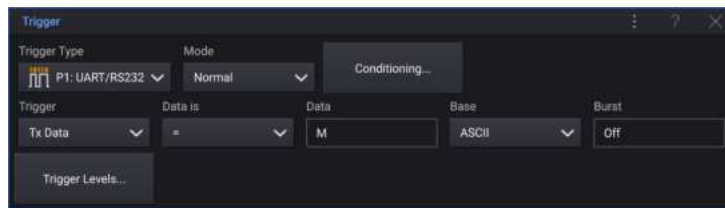
To trigger on a UART (Universal Asynchronous Receiver/Transmitter) signal, connect the oscilloscope to the Rx and Tx lines and set up a trigger condition. RS232 (Recommended Standard 232) is one example of a UART protocol.

To set up the oscilloscope to capture UART/RS232/422/485 signals, see ["UART/RS232/422/485 Protocol Decode Setup"](#) on page 355.

After you have set up the oscilloscope to capture UART/RS232/422/485 signals, you can then set up triggers.

- 1 Select the trigger badge, or from the main menu, choose **Trigger > Setup...**
- 2 In the Trigger dialog box, from the **Trigger Type** drop-down list, select **Protocol 1: UART/RS232** or **Protocol 2: UART/RS232**.

The Trigger dialog box controls unique to the **PN: UART/RS232** trigger type are:



- **Trigger** – Selects the trigger condition:
  - **Rx Start Bit, Tx Start Bit** – The oscilloscope triggers when a start bit occurs on Rx, Tx.
  - **Rx Stop Bit, Tx Stop Bit** – Triggers when a stop bit occurs on Rx, Tx. The trigger will occur on the first stop bit. This is done automatically whether the device under test uses 1, 1.5, or 2 stop bits. You do not need to specify the number of stop bits used by the device Under test.
  - **Rx Data, Tx Data** – Triggers on a data byte that you specify. For use when the device under test data words are from 5 to 8 bits in length (no 9th (alert) bit).
  - **Rx 1:Data, Tx 1:Data** – For use when the device under test data words are 9 bits in length including the alert bit (the 9th bit). Triggers only when the 9th (alert) bit is 1. The specified data byte applies to the least significant 8 bits (excludes the 9th (alert) bit).

- **Rx 0:Data, Tx 0:Data** – For use when the device under test data words are 9 bits in length including the alert bit (the 9th bit). Triggers only when the 9th (alert) bit is 0. The specified data byte applies to the least significant 8 bits (excludes the 9th (alert) bit).
- **Rx X:Data, Tx X:Data** – For use when the device under test data words are 9 bits in length including the alert bit (the 9th bit). Triggers on a data byte that you specify regardless of the value of the 9th (alert) bit. The specified data byte applies to the least significant 8 bits (excludes the 9th (alert) bit).
- **Rx Parity Error, Tx Parity Error** – Triggers on a parity error when parity is set in the bus configuration.

When you select a trigger condition that includes "**Data**" (for example: **Rx Data**):

- **Data is** – Selects an equality qualifier. You can choose **= (Equal)**, **≠ (Not equal)**, **< (Less than)**, or **> (Greater than)** a specific data value.
- **Data** – Specifies the data value.
- **Base** – Selects the format in which you would like to enter data values to trigger on, **Hex** or **ASCII**.

Note that this setting does not affect the base used in the decode display.

- **Burst** – Lets you trigger on the Nth frame (1-4096) after an **Idle** time you enter. All trigger conditions must be met for the trigger to occur.

**Idle** times from 1  $\mu$ s to 10 s can be entered. The oscilloscope will look for a trigger condition only after the **Idle** time has past.

## Interpreting UART/RS232/422/485 Decode



- Angled waveforms show an active bus (inside a packet/frame).
- Mid-level blue lines show an idle bus.
- When using 5–8 bit formats, the decoded data is displayed in white (in binary, hex, or ASCII).
- When using the 9 bit format, all data words are displayed in green, including the 9th bit. The 9th bit is displayed on the left.
- When a data word value is selected for framing, it is displayed in light blue. When using 9-bit data words, the 9th bit will also be displayed in light blue.
- Decoded text is truncated at the end of the associated frame when there is insufficient space within frame boundaries.
- Pink vertical bars indicate you need to expand the horizontal scale (and run again) to see decode.
- When the horizontal scale setting does not permit the display of all available decoded data, red dots will appear in the decoded bus to mark the location of hidden data. Expand the horizontal scale to allow the data to display.
- An unknown (undefined) bus is shown in red.
- A parity error will cause the associated data word to be shown in red, which includes the 5–8 data bits and the optional 9th bit.

## Interpreting UART/RS232/422/485 Lister Data



In addition to the standard Time column, the UART/RS232 Lister contains these columns:

- Rx – receive data.
- Tx – transmit data.
- Errors – highlighted in red, Parity Error or Unknown Error.

Aliased data is highlighted in pink. When this happens, decrease the horizontal time/div setting and run again.

## Searching for UART/RS232/422/485 Data in the Lister

The oscilloscope's search capability lets you search for (and mark) certain types of UART/RS232/422/485 data in the Lister (see "[Searching Lister Data](#)" on page 121). Then, you can use the navigation controls to navigate through the marked rows (see "[Navigating the Time Base](#)" on page 52).

The Search dialog box controls unique to the **PN: UART/RS232** search type selection are:

- **Search for** – Selects the decode value to find:
  - **Rx Data** – Finds a data byte that you specify. For use when the DUT data words are from 5 to 8 bits in length (no 9th (alert) bit).

- **Rx 1:Data** – For use when the DUT data words are 9 bits in length including the alert bit (the 9th bit). Finds only when the 9th (alert) bit is 1. The specified data byte applies to the least significant 8 bits (excludes the 9th (alert) bit)
- **Rx 0:Data** – For use when the DUT data words are 9 bits in length including the alert bit (the 9th bit). Finds only when the 9th (alert) bit is 0. The specified data byte applies to the least significant 8 bits (excludes the 9th (alert) bit).
- **Rx X:Data** – For use when the DUT data words are 9 bits in length including the alert bit (the 9th bit). Finds a data byte that you specify regardless of the value of the 9th (alert) bit. The specified data byte applies to the least significant 8 bits (excludes the 9th (alert) bit).
- Similar choices are available for Tx.
- **Rx Parity Error, Tx Parity Error** – Finds a parity error based on the parity you have set in the Bus Configuration Menu.
- **Rx or Tx Any Error** – Finds any error.

# Index

## Symbols

- (-) Width measurement, 199
- (+) Width measurement, 198

## Numerics

- 1 M ohm input impedance, 58
- 50 ohm input impedance, 58

## A

- About Oscilloscope, 290
- absolute value math function, 81
- AC channel coupling, 58
- AC RMS - Full Screen measurement, 195
- AC RMS - N Cycles measurement, 195
- accessories, 19, 307
- acquire, 161
- acquisition memory, 136
- acquisition mode, 166
- acquisition mode, averaging, 169
- acquisition mode, normal, 167
- acquisition mode, peak detect, 167
- acquisition modes, 161
- active serial bus, 336, 344, 351, 360
- activity indicator, 108
- actual sample rate, 165
- addition math function, 79
- address with no ack condition, I2C trigger, 334
- address, I2C trigger, 334
- adjacent channel power ratio (ACPR) FFT analysis measurement, 206
- aliasing, 162
- alternating edge trigger, 138
- AM (amplitude modulation), waveform generator output, 258
- Amplitude measurement, 191
- amplitude modulation (AM), waveform generator output, 258
- analog channel inputs, 21
- analog channel, probe attenuation, 61
- analog channel, setup, 55
- analog filters, adjusting, 65, 89
- Analyze Segments, 172, 173
- annotation, adding, 130
- arbitrary generated waveforms, editing, 254
- arbitrary waveform generator output, 250

- arbitrary waveforms, copying from other sources, 256
- arbitrary waveforms, creating new, 254
- arbitrary waveforms, editing existing, 256
- Area - Full Screen measurement, 204
- Area - N Cycles measurement, 205
- ASCII file format, 262
- ASCII XY data, 265
- attenuation, probe, 61
- attenuation, probe, external trigger, 160
- attenuators, 62
- Auto Scale key, 32
- Auto Setup. Fault Hunter, 242
- Auto trigger mode, 154
- Auto? trigger indicator, 155
- AutoIP, 275, 276
- automatic measurements, 185, 188
- automatic setup, 106
- AutoProbe interface, 21, 58
- Autoscale preferences, 280
- Autoscale, digital channels, 106
- AUX OUT connector, 24, 282
- AUX OUT signal and zone qualified trigger, 151
- AUX TRIG IN connector, 24
- Average - Full Screen measurement, 194
- Average - N Cycles measurement, 194
- average measurement trend, 95
- averaged value math function, 90
- averaging acquire mode, 166, 169
- Ax + B math function, 81

## B

- back panel inputs and outputs, 22
- badges, 36
- Band Pass Filter math function, 91
- bandwidth, 3, 290
- bandwidth limit, 59
- bandwidth required, oscilloscope, 165
- bandwidth, oscilloscope, 163
- Bartlett FFT window, 68
- base 10 exponential math function, 82
- Base measurement, 192
- BIN file format, 262
- binary data (.bin), 309
- binary data file examples, 312
- binary data in MATLAB, 310
- binary data, example program for reading, 312
- Binary marker mode, 178
- bit rate measurement, 199

- bits, SPI trigger, 351
- Blackman Harris FFT window, 68
- BMP file format, 262
- Bode plot, frequency response analysis, 247
- brick-wall frequency response, 163
- Browser Web Control, 295
- built-in help, 43
- burst width measurements, 199
- burst, capture signal bursts, 171
- bus display mode, 110
- BW Limit? in DVM display, 236

## C

- calibrate probe, 62
- calibration, 288
- calibration status, 301
- CAN decode, source channels, 320
- CAN FD standard, 322
- CAN symbolic data, 323
- CAN trigger, 324
- CAN XL standard, 322
- capture signal bursts, 171
- cardiac waveform generator output, 252
- Center, FFT, 67, 89
- change network password, 303
- channel power FFT analysis measurement, 205
- channel, analog, 55
- channel, bandwidth limit, 59
- channel, coupling, 57
- channel, fine adjustment, 59
- channel, invert, 60
- channel, on/off keys, 33
- channel, position, 57
- channel, probe external scaling, 63
- channel, probe units, 61
- channel, skew, 62
- channel, vertical sensitivity, 57
- characteristics, 305
- choosing values, 32
- cleaning, 290
- clear display, 126, 168
- clear display, Quick Clear Display, 292
- clear persistence, 125
- clock, oscilloscope date/time, 281
- CMOS threshold, 110
- Common Logarithm math function, 83
- compensate passive probes, 22, 29
- connect probes, digital, 103
- connection, to a PC, 276

connections for frequency response analysis (FRA), 245  
 Control Instrument, web browser interface, 295  
 control, remote, 273  
 copyright, 2  
 Counter measurement, 198  
 counters, 237  
 coupling, channel, 57  
 coupling, trigger, 155  
 crosstalk problems, 65, 89  
 CSV data, 265  
 CSV file format, 262  
 CSV files, minimum and maximum values, 316  
 custom location, time reference, 50

## D

D\*, 33  
 d/dt math function, 83  
 damage, shipping, 19  
 data sheet, 305  
 DC channel coupling, 58  
 DC offset correction for integrate waveform, 85  
 DC RMS - Full Screen measurement, 194  
 DC RMS - N Cycles measurement, 194  
 DC signals, checking, 155  
 DC waveform generator output, 251  
 DDR burst, random trigger holdoff, 159  
 dead time (re-arm), 173  
 decaying average approximation, 91  
 decibels, FFT vertical units, 68  
 decimating samples, 166  
 decimation, for analysis record, 316  
 decimation, for screen, 316  
 default configuration, 27  
 default setup, 27  
 Default Setup key, 32  
 defaults, waveform generator, 253  
 delay knob, 47  
 Delay measurement, 189, 200  
 delay time indicator, 51  
 delayed sweep, 48  
 delete file, 277  
 depth, AM modulation, 258  
 detection type, FFT (Magnitude), 68  
 deviation, FM modulation, 259  
 DHCP, 275, 276  
 differentiate math function, 83  
 digital bus mode, 110  
 digital channel inputs, 24  
 digital channels, Autoscale, 106  
 digital channels, logic threshold, 110  
 digital channels, probing, 113  
 digital channels, size, 108  
 digital display, interpreting, 107  
 Digital key, 33  
 digital probes, 103, 113  
 digital probes, impedance, 113

digital voltmeter (DVM), 235  
 Digitizer mode, 174  
 digits, counter resolution, 237  
 disable network password, 303  
 display multiple acquisitions, 162  
 display, clear, 126  
 display, persistence, 124  
 display, signal detail, 132  
 distortion problems, 65, 89  
 Divide math function, 79  
 DNS IP, 276  
 Drag Waveforms mode, 40  
 Draw Box mode, 40  
 Duty cycle measurement, 199  
 duty cycle measurement trend, 95  
 DVM (digital voltmeter), 235

## E

ECL threshold, 110  
 edge speeds, 165  
 edge triggering, 137  
 editing measurements, 188  
 EEPROM data read, I2C trigger, 334  
 either edge trigger, 138  
 eject USB storage device, 278  
 e-mail setups, images, or data, 267  
 e-mail, Quick Email, 292  
 energy of a pulse, 85  
 English user interface and Quick Help, 26  
 enhanced security options, 283  
 Entry knob, 32  
 Entry knob, push to select, 32  
 envelope math function, 91  
 environmental conditions, 307  
 erase, secure, 272  
 event table, 120  
 exFAT file system format not supported, 278  
 expand about, 57, 279  
 expand about center, 279  
 expand about ground, 279  
 exponential fall waveform generator output, 251  
 Exponential math function, 84  
 exponential rise waveform generator output, 251  
 exporting waveform, 261  
 EXT2 file system format, 278  
 EXT3 file system format, 278  
 EXT4 file system format, 278  
 external memory device, 22  
 external scaling, probe, 63  
 external trigger, 159  
 external trigger, input impedance, 160  
 external trigger, probe attenuation, 160  
 external trigger, probe units, 160

## F

factory default, 271  
 Fall time measurement, 200  
 fall time measurement trend, 95  
 falling edges count measurements, 204  
 FAT file system format, 278  
 FAT16 file system format, 278  
 FAT32 file system format, 278  
 Fault Hunter, 239  
 Fault Hunter View dialog box, 241  
 favorites menu, 40  
 FFT (Magnitude) detection type, 68  
 FFT aliasing, 72  
 FFT analysis measurements, 205  
 FFT Auto Setup, 67, 89, 90  
 FFT DC value, 72  
 FFT gating, 68  
 FFT magnitude math function, 88  
 FFT math function, 65  
 FFT math functions, 88  
 FFT measurement hints, 71  
 FFT peaks, searching, 70  
 FFT phase math function, 88  
 FFT resolution, 71  
 FFT spectral leakage, 73  
 FFT units, 72  
 FFT vertical units, 68  
 FFT window, 68  
 file explorer, 277  
 file format, ASCII, 262  
 file format, BIN, 262  
 file format, BMP, 262  
 file format, CSV, 262  
 file format, PNG, 262  
 file, save, recall, load, 277  
 filter math function, averaged value, 90  
 filter math function, envelope, 91  
 filter math function, high pass and low pass, 92  
 filter math function, smoothing, 92  
 filters, math, 90  
 fine adjustment, channel, 59  
 fine adjustment, horizontal scale, 50  
 firmware updates, 308  
 firmware upgrade files, 301  
 firmware version, 290  
 firmware versions, 301  
 flash drive, 22  
 Flat top FFT window, 68  
 FM (frequency modulation), waveform generator output, 259  
 folding frequency, 162  
 Force key, 32  
 forcing a trigger, 137  
 FRA (frequency response analysis), 245  
 frame trigger, I2C, 334  
 frame, LIN symbolic, 343  
 French front panel overlays, 34  
 French user interface and Quick Help, 26  
 frequency counter, 237  
 frequency data in CSV files, 316

- frequency deviation, FM modulation, 259
  - Frequency measurement, 197
  - frequency measurement trend, 95
  - frequency modulation (FM), waveform generator output, 259
  - frequency peaks, searching, 70
  - frequency requirements, power source, 25
  - frequency response analysis (FRA), 245
  - frequency response analysis data, email, 248
  - frequency response analysis data, save, 248
  - frequency, Nyquist, 162
  - front panel inputs and outputs, 21
  - front panel keys and knobs, 30
  - front panel self test, 289
  - front panel, language overlay, 34
- G**
- gated by markers measurement window, 209
  - gateway IP, 276
  - Gaussian frequency response, 164
  - Gaussian pulse waveform generator output, 252
  - GEN OUT connector, 23
  - German front panel overlays, 34
  - German noise requirements, 317
  - German user interface and Quick Help, 26
  - glitch capture, 167
  - glitch trigger, 139
  - global bandwidth limit, 171
  - golden waveform test, 221
  - grabber, 105, 106
  - graph, histogram, 218
  - graphical user interface language, 26
  - graticule intensity, 127
  - graticule options, 126
  - grid intensity, 127
  - grid options, 126
  - ground level, 56
  - Ground terminal, 22
  - GUI scale factor, 281
- H**
- Hanning FFT window, 68
  - hardware self test, 288
  - HD300AUTA license, 308
  - HD300EMBA license, 308
  - help, built-in, 43
  - hex bus trigger, 143
  - Hex marker mode, 178
  - HF Reject, 157
  - high pass filter math function, 92
  - high-frequency noise rejection, 157
  - high-resolution mode, 166
  - histogram, 213
  - histogram graph, 218
  - histogram statistics, 219
  - histogram statistics, quick reset, 291
  - histogram, measurement, 214, 217
  - holdoff, 158
  - Horiz key, 49
  - horizontal position control, 32
  - horizontal position knob, 47
  - horizontal scale fine adjustment, 50
  - horizontal sweep speed control, 32
  - horizontal time/div control, 32
  - horizontal Zoom key, 32
  - host ID, 290
  - host name, 276, 293
  - hysteresis, trigger, 158
- I**
- I/O interface settings, 273
  - I2C trigger, 333
  - identification function, web interface, 300
  - idle serial bus, 336, 344, 351, 360
  - impedance, analog channel input, 58
  - impedance, digital probes, 113
  - indeterminate state, 179
  - infinite persistence, 125, 162, 167
  - input impedance, analog channel, 58
  - installed licenses, 290
  - installed options, 301
  - instantaneous slope of a waveform, 83
  - Instrument Utilities web page, 301
  - Integrate math function, 84
  - intensity control, 132
  - invert waveform, 60
  - invert waveform generator output, 253
  - IP address, 276, 293
  - Italian front panel overlays, 34
  - Italian user interface and Quick Help, 26
- J**
- Japanese front panel overlays, 34
  - Japanese user interface and Quick Help, 26
- K**
- Keysight IO Libraries Suite, 296
  - Korean front panel overlays, 35
  - Korean user interface and Quick Help, 26
- L**
- label list, 129
  - label list, loading from text file, 129
  - labels, 127
  - labels, auto-increment, 129
  - labels, reset library, 130
  - LAN connection, 275
  - LAN interface, remote control, 273
  - LAN port, 23
  - language, user interface, 26
  - layout, waveform, 123
  - length control, 265
  - length softkey, 264
  - level, trigger, 136
  - LF Reject, 156
  - library, labels, 128
  - license files, 301
  - licenses, 308
  - limit testing, measurement, 211
  - LIN decode, source channels, 340
  - LIN symbolic data, 342
  - LIN trigger, 342
  - line voltage, 25
  - load file, 277
  - localized front panel overlay, 34
  - logging remote commands, 282
  - logic presets, waveform generator, 252
  - logic threshold, 110
  - low pass filter math function, 92
  - low-frequency noise rejection, 156
- M**
- magnify math function, 93
  - Manual marker mode, 178
  - marker measurements, 177
  - marker units, 180
  - Markers key, 33
  - markers, dragging, 40
  - markers, gated measurement window, 209
  - markings, product, 317
  - mask file, building, 229
  - mask files, recall, 270
  - mask region limit per pixel column, 232
  - mask statistics, quick reset, 291
  - mask test, trigger output, 224, 254, 282
  - mask testing, 221
  - mask testing, how it works, 232
  - mask, AUX OUT signal, 254, 282
  - math filters, 90
  - math functions, cascaded, 76
  - math operators, 78
  - math transforms, 80
  - math visualizations, 93
  - math, 1\*2, 79
  - math, 1/2, 79
  - math, addition, 79
  - math, differentiate, 83
  - math, divide, 79
  - math, FFT, 65
  - math, FFT magnitude/phase, 88
  - math, functions, 75
  - math, integrate, 84
  - math, multiply, 79
  - math, offset, 77
  - math, scale, 77
  - math, subtract, 79
  - math, units, 78

math, using waveform math, 75  
 MATLAB binary data, 310  
 Max Envelope math function, 94  
 Max Hold math function, 94  
 maximum input voltages, 306  
 Maximum math function, 94  
 Maximum measurement, 191  
 maximum sample rate, 165  
 Measure marker mode, 178  
 Measure menu, 185  
 measure statistics, quick reset, 291  
 measure, Quick Measure, 291  
 measurement category, definitions, 306  
 measurement definitions, 188  
 measurement histogram, 214, 217  
 measurement limit testing, 211  
 measurement statistics, 209  
 measurement thresholds, 207  
 measurement trend math function, 94  
 measurement window, 209  
 measurements, 188  
 measurements, automatic, 185  
 measurements, delay, 189  
 measurements, edit, 188  
 measurements, overshoot, 189  
 measurements, phase, 189  
 measurements, preshoot, 189  
 measurements, time, 196  
 measurements, voltage, 190  
 MegaZoom IV, 4  
 memory depth, 3  
 memory depth and sample rate, 165  
 memory, segmented, 171  
 menu, main, 36  
 Message Log, 40  
 Message Log button, 40  
 message, CAN symbolic, 326  
 Min Envelope math function, 94  
 Min Hold math function, 94  
 Minimum math function, 94  
 Minimum measurement, 191  
 missing acknowledge condition, I2C trigger, 334  
 Mode key, 32  
 model number, 290, 293  
 modulation, waveform generator output, 257  
 module installed, 290  
 MSO, 3  
 Multicast DNS, 275  
 Multiply math function, 79

## N

N8900A Infiniium Offline oscilloscope analysis software, 262  
 natural logarithm math function, 86  
 navigate files, 277  
 navigating the time base, 52  
 negative pulse width measurement trend, 95

network configuration parameters, 293  
 network, connecting to, 275  
 new label, 128  
 noise rejection, 157  
 noise waveform generator output, 251  
 noise, adding to waveform generator output, 252  
 noise, high-frequency, 157  
 noise, low-frequency, 156  
 noisy signals, 154  
 non-volatile memory, secure erase, 272  
 normal acquire mode, 167  
 normal mode, 166, 167  
 notices, 2  
 NTFS file system format, 278  
 number of negative pulses measurements, 203  
 number of positive pulses measurements, 203  
 Nyquist frequency, 72  
 Nyquist sampling theory, 162

## O

occupied bandwidth FFT analysis measurement, 205  
 offset (DC) correction for integrate waveform, 85  
 online help, 43  
 operators, math, 78  
 OR trigger, 144  
 oscilloscope bandwidth, 163  
 oscilloscope bandwidth required, 165  
 oscilloscope rise time, 164  
 oscilloscope sample rate, 164  
 output load expected, waveform generator, 253  
 output settings, waveform generator, 253  
 output, trigger, 282  
 overlay, localized, 34  
 Overshoot measurement, 189, 192  
 overvoltage category, 307

## P

pan and zoom, 46  
 passive probes, compensating, 29  
 password (network), change or disable, 303  
 password (network), setting, 302  
 pattern trigger, 141  
 pattern, SPI trigger, 351  
 PC connection, 276  
 peak detect mode, 166, 167  
 Peak-peak measurement, 191  
 period counter, 237  
 Period measurement, 197  
 period measurement trend, 95  
 persistence, 124  
 persistence, clearing, 125

persistence, infinite, 162  
 Phase measurement, 189, 201  
 phase X marker units, 180  
 PNG file format, 262  
 points per span, FFT (Magnitude), 69  
 point-to-point connection, 276  
 pollution degree, 307  
 pollution degree, definitions, 307  
 Portuguese front panel overlays, 35  
 Portuguese user interface and Quick Help, 26  
 position digital channels, 109  
 position, analog, 57  
 positive pulse width measurement trend, 95  
 post-processing, 185  
 post-trigger information, 47  
 power consumption, 25  
 power cord connector, 23  
 power cycle the oscilloscope, 25  
 power requirements, 25  
 power supply, 23  
 power switch, 21, 25  
 power-on, 25  
 predefined labels, 128  
 Preshoot measurement, 189, 193  
 pre-trigger information, 47  
 probe attenuation, 61  
 probe attenuation, external trigger, 160  
 Probe Comp terminal, 22  
 probe compensation, 22  
 probe external scaling, 63  
 probe head, 62  
 probe units, 61  
 probe, AutoProbe interface, 21  
 probe, calibrate, 62  
 probes, 307  
 probes, connecting to oscilloscope, 26  
 probes, digital, 103  
 probes, passive, compensating, 29  
 programmer's guide, 296  
 Protocol Decode key, 33  
 Protocol Listing, 120  
 pulse polarity, 140  
 pulse waveform generator output, 251  
 pulse width trigger, 139

## Q

qualifier, pulse width, 140  
 Quick Action menu item, 291  
 Quick Clear Display, 292  
 Quick Email, 292  
 Quick Histogram Statistics Reset, 291  
 Quick Mask Statistics Reset, 291  
 Quick Measure, 291  
 Quick Measure Statistics Reset, 291  
 Quick Recall, 292  
 Quick Save, 292  
 Quick Selection button, 37, 56  
 Quick Trigger Mode, 292

## R

ramp waveform generator output, 251  
 random noise, 154  
 random trigger holdoff, 159  
 ratio measurement, 196  
 ratio measurement trend, 95  
 ratio X marker units, 180  
 ratio Y marker units, 180  
 raw acquisition record, 265  
 re-arm time, 173  
 recall, 292  
 recall files via web interface, 299  
 recall mask files, 270  
 recall setups, 270  
 recall, Quick Recall, 292  
 Rectangular FFT window, 68  
 reference point, waveform, 279  
 reference waveforms, 99  
 regulatory information, 317  
 remote commands, logging, 282  
 remote control, 273  
 Remote Front Panel, 295  
 remote GUI access, VNC, 297  
 remote programming, Keysight IO Libraries, 296  
 remote programming, web interface, 295  
 required oscilloscope bandwidth, 165  
 reset label library, 130  
 restart condition, I2C trigger, 333  
 Results area, 42  
 results, frequency response analysis (FRA), 247  
 return instrument for service, 291  
 Rise time measurement, 199  
 rise time measurement trend, 95  
 rise time, oscilloscope, 164  
 rise time, signal, 165  
 rise/fall time triggering, 144  
 rising edge count measurements, 204  
 RMS - AC measurement trend, 95  
 RS232 trigger, 358  
 Run/Stop key, 31  
 running acquisition record, 265  
 runt pulses, 197  
 runt triggering, 146

## S

sample rate, 3  
 sample rate and memory depth, 165  
 sample rate, current rate displayed, 46  
 sample rate, oscilloscope, 163, 164  
 sampling theory, 162  
 sampling, overview, 162  
 save, 292  
 save file, 277  
 save files via web interface, 298  
 Save Screen key, 33  
 save segment, 264  
 save setup files, 263  
 save times, data, 266  
 save, Quick Save, 292  
 save/recall from web interface, 298  
 saver, screen, 279  
 saving data, 261  
 SCL (serial clock), I2C trigger, 332  
 SCPI Commands window, 295  
 screen image via web interface, 297  
 screen saver, 279  
 SDA, 331  
 SDA (serial data), I2C trigger, 332  
 secure erase, 272  
 security options, enhanced, 283  
 segmented memory, 171  
 segmented memory, re-arm time, 173  
 segmented memory, saving segments, 264  
 segmented memory, statistical data, 173  
 selecting, values, 32  
 self test, front panel, 289  
 self test, hardware, 288  
 serial data, 331  
 serial number, 290, 293  
 service functions, 287  
 setup and hold triggering, 147  
 setup files, saving, 263  
 setup, automatic, 106  
 setup, default, 27  
 setup, frequency response analysis (FRA), 246  
 setups, recall, 270  
 shipping damage, 19  
 shipping precautions, 291  
 shut down the oscilloscope, 26  
 Sigma, minimum, 224  
 signal, CAN symbolic, 326  
 signal, LIN symbolic, 343  
 Simplified Chinese front panel overlays, 35  
 Simplified Chinese user interface and Quick Help, 26  
 sinc waveform generator output, 251  
 sine waveform generator output, 250  
 single acquisition, 31  
 Single key, 31, 161  
 single-shot acquisitions, 155  
 single-shot events, 161  
 single-shot infinite persistence, 125  
 size, 108  
 skew, analog channel, 62  
 Slew Rate measurement, 205  
 Slope key, 32  
 slope trigger, 137  
 smoothing math function, 92  
 software updates, 308  
 Span, FFT, 67, 89  
 Spanish front panel overlays, 35  
 Spanish user interface and Quick Help, 26  
 specifications, 305  
 spectral leakage, FFT, 73  
 SPI trigger, 350  
 square root, 87  
 square waveform generator output, 250

square waves, 164  
 Squared math function, 88  
 stand-alone connection, 276  
 start acquisition, 31  
 start condition, I2C, 333  
 Start Freq, FFT, 67, 89  
 statistics, histogram, 219  
 statistics, mask test, 225  
 statistics, measurement, 209  
 statistics, using segmented memory, 173  
 status, User Cal, 287  
 Std Deviation measurement, 195  
 stop acquisition, 31  
 stop condition, I2C, 333  
 Stop Freq, FFT, 67, 89  
 subnet mask, 276  
 subtract math function, 79  
 sweep frequencies, frequency response analysis, 247  
 swu files, 277  
 symbolic data, CAN, 323  
 symbolic data, LIN, 342  
 sync pulse, waveform generator, 254

## T

template, front panel, 34  
 test, mask, 221  
 Thai front panel overlays, 35  
 Thai user interface and Quick Help, 26  
 theory, sampling, 162  
 threshold, analog channel measurements, 207  
 threshold, digital channels, 110  
 thumb drive, 22  
 tilt for viewing, 24  
 Time at Edge measurement, 200  
 time measurements, 196  
 time reference indicator, 51  
 time, re-arm, 173  
 times for saving data, 266  
 Top measurement, 191  
 total harmonic distortion (THD) FFT analysis measurement, 206  
 totalize counter, 237  
 Touch key, 33, 35  
 touchscreen user interface, 35  
 Track Waveform marker mode, 178  
 Traditional Chinese front panel overlays, 35  
 Traditional Chinese user interface and Quick Help, 26  
 transforms, math, 80  
 Transparent backgrounds, 279  
 Trig'd trigger indicator, 155  
 Trig'd trigger mode, 154  
 Trig'd? trigger indicator, 155  
 trigger coupling, 155  
 trigger Force key, 32  
 trigger hysteresis, 158  
 trigger indicator, Auto?, 155  
 trigger indicator, Trig'd, 155

- trigger indicator, Trig'd?, 155
- trigger level, 136
- trigger Level knob, 32
- trigger Mode key, 32
- trigger mode, Auto or Trig'd, 154
- trigger mode, Quick Trigger Mode, 292
- trigger output, 282
- trigger output, mask test, 224, 254, 282
- trigger qualified event signal,
  - counting, 238
- trigger Slope key, 32
- trigger type, CAN, 324
- trigger type, edge, 137
- trigger type, glitch, 139
- trigger type, hex bus, 143
- trigger type, I2C, 333
- trigger type, LIN, 342
- trigger type, OR, 144
- trigger type, pattern, 141
- trigger type, pulse width, 139
- trigger type, rise/fall time, 144
- trigger type, RS232, 358
- trigger type, runt, 146
- trigger type, setup and hold, 147
- trigger type, slope, 137
- trigger type, SPI, 350
- trigger type, UART, 358
- trigger types, 135
- trigger, definition, 136
- trigger, external, 159
- trigger, forcing a, 137
- trigger, general information, 136
- trigger, holdoff, 158
- trigger, mode and conditioning, 153
- trigger, source, 138
- trigger, zone qualified, 149
- triggers, AUX OUT signal, 254, 282
- TTL threshold, 110
- turn channel on, 33

## U

- UART trigger, 358
- under-sampled signals, 162
- Undo button, 28, 107
- units, external trigger probe, 160
- units, marker, 180
- units, math, 78
- units, probe, 61
- updating software and firmware, 308
- upgrade files, 301
- upgrade options, 308
- USB device port, 23
- USB device port, remote control, 273
- USB host port, 23
- USB host ports, 22
- USB storage device, 22
- USB storage devices, 278
- USB, CD device, 278
- USB, eject device, 22
- user calibration, 288

- user interface language, 26
- User-defined threshold, 110
- utilities, 273

## V

- V RMS, FFT vertical units, 68
- values, choosing, 32
- variable persistence, 125
- ventilation requirements, 25
- vertical expansion, 57
- vertical offset, 57
- vertical position, 57
- vertical position knob, 33
- vertical resolution, 171
- vertical scale knob, 33
- vertical sensitivity, 33, 57
- viewing, tilt the instrument, 24
- VISA connect string, 293
- visualizations, math, 93
- VNC, remote GUI access, 297
- voltage measurements, 190

## W

- warranted specifications, 305
- warranty, 2, 290
- Wave Gen key, 23, 33
- waveform generator, 249
- waveform generator amplitude, frequency
  - response analysis, 247
- waveform generator defaults,
  - restoring, 253
- waveform generator expected output
  - load, 253
- waveform generator logic presets, 252
- waveform generator output settings, 253
- waveform generator sync pulse, AUX OUT
  - signal, 254, 282
- waveform generator, arbitrary
  - waveforms, 254
- waveform generator, invert output, 253
- waveform generator, waveform type, 249
- waveform labels, 127
- waveform layout, 123
- waveform type, waveform generator, 249
- waveform, intensity, 132
- waveform, reference point, 279
- waveform, saving/exporting, 261
- web interface, 293
- web interface, accessing, 294
- white noise, adding to waveform generator
  - output, 252
- Width - measurement, 199
- Width + measurement, 198
- write data with no ack condition, I2C
  - trigger, 334

## X

- X at Max Y measurement, 202
- X at Max Y on FFT, 190
- X at Min Y measurement, 203
- X at Min Y on FFT, 190
- X marker level knob, 33

## Y

- Y at X measurement, 191
- Y marker level knob, 33

## Z

- zero phase reference, FFT (Phase), 89
- zone qualified trigger, 149
- zoom and pan, 46
- zoom display measurement window, 209
- Zoom key, 32
- Z-order for waveforms in grid, 127