

N8900 Series Autoranging System DC Power Supplies

N8920A-N8924A (5 kW, 208 VAC)

N8925A-N8930A (10 kW, 208 VAC)

N8931A-N8937A (15 kW, 208 VAC)

N8940A-N8944A (5 kW, 400 VAC)

N8945A-N8950A (10 kW, 400 VAC)

N8951A-N8957A (15 kW, 400 VAC)



Family of Affordable, Autoranging System DC Power Supplies

The Keysight Technologies N8900 Series provides 5, 10, and 15 kW autoranging, single-output programmable DC power for ATE applications that require just the right amount of performance at just the right price. The N8900 Series power supplies' autoranging output characteristic enables unprecedented flexibility by offering a wide range of voltage and current combinations at full power. Power supplies with "rectangular," or traditional, output characteristics provide full power at only one voltage and current combination. Just one N8900 does the job of multiple power supplies. It's like having many power supplies in one!

The N8900 Series provides stable output power, built-in voltage and current measurements, and autoranging output voltage and current from 80 to 1500 V and 20 to 510 A. These supplies offer many system-ready features like multiple standard I/O interfaces to simplify and accelerate test-system development and compact 3U design to save rack space. If more power is required, easily parallel multiple N8900 units to create "one" power supply with > 100 kW of total output power. The built-in primary/secondary control enables programming as if it's just one big power supply; no need to program each supply individually.

Autoranging output – does the job of multiple power supplies

The N8900 power supplies' autoranging output characteristic makes it much more flexible than rectangular, or traditional, output characteristic power supplies because they expand the power curve, giving the user more voltage and current combinations in one power supply. It's like having many rectangular power supplies in one. For example, the 1000 V, 30 A, 10 kW model is capable of 1000 V and 10 A at 10 kW as well as 333.3 V and 30 A at 10 kW. If it were a rectangular output, the specifications would be 1000 V, 10 A, 10 kW. At 333.3 V it would only be able to output 3.3 kW, not the 10 kW of an autoranging output. Figures 1 and 2 show a graphical representation of this example.

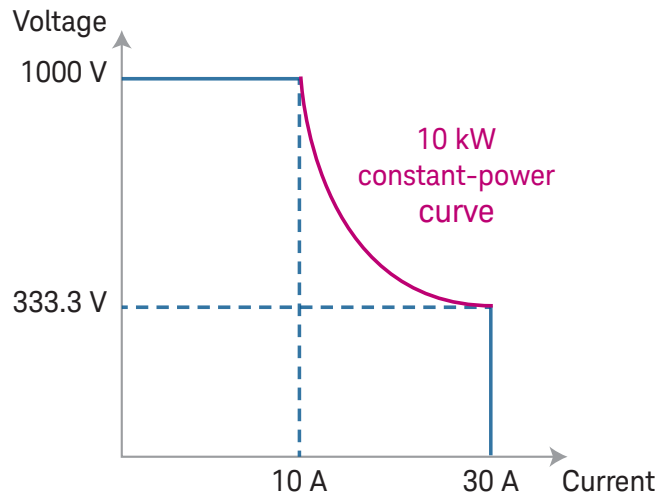

Figure 1. Autoranging output characteristic

- Autoranging output – does the job of multiple power supplies!
- 5, 10, and 15 kW maximum output power
- Up to 1500 V and up to 510 A
- 14 different voltage, current, and power combinations available in 208 or 400 VAC (28 total models)
- Just the right amount of performance at just the right price
- Easily parallel units to create "one" power supply with > 100 kW of power
- Built-in voltage and current measurement
- High power density, 15 kW in only 3U (5.25 inch/13.34 cm)
- Protection from over-voltage, over-current, and over-temperature
- LAN (LXI Core), USB, GPIB, and analog interfaces all standard



Autoranging output – like having many power supplies in one!

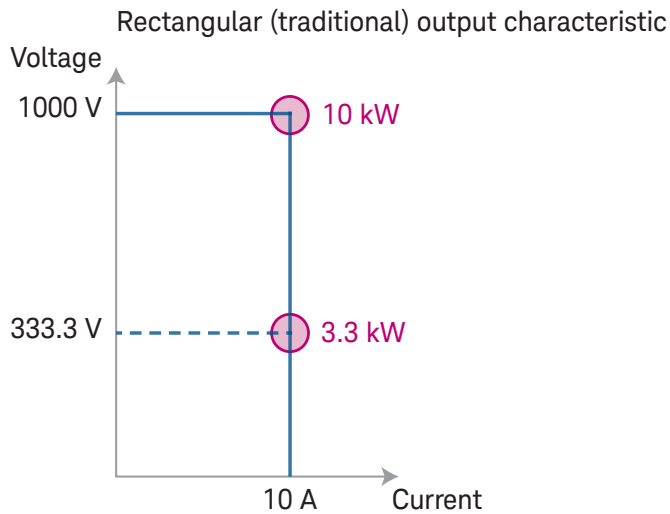

Figure 2. Rectangular output characteristic

Easy front-panel operation

Using the front panel controls, you have complete access to all of the N8900 features via the extensive menu system. You can either use the voltage and current knobs or enter your settings via the keypad. You can also set protection settings, power-on states, and other features. The output voltage, current, and power can be displayed simultaneously, and annunciators at the bottom of the display show power supply status and operating modes. You can lock the front panel controls to protect against accidental power-supply parameter changes.

Device protection

To safeguard your device, the N8900 Series power supplies provide over-temperature, over-current and over-voltage protection to shut down the power supply output when a fault condition occurs.

Simplify system connections

The N8900 Series power supplies comes standard with GPIB, Ethernet/LAN, USB 2.0, and analog interfaces giving you the flexibility to use your I/O interface of choice today and safeguard your test setup for the future. There is no need to worry whether or not you are choosing the right interface when they all come standard. The N8900 is fully compliant with the LXI Core specification.

Remote access and control

The built-in Web server provides remote access and control of the instrument via a standard browser. This control goes above and beyond the LXI specification, giving users the ability to monitor and control the instrument from anywhere. Using the Web browser, you can set up, monitor and operate the N8900 remotely.

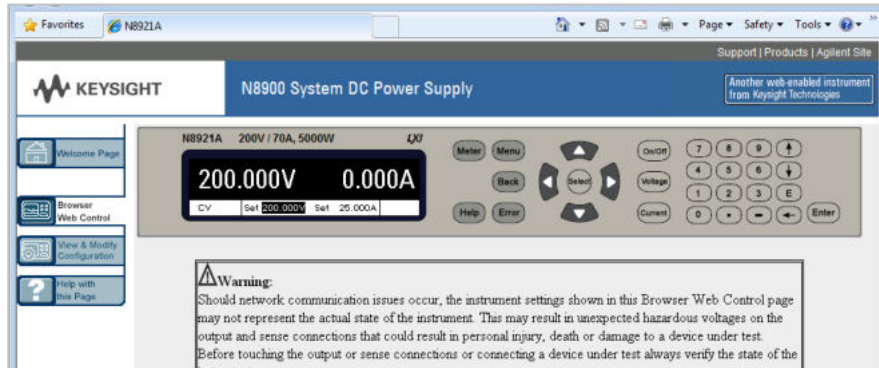

Figure 3. N8900 Series web graphical user interface for remote access and control of the power supply

Easy system integration and configuration

To simplify system development, the N8900 comes standard with IVI-COM drivers. The N8900 supports the easy-to-use SCPI (Standard Commands for Programmable Instruments).

Parallel operation for more power

Need more power, we've got you covered. Quickly create a primary/secondary setup for even more total output power. The N8900 Series power supplies give you the flexibility to easily connect in parallel up to ten identical units (same model number) for greater output current. The units can also be configured to look like "one" big power supply. (See Figure 4, page 4.) Series operation is not recommended.

Analog programming and monitoring

The output voltage and current can be programmed from zero to full-scale by an analog voltage signal from 0 to 5 V or 0 to 10 V. Each corresponding to 0 to 100% of full-scale. The measured output voltage and current can also be monitored in the same way.

AC input

The N8900 has 28 total models. Fourteen have 208 VAC inputs and the remaining 14 have 400 VAC inputs. This gives the N8900 the ability to be used anywhere in the world. Choose 208 VAC for regions such as the Americas and Japan or choose 400 VAC for regions such as Europe and Asia.

Performance specifications

All specifications pertain to >2% of rated voltage and >1% of rated current

	N8920A / N8940A	N8921A / N8941A	N8923A / N8943A	N8924A / N8944A	N8925A / N8945A	N8926A / N8946A	N8928A / N8948A	N8929A / N8949A	N8930A / N8950A	N8931A / N8951A	N8932A / N8952A	N8934A / N8954A	N8935A / N8955A	N8937A / N8957A
DC output ratings														
Voltage	80 V	200 V	500 V	750 V	80 V	200 V	500 V	750 V	1000 V	80 V	200 V	500 V	750 V	1500 V
Current	170 A	70 A	30 A	20A	340 A	140 A	60 A	40 A	30 A	510 A	210 A	90 A	60 A	30 A
Power	5 kW	5 kW	5 kW	5 kW	10 kW	10 kW	10 kW	10 kW	10 kW	15 kW	15 kW	15 kW	15 kW	15 kW
Output voltage ripple and noise														
CV p-p ¹	200 mV	375 mV / 300 mV	350 mV	800 mV	320 mV	375 mV / 300 mV	350 mV	800 mV	1600 mV	320 mV	375 mV / 300 mV	350 mV	800 mV	2400 mV
CV rms ²	16 mV	40 mV	70 mV	200 mV	25 mV	40 mV	70 mV	200 mV	350 mV	25 mV	40 mV	70 mV	200 mV	400 mV
Load effect (change from 0% to 100% of full load)														
Voltage	40 mV	100 mV	250 mV	375 mV	40 mV	100 mV	250 mV	375 mV	500 mV	40 mV	100 mV	250 mV	375 mV	750 mV
Current	255 mA	105 mA	45 mA	30 mA	510 mA	210 mA	90 mA	60 mA	53 mA / 45 mA	765 mA	315 mA	135 mA	90 mA	53 mA / 45 mA
Programming accuracy (23 °C ± 5 °C)														
Voltage	≤ 80 mV	≤ 200 mV	≤ 500 mV	≤ 750 mV	≤ 80 mV	≤ 200 mV	≤ 500 mV	≤ 750 mV	≤ 1.0 V	≤ 80 mV	≤ 200 mV	≤ 500 mV	≤ 750 mV	≤ 1.5 V
Current	≤ 340 mA	≤ 140 mA	≤ 60 mA	≤ 40 mA	≤ 680 mA	≤ 280 mA	≤ 120 mA	≤ 80 mA	≤ 60 mA	≤ 1.1 A	≤ 420 mA	≤ 180 mA	≤ 120 mA	≤ 60 mA
Measurement accuracy (23 °C ± 5 °C)														
Voltage	≤ 80 mV	≤ 200 mV	≤ 500 mV	≤ 750 mV	≤ 80 mV	≤ 200 mV	≤ 500 mV	≤ 750 mV	≤ 1.0 V	≤ 80 mV	≤ 200 mV	≤ 500 mV	≤ 750 mV	≤ 1.5 V
Current	≤ 340 mA	≤ 140 mA	≤ 60 mA	≤ 40 mA	≤ 680 mA	≤ 280 mA	≤ 120 mA	≤ 80 mA	≤ 60 mA	≤ 1.1 A	≤ 420 mA	≤ 180 mA	≤ 120 mA	≤ 60 mA
Load transient recovery time (time for output voltage to recover within 1% of its rated output for a load change from 10% to 90% of its rated output current)														
Time	≤ 1.5 ms													



Figure 4. Parallel operation for more power (cables not included)

1. 20 Hz to 20 MHz
2. 20 Hz to 300 kHz

Supplemental characteristics (typical)

	N8920A / N8940A	N8921A / N8941A	N8923A / N8943	N8924A / N8944A	N8925A / N8945A	N8926A / N8946A	N8928A / N8948A	N8929A / N8949A	N8930A / N8950A	N8931A / N8951A	N8932A / N8952A	N8934A / N8954A	N8935A / N8955A	N8937A / N8957A
Output response time: Time from 10% to 90%, or 90% to 10%, of total voltage excursion														
Up, full load ¹	≤ 30 ms													
Down, full load ¹	≤ 80 ms													
Down, no load	≤ 30 s	≤ 10 s	≤ 10 s	≤ 10 s	≤ 30 s	≤ 10 s	≤ 10 s	≤ 10 s	≤ 10 s	≤ 30 s	≤ 10 s	≤ 10 s	≤ 10 s	≤ 10 s
Command response time														
< 25 ms														
Remote sense compensation														
Volts/load lead	2 V	5 V	10 V	18 V	2 V	5 V	10 V	18 V	22 V	2 V	5 V	10 V	18 V	30 V
Over-voltage protection														
Range	0 - 88 V	0 - 220 V	0 - 550 V	0 - 825 V	0 - 88 V	0 - 220 V	0 - 550 V	0 - 825 V	0 - 1100 V	0 - 88 V	0 - 220 V	0 - 550 V	0 - 825 V	0 - 1650 V
Source effect (±10% of AC input rating)														
Voltage	16 mV	40 mV	100 mV	150 mV	16 mV	40 mV	100 mV	150 mV	200 mV	16 mV	40 mV	100 mV	150 mV	300 mV
Current	85 mA	35 mA	15 mA	10 mA	170 mA	70 mA	30 mA	20 mA	15 mA	255 mA	105 mA	45 mA	30 mA	15 mA
Output current ripple and noise														
CC rms	80 mA	22 mA	16 mA	16 mA	160 mA	44 mA	32 mA	32 mA	22 mA	240 mA	66 mA	48 mA	48 mA	26 mA
Programming resolution														
Voltage	4 mV	9 mV	21 mV	31 mV	4 mV	9 mV	21 mV	31 mV	41 mV	4 mV	9 mV	21 mV	31 mV	61 mV
Current	7 mA	3 mA	2 mA	1 mA	14 mA	6 mA	3 mA	2 mA	2 mA	21 mA	9 mA	4 mA	3 mA	2 mA
Measurement resolution														
Voltage	4 mV	9 mV	21 mV	31 mV	4 mV	9 mV	21 mV	31 mV	41 mV	4 mV	9 mV	21 mV	31 mV	61 mV
Current	7 mA	3 mA	2 mA	1 mA	14 mA	6 mA	3 mA	2 mA	2 mA	21 mA	9 mA	4 mA	3 mA	2 mA
Output terminal isolation														
Positive terminal	+400 V	+600 V	+1000 V	+1000 V	+400 V	+600 V	+1000 V	+1000 V	+1000 V	+400 V	+600 V	+1000 V	+1000 V	+1500 V
Negative terminal	±400 V	±400 V	±725 V	±725 V	±400 V	±400 V	±725 V	±725 V	±725 V	±400 V	±400 V	±725 V	±725 V	±1000 V
Acoustic noise declaration														
Idle fan speed	55 dBA / 48 dBA				55 dBA / 51 dBA					56 dBA / 52 dBA				
Max fan speed	76 dBA / 57 dBA				77 dBA / 62 dBA					79 dBA / 73 dBA				
208 VAC input (N8920A - N8937A)														
Nominal input voltage	208 VAC													
Input range	Nominal ±10%													
Frequency	45-65 Hz													
Phase	3 phase													
Input current	2 x 32 A				2 x 32 A, 1 x 56 A					3 x 56 A				
Inrush current	41 A				97 A					97 A				
Power factor	> 0.99													
Efficiency	87.5%	90%	91%	90%	87.5%	89.5%	91%	90%	91%	87.5%	89.5%	91%	90%	91%
400 VAC input (N8940A - N8957A)														
Nominal input voltage	400 VAC													
Input range	Nominal ±10%													
Frequency	45-65 Hz													
Phase	3 phase													
Input current	2 x 16 A				2 x 16 A, 1 x 28 A					3 x 28 A				
Inrush current	28A				49A					49A				
Power factor	> 0.99													
Efficiency	91.5%	91.5%	93.5%	90%	89.5%	91.5%	91%	90%	93.5%	89.5%	91.5%	93.5%	90%	93%

1. For purposes of output response time, full load occurs at the full range output voltage and the maximum output current available at the full output voltage.

Supplemental characteristics (typical) - all models

Supplemental characteristics	
Analog programming:	
Input range	Selectable: 0 to 5 V or 0 to 10 V
Accuracy	Specified accuracy + 0.2% of rating
Input impedance	150 k Ω
Referenced to:	Ground
Temperature coefficients: (after 30 minute warmup)	
Voltage	50 PPM/ $^{\circ}$ C of rated output voltage
Current	50 PPM/ $^{\circ}$ C of rated output current
Series operation not recommended	
Parallel operation	
Primary/secondary	Yes
Savable states	
Nonvolatile memory	10
Interface capabilities	
GPIB, USB 2.0, 10/100 LAN	SCPI - 1993, IEEE 488.2 compliant interface; Requires Keysight I/O Libraries 16.3 or later
LXI compliance	LXI Core 2011 compliant
Environmental conditions	
Environment	Indoor use, installation category II (AC input), pollution degree 2
Operating temp	0 $^{\circ}$ C to 45 $^{\circ}$ C
Storage temp	-20 $^{\circ}$ C to 70 $^{\circ}$ C
Operating humidity	80%
Storage humidity	80%
Altitude	2000 m
Built-in Web server	Requires Internet Explorer 7+, Firefox, or Chrome. Additionally requires Java plug-in and the Java Runtime Environment.
Regulatory compliance	
EMC	<ul style="list-style-type: none"> - Complies with European EMC Directive for test and measurement products - Complies with Australian standard and carries C-Tick mark - Complies with Canadian ICES-001
Safety	<ul style="list-style-type: none"> - Complies with European Low Voltage Director and carries the CE-marking - Complies with US and Canadian safety regulations - Not applicable for IT mains supply systems
<p>Declarations of Conformity for this product may be downloaded from the web. Go to www.keysight.com/go/conformity and click on "Declarations of Conformity".</p>	

Outline diagrams

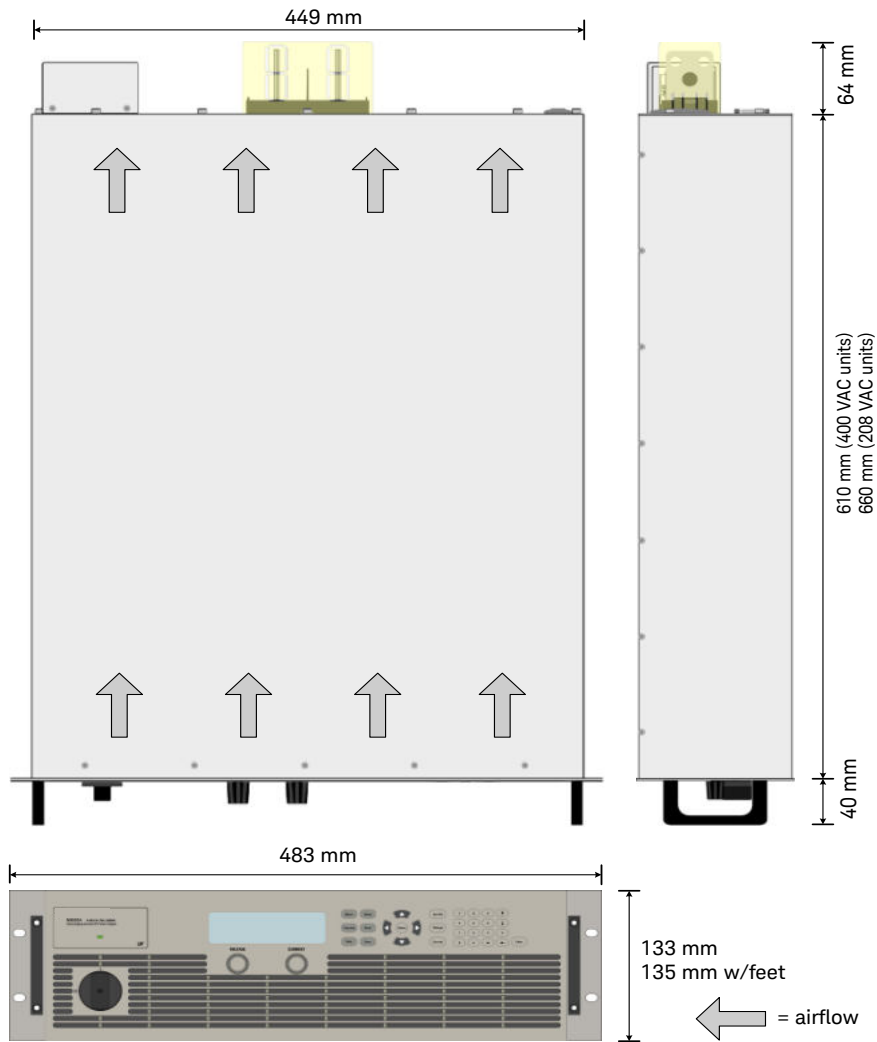

Product Weight

208 VAC models

5 kW models: 18.5 kg (40.6 lbs)

10 kW models: 26.8 kg (59 lbs)

15 kW models: 35.2 kg (77.4 lbs)

400 VAC models

5 kW models: 16.9 kg (37.2 lbs)

10 kW models: 24.3 kg (53.5 lbs)

15 kW models: 31.8 kg (70 lbs)

DC Output Bus-Bar Detail

80 V and 200 V models

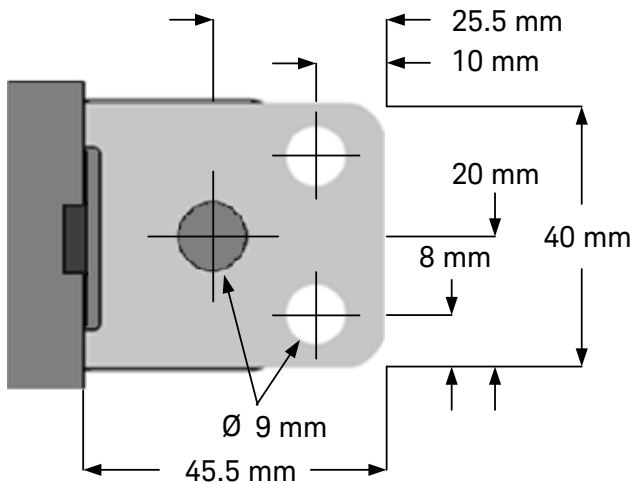

≥ 500 V models

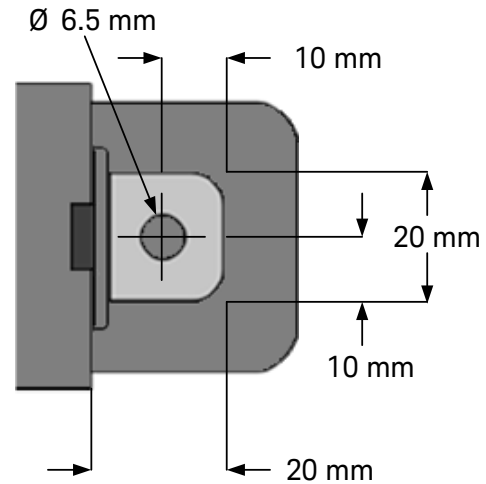

Available models

Model #	Max voltage (V)	Current (A) @ max voltage ¹	Voltage (V) @ max current ¹	Max current (A)	Max power (W)	AC input voltage (VAC)
N8920A	80	62.5	29.4	170	5000	208
N8921A	200	25.0	71.4	70	5000	208
N8923A	500	10.0	166.7	30	5000	208
N8924A	750	6.7	250.0	20	5000	208
N8925A	80	125.0	29.4	340	10000	208
N8926A	200	50.0	71.4	140	10000	208
N8928A	500	20.0	166.7	60	10000	208
N8929A	750	13.3	250.0	40	10000	208
N8930A	1000	10.0	333.3	30	10000	208
N8931A	80	187.5	29.4	510	15000	208
N8932A	200	75.0	71.4	210	15000	208
N8934A	500	30.0	166.7	90	15000	208
N8935A	750	20.0	250.0	60	15000	208
N8937A	1500	10.0	500.0	30	15000	208
N8940A	80	62.5	29.4	170	5000	400
N8941A	200	25.0	71.4	70	5000	400
N8943A	500	10.0	166.7	30	5000	400
N8944A	750	6.7	250.0	20	5000	400
N8945A	80	125.0	29.4	340	10000	400
N8946A	200	50.0	71.4	140	10000	400
N8948A	500	20.0	166.7	60	10000	400
N8949A	750	13.3	250.0	40	10000	400
N8950A	1000	10.0	333.3	30	10000	400
N8951A	80	187.5	29.4	510	15000	400
N8952A	200	75.0	71.4	210	15000	400
N8954A	500	30.0	166.7	90	15000	400
N8955A	750	20.0	250.0	60	15000	400
N8957A	1500	10.0	500.0	30	15000	400



Figure 5. N8924A autoranging system DC power supply

1. The N8900 Series are autoranging power supplies. The “Current @ Max Voltage” and “Voltage @ Max Current” are listed to show the full range of voltage and current combinations possible due to the autoranging capability.

Options

None

AC input voltages

If the AC input voltage where the power supply will be used is:

- 187 to 229, please choose a 208 VAC model (N8920A-N8937A)
- 360 to 440 VAC, please choose a 400 VAC model (N8940A-N8957A)

Accessories

N8958A Rack mount kit for Keysight racks
Use standard rack rails for non-Keysight racks.

Line cords and terminations (plugs)

Due to the number of different line cords and terminations around the world, the N8900 power supplies do not come with line cords or terminations. Users will need to supply their own dependent on the local laws and codes of the country/region where the power supply will be used.

Learn more at: www.keysight.com

For more information on Keysight Technologies' products, applications or services, please contact your local Keysight office. The complete list is available at: www.keysight.com/find/contactus

