

# RP5900 Series Regenerative DC Power Supplies

RP5913A, RP5915A, RP5916A (2 kW)

RP5923A, RP5925A, RP5926A (4 kW)

RP5933A, RP5935A, RP5936A (6 kW)

RP5943A, RP5945A, RP5946A (12 kW)

## High-Power, High-Density Regenerative DC Power Supplies with Integrated Electronic Load

Introducing the Keysight RP5900 Series of midrange, bidirectional DC power supplies with integrated electronic load capability. These single-output, programmable power supplies are available in compact 1U and 2U sizes, with output power ranging from 2 kW to 12 kW. With regenerative capabilities, they efficiently return the energy they consume to the grid, reducing energy costs and minimizing cooling needs. The integrated electronic load capability also contributes to cost and space savings and reduces integration time that would otherwise be necessary.

The RP5900 Series is equipped with system-ready features, including multiple I/O interfaces, built-in voltage and current measurements, and output voltage (80 V to 800 V) and current (8 A to 240 A), accelerating the testing of your power products, whether in the lab or on the production floor.

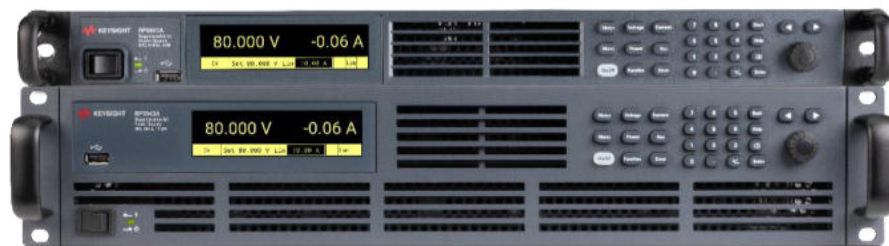

# Table of Contents

- Introduction.....3
- Our Solution .....3
- Specifications – RP591xA, 2 kW Models..... 12
- Supplemental Characteristics – RP591x, 2 kW ..... 13
- Specifications – RP592x, 4 kW Models ..... 14
- Supplemental Characteristics – RP592x, 4 kW..... 15
- Specifications – RP593x, 6 kW Models ..... 16
- Supplemental Characteristics – RP593x, 6 kW..... 17
- Specifications – RP594x, 12 kW Models ..... 18
- Supplemental Characteristics – RP594x, 12 kW ..... 19
- Common Characteristics – All Models .....20
- Output Quadrants .....22
- Outline Diagrams – 1U Models.....23
- Outline Diagrams – 2U Models ..... 24
- Ordering Information .....25
- Keysight Support Services .....26
- Definitions .....28

# Introduction

In the global marketplace, demand for midrange power solutions to address the power requirements of today's innovative higher power devices is increasing. While initial capital investments often command attention, operating expenses can play an even more critical role in the total cost of ownership. Effectively managing that cost can give your business a significant competitive advantage.

A reliable midrange power solution with the right features and a low cost of ownership can minimize your high-power test costs by reducing floor space requirements, cutting heat dissipation, and maximizing uptime. The Keysight RP5900 Series regenerative power supply delivers these benefits, helping you improve efficiency while keeping costs under control.

## Our Solution

The Keysight RP5900 Series is a family of bidirectional, regenerative DC power supplies with an integrated regenerative electronic load. Its regenerative design returns energy to the grid cleanly, reducing energy consumption and cooling costs. Available in compact 1U-high and 2U-high options, the RP5900 Series helps cut energy costs, floor space requirements, and integration time. It delivers trusted performance with flexible features in a single, space-efficient solution.

The RP5900 Series enables you to do the following:

- Deliver a complete regenerative load and power system for versatile testing needs.
- Provide voltage options of 80 V, 500 V, and 800 V, with current up to  $\pm 240$  A for broad application coverage.
- Offer a wide 2,000 W to 12,000 W power range to match small-scale to high-power test requirements.
- Operate seamlessly in two-quadrant mode to function as both a power source and regenerative load.
- Maximize rack efficiency with industry-leading compact 1U or 2U designs.
- Save valuable rack space with stackable parallel connections, up to 16 units
- Cut operational costs by regenerating power back to the grid.
- Accelerate battery testing with a built-in waveform generation function.
- Connect easily with a full suite of industrial interfaces: GPIB, USB, LAN, CAN, analog, and RS-232.
- Gain deeper insights with Keysight PathWave Advanced Power Suite, integrated for power analysis and battery emulation / profiling tools.

## Reduce Costs for Cooling and Electricity with an Eco-Friendly Regenerative Design

The RP5900 returns 95% of the energy consumed to the grid cleanly, saving costs from energy consumption and cooling while not interfering with grid performance. When sinking current, the RP5900 automatically returns excess power to the grid, with no programming required. To safeguard your device under test (DUT), the RP5900 automatically senses that the grid is live, detects phase voltage and frequency in real time, and synchronizes safely before regenerating power to the grid.

With efficiency of more than 85%, the RP5900 lowers electricity use when sourcing or sinking and reduces heat dissipation when sinking, cutting air conditioning requirements. Additionally, these efficiencies reduce carbon emissions and their environmental impact.

## Bidirectional Source and Independent Electronic Load

The RP5900 can continuously sink up to 100% of its rated current. It offers both a bidirectional power supply and an independent regenerative electronic load in a single unit. The two-quadrant, bidirectional sourcing and sinking capability of the DC power supply allows for seamless switching between sourcing and sinking current.

## Autoranging Output Does the Job of Multiple Power Supplies

The RP5900 power supply features an autoranging output that expands the power curve, providing more voltage and current combinations from a single unit. Unlike power supplies with rectangular output characteristics, which deliver full power at only one voltage-current point, the RP5900 adapts across a wide range. It is like having many rectangular power supplies in one.

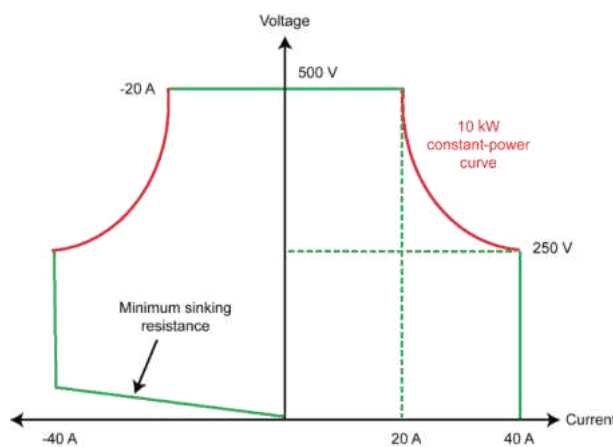

**Figure 1.** Autoranging output characteristic of the 12 kW RP5946A

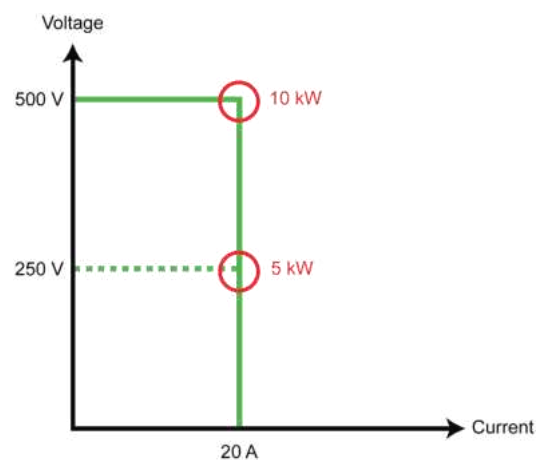

**Figure 2.** Rectangular output characteristic of a conventional 10 kW supply

## Emulate a High-Power Battery from the Front Panel

With its battery emulation feature, the RP5900 Series enables you to test your devices under realistic power conditions. Emulating the battery is essential when characterizing battery operating life and detecting early product failures. The RP5900's bidirectional design and variable output impedance make it easy for users to set voltage, capacity, internal resistance, and State of Charge (SOC) to define battery characteristics quickly from the front panel, and to simulate the charge and discharge characteristics of a battery.

## Accurately Characterize Your DUT's Power Profile with Advanced Measurements

The RP5900 provides simultaneous voltage and current measurement capabilities. You can measure using two main modes: averaged or digitized. In average mode, the RP5900 delivers accurate voltage and current measurements. The digitizing capability allows you to select the type of measurement returned and fine-tune the measurement quality.

In addition to voltage and current measurement capabilities, the RP5900 Series regenerative power system offers built-in power, amp-hour, and watt-hour calculations. These measurements simplify your power efficiency and storage calculations.

## Avoid Damage to Your DUT

When testing costly DUTs, integrating power protection measures into the test system is critical. Instruments with built-in or integrated protection respond faster than software-based safeguards, detecting and addressing error conditions quickly to reduce the risk of serious damage. The RP5900 provides built-in overvoltage, overcurrent, overpower, and undervoltage protection to help safeguard your DUT.

## Generate Voltage and Current Transients

DUTs operating in rugged environments, such as automotive electronics and avionics, can often experience transient behavior from the power source, such as voltage dropouts or surges. To ensure your DUT stands up to these real-world transients, you must simulate worst-case power transient conditions during testing. The RP5900 provides three functions for simulating either voltage or current transients for testing:

- **Step:** A one-time event steps the output voltage or current up or down in response to a triggered event.
- **Constant dwell arbitrary waveforms:** An arbitrary waveform generator (ARB) allows you to generate complex user-defined voltage or current waveforms of up to 65,535 data points. One dwell setting applies for the entire ARB, from 1 ms to 3,600 s.
- **List:** A list can consist of up to 200 steps, each with a unique dwell time, which specifies how many seconds the list will remain at that step before advancing. Lists can also be trigger-paced, advancing one step for each trigger received.

## Properly Powering Your DUT On and Off

If you work with DUTs with multiple power supply inputs, you often need to sequence on or off for each power supply at precise, repeatable times to prevent current surges and latch-up conditions. In addition, you may need to control the ramp rate of each supply at turn-on or turn-off. These requirements add significant hardware and software complexity to an automated test equipment system. The RP5900 simplifies this process with built-in sequencing across multiple supplies, providing a clean, low-complexity way to properly power on or off your DUT during testing.

## Multiple Operating Modes

The RP5900 Series provides voltage priority mode (CV), current priority mode (CC), resistance priority mode (CR), and power priority mode (CP) under the Load mode:

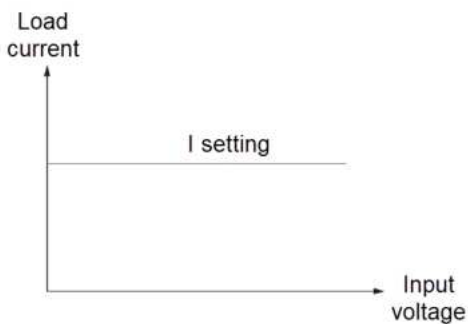

Current Priority (CC mode)

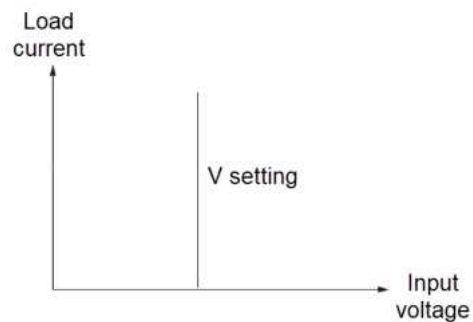

Voltage Priority (CV mode)

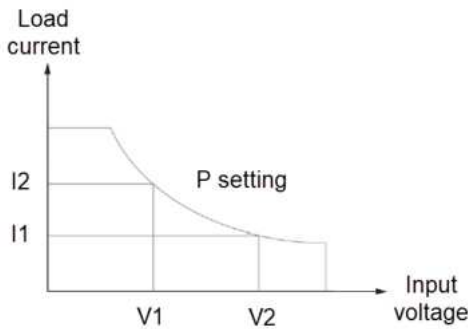

Power Priority (CP mode)

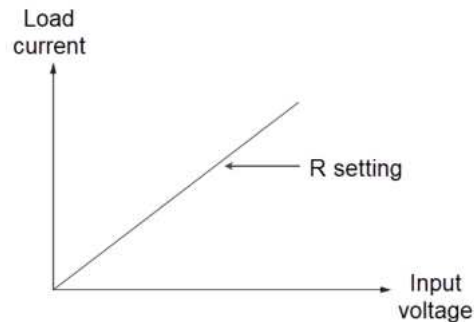

Resistance Priority (CR mode)

The RP5900 Series also has four complex modes under the Load mode operation:

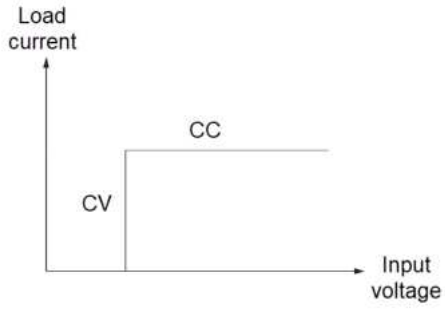

**CV+CC mode**

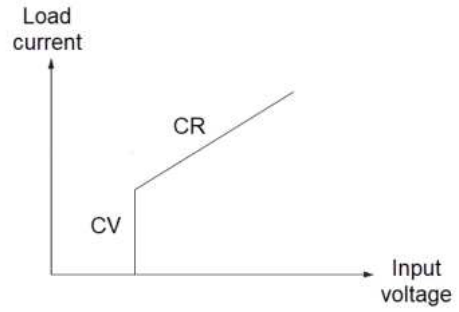

**CV+CR mode**

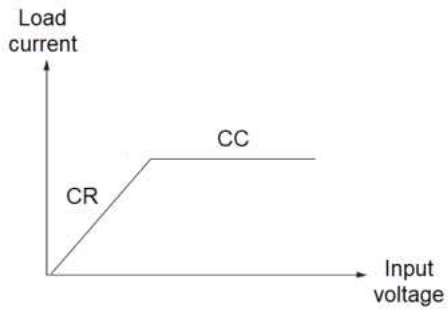

**CC+CR mode**

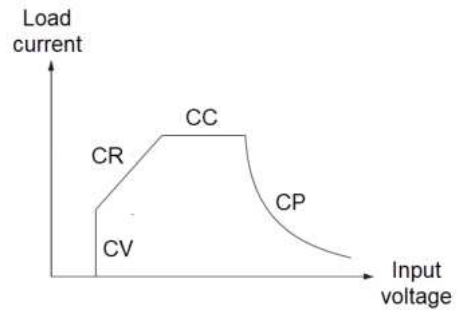

**CC+CV+CP+CR mode (AUTO)**

## Add Power Flexibility to Your Test System by Paralleling Multiple Power Supplies

Paralleling multiple power supplies together is a great way to add power flexibility to your test system. Conventional power supplies often cannot maintain the desired Constant Voltage (CV) or Constant Current (CC) mode when paralleled. For instance, when trying to operate in CV mode with two parallel supplies, one will typically source the bulk of the current and operate in CC mode, and the other supply will source only a fraction of the current and operate in CV mode. This imbalance can significantly degrade certain power supply performance specifications, such as transient response. The RP5900 eliminates this issue with a built-in paralleling capability to ensure that each supply equally shares the load current, so they all remain in the desired mode — CV or CC.

The RP5900 also supports primary / secondary mode, which enables you to configure and program the paralleled units as a single supply of up to 192 kW of total power; there is no need to program each supply individually. The RP5900 Series regenerative power system gives you the flexibility to easily parallel up to 16 units for greater output current. Parallel connection of mixed models with identical voltage rating is only applicable for 6kW and 12kW models with the same firmware version. All other models require the same models of the same firmware to be paralleled.



**Figure 3.** Parallel operation for more power

## Simplify System Connection

The RP5900 Series power supplies come standard with Ethernet / LAN, USB 2.0, CAN IO interfaces, and optional GPIB, analog, and RS-232 IO interfaces, giving you the flexibility to use your I/O interface of choice today and safeguard your test setup for the future. The RP5900 is compliant with 1.5 LXI Device Specification 2016 and includes a built-in web interface. This enables you to control the RP5900 remotely using a web browser via a LAN connection.

## AC Input

The RP5900 Series has a fully bidirectional three-phase AC input inverter, which allows for seamless bidirectional power flow between AC mains and DC output terminals. The nominal AC input range and frequency are 200 to 520 VAC, 50 / 60 Hz for 2 kW and 4 kW models.

The 6 kW and 12 kW models will require 380 to 480 VAC and 50 / 60 Hz to achieve maximum rated current and power. You can operate these models at 200VAC to 208VAC, with the condition that the current and power ratings are reduced by ~35%.

The RP5900 uses a three-phase AC input with AC mains connections: L1, L2, L3, PE.

## Digital Control Port

The rear panel of every RP5900 power supply features a digital control port containing seven user-configurable I/O pins that provide access to various control functions. Each pin is user-configurable. Table 1 describes the possible pin configuration for the digital port functions.

<u>Pin function</u>	<u>Available configuration pins</u>
Digital I/O and digital in	Pins 1 through 7
Protection status	Pins 2
External trigger in / out	Pin 4
Inhibit in	Pins 5
Output couple	Pins 6 and 7
Common (connected to ground)	Pins 8



**Figure 4.** Digital control port on the rear panel

## Rack-Mount Kits

You can easily rack mount the RP5900 Series (EL4900 DC loads RP5900 supplies) using the following kits:

- RP5904C for 1U models
- RP5905C for 2U models

# PW9252A PathWave Advanced Power Control and Analysis Application

The PW9252A PathWave Advanced Power Control and Analysis application provides fast and easy access to the sourcing and measurement functionality of your RP5900 Series regenerative power supply without any programming. PW9252A allows flexibility on the number of instrument connections by just purchasing the number of licenses based on the number of connecting instruments. They are flexible tools for any application and allow you to control any RP5900 Series model via LAN, GPIB, and USB interface. The software can also control other Keysight power supplies, including the popular N6700 modules, the N6705 DC power analyzer, N7900 advanced power supplies, and the RP7900 regenerative power systems.

PW9252A enables you to do the following:

- Control and analyze up to 10 RP5900 Series systems simultaneously.
- Create complex waveforms effortlessly, enter formulas, choose from built-in patterns, or import your data, for precise DUT stimulation or load simulation.
- Enhance productivity with intuitive PC-style controls and a large, easy-to-read display.
- Log measurement data directly to your PC for fast storage, review, and reporting.
- Perform detailed CCDF statistical analysis to gain deeper insights into power-consumption patterns.
- Integrate seamlessly into your existing programming environment using the API for complete automation flexibility.



Figure 5. PW9252A interface with 4 channels connected

# PW9253A PathWave Advanced Battery Test and Emulation Application

The Keysight PW9253A PathWave Advanced Battery Test and Emulation application provides a test environment for running battery tests, generating battery models, and performing battery emulation using one or more Keysight two-quadrant power supplies. Its emulation function enables you to quickly output the desired battery operation conditions, covering various test scenarios without waiting for a real battery to charge or discharge to a specific condition. The software also offers flexibility. Just purchase the number of licenses you need based on the number of connected instruments. The software controls other Keysight power supplies, including the popular N6700 modules, the N6705 DC power analyzer, N7900 advanced power supplies, and the RP7900 regenerative power system.

The PW9253A enables you to do the following:

- Test and emulate batteries up to 600 kW and up to 2,000 V, depending on the maximum rating of the instrument.
- Choose from four modes of operation: emulation, profiler, discharge / charge, and cyclers.
- Create custom battery models.
- Use API functions to facilitate integration into your programming environment.
- Provides advanced control capabilities — capacity rating, state of charge, constant or dynamic level selection, pulse width control.
- Accurately capture voltage, current, and capacity from seconds to days.
- Create custom dynamic loading characteristics for discharging.
- Import battery models.

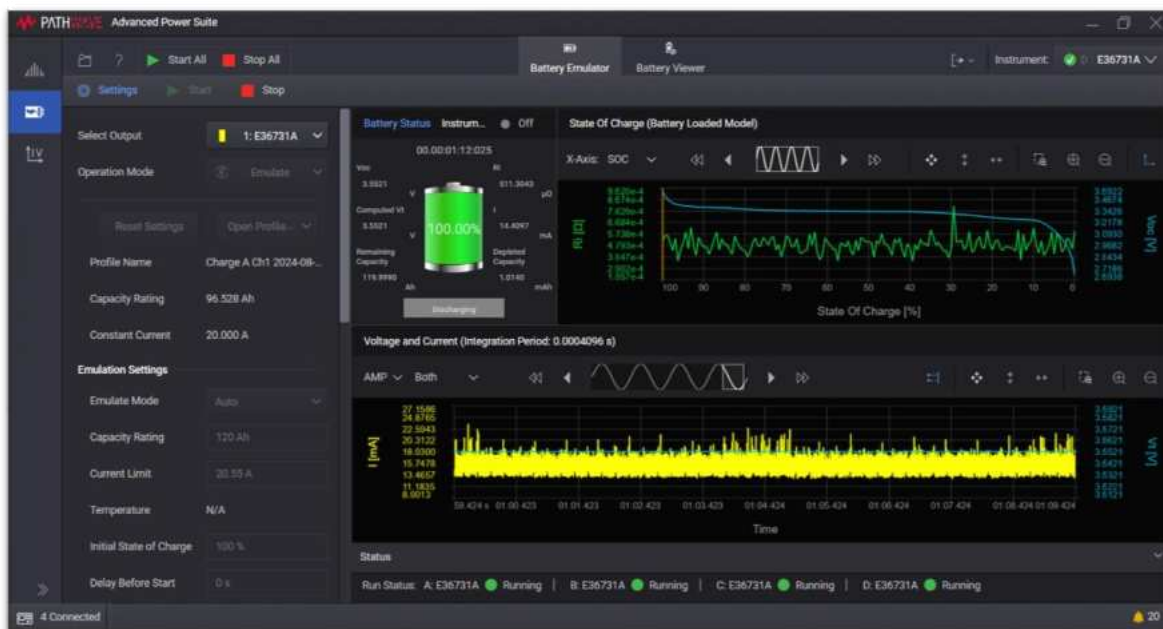

Figure 6. PW9253A connected to a two-quadrant power supply

# Specifications – RP591xA, 2 kW Models

Unless otherwise noted, specifications are warranted over the ambient temperature range of 0 to 40 °C after a 30-minute warm-up period. Specifications apply at the output terminals, with the sense terminals connected to the output (local sensing) terminals.

Refer to the Keysight RP5900 Series documentation for the setup conditions for all performance specifications.

For more detailed specifications, refer to the [RP5900 Series user manual](#).

	RP5913A		RP5915A		RP5916A	
Specification	Source	Load	Source	Load	Source	Load
<b>DC Ratings</b>						
Voltage	0 to 80 V	0 to 80 V	0 to 500 V	0 to 500 V	0 to 800 V	0 to 800 V
Current	0 to ± 40 A	0 to 40 A	0 to ± 12 A	0 to 12 A	0 to ± 8 A	0 to 8 A
Power	0 to ± 2 kW	0 to 2 kW	0 to ± 2 kW	0 to 2 kW	0 to ± 2 kW	0 to 2 kW
<b>Output Ripple and Noise<sup>3</sup></b>						
CV peak-to-peak <sup>1</sup>	≤ 200 mVp-p	-	≤ 1,500 mVp-p	-	≤ 2,400 mVp-p	-
CV rms <sup>2</sup>	≤ 80 mVrms	-	≤ 300 mVrms	-	≤ 800 mVrms	-
<b>Load Effect (Load Regulation)<sup>3</sup></b>						
Voltage	16 mV	16 mV	100 mV	100 mV	160 mV	160 mV
Current	40 mA	40 mA	12 mA	12 mA	8 mA	8 mA
<b>Programming Accuracy<sup>3</sup></b>						
Voltage	0.03% + 24 mV		0.03% + 150 mV		0.03% + 240 mV	
Current	0.1% + 40 mA		0.1% + 12 mA		0.1% + 8 mA	
Power	0.5% + 10 W		0.5% + 10 W		0.5% + 10 W	
<b>Measurement Accuracy<sup>3</sup></b>						
Voltage	0.03% + 24 mV		0.03% + 150 mV		0.03% + 240 mV	
Current	0.1% + 60 mA		0.1% + 12 mA		0.1% + 8 mA	
Power	0.5% + 10 W		0.5% + 10 W		0.5% + 10 W	
<b>Load Transient Recovery Time<sup>3,4</sup></b>						
Recovery time	≤ 1 ms	-	≤ 1 ms	-	≤ 1 ms	-
Settling band	0.8 V	-	5 V	-	8 V	-

1. From 20 Hz to 20 MHz (-3 dB bandwidth) with resistive load, terminals ungrounded, or either terminal grounded.
2. From 20 Hz to 10 MHz (-3 dB bandwidth) with resistive load up to 400V, terminals ungrounded, or either terminal grounded.
3. Percent of value + offset; at 23 °C ± 5 °C after a 30-minute warm-up; measurement NPLC=1; valid for 1 year.
4. Time to recover to within the settling band following a step change from 25% to 90% of full load

# Supplemental Characteristics – RP591x, 2 kW

Supplemental characteristics are not warranted but are descriptions of performance determined by design or type testing. All supplemental characteristics are typical unless otherwise noted.

Characteristic	RP5913A		RP5915A		RP5916A	
	Source	Load	Source	Load	Source	Load
<b>Voltage Programming</b>						
Range	0 to 80 V		0 to 500 V		0 to 800 V	
Resolution	1 mV		10 mV		10 mV	
<b>Current Programming</b>						
Range	-40 to 40 A	0 to 40 A	-12 to 12 A	0 to 12 A	-8 to 8 A	0 to 8 A
Resolution	10 mA	10 mA	1 mA	1 mA	1 mA	1 mA
<b>Resistance Programming</b>						
Series resistance range	0 to 0.3 $\Omega$	-	0 to 1 $\Omega$	-	0 to 1 $\Omega$	-
Load resistance range	0.03 to 2,400 $\Omega$		0.3 to 15,000 $\Omega$		0.45 to 22,500 $\Omega$	
Resolution	1 m $\Omega$		10 m $\Omega$		10 m $\Omega$	
Accuracy	3 m $\Omega$		10 m $\Omega$		10 m $\Omega$	
<b>Voltage Programming Speed, No Load</b>						
Rise / fall time 10% to 90% of step	15 ms / 30ms	-	30 ms / 30ms	-	30 ms / 30ms	-
<b>Voltage Programming Speed, Full Load</b>						
Rise / fall time 10% to 90% of step	30 ms / 15 ms	-	60 ms / 30 ms	-	60 ms / 30 ms	-
<b>Source Effect (Line Regulation)</b>						
Voltage	$\leq 16$ mV	$\leq 16$ mV	$\leq 100$ mV	$\leq 100$ mV	$\leq 160$ mV	$\leq 160$ mV
Current	$\leq 24$ mA	$\leq 24$ mA	$\leq 7.2$ mA	$\leq 7.2$ mA	$\leq 4.8$ mA	$\leq 4.8$ mA
<b>Protection Capability</b>						
Overvoltage	82 V	85 V	505 V	530 V	808 V	835 V
Overcurrent	$\pm 42$ A	42 A	$\pm 12.5$ A	12.5 A	$\pm 8.4$ A	8.4 A
Overpower	$\pm 2,040$ W	2,040 W	$\pm 2,040$ W	2,040 W	$\pm 2,040$ W	2,040 W

# Specifications – RP592x, 4 kW Models

Unless otherwise noted, specifications are warranted over the ambient temperature range of 0 to 40 °C after a 30-minute warm-up period. Specifications apply at the output terminals, with the sense terminals connected to the output (local sensing) terminals.

Refer to the Keysight RP5900 Series documentation for the setup conditions for all performance specifications.

Supplemental characteristics are not warranted but are descriptions of performance determined by design or type testing. All supplemental characteristics are typical unless otherwise noted.

For more detailed specifications, refer to the [RP5900 Series user manual](#).

	RP5923A		RP5925A		RP5926A	
Specification	Source	Load	Source	Load	Source	Load
<b>DC Ratings</b>						
Voltage	0 to 80 V	0 to 80 V	0 to 500 V	0 to 500 V	0 to 800 V	0 to 800 V
Current	0 to ± 80 A	0 to 80 A	0 to ± 24 A	0 to 24 A	0 to ± 16 A	0 to 16 A
Power <sup>5</sup>	0 to ± 4 kW	0 to 4 kW	0 to ± 4 kW	0 to 4 kW	0 to ± 4 kW	0 to 4 kW
<b>Output Ripple and Noise <sup>3</sup></b>						
CV peak-to-peak <sup>1</sup>	≤ 200 mVp-p	-	≤ 1,000 mVp-p	-	≤ 1,600 mVp-p	-
CV rms <sup>2</sup>	≤ 80 mVrms	-	≤ 150 mVrms	-	≤ 300 mVrms	-
<b>Load Effect (Load Regulation) <sup>3</sup></b>						
Voltage	16 mV	16 mV	100 mV	100 mV	160 mV	160 mV
Current	80 mA	80 mA	24 mA	24 mA	16 mA	16 mA
<b>Programming Accuracy <sup>3</sup></b>						
Voltage	0.03% + 24 mV		0.03% + 150 mV		0.03% + 240 mV	
Current	0.1% + 80 mA		0.1% + 24 mA		0.1% + 16 mA	
Power	0.5% + 20 W		0.5% + 20 W		0.5% + 20 W	
<b>Measurement Accuracy <sup>3</sup></b>						
Voltage	0.03% + 24 mV		0.03% + 150 mV		0.03% + 240 mV	
Current	0.1% + 120 mA		0.1% + 24 mA		0.1% + 16 mA	
Power	0.5% + 20 W		0.5% + 20 W		0.5% + 20 W	
<b>Load Transient Recovery Time <sup>3,4</sup></b>						
Recovery time	≤ 1 ms	-	≤ 1 ms	-	≤ 1 ms	-
Settling band	0.8 V	-	5 V	-	8 V	-

1. From 20 Hz to 20 MHz (-3 dB bandwidth) with resistive load, terminals ungrounded, or either terminal grounded.
2. From 20 Hz to 10 MHz (-3 dB bandwidth) with resistive load up to 400V, terminals ungrounded, or either terminal grounded.
3. Percent of value + offset; at 23 °C ± 5 °C after a 30-minute warm-up; measurement NPLC=1; valid for 1 year.
4. Time to recover to within the settling band following a step change from 25% to 90% of full load.
5. The maximum power will be capped at 3897W when the three-phase input AC voltage (V) is 200VAC.

# Supplemental Characteristics – RP592x, 4 kW

Supplemental characteristics are not warranted but are descriptions of performance determined by design or type testing. All supplemental characteristics are typical unless otherwise noted.

Characteristic	RP5923A		RP5925A		RP5926A	
	Source	Load	Source	Load	Source	Load
<b>Voltage Programming</b>						
Range	0 to 80 V		0 to 500 V		0 to 800 V	
Resolution	1 mV		10 mV		10 mV	
<b>Current Programming</b>						
Range	-80 to 80 A	0 to 80 A	-24 to 24 A	0 to 24 A	-16 to 16 A	0 to 16 A
Resolution	10 mA	10 mA	1 mA	1 mA	1 mA	1 mA
<b>Resistance Programming</b>						
Series resistance range	0 to 0.3 $\Omega$	-	0 to 1 $\Omega$	-	0 to 1 $\Omega$	-
Load resistance range	0.015 to 1,200 $\Omega$		0.15 to 7,500 $\Omega$		0.22 to 11,250 $\Omega$	
Resolution	1 m $\Omega$		10 m $\Omega$		10 m $\Omega$	
Accuracy	3 m $\Omega$		10 m $\Omega$		10 m $\Omega$	
<b>Voltage Programming Speed, No Load</b>						
Rise / fall time 10% to 90% of step	15 ms / 30ms	-	30 ms / 30ms	-	30 ms / 30ms	-
<b>Voltage Programming Speed, Full Load</b>						
Rise / fall time 10% to 90% of step	30 ms / 15 ms	-	60 ms / 30 ms	-	60 ms / 30 ms	-
<b>Source effect (Line Regulation)</b>						
Voltage	$\leq 16$ mV	$\leq 16$ mV	$\leq 100$ mV	$\leq 100$ mV	$\leq 160$ mV	$\leq 160$ mV
Current	$\leq 48$ mA	$\leq 48$ mA	$\leq 14.4$ mA	$\leq 14.4$ mA	$\leq 9.6$ mA	$\leq 9.6$ mA
<b>Protection Capability</b>						
Overvoltage	82 V	85 V	505 V	530 V	808 V	835 V
Overcurrent	$\pm 84$ A	84 A	$\pm 25$ A	25 A	$\pm 16.8$ A	16.8 A
Overpower	$\pm 4,080$ W	4,080 W	$\pm 4,080$ W	4,080 W	$\pm 4,080$ W	4,080 W

# Specifications – RP593x, 6 kW Models

Unless otherwise noted, specifications are warranted over the ambient temperature range of 0 to 40 °C after a 30-minute warm-up period. Specifications apply at the output terminals, with the sense terminals connected to the output (local sensing) terminals.

Refer to the Keysight RP5900 Series documentation for the setup conditions for all performance specifications.

Supplemental characteristics are not warranted but are descriptions of performance determined by design or type testing. All supplemental characteristics are typical unless otherwise noted.

For more detailed specifications, refer to the [RP5900 Series user manual](#).

	RP5933A		RP5935A		RP5936A	
Specification	Source	Load	Source	Load	Source	Load
<b>DC Ratings</b>						
Voltage	0 to 80 V	0 to 80 V	0 to 500 V	0 to 500 V	0 to 800 V	0 to 800 V
Current	0 to ± 120 A	0 to 120 A	0 to ± 36 A	0 to 36 A	0 to ± 24 A	0 to 24 A
Power	0 to ± 6 kW	0 to 6 kW	0 to ± 6 kW	0 to 6 kW	0 to ± 6 kW	0 to 6 kW
<b>Output Ripple and Noise <sup>3</sup></b>						
CV peak-to-peak <sup>1</sup>	≤ 200 mVp-p	-	≤ 500 mVp-p	-	≤ 1,000 mVp-p	-
CV rms <sup>2</sup>	≤ 80 mVrms	-	≤ 100 mVrms	-	≤ 160 mVrms	-
<b>Load Effect (Load Regulation) <sup>3</sup></b>						
Voltage	16 mV	16 mV	100 mV	100 mV	160 mV	160 mV
Current	120 mA	1200 mA	36 mA	36 mA	32 mA	32 mA
<b>Programming Accuracy <sup>3</sup></b>						
Voltage	0.03% + 24 mV		0.03% + 150 mV		0.03% + 240 mV	
Current	0.1% + 120 mA		0.1% + 36 mA		0.1% + 24 mA	
Power	0.5% + 30 W		0.5% + 30 W		0.5% + 30 W	
<b>Measurement Accuracy <sup>3</sup></b>						
Voltage	0.03% + 24 mV		0.03% + 150 mV		0.03% + 240 mV	
Current	0.1% + 200 mA		0.1% + 36 mA		0.1% + 24 mA	
Power	0.5% + 30 W		0.5% + 30 W		0.5% + 30 W	
<b>Load Transient Recovery Time <sup>3,4</sup></b>						
Recovery time	≤ 1 ms	-	≤ 1 ms	-	≤ 1 ms	-
Settling band	0.8 V	-	5 V	-	8 V	-

1. From 20 Hz to 20 MHz (-3 dB bandwidth) with resistive load, terminals ungrounded, or either terminal grounded.
2. From 20 Hz to 10 MHz (-3 dB bandwidth) with resistive load up to 400V, terminals ungrounded, or either terminal grounded.
3. Percent of value + offset; at 23 °C ± 5 °C after a 30-minute warm-up; measurement NPLC=1; valid for 1 year.
4. Time to recover to within the settling band following a step change from 25% to 90% of full load.

# Supplemental Characteristics – RP593x, 6 kW

Supplemental characteristics are not warranted but are descriptions of performance determined by design or type testing. All supplemental characteristics are typical unless otherwise noted.

Characteristic	RP5933A		RP5935A		RP5936A	
	Source	Load	Source	Load	Source	Load
<b>Voltage Programming</b>						
Range	0 to 80 V		0 to 500 V		0 to 800 V	
Resolution	1 mV		10 mV		10 mV	
<b>Current Programming</b>						
Range	-120 to 120 A	0 to 120 A	-36 to 36 A	0 to 36 A	-24 to 24 A	0 to 24 A
Resolution	10 mA	10 mA	1 mA	1 mA	1 mA	1 mA
<b>Resistance Programming</b>						
Series resistance range	0 to 0.3 $\Omega$	-	0 to 1 $\Omega$	-	0 to 1 $\Omega$	-
Load resistance range	0.01 to 800 $\Omega$		0.1 to 5,000 $\Omega$		0.15 to 7,500 $\Omega$	
Resolution	1 m $\Omega$		10 m $\Omega$		10 m $\Omega$	
Accuracy	3 m $\Omega$		10 m $\Omega$		10 m $\Omega$	
<b>Voltage Programming Speed, No Load</b>						
Rise / fall time 10% to 90% of step	15 ms / 30ms	-	30 ms / 30ms	-	30 ms / 30ms	-
<b>Voltage Programming Speed, Full Load</b>						
Rise / fall time 10% to 90% of step	30 ms / 15 ms	-	60 ms / 30 ms	-	60 ms / 30 ms	-
<b>Source Effect (Line Regulation)</b>						
Voltage	$\leq 16$ mV	$\leq 16$ mV	$\leq 100$ mV	$\leq 100$ mV	$\leq 160$ mV	$\leq 160$ mV
Current	$\leq 72$ mA	$\leq 72$ mA	$\leq 28.8$ mA	$\leq 28.8$ mA	$\leq 14.4$ mA	$\leq 14.4$ mA
<b>Protection Capability</b>						
Overvoltage	82 V	85 V	505 V	530 V	808 V	835 V
Overcurrent	$\pm 126$ A	126 A	$\pm 37.5$ A	37 A	$\pm 25.2$ A	25.2 A
Overpower	$\pm 6,120$ W	6,120 W	$\pm 6,120$ W	6,120 W	$\pm 6,120$ W	6,120 W

# Specifications – RP594x, 12 kW Models

Unless otherwise noted, specifications are warranted over the ambient temperature range of 0 to 40 °C after a 30-minute warm-up period. Specifications apply at the output terminals, with the sense terminals connected to the output (local sensing) terminals.

Refer to the Keysight RP5900 Series documentation for the setup conditions for all performance specifications.

Supplemental characteristics are not warranted but are descriptions of performance determined by design or type testing. All supplemental characteristics are typical unless otherwise noted.

For more detailed specifications, refer to the [RP5900 Series user manual](#).

Specification	RP5943A		RP5945A		RP5946A	
	Source	Load	Source	Load	Source	Load
<b>DC Ratings</b>						
Voltage	0 to 80 V	0 to 80 V	0 to 500 V	0 to 500 V	0 to 800 V	0 to 800 V
Current	0 to ± 240 A	0 to 240 A	0 to ± 72 A	0 to 72 A	0 to ± 48 A	0 to 48 A
Power	0 to ± 12 kW	0 to 12 kW	0 to ± 12 kW	0 to 12 kW	0 to ± 12 kW	0 to 12 kW
<b>Output Ripple And Noise <sup>3</sup></b>						
CV peak-to-peak <sup>1</sup>	≤ 200 mVp-p	-	≤ 500 mVp-p	-	≤ 1,000 mVp-p	-
CV rms <sup>2</sup>	≤ 80 mVrms	-	≤ 100 mVrms	-	≤ 160 mVrms	-
<b>Load Effect (Load Regulation) <sup>3</sup></b>						
Voltage	16 mV	16 mV	100 mV	100 mV	160 mV	160 mV
Current	240 mA	240 mA	72 mA	72 mA	64 mA	64 mA
<b>Programming Accuracy <sup>3</sup></b>						
Voltage	0.03% + 24 mV		0.03% + 150 mV		0.03% + 240 mV	
Current	0.1% + 240 mA		0.1% + 72 mA		0.1% + 48 mA	
Power	0.5% + 60 W		0.5% + 60 W		0.5% + 60 W	
<b>Measurement Accuracy <sup>3</sup></b>						
Voltage	0.03% + 24 mV		0.03% + 150 mV		0.03% + 240 mV	
Current	0.1% + 380 mA		0.1% + 72 mA		0.1% + 48 mA	
Power	0.5% + 60 W		0.5% + 60 W		0.5% + 60 W	
<b>Load Transient Recovery Time <sup>3,4</sup></b>						
Recovery time	≤ 1 ms	-	≤ 1 ms	-	≤ 1 ms	-
Settling band	0.8 V	-	5 V	-	8 V	-

1. From 20 Hz to 20 MHz (-3 dB bandwidth) with resistive load, terminals ungrounded, or either terminal grounded.
2. From 20 Hz to 10 MHz (-3 dB bandwidth) with resistive load up to 400V, terminals ungrounded, or either terminal grounded.
3. Percent of value + offset; at 23 °C ± 5 °C after a 30-minute warm-up; measurement NPLC=1; valid for 1 year.
4. Time to recover to within the settling band following a step change from 25% to 90% of full load.

# Supplemental Characteristics – RP594x, 12 kW

Supplemental characteristics are not warranted but are descriptions of performance determined by design or type testing. All supplemental characteristics are typical unless otherwise noted.

Characteristic	RP5943A		RP5945A		RP5946A	
	Source	Load	Source	Load	Source	Load
<b>Voltage Programming</b>						
Range	0 to 80 V		0 to 500 V		0 to 800 V	
Resolution	1 mV		10 mV		10 mV	
<b>Current Programming</b>						
Range	-240 to 240 A	0 to 240 A	-72 to 72 A	0 to 72 A	-48 to 48 A	0 to 48 A
Resolution	10 mA	10 mA	10 mA	10 mA	10 mA	10 mA
<b>Resistance Programming</b>						
Series resistance range	0 to 0.15 $\Omega$	-	0 to 1 $\Omega$	-	0 to 1 $\Omega$	-
Load resistance range	0.005 to 400 $\Omega$		0.05 to 2,500 $\Omega$		0.08 to 3,750 $\Omega$	
Resolution	1 m $\Omega$		10 m $\Omega$		10 m $\Omega$	
Accuracy	3 m $\Omega$		10 m $\Omega$		10 m $\Omega$	
<b>Voltage Programming Speed, No Load</b>						
Rise / fall time 10% to 90% of step	15 ms / 30ms	-	30 ms / 30ms	-	30 ms / 30ms	-
<b>Voltage Programming Speed, Full Load</b>						
Rise / fall time 10% to 90% of step	30 ms / 15 ms	-	60 ms / 30 ms	-	60 ms / 30 ms	-
<b>Source Effect (Line Regulation)</b>						
Voltage	$\leq 16$ mV	$\leq 16$ mV	$\leq 100$ mV	$\leq 100$ mV	$\leq 160$ mV	$\leq 160$ mV
Current	$\leq 144$ mA	$\leq 144$ mA	$\leq 57.6$ mA	$\leq 57.6$ mA	$\leq 28.8$ mA	$\leq 28.8$ mA
<b>Protection Capability</b>						
Overvoltage	82 V	85 V	505 V	530 V	808 V	835 V
Overcurrent	$\pm 252$ A	252 A	$\pm 75$ A	75 A	$\pm 50.4$ A	50.4 A
Overpower	$\pm 12,240$ W	12,240 W	$\pm 12,240$ W	12,240 W	$\pm 12,240$ W	12,240 W

# Common Characteristics – All Models

Common characteristic	All models
Command processing time	≤ 0.1 ms from receipt of command to start of output change. Applies to simple setting commands over the GPIB interface
Parallel capability	Up to 16 units can be connected in primary / secondary mode
<b>Computer Interfaces</b>	
LXI	1.5 LXI Device Specification 2016
LAN	10 Mb, 100 Mb, 1 Gb LAN
USB	USB 2.0 (USB-TMC488 protocol)
GPIB	SCPI - 1993, IEEE 488.2 compliant interface
CAN	CAN 2.0A and CAN 2.0B compatible (CANopen protocol)
Analog	0 to 10 V full scale
Web Server	Support remote control, transfer screen, screenshot, upgrade program, and so on
<b>Constant Dwell ARBs</b>	
Number of points	Up to 65,535
Dwell range	One dwell setting applies for the entire ARB, from 1 ms to 3,600 s
<b>Regulatory Compliance</b>	
EMC	Complies with European EMC Directive for test and measurement products
	Complies with Australian standard and carries C-Tick mark
	This ISM device complies with Canadian ICES-001
	Cet appareil ISM est conforme à la norme NMB-001 du Canada
Safety	Complies with European Low Voltage Directive and carries the CE mark
	Conforms to US and Canadian safety regulations
	Declarations of Conformity for this product may be downloaded from the Web. Go to <a href="http://www.keysight.com/go/conformity">http://www.keysight.com/go/conformity</a> and click on "Declarations of Conformity"
<b>Output Terminal Isolation</b>	
For 80 VDC models – RP59x3A	No output terminal may be more than ± 300 VDC from any other terminal or chassis ground
For 500 VDC models – RP59x5A	No output terminal may be more than ± 800 VDC from any other terminal or chassis ground
For 800 VDC models – RP59x6A	No output terminal may be more than ± 1000 VDC from any other terminal or chassis ground
<b>AC Input</b>	
Connections	L1, L2, L3, PE
Nominal AC input range and frequency	RP5913A, RP5923A, RP5915A, RP5925A, RP5916A, RP5926A: 3-phase; 110 - 520 VAC, 50 / 60 Hz RP5933A, RP5943A, RP5935A, RP5945A, RP5936A, RP5946A: 3-phase; 380 - 520 VAC, 50 / 60 Hz NOTE: 6 kW and 12 kW models can be operated at 200VAC-208VAC AC mains input, with the condition that the current and power ratings are reduced by ~35%.
Input VA	Max. Apparent Power: RP591xA Models: 2.25 kVA, RP592xA Models: 4.5 kVA,

	RP593xA Models: 6.5 kVA, RP594xA Models: 13kVA
	Max. AC Current: R591xA, RP592xA, RP593xA Models: 12.5 A RP594xA Models: 25 A
	Max Efficiency: RP5913A: 89%, RP5923A: 91.5%, RP5933A: 92%, RP5943A: 92% RP5915A: 90%, RP5923A: 92.5%, RP5933A: 93%, RP5943A: 93% RP5913A: 90%, RP5923A: 92.5%, RP5933A: 93%, RP5943A: 93%
Power factor	0.99 at nominal input and rated power
<b>Environmental</b>	
Operating environment	Indoor use, installation category II (for AC Input), pollution degree 2
Operating temperature range	0 – 40 °C
Programming temperature coefficient	Voltage: ≤ 30 ppm / °C Current: ≤ 50 ppm / °C
Measurement temperature coefficient	Voltage: ≤ 30 ppm / °C Current: ≤ 50 ppm / °C
Relative humidity	20% to 80% relative humidity (non-condensing)
Storage temperature	-10 – 70 °C
Altitude	Up to 2,000 meters
Storage temperature	-10 °C to 70 °C
Acoustic statement (European Machinery Directive)	Acoustic noise emission 1U Models: LpA ≤ 69.2 dB at Operating position; LpA ≤ 66.7 dB at Bystander position; LpA ≤ 73.2 dB at Worst-case fan speed 2U Models: LpA ≤ 78.5 dB at Operating position; LpA ≤ 75.1 dB at Bystander position; LpA ≤ 75.4 dB at Worst-case fan speed Normal operating mode per ISO 7779
ESD immunity	Up to ±8 kV contact discharge Up to ±12 kV air-gap discharge
<b>Digital Port</b>	
Max voltage rating	5V
<b>Typical Weight</b>	
	RP591xA: 26.5 lbs. (12 kg)
	RP592xA: 29.8 lbs. (13.5 kg)
	RP593xA: 33.1 lbs. (15 kg)
	RP594xA: 66.2 lbs. (30 kg)
<b>Dimensions</b>	
RP591xA, RP592xA, RP593xA models	1U, full rack width (see Outline Diagrams for details)
RP594xA models	2U, full rack width (see Outline Diagrams for details)

# Output Quadrants

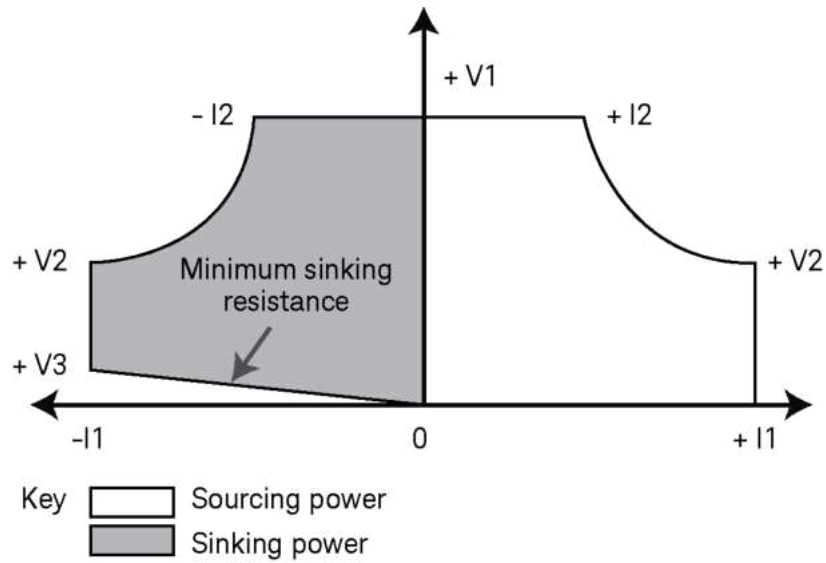
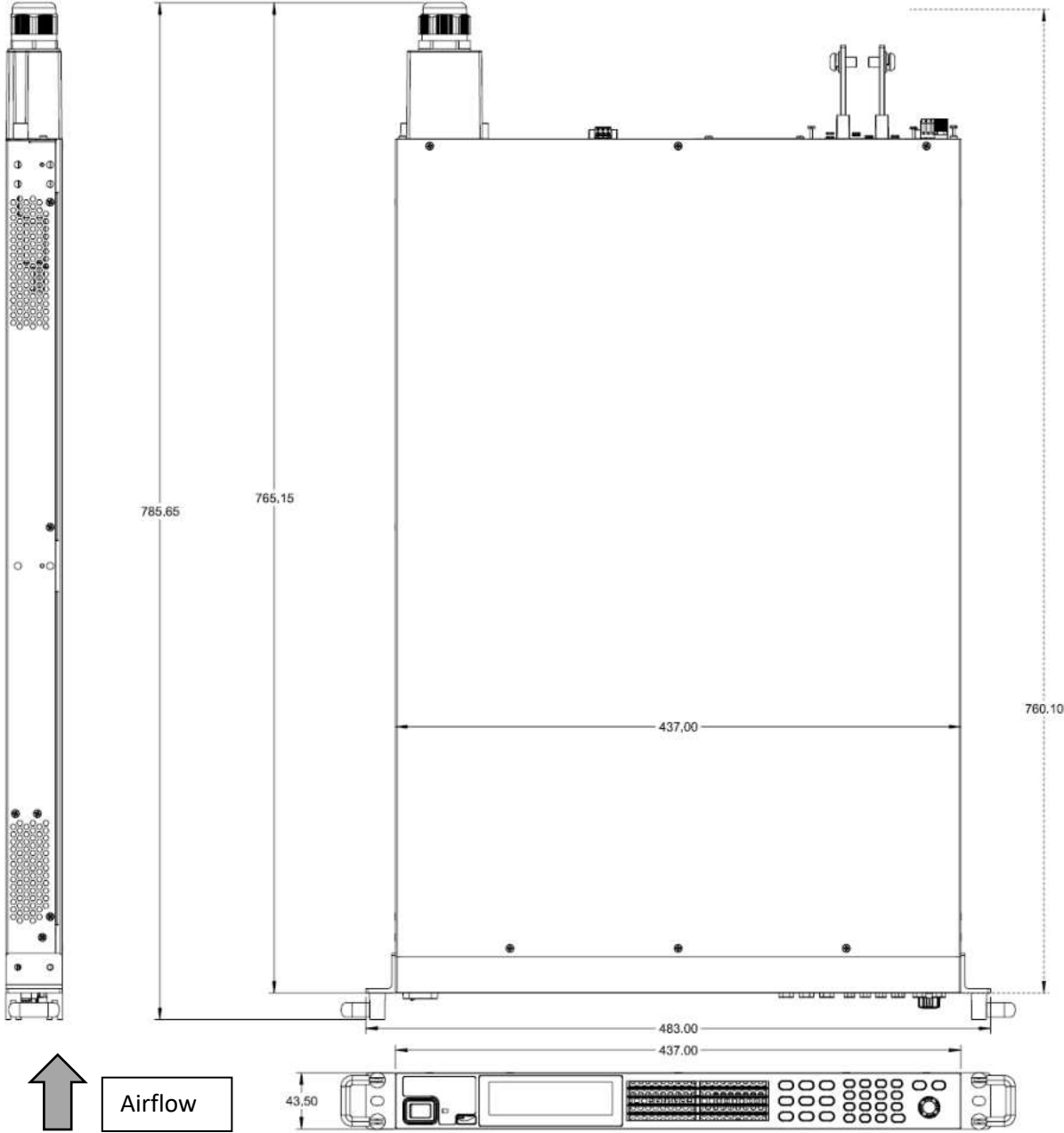

Figure 7. RP5900 output characteristic

Model	+ V1	+ V2	+ V3	± I1	± I2	Minimum Sink Resistance
RP5913A	80 V	50 V	0.8 V	40 A	25 A	20 mΩ
RP5915A	500 V	167 V	2.5 V	12 A	4 A	208 mΩ
RP5916A	800 V	250 V	4 V	8 A	2.5 A	500 mΩ
RP5923A	80 V	50 V	0.8 V	80 A	50 A	10 mΩ
RP5925A	500 V	167 V	2.5 V	24 A	8 A	104 mΩ
RP5926A	800 V	250 V	4 V	16 A	5 A	250 mΩ
RP5933A	80 V	50 V	0.8 V	120 A	75 A	6.7 mΩ
RP5935A	500 V	167 V	2.5 V	36 A	12 A	70 mΩ
RP5936A	800 V	250 V	4 V	24 A	7.5 A	166 mΩ
RP5943A	80 V	50 V	0.8 V	240 A	150 A	3.3 mΩ
RP5945A	500 V	167 V	2.5 V	72 A	24 A	35 Ω
RP5946A	800 V	250 V	4 V	48 A	15 A	83 mΩ

# Outline Diagrams – 1U Models

RP5913A, RP5915A, RP5916A, RP5923A, RP5925A, RP5926A, RP5933A, RP5935A, RP5936A



# Outline Diagrams – 2U Models

RP5943A, RP5945A, RP5946A

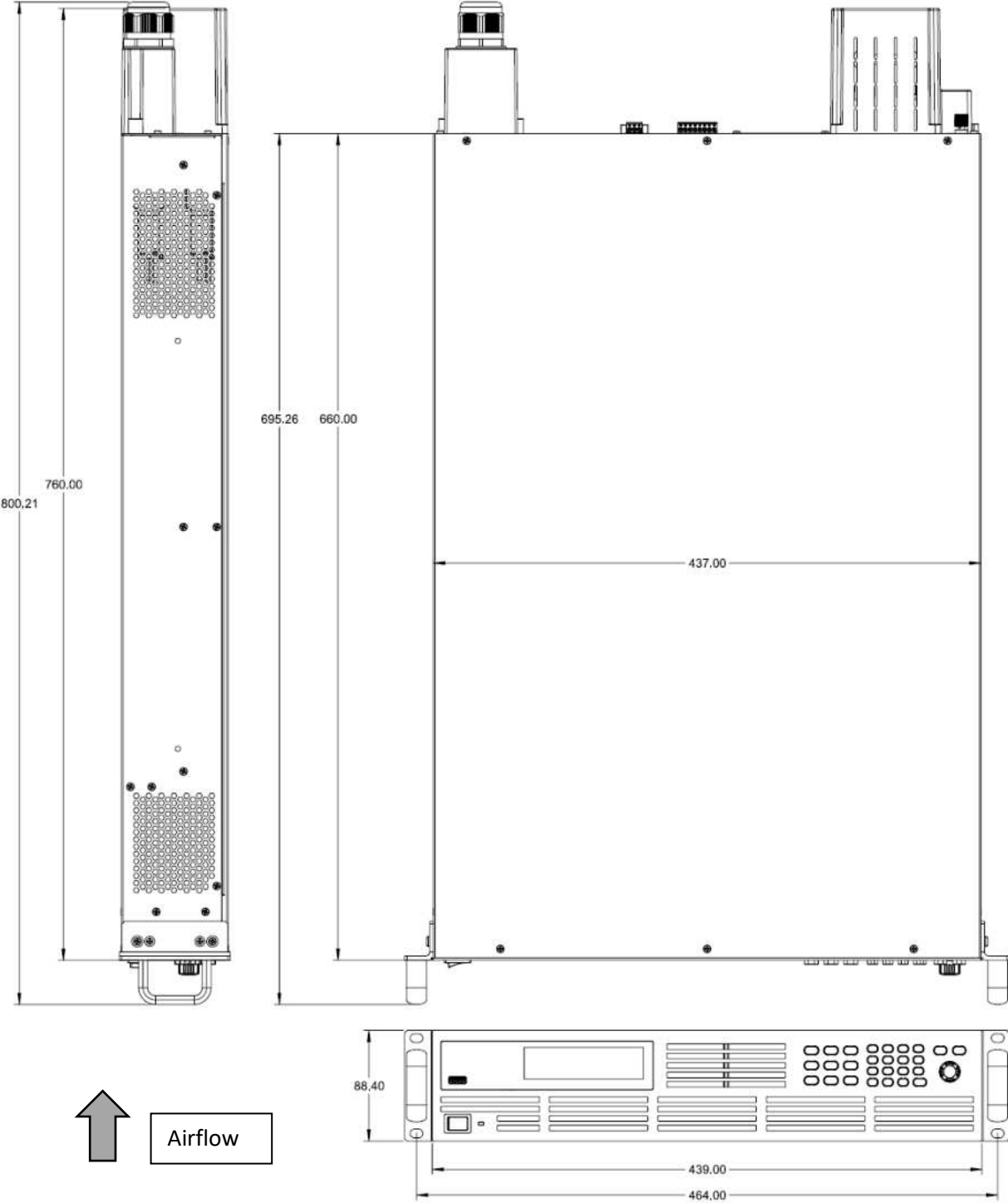

# Ordering Information

## Available Models

### Regenerative Power System Models

RP5913A	Regenerative DC power supply	80V, ± 40 A, 2 kW
RP5915A	Regenerative DC power supply	500V, ± 12 A, 2 kW
RP5916A	Regenerative DC power supply	800 V, ± 8 A, 2 kW
RP5923A	Regenerative DC power supply	80 V, ± 80 A, 4 kW
RP5925A	Regenerative DC power supply	500 V, ± 24 A, 4 kW
RP5926A	Regenerative DC power supply	800 V, ± 16 A, 4 kW
RP5933A	Regenerative DC power supply	80 V, ± 120 A, 6 kW, 380/480 VAC
RP5935A	Regenerative DC power supply	500 V, ± 36 A, 6 kW, 380/480 VAC
RP5936A	Regenerative DC power supply	800 V, ± 24 A, 6 kW, 380/480 VAC
RP5943A	Regenerative DC power supply	80 V, ± 240 A, 12 kW, 380/480 VAC
RP5945A	Regenerative DC power supply	500 V, ± 72 A, 12 kW, 380/480 VAC
RP5946A	Regenerative DC power supply	800 V, ± 48 A, 12 kW, 380/480 VAC

## Line Cords and Terminations (Plugs)

Due to the number of different line cords and terminations around the world, the RP5900 power supplies do not come with line cords or terminations. Users will need to supply their own, depending on the local laws and codes of the country / region where the power supply will be used.

## Accessories

### Accessories

PW9252A	PathWave Advanced Power Control and Analysis application
PW9253A	PathWave Advanced Battery Test and Emulation application
RP5901C	GPIB interface board for EL4900 Series DC loads and RP5900 Series supplies
RP5902C	Analog / RS-232 interface board for EL4900 Series DC loads and RP5900 Series supplies
RP5903C	Parallel kit — Fiber optics cable and transmitter module
RP5904C	Rack-mount kit 1U for EL4900 Series DC loads and RP5900 Series supplies
RP5905C	Rack-mount kit 2U for EL4900 Series DC loads and RP5900 Series supplies

# Keysight Support Services

Accelerate your learning curve, enhance your test uptime, and confidently guarantee your instrument accuracy with Keysight Support Services. Keysight Services are here to support your test needs with expert technical support, instrument repair and calibration, training, alternative acquisition program options, and more.

A KeysightCare agreement provides dedicated, proactive support through a single point of contact for an extensive group of instruments, software, and solutions to ensure optimal uptime, with fast response times and resolution. Explore the services that are right for you.

## Keysight Services

Offering	Benefits
<p><b>KeysightCare</b></p> 	<p>KeysightCare provides elevated support for Keysight instruments and software, with access to technical support experts who respond within a specified time and ensure committed repair and calibration turnaround times (TAT). KeysightCare offers multiple service agreement tiers, including KeysightCare Assured, Enhanced, and Application Software Support. See the <a href="#">KeysightCare data sheet</a> for details.</p>
<p>KeysightCare Assured</p>	<p>KeysightCare Assured provides a commitment to respond to your engineer's technical needs quickly. When unexpected repairs are necessary, you can count on a committed repair service turnaround time to get you back up and running.</p>
<p>KeysightCare Enhanced</p>	<p>KeysightCare Enhanced includes all the benefits of KeysightCare Assured plus Keysight's accurate and reliable <a href="#">Calibration Services</a>, accelerated and committed TAT, and technical response.</p>
<p><b>Keysight Support Portal and Knowledge Center</b></p>	<p>All KeysightCare tiers include access to the Keysight Support Portal, where you can manage support and service resources related to your assets, such as service requests and status, or browse the Knowledge Center.</p>
<p><b>Education Services</b></p>	<p>Build confidence and gain new skills to make accurate measurements, with flexible Education Services developed by Keysight experts, including Start-up Assistance.</p>
<p><b>Alternative Acquisition Options</b></p>	
<p><b>KeysightAccess</b></p>	<p>Reduce budget challenges with a lease-based subscription service that offers low monthly payments, enabling you to get the instruments, software, and technical support you want for your test needs.</p>

## Recommended Services

Maximize your instrument uptime and confidently make accurate measurements by securing technical support, repair, and calibration services with committed response and turnaround times. High-performance instruments include 1 year of KeysightCare Assured. Obtain multi-year KeysightCare upfront to eliminate the need for lengthy and tedious paperwork and yearly requests for maintenance budget. Plus, you benefit from secured service for 2, 3, or 5 years.

Service	Function
<b>KeysightCare Enhanced*</b>	<b>Includes Tech Support, Warranty, and Calibration</b>
R-55B-001-1	KeysightCare Enhanced – Upgrade 1 year
R-55B-001-2	KeysightCare Enhanced – Extend to 2 years
R-55B-001-3	KeysightCare Enhanced – Extend to 3 years (Recommended)
R-55B-001-5	KeysightCare Enhanced – Extend to 5 years (Recommended)
<b>KeysightCare Assured</b>	<b>Includes Tech Support and Warranty</b>
R-55A-001-2	KeysightCare Assured – Extend to 2 years
R-55A-001-3	KeysightCare Assured – Extend to 3 years
R-55A-001-5	KeysightCare Assured – Extend to 5 years
<b>Start-Up Assistance</b>	
PS-S40-01	Included – instrument fundamentals and operations starter
PS-S40-04	Recommended – instrument fundamentals and operations starter
PS-S40-02	Optional, technology and measurement science standard learning

\*Available in select countries. For details, please see the [datasheet](#). R-55B-001-2/3/5 must be ordered with R-55B-001-1.

# Definitions

## Specification (spec)

The warranted performance of a calibrated instrument that has been stored for a minimum of two hours within the operating temperature range of 0 to 55 °C and after a one-hour warm-up period. All specifications account for the effects of measurement and calibration-source uncertainties and were created in compliance with ISO-17025 methods. Data published in this document are specifications (spec) only where specifically indicated.

## Typical (typ)

The characteristic performance that 80% or more of manufactured instruments will meet. This data is not warranted, does not include measurement or calibration-source uncertainty, and is valid only at room temperature (approximately 23 °C).

## Nominal (nom)

The mean or average characteristic performance, or the value of an attribute that is determined by design, such as a connector type, physical dimension, or operating speed. This data is not warranted and is measured at room temperature (approximately 23 °C).

## Measured (meas)

An attribute measured during product development for the purpose of communicating expected performance. This data is not warranted and is measured at room temperature (approximately 23 °C)

## TCAL

The temperature at which the instrument was calibrated.

## For More Information

Visit [www.keysight.com/find/RP5900](http://www.keysight.com/find/RP5900)



Keysight enables innovators to push the boundaries of engineering by quickly solving design, emulation, and test challenges to create the best product experiences. Start your innovation journey at [www.keysight.com](http://www.keysight.com).

This information is subject to change without notice. © Keysight Technologies, 2025, Published in USA, September 11, 2025, 3125-1369.EN