

R&S® ESSENTIALS

R&S® RT-ZISO ISOLATED PROBING SYSTEM

High voltage. Optical isolation. Seamless operation.

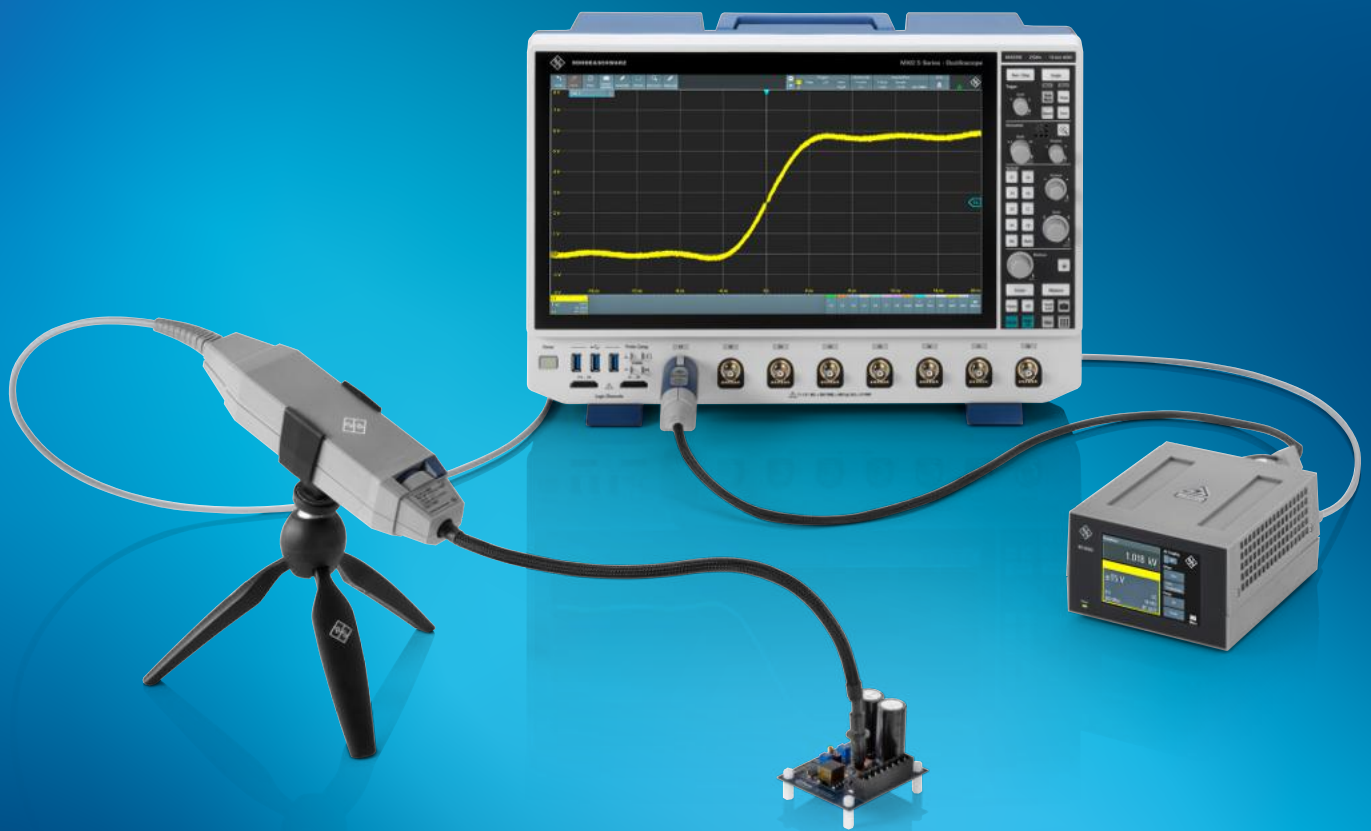

Product Brochure
Version 03.00

ROHDE & SCHWARZ

Make ideas real



NEXT GENERATION GROUND BREAKING SOLUTION

The R&S®RT-ZISO isolated probing system sets new standards in optical probe technology. The innovative solution delivers unparalleled accuracy, sensitivity, dynamic range and bandwidth while enabling next-generation wide bandgap (WBG) SiC and GaN power designs. The remarkable R&S®RT-ZISO can make precise differential measurements up to ± 3000 V on common mode voltage of ± 60 kV with rise times up to < 450 ps. The solution can suppress fast common mode edges that would otherwise distort and disturb accurate measurements.

Versatile and accurate probing

The micro-miniature coaxial (MMCX) connector has reliable noise shielding and is widely used in WBG testing solutions. The connector ensures smaller commutation loops and minimizes parasitic capacitance that can cause high common mode noise in circuits. A voltage rating of 170 V (RMS) in continuous mode and a maximum rating of 500 V (RMS) make it the ideal probe point on transistor gate nodes.

The R&S®RT-ZISO has MMCX probe tips with 1.5:1, 8 V (RMS), ± 45 V (peak) and 10:1, ± 300 V (RMS) ranges that can meet all measurement needs. Also, probe tips for 2.54 mm pitched square pins and 5.08 mm pitched wide square pins are available. Tips with passive probes (browser) are available with a safety rating of 1000 V CAT III for maximum probe flexibility.

Optical isolation

The R&S®RT-ZISO isolated probing system is designed for measurement challenges in high voltage and fast switching environments. The power-over-fiber (PoF) architecture galvanically isolates the device under test (DUT) from the measurement setup for the highest common mode rejection ratio (CMRR) at frequencies up to 1 GHz. The complete system compensates thermal drifts and rectifies gain errors for uncompromising signal fidelity.

Applications

Evolving WBG technologies such as SiC, GaN FET and improved insulated-gate bipolar transistor (IGBT) devices offer faster slew rates and higher voltage levels. Circuit topologies can be characterized in detail with:

- ▶ Switching converters and WBG devices
- ▶ Double-pulse testing
- ▶ Floating measurements
- ▶ Shunt measurements
- ▶ Inverter design
- ▶ Motor drive analysis

KEY FACTS

- ▶ 100 MHz to 1 GHz bandwidth (upgradeable)
- ▶ > 90 dB ($> 30\,000:1$) CMRR at 1 GHz
- ▶ ± 3000 V input range for differential voltage and offset range
- ▶ ± 60 kV CMRR input range
- ▶ ± 10 mV most sensitive input range
- ▶ Two connection options: Rohde & Schwarz probe interface or SMA

AT A GLANCE

Probe head

- ▶ Electro-optical converter on probe signal
- ▶ SMA interface to probe tips

Probe tips

- ▶ Safe attach feature to easily interface different probe tips
- ▶ Automatic tip identification

Probe receiver

- ▶ Touchscreen control for probe settings
- ▶ R&S®ProbeMeter: high precision measurement of RMS value
- ▶ Signal conditioning and signal compensation

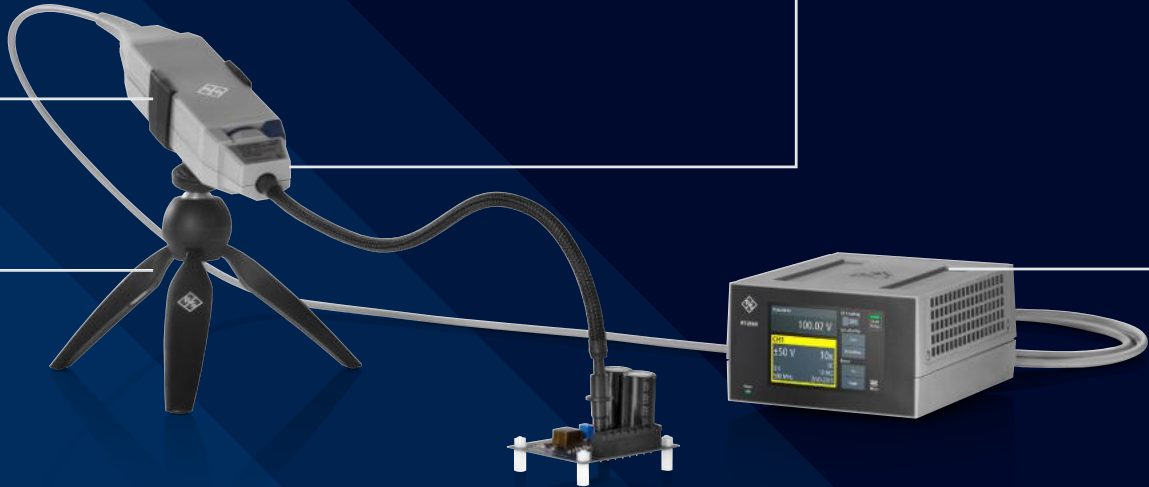

Probe stand

- ▶ Flexible and stable probe positioning
- ▶ Support tripod stand with 1/4"-20 UNC thread

Probe tips for different probing need

- ▶ Probe tips support MMCX, square pins, wide square pins and passive probes
- ▶ Ductile tip cables provide easy access with low mechanical stress on the probe point

Probe receiver interface (back)

- ▶ Supports Rohde & Schwarz probe interface and SMA to BNC connection to any oscilloscope



PROBING CHALLENGES WITH FAST COMMON MODE TRANSIENTS

Common mode transients occur when measuring totem-pole complementary FET setups in half-bridge converters, synchronous rectifiers and bidirectional switches. Rapidly changing voltage levels on switch nodes can make it difficult for conventional high voltage differential probes in high-side gate-source measurements to attenuate common mode signals at high frequencies.

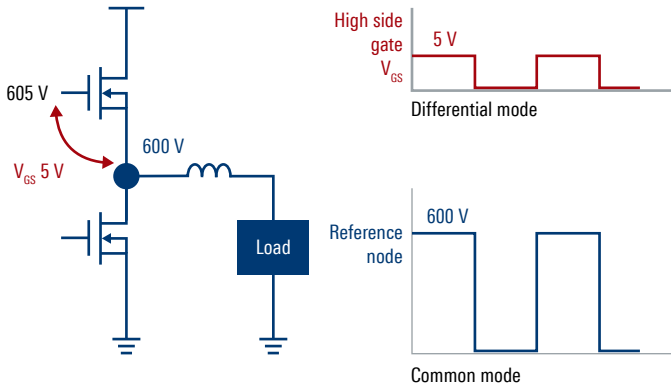

In isolated power conversions, the lack of a common ground leaves DUT floating. Measurement setups with ground references can form ground loops that couple common mode noise and affect sensitive measurement results. The phenomenon is common in high power, three-phase inverters and motor drives.

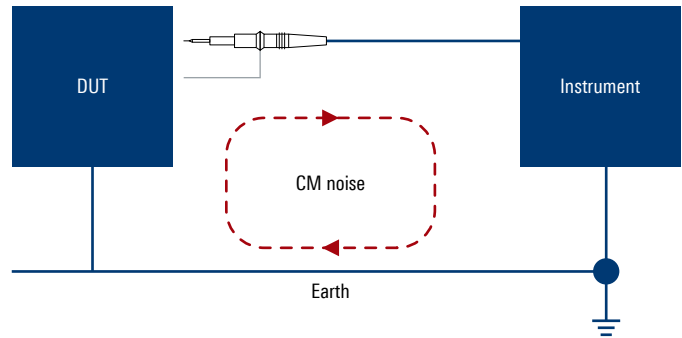

CMRR limitations for conventional probing solutions

High voltage differential probes are the most common solution for measurements in power electronics. By subtracting the negative (-) from the positive (+) input voltage, the common mode is canceled out completely in ideal differential amplifiers. The common mode rejection ratio (CMRR) defines the effectiveness of the probe suppression of common mode signals.

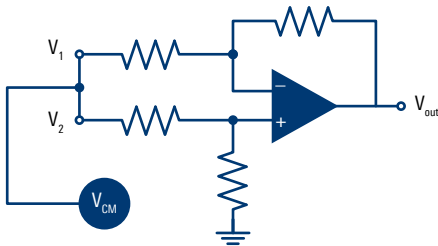

$$V_{out} = A_{dm}(V_1 - V_2) + A_{cm}(V_{cm})$$

$$CMRR = \left(\frac{A_{dm}}{|A_{cm}|} \right)$$

$$CMRR_{dB} = 20 \log_{10} \left(\frac{A_{dm}}{|A_{cm}|} \right)$$

Increased bandwidth for derating CMRR and voltage

Most high voltage differential probes have excellent CMRR ratings at low frequencies (< 100 Hz). These probes rely on the matching of two internal input dividers. As frequency increases, parasitic effects increase and matching becomes more difficult, if not impossible. As a result, the CMRR and voltage rating drops when the frequency (slew rate) for signals increases.

Conventional high voltage differential probes typically have < 30 dB of CMRR at their rated operation frequency from 100 MHz to 200 MHz. In scenarios where high CMRR is not needed, these probes deliver good measurement results.

CMRR for a typical high voltage differential probe in dB

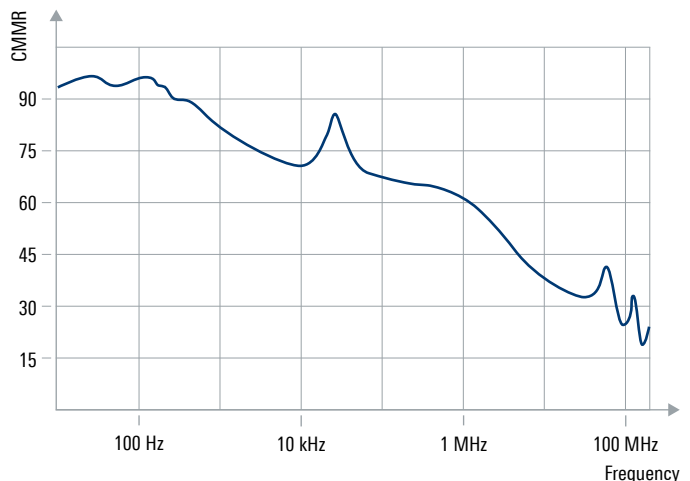

ISOLATION WITH OPTICAL FIBER

Isolating ground connections is important for reducing common noise loops. The R&S®RT-ZISO isolated probing system uses lasers to communicate between the probe head and the probe receiver to eliminate possible electrical return paths for common mode signals. The probe tip and the probe head are essentially floating and measurement signals are optically transmitted to the probe receiver. Even when the instrument and DUT can be connected on the same ground plane, the lack of an electrical path completely isolates the common mode loops.

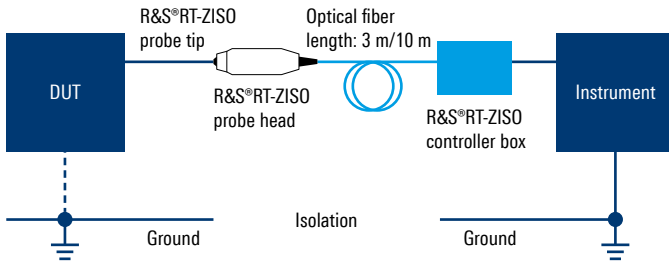

The signal transmission from the probe head to the probe receiver box is made with an optical connection and the necessary power supply for the probe head is transmitted over fiber. The probe head does not need an external power source, eliminating common mode loops. A battery can also be used as a power source.

Another benefit of using optical fiber for isolation is the longer possible distance to the oscilloscope. Especially in critical high-power environments, high frequency and strong common mode noise limit safe proximity to the DUT. The R&S®RT-ZISO can have 3 m or 10 m optical fibers.

Bandwidth

While the R&S®RT-ZISO was designed for power applications, most important one is measuring CMRR at high bandwidths. Faster rise and fall times in switching are critical for bandwidth requirements.



> 90 dB CMRR with ± 60 kV at 1 GHz

100 MHz to 1 GHz bandwidth

± 3000 V input and offset range

Dual connectivity modes

Bandwidth options

	R&S®ZISO-B901	R&S®ZISO-B902	R&S®ZISO-B903	R&S®ZISO-B905	R&S®ZISO-B910
Bandwidth	100 MHz	200 MHz	350 MHz	500 MHz	1 GHz
Rise time (10% to 90%)	< 4 ns	< 2 ns	< 1.14 ns	< 800 ps	< 450 ps

PROBE TIPS MATTER



Probe tips and connectors also have an impact on CMRR. One reason why conventional high voltage differentials hardly meet requirements is that the connection to the probe point is usually a 4 mm banana plug or jack, often with crocodile clamps or long needle tips. The connections are needed to safely use high voltage and maintain sufficient creepage distance. The slightest mismatch in the signal path between positive and negative terminals reduces the effectiveness of differential operational amplifiers when suppressing common mode noise. Long cables and a lack of shielding make it susceptible to common mode noise around the DUT.

R&S®RT-ZISO has a variety of probe tips. The MMCX probe tip has the best CMRR. The coaxial approach shields the signal path and minimizes interference. The uniform coaxial distance for the tip cable also keeps the common mode loop to a minimum. Test points should be used with MMCX connectors to maximize measurement signal fidelity. Square and wide square pin sockets tips are also available but lose some of the CMRR especially at high frequency range.



R&S®ZISO-Z101: MMCX, 1.5:1, 8 V (RMS), ±45 V (max.);

R&S®ZISO-Z201: MMCX, 10:1, ±300 V (RMS)

The MMCX connector has the best signal fidelity with an excellent CMRR at high bandwidths. For measurements with < 700 ps rise time, consider using test points with an MMCX connector. The low attenuation of the probe tip can only support a limited input and offset range but is important for measurements that require high sensitivity and lower noise levels.



R&S®ZISO-Z202: square pin (SQPIN), 25:1, ±750 V (RMS), 2.54 mm pitch

Even though the square pin can be easily used as a test point during design, the proximity may not meet creepage requirements and can lead to arcing. The R&S®ZISO-Z202 can measure up to ±750 V and a ±750 V offset range can be used. As mentioned earlier, the CMRR performance and voltage range degrades as bandwidth increases.



R&S®ZISO-Z203: wide square pin (WSQPIN), 100:1, ±2500 V (RMS), 5.08 mm pitch

Higher voltage requires larger dimensions between exposed test leads, because of the greater creepage distance. The wide square pin tips support larger input voltage ranges and offsets. The larger input loop degrades CMRR performance especially at higher frequencies.



R&S®ZISO-Z301: browser, 10:1, ±300 V (RMS);

R&S®ZISO-Z302: browser, 100:1, ±3540 V (RMS)

Isolated browsers are very useful for easy measurements on DUTs without dedicated test points. Their 120 cm long tip cables enable flexible functional testing and troubleshooting.

The isolated probing system from Rohde & Schwarz focuses on safety. The probe system is specified for a CAT III and various probe tips are designed to limit exposure to metal contact points.

Probe tips key performance

Parameter	R&S® ZISO-Z101	R&S® ZISO-Z201	R&S® ZISO-Z202	R&S® ZISO-Z203	R&S® ZISO-Z301	R&S® ZISO-Z302
Input interface	MMCX	MMCX	square pin (2.54 mm)	wide square pin (5.08 mm)	browser	browser
Cable length	37 cm (14 in)	21 cm (8 in)	32 cm (12 in)	38 cm (15 in)	120 cm (47 in)	120 cm (47 in)
Attenuation	1.5:1	10:1	25:1	100:1	10:1	100:1
DC input resistance	50 Ω	10 MΩ	10 MΩ	40 MΩ	10 MΩ	100 MΩ
Input capacitance	< -12 dB ¹⁾	3.7 pF	3.5 pF	3.2 pF	12 pF	4.6 pF
Maximum measurement input voltage	8 V (RMS), ±45 V (peak)	±300 V (RMS), ±500 V (peak)	±750 V (RMS), ±1000 V (peak)	2500 V (RMS), ±3500 V (peak)	±300 V (RMS)	±3540 V (RMS)
Adjustable offset voltage	±45 V	±300 V	±750 V	±3000 V	±300 V	±3000 V
Voltage to earth	1000 V CAT III	1000 V CAT III	1000 V CAT III	1000 V CAT III	300 V CAT III	1000 V CAT III
Operating temperature range	0°C to +40°C					

¹⁾ R&S® ZISO-Z101 has a 50 Ω match impedance so dB value indicates the reflection coefficient.

Probe tip CMRR performance and input voltage derating over frequency

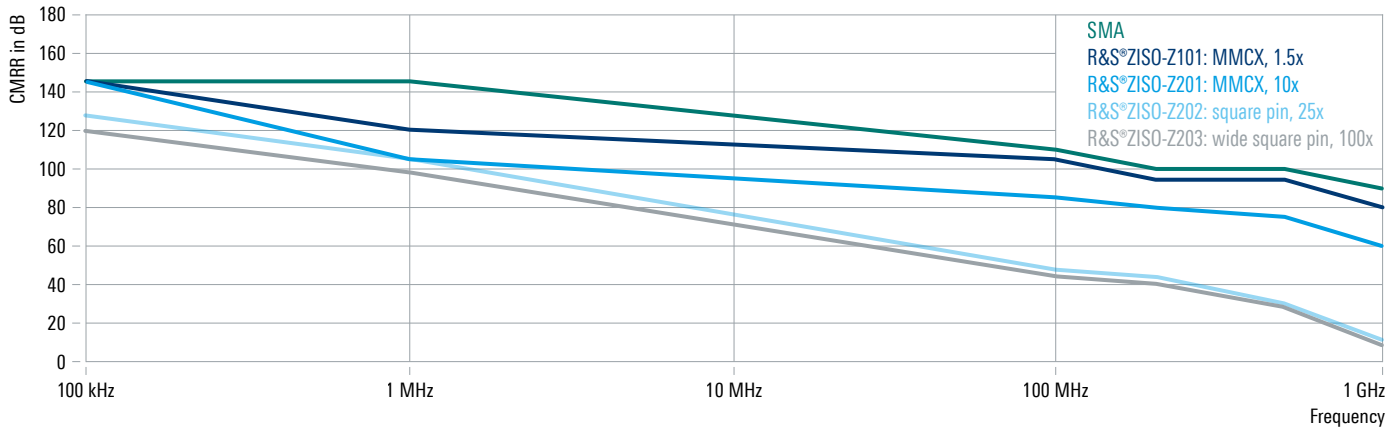

Mechanical considerations

DUTs come in different sizes and suitable test points are often in awkward locations. We designed a solution with a longer probe tip and a ductile cable. Additional shielding for better noise suppression increases cable stiffness and weight while adding mechanical stress onto the DUT. The ductile cable lets probe tip be bent and shaped into the desired angle and minimize stress on the connection point. The MMCX requires axial force of at least 20 N to detach.

In power applications, components on a DUT can get hot. Surface mount (SMD) connector types for good measurements with test points nearby can easily give way when overstressed by the probe tip weight. Through-hole connectors help keep the probe tip stable but impact the circuit board layout by allocating space in all layers for the connector. The connectors also increase parasitic inductance. The R&S® RT-ZISO helps minimize the mechanical loads for more accurate measurements while extending the lifetime of connectors.



HIGH-SIDE MEASUREMENT

In switch mode power supplies, half-bridge and totem-pole setups are common. Designers need to note switching transients and gate timing for optimum efficiency. The lack of a ground reference makes high-side measurements challenging. Fast and high voltage switching of a source node generates fast common signals between the gate and source of high-side transistors. When double-pulse testing is used to characterize power devices, the ones on the high-side configuration are tested. Input characteristics are dominated by Miller capacitance and can be difficult to observe in the presence of common mode interference.

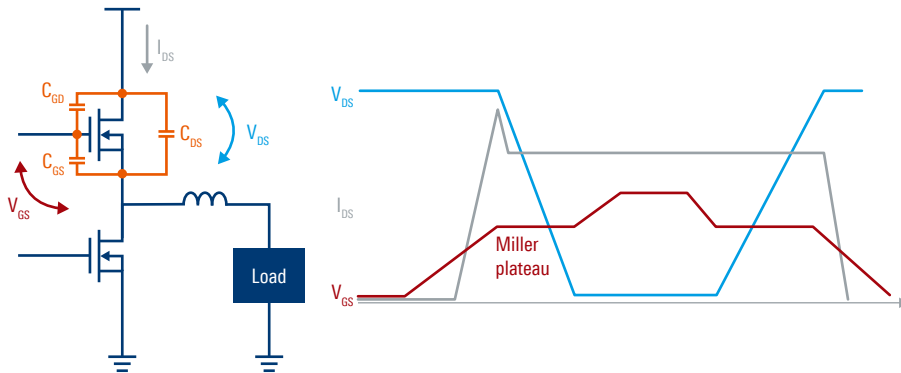

The screenshot is of the high-side gate to source measurement with the R&S®RT-ZISO. The slight dip of about 1.85 ns is the Miller plateau that the CM switching signal at the source node of the high-side transistor would otherwise obscure. Shorter rise/fall times reduce switching losses and enable a faster response to changing loads. Conventional high voltage differential probes with limited CMRR at high frequencies face challenges when measuring DC circuits that use newer technologies and architecture.



CURRENT MEASUREMENT WITH SHUNT

The pristine noise performance and high sensitivity of the R&S®RT-ZISO isolated probe system can also be used with high bandwidth current. Traditional current measurements with Hall effect sensors, transformer coils and Rogowski coils are limited by their ability to keep up with magnetic field changes from fast switching current. Shunt current measurements offer higher bandwidth and are a cost-effective approach. Low shunt values limit the power dissipation and effects on the DUT. The resulting small burden voltage is very sensitive to noise. A high CMRR is required, when a common mode voltage is applied to the shunt resistor.

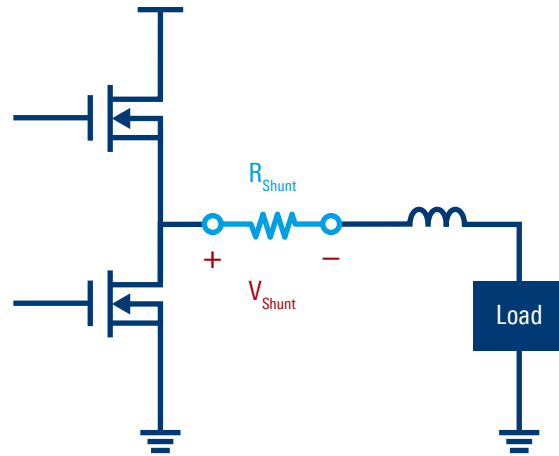

DC characteristics

Attenuation error	after self-alignment	
	input voltage range < ± 0.01 V	$\pm 1.5\%$ full scale
	input voltage range ± 0.01 V	$\pm 2.5\%$ full scale
Temperature drift, attenuation		$\pm 0.15\%/^{\circ}\text{C}$ (meas.)
Zero error	after self-alignment (input related)	± 0.5 mV $\pm 0.02 \times$ input voltage range
Offset compensation range	in all applicable attenuation settings	± 30 V

Sensitivity and noise

Input range	R&S®ZISO-B901 (100 MHz)	R&S®ZISO-B902 (200 MHz)	R&S®ZISO-B903 (350 MHz)	R&S®ZISO-B905 (500 MHz)	R&S®ZISO-B910 (1 GHz)
± 0.01 V	107 μV	121 μV	153 μV	172 μV	245 μV
± 0.025 V	140 μV	161 μV	220 μV	252 μV	383 μV
± 0.05 V	211 μV	255 μV	363 μV	417 μV	623 μV
± 0.1 V	382 μV	465 μV	683 μV	780 μV	1.16 mV
± 0.5 V	1.84 mV	2.26 mV	3.35 mV	3.81 mV	5.65 mV
± 1 V	5.90 mV	7.27 mV	9.49 mV	10.9 mV	16.0 mV

Noise performance depends highly on system bandwidth and requires a high CMRR for fast switching current measurements. The R&S®RT-ZISO has the highest sensitivity in the industry, down to ± 10 mV range and offers superb noise performance. Frequency response and thermal stability are even more important. Each probe head comes with Rohde&Schwarz designed ASICs trimmed to have a flat frequency response and minimized thermal drift. The ASICs and dedicated frontends offer multiple input ranges to especially improve small shunt current sensitivity. The frontend comes with the built-in Rohde&Schwarz patented R&S®ProbeMeter, which is an established feature for precise RMS measurement available in all Rohde&Schwarz active probes.

CONNECT

Operating the R&S®RT-ZISO via the Rohde&Schwarz probe interface offers seamless control over the probe system. The tip data is read out automatically and processed by the oscilloscope to set up the correct system attenuation and skew. Offset and range control can be easily configured on the oscilloscope. The Rohde&Schwarz probe interface also delivers power to the probe system directly. Setting up the R&S®RT-ZISO with a Rohde&Schwarz oscilloscope ensures the correct settings for your measurement. Users can also get the highest acquisition rate, finer details with 18-bit vertical resolution and access to features such as zone trigger and fast spectrum for deep waveform insights.



Alternatively, the R&S®RT-ZISO isolated probing system lets you connect to any oscilloscope with a BNC or SMA interface. The probe receiver comes with a touchscreen display to control and view probe system settings. This makes controlling the input range and the offset settings easy while also indicating the connected probe tip.

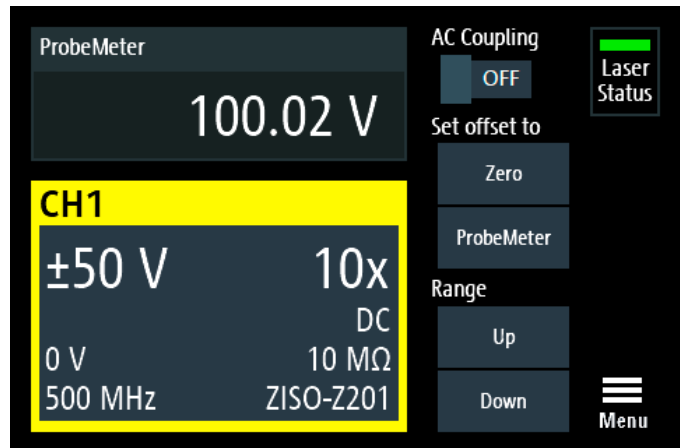

Protecting your investment

R&S®RT-ZISO bandwidth can be easily upgraded for those with tight project budgets. The 100 MHz bandwidth has the lowest entry level price for an optically isolated probing system. The probe bandwidth can be upgraded later and there is no need to buy a whole new probe. The probe has an oscilloscope independent interface and investments in Rohde&Schwarz solutions for wideband measurements with high CMRR can be made incrementally. The probe system can work with any third-party oscilloscope for a flexible setup.



Bandwidth upgrading and servicing the isolated probing system requires hardware changes. The calibration to meet the voltage specifications can be done in-house at any Rohde&Schwarz service center near you.

Bandwidth upgrade options

- ▶ R&S®ZISO-B202: upgrade to 200 MHz
- ▶ R&S®ZISO-B203: upgrade to 350 MHz
- ▶ R&S®ZISO-B205: upgrade to 500 MHz
- ▶ R&S®ZISO-B210: upgrade to 1 GHz

TEST SAFELY

Safety is often overlooked in isolated probing systems. High frequency and high power create challenging demands for test environments and require a high CMRR. The IEC/EN61010-31 standard is vital to handheld probe systems. The R&S®RT-ZISO isolated probing system complies to these safety specifications for a maximum input voltage of 1000 V (RMS) CAT III.

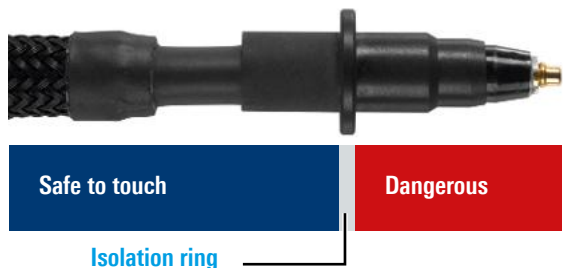

1000 V CAT III safety rating

The probe head is highly isolated to minimize exposed operation. Each probe tip is designed with an isolation ring that indicates the safe handling zone. This allows R&S®ZISO-Z301 and R&S®ZISO-Z302 isolated passive probes to be used for quick access to measurement locations when debugging.



Safe attach on probe tips

Another R&S®ZISO innovation is the safe attach probe tip feature. The quick lever lets tips be secured quickly and safely to the probe head without screwing and tools, preventing over-tightening of the SMA connector, which can damage the contact and degrade the signal and isolation performance. By omitting the need for direct contact to metal conductors, electrostatic discharges (ESD) on the sensitive probe tips and the probe head are prevented.

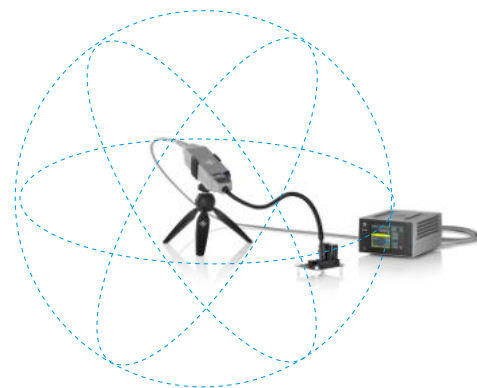
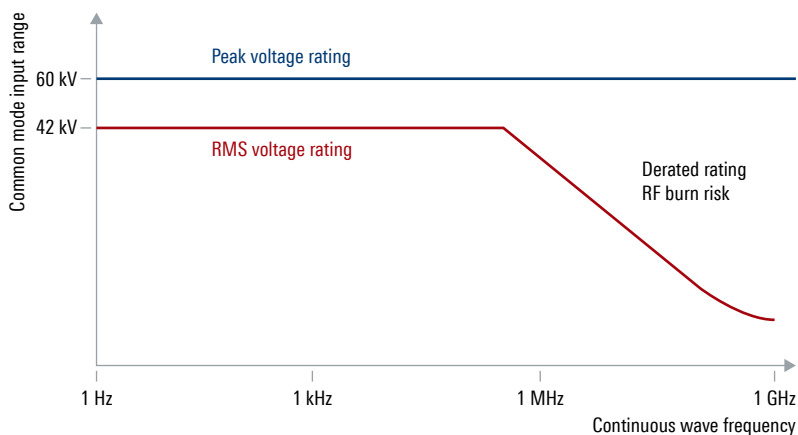

RF burn zone

At high frequencies, a viable electrical path for common mode voltage can be found over the air. Keeping a distance of 1 m around the probe head prevents possible RF burn when handling probes, when DUTs are expected to have high power and fast CM voltage.

Laser safety

The lasers provide power and share waveform information between the probe head and receiver. Laser safety is very important when operating the isolated probing system. R&S®RT-ZISO complies with IEC 60825-1 as a class 1 laser when in operation. The optical power transmission is also continuously monitored and switched off if the optical fiber might potentially be damaged.

Safety characteristics

Maximum rated input voltage	continuous voltage	1000 V (RMS) CAT III
	transient voltage (socket to ground)	±4500 V (peak)
Electrical safety		in line with IEC/EN61010-1, IEC/EN61010-031
Laser safety		in line with IEC 60825-1, class 1

ACCESSORIES

The R&S®RT-ZISO isolated probing system offers various accessories for different test setups. The probe head can be screwed by a bracket with a standard 1/4"-20 UNC socket to a standard camera tripod. They come standard with each probe system. The isolated passive probes also come with matching ground cables and hooks. When attaching additional probe tip adapters to the device under test, note the frequency derating and maximum input voltage tolerance.



R&S®ZISO-Z101/-Z201 MMCX probe tip



R&S®RT-ZAMXHTS



R&S®RT-ZAMXUFL

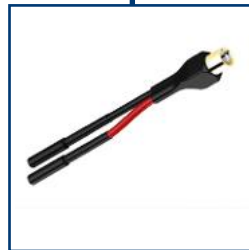

R&S®RT-ZAMXSQ



R&S®RT-ZAMXPAD

Model	Description	Temperature range
R&S®RT-ZAMXHTS	MMCX socket to solder-in cable HT	-40°C to +155°C
R&S®RT-ZAMXUFL	MMCX socket to UFL adapter	-40°C to +125°C
R&S®RT-ZAMXSQ	MMCX socket to dual square pin	-40°C to +125°C
R&S®RT-ZAMXPAD	MMCX socket to solder-in pad flex HT	-40°C to +155°C

SPECIFICATIONS IN BRIEF

R&S®RT-ZISO isolated probing system

Step response		
Rise time	10% to 90%	
	with R&S®ZISO-B901 option	< 4 ns
	with R&S®ZISO-B902 option or -B202 upgrade	< 2 ns
	with R&S®ZISO-B903 option or -B203 upgrade	< 1.14 ns
	with R&S®ZISO-B905 option or -B205 upgrade	< 800 ps
	with R&S®ZISO-B910 option or -B210 upgrade	< 450 ps
Flatness	starting 10 ns after edge	3% (meas.)
Propagation delay	incl. oscilloscope connector cable	
	with R&S®ZISO-B403 option (3 m optical fiber)	27 ns (meas.)
	with R&S®ZISO-B410 option (10 m optical fiber)	63 ns (meas.)

Frequency response		
Bandwidth	starting at DC, calculated from 0.45/rise time	
	with R&S®ZISO-B901 option	100 MHz
	with R&S®ZISO-B902 option or -B202 upgrade	200 MHz
	with R&S®ZISO-B903 option or -B203 upgrade	350 MHz
	with R&S®ZISO-B905 option or -B205 upgrade	500 MHz
	with R&S®ZISO-B910 option or -B210 upgrade	1 GHz
Flatness	1 kHz up to half of the system bandwidth	0.2 dB (meas.)
Common mode rejection (meas.)	DC	145 dB
	1 MHz	145 dB
	100 MHz	110 dB
	200 MHz	100 dB
	500 MHz	100 dB
	1 GHz	90 dB

Input impedance		
DC input resistance		1 M Ω \pm 1%
Input capacitance		8 pF (meas.)

DC characteristics		
Attenuation		0.04:1
	automatically set by oscilloscope vertical setting (supported by MXO series, R&S®RTO6 and R&S®RTP oscilloscopes with Rohde&Schwarz probe interface; manual settings required for SMA/BNC connections with 50 Ω coupling; can be attached to oscilloscopes with 1 M Ω input coupling using a BNC feedthrough termination adapter)	0.01:1
		0.2:1
		0.4:1
		2:1
		4:1
		20:1
		40:1
		120:1
Attenuation error	after self-alignment	
	input voltage range > \pm 0.01 V	\pm 1.5% full scale
	input voltage range \pm 0.01 V	\pm 2.5% full scale
Temperature drift, attenuation		\pm 0.15%/°C (meas.)
Zero error	after self-alignment (input related)	\pm 0.5 mV \pm 0.02 \times input voltage range

Dynamic range

Input voltage range	0.04:1	±0.01 V
	0.1:1	±0.025 V
	0.2:1	±0.05 V
	0.4:1	±0.1 V
	2:1	±0.5 V
	4:1	±1 V
	20:1	±5 V
	40:1	±10 V
	120:1	±30 V
Offset compensation range	in all attenuation settings applicable	±30 V
Offset compensation error		$\pm(0.35\% \times \text{offset} + 0.35\% \times \text{input voltage range})$ (meas.)
Operating voltage window	each signal socket to ground, not handheld, with 1 m protective distance to probe head	±60 kV
	handheld in combination with R&S®ZISO-Zxxx (excl. R&S®ZISO-Z301)	1000 V (RMS) CAT III
	handheld in combination with R&S®ZISO-Z301	300 V CAT II

System noise voltage (meas.)

measured with compatible Rohde & Schwarz oscilloscope (system noise depends on oscilloscope frontend)

Input voltage range	R&S®ZISO-B901 (100 MHz)	R&S®ZISO-B902 (200 MHz)	R&S®ZISO-B903 (350 MHz)	R&S®ZISO-B905 (500 MHz)	R&S®ZISO-B910 (1 GHz)
±0.01 V	107 µV	121 µV	153 µV	172 µV	245 µV
±0.025 V	140 µV	161 µV	220 µV	252 µV	383 µV
±0.05 V	211 µV	255 µV	363 µV	417 µV	623 µV
±0.1 V	382 µV	465 µV	683 µV	780 mV	1.16 mV
±0.5 V	1.84 mV	2.26 mV	3.35 mV	3.81 mV	5.65 mV
±1 V	5.90 mV	7.27 mV	9.49 mV	10.9 mV	16.0 mV
±5 V	18.9 mV	23.5 mV	34.3 mV	39.0 mV	58.5 mV
±10 V	37.0 mV	45.7 mV	67.4 mV	77.1 mV	115 mV
±30 V	110 mV	134 mV	201 mV	229 mV	342 mV

Maximum rated input voltage

Continuous voltage	derated, refer to manual, input inner and outer conductor to ground with R&S®ZISO-Zxxx (excl. R&S®ZISO-Z301)	1000 V (RMS) CAT III
	derated, refer to manual, input inner and outer conductor to ground with R&S®ZISO-Z301	300 V (RMS) CAT III
	derated, see figure below, input inner conductor to reference terminal without R&S®ZISO-Zxxx	30 V (RMS), 42.4 V (peak)
	DC voltage, input inner conductor to reference terminal without R&S®ZISO-Zxxx	±60 V

Maximum rated sine-wave RMS voltage between input contact and shielding versus frequency

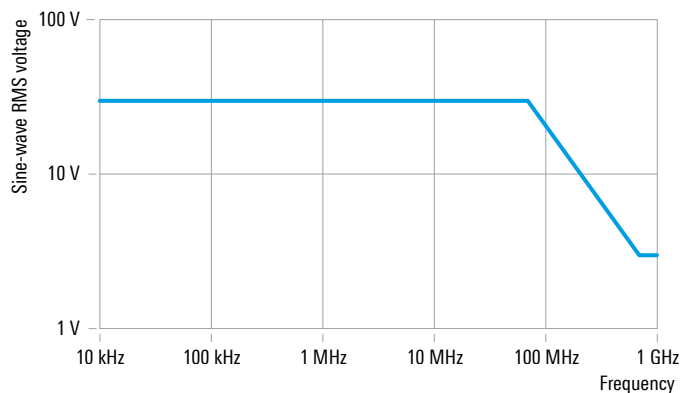

Base unit		
Input coupling	DC	50 Ω

R&S®ProbeMeter

Specifications for measurement error apply only when offset compensation setting is 0 V. The R&S®ProbeMeter can be used to measure differential voltages.

Measurement error		
DC coupling (meas.)	probe head only and with R&S®ZISO-Zxxx (excl. R&S®ZISO-Z302)	
	+15 °C to +35 °C	±0.2% of reading ± 0.01 V × tip attenuation
	0 °C to +40 °C	±0.4% of reading ± 0.02 V × tip attenuation
	with R&S®ZISO-Z302	
AC coupling (meas.)	+15 °C to +35 °C	±0.8% of reading ± 0.01 V × tip attenuation
	0 °C to +40 °C	±1.6% of reading ± 0.02 V × tip attenuation
	with R&S®ZISO-Z302	
	+15 °C to +35 °C	±0.4% of reading ± 0.01 V × tip attenuation
Temperature drift	0 °C to +40 °C	±1.6% of reading ± 0.02 V × tip attenuation
		0.02%/°C of reading ± 2 mV/°C (meas.)
50 Hz/60 Hz rejection		> 87 dB
Integration time		147 ms

General data

Temperature		
Temperature loading	operating temperature range	0 °C to +40 °C
	storage temperature range	-40 °C to +70 °C
Climatic loading		+25 °C/+40 °C cyclic at 95% relative humidity without condensation, in line with IEC 60068-2-30
Altitude	operation	up to 2000 m
	transport	up to 4500 m
EMC		in line with EMC Directive 2014/30/EC, IEC/EN 61326-1 (table 2), IEC/EN 61326-2-1, CISPR 11/EN 55011(class A)
Calibration interval		2 years
Safety		in line with IEC/EN 61010-1, IEC/EN 61010-031, IEC 60825-1
RoHS		in line with EN IEC 63000
External power supply		100 V to 240 V ± 10% at 50 Hz/60 Hz, max. 1.0 A or 1.4 A
Mechanical data		
Dimensions	probe head, without connectors and bend protection (W × H × L)	approx. 50 mm × 40 mm × 172 mm (1.97 in × 1.58 in × 6.77 in)
	probe receiver, without connectors and bend protection (W × H × L)	approx. 120 mm × 69 mm × 158 mm (4.72 in × 2.72 in × 6.22 in)
	length of optical fiber	
Weight	R&S®ZISO-B403 option	approx. 3 m (10 ft)
	R&S®ZISO-B410 option	approx. 10 m (33 ft)
Minimum bend radius of optical fiber	probe without accessories	approx. 1.5 kg (3.3 lb)
	probe with standard accessory (incl. bag)	approx. 3.2 kg (7.1 lb)
Probe interface		
Input socket		SMA (female)
Connector	via oscilloscope connector cable	Rohde&Schwarz probe interface
	without oscilloscope connector cable	SMA (female)

R&S® ZISO-Z10x and R&S® ZISO-Z20x probe tip modules

		R&S® ZISO-Z101	R&S® ZISO-Z201	R&S® ZISO-Z202	R&S® ZISO-Z203
Probe input					
Connector		MMCX (male)	MMCX (male)	SQPIN (2.54 mm, female)	WSQPIN (5.08 mm, female)
Step response					
Rise time	system, 10% to 90%	< 450 ps (meas.)			
Flatness	starting 10 ns after edge	2% (meas.)			
Frequency response					
Bandwidth	system, -3 dB, starting at DC	> 1 GHz (meas.)			
Flatness	1 kHz up to half of the system bandwidth	0.2 dB (meas.)			
Common mode rejection (meas.)	DC	145 dB	145 dB	129 dB	120 dB
	1 MHz	120 dB	105 dB	105 dB	98 dB
	100 MHz	100 dB	85 dB	47 dB	44 dB
	200 MHz	95 dB	80 dB	43 dB	40 dB
	500 MHz	95 dB	75 dB	30 dB	28 dB
	1 GHz	80 dB	60 dB	11 dB	8 dB
Input impedance					
DC input resistance	system	50 Ω ± 1%	10 MΩ ± 1%		40 MΩ ± 1%
Input capacitance	system	< -12 dB (meas.) ¹⁾	3.7 pF (meas.)	3.5 pF (meas.)	3.2 pF (meas.)
DC characteristics					
Attenuation	system	1.5:1	10:1	25:1	100:1
Attenuation error	system	±2%			
Maximum rated input voltage					
Continuous voltage	between probe tip and probe reference terminal	8 V (RMS)	300 V (RMS)	750 V (RMS)	2500 V (RMS)
	between probe terminals and earth ground; derated	1000 V (RMS) CAT III			
Transient voltage		±45 V (peak)	±500 V (peak) ²⁾	±1000 V (peak) ¹⁾	±3500 V (peak) ¹⁾
Dynamic range					
Input voltage range		±45 V	±300 V	±750 V	±3000 V

General data

Temperature			
Temperature loading	operating temperature range	0°C to +40°C	
Climatic loading		+25°C/+40°C cyclic at 95% relative humidity without condensation, in line with IEC 60068-2-30	
Altitude	operation	up to 2000 m	
Safety		in line with Low Voltage Directive 2014/35/EU, IEC 61010-1, IEC 61010-031, IEC 60825-1	
RoHS		in line with EN IEC 63000	
Mechanical data			
Dimensions	diameter of probe tip	approx. 5 mm (0.2 in)	
	cable length	R&S® ZISO-Z201	approx. 21.5 cm (8.5 in)
		R&S® ZISO-Z202	approx. 32 cm (12.6 in)
		R&S® ZISO-Z203	approx. 38 cm (15 in)
Weight	probe only	approx. 75 g (0.17 lb)	

¹⁾ R&S® ZISO-Z101 probe tip modules with 50 Ω DC input resistance are defined by reflection coefficient instead of capacitive loading.

²⁾ Between probe tip and probe reference terminal.

R&S® ZISO-Z30x probe tip modules

		R&S® ZISO-Z301	R&S® ZISO-Z302
Probe input			
Connector		browser	browser
Step response			
Rise time	system, 10% to 90%	700 ps (meas.)	900 ps (meas.)
Flatness	starting 10 ns after edge	2% (meas.)	
Frequency response			
Bandwidth	system, -3 dB, starting at DC	> 500 MHz (meas.)	
Input impedance			
DC input resistance	system	10 MΩ ± 1%	100 MΩ ± 1%
Input capacitance	system	11 pF (meas.)	4.6 pF (meas.)
DC characteristics			
Attenuation	system	10:1	100:1
Attenuation error	system	±2%	
Maximum rated input voltage			
Continuous voltage	between probe tip and probe reference terminal; derated	300 V (RMS)	3540 V (RMS)
	between probe terminals and earth ground; derated	300 V (RMS) CAT III	1000 V (RMS) CAT III
Dynamic range			
Input voltage range		±300 V	±3000 V

General data

Temperature			
Temperature loading	operating temperature range	0°C to +40°C	
Climatic loading		+25°C/+40°C cyclic at 95% relative humidity without condensation, in line with IEC 60068-2-30	
Altitude	operation	up to 2000 m	
Safety		in line with Low Voltage Directive 2014/35/EU, IEC 61010-1, IEC 61010-031, IEC 60825-1	
RoHS		in line with EN IEC 63000	
Mechanical data			
Dimensions	diameter of probe tip	approx. 5 mm (0.2 in)	
	diameter of probe reference terminal	approx. 2 mm (0.08 in)	
	cable length	approx. 1.2 m (47 in)	
Weight	probe only	approx. 75 g (0.17 lb)	

ORDERING INFORMATION

Designation	Type	Order No.
Probe configuration, base model		
Isolated probing system, ± 30 V, 1 kV (RMS) CAT III (depending on tip module), Rohde & Schwarz probe interface and BNC Incl. carrying case; operating manual	R&S®RT-ZISO	1804.5000K02
Choose your cable length		
Optical fiber, length: 3 m	R&S®ZISO-B403	1804.5017.02
Optical fiber, length: 10 m	R&S®ZISO-B410	1804.5023.02
Choose your system bandwidth		
100 MHz option	R&S®ZISO-B901	1804.5030.02
200 MHz option	R&S®ZISO-B902	1804.5046.02
350 MHz option	R&S®ZISO-B903	1804.5052.02
500 MHz option	R&S®ZISO-B905	1804.5069.02
1 GHz option	R&S®ZISO-B910	1804.5075.02
Choose your probe tips		
MMCX 1.5:1, 50 Ω , tip module for R&S®RT-ZISO, 8 V (RMS), ± 45 V (peak), 1 kV (RMS) CAT III	R&S®ZISO-Z101	1803.4100.02
MMCX 10:1, 10 M Ω , tip module for R&S®RT-ZISO, ± 300 V (peak), 1 kV (RMS) CAT III	R&S®ZISO-Z201	1803.4200.02
SQPIN 25:1, 10 M Ω , tip module for R&S®RT-ZISO, ± 750 V (peak), 1 kV (RMS) CAT III	R&S®ZISO-Z202	1803.4300.02
WSQPIN 100:1, 40 M Ω , tip module for R&S®RT-ZISO, ± 3 kV (peak), 1 kV (RMS) CAT III	R&S®ZISO-Z203	1803.4400.02
Browser 10:1, 10 M Ω , tip module for R&S®RT-ZISO, ± 300 V (peak), 300 V (RMS) CAT III	R&S®ZISO-Z301	1803.4500.02
Browser 100:1, 100 M Ω , tip module for R&S®RT-ZISO, ± 3 kV (peak), 1 kV (RMS) CAT III	R&S®ZISO-Z302	1803.4600.02
Bandwidth upgrade		
200 MHz upgrade	R&S®ZISO-B202	1804.5146.02
350 MHz upgrade	R&S®ZISO-B203	1804.5152.02
500 MHz upgrade	R&S®ZISO-B205	1804.5169.02
1 GHz upgrade	R&S®ZISO-B210	1804.5175.02
Choose your accessories		
MMCX socket to dual square pin	R&S®RT-ZAMXSQ	1803.1647.02
MMCX socket to U.F.L adapter	R&S®RT-ZAMXUFL	1803.1676.02
MMCX socket to solder-in cable HT	R&S®RT-ZAMXHTS	1803.1660.02
MMCX socket to solder-in pad flex HT	R&S®RT-ZAMXPAD	1803.1653.02

Pre-package model with isolated probes

Type	Consists of:	Order No.
R&S®RT-ZISO01	100 MHz isolated probe package with 3 m length, includes R&S®ZISO-Z301 probe tip	1804.5000P11
R&S®RT-ZISO01L	100 MHz isolated probe package with 10 m length, includes R&S®ZISO-Z301 probe tip	1804.5000P21
R&S®RT-ZISO02	200 MHz isolated probe package with 3 m length, includes R&S®ZISO-Z301 probe tip	1804.5000P12
R&S®RT-ZISO02L	200 MHz isolated probe package with 10 m length, includes R&S®ZISO-Z301 probe tip	1804.5000P22
R&S®RT-ZISO03	350 MHz isolated probe package with 3 m length, includes R&S®ZISO-Z301 probe tip	1804.5000P13
R&S®RT-ZISO03L	350 MHz isolated probe package with 10 m length, includes R&S®ZISO-Z301 probe tip	1804.5000P23
R&S®RT-ZISO05	500 MHz isolated probe package with 3 m length, includes R&S®ZISO-Z301 probe tip	1804.5000P14
R&S®RT-ZISO05L	500 MHz isolated probe package with 10 m length, includes R&S®ZISO-Z301 probe tip	1804.5000P24
R&S®RT-ZISO10	1 GHz isolated probe package with 3 m length, includes R&S®ZISO-Z201 and R&S®ZISO-Z301 probe tips	1804.5000P15
R&S®RT-ZISO10L	1 GHz isolated probe package with 10 m length, includes R&S®ZISO-Z201 and R&S®ZISO-Z301 probe tips	1804.5000P25

Service at Rohde & Schwarz

YOU'RE IN GREAT HANDS

	SERVICE PLANS	ON DEMAND
Calibration	Up to five years ¹⁾	Pay per calibration
Warranty and repair	Up to five years ¹⁾	Standard price repair

¹⁾ For extended periods, contact your Rohde & Schwarz sales office.

Instrument management made easy

The R&S®InstrumentManager makes it easy to register and manage your instruments. It lets you schedule calibration dates and book services.

Find out more
about our service
portfolio under:



Service at Rohde & Schwarz
You're in great hands

- ▶ Worldwide
- ▶ Local and personalized
- ▶ Customized and flexible
- ▶ Uncompromising quality
- ▶ Long-term dependability

Rohde & Schwarz

The Rohde & Schwarz technology group is among the trailblazers when it comes to paving the way for a safer and connected world with its leading solutions in test & measurement, technology systems and networks & cybersecurity. Founded more than 90 years ago, the group is a reliable partner for industry and government customers around the globe. The independent company is headquartered in Munich, Germany and has an extensive sales and service network with locations in more than 70 countries.

www.rohde-schwarz.com

Sustainable product design

- ▶ Environmental compatibility and eco-footprint
- ▶ Energy efficiency and low emissions
- ▶ Longevity and optimized total cost of ownership

Certified Quality Management

ISO 9001

Certified Environmental Management

ISO 14001

Rohde & Schwarz training

www.training.rohde-schwarz.com

Rohde & Schwarz customer support

www.rohde-schwarz.com/support

