

4 Channel
Power Meter

LMG450

User manual

© Copyright 2021

ZES ZIMMER Electronic Systems GmbH

Pfeiffstraße 12

D-61440 Oberursel (Taunus), FRG

phone ++49 (0)6171 888320

fax ++49 (0)6171 8883228

e-mail: sales@zes.com

Internet: <http://www.zes.com>

No part of this document may be reproduced, in any form or by any means, without the permission in writing from ZES ZIMMER Electronic Systems GmbH.

Regard DIN 34!

We reserve the right to implement technical changes at any time, particularly where these changes will improve the performance of the instrument.

Konformitätserklärung

Declaration of Conformity

für das

for the

4-Kanal-Leistungsmessgerät

4-Channel Power Analyzer

LMG450

Hiermit wird bestätigt, dass das oben aufgeführte Gerät den Anforderungen der Richtlinien 2014/30/EU, 2014/35/EU, 2012/19/EU und 2011/65/EU + 2015/863/EU der Europäischen Union entspricht.

We certify that the above device accomplishes with all requirements which are defined in the directives 2014/30/EU, 2014/35/EU, 2012/19/EU and 2011/65/EU + 2015/863/EU of the European Union.

Diese Erklärung gilt für alle Geräte, die nach anhängenden Fertigungsunterlagen - die Bestandteil dieser Erklärung sind - hergestellt werden.

This certificate is valid for all devices that are produced according to the appending production instructions (which are a part of this certificate).

Zur Beurteilung wurden folgende Normen herangezogen:

For the judgment of compatibility of the product the following standards were used:

EN IEC61000-3-2:2019+A1:2021

EN61000-3-3:2013+A1:2019

EN55011:2016+A1:2017+A11:2020+A2:2021

EN IEC61326-1:2021

EN61010-1:2010+A1:2019, EN IEC61010-2-030:2021+A11:2021

EN50581:2012

Diese Erklärung wird vom Hersteller

This certificate of the manufacturer

ZES ZIMMER Electronic Systems GmbH
Pfeiffstraße 12
D-61440 Oberursel

abgegeben durch

is given by

Dr. Conrad Zimmer, Geschäftsführer

Oberursel, 16. August 2021

Dr. Conrad Zimmer, Geschäftsführer

Manufacturer Declaration

ZES ZIMMER Electronic Systems GmbH certifies herewith that the instrument to which this declaration belongs to is in compliance with all specifications contained in the delivered user manual. It has left the factory in mechanically and electrically safe condition.

The measuring instruments, tools and standards used in production, adjustment and calibration are calibrated according to ISO9000 (traceable to national standards) and correspond to the standard of precision required to maintain the specified uncertainties.

ZES ZIMMER

Pfeiffstraße 12
D-61440 Oberursel
Germany

Table of contents

1	Instructions and Warnings	19
1.1	Safety Instructions	19
2	General	27
2.1	Features and application areas.....	27
2.2	Usage of the manual.....	28
2.3	General handling of the instrument.....	29
2.4	The group concept	31
2.5	Linked values, star to delta conversion (option L45-O6)	35
3	Installation	41
3.1	Unpacking and putting into operation.....	41
3.2	General set-up.....	41
3.3	Connections of the LMG450.....	41
3.3.1	Measuring circuit for typical line applications using the internal current path	42
3.3.2	Measuring circuit for measuring efficiency of 3/1phase systems.....	43
3.3.3	Measuring circuit (typical) for star to delta conversion (option L45-O6)	44
3.3.4	Aron wiring	45
3.3.5	Measuring circuit for measuring efficiency of 3/3phase systems.....	46
3.3.6	Measuring circuit using an external current sensor.....	46
3.3.7	Measurement of high currents	47
3.3.8	Measurements at middle and high voltage systems	48
3.3.9	Measurements at middle and high voltage systems without N.....	49
3.3.10	Measurements at middle and high voltage systems without N.....	50
4	Instrument controls	51
4.1	Front panel.....	51
4.2	Rear panel	52
4.3	Display	54
4.3.1	Status line.....	54
4.4	General menus	55
4.4.1	Misc.	55
4.4.2	IF/IO	57
4.4.3	Custom menu.....	63
4.4.4	Script/Formula editor.....	64
4.4.5	Saving and restoring configurations	74
4.5	Entering identifiers, characters and text.....	74
4.6	Entering numerical values	79
5	Normal measuring mode.....	81
5.1	Measuring configuration (Measuring).....	81
5.1.1	Globals tab	81
5.1.2	Group A/B tab.....	82

5.2 Measuring ranges (Range)	85
5.2.1 Group A/B tab.....	85
5.2.2 Sense/More tab.....	86
5.3 Definition of measuring values	87
5.3.1 Values from single measuring.....	91
5.3.2 Integrated values.....	93
5.3.3 Total values	94
5.4 Display of values	95
5.4.1 Default	96
5.4.2 Voltage.....	97
5.4.3 Current.....	97
5.4.4 Power.....	97
5.4.5 Energy.....	98
5.4.6 Graphical display	99
5.4.7 Custom menu.....	105
5.5 Storage of values	105
6 prCE-Harmonic measuring mode	107
6.1 Measuring configuration (Measuring).....	107
6.1.1 Global tab.....	107
6.1.2 Group A/B tab.....	108
6.2 Measuring ranges (Range)	109
6.3 Definition of measuring values	109
6.4 Display of values	110
6.4.1 Default	111
6.4.2 Voltage.....	111
6.4.3 Current.....	111
6.4.4 Power.....	112
6.4.5 Long time evaluation	112
6.4.6 Graphical display	113
6.4.7 Custom menu.....	115
6.5 Storage of values	115
6.6 Precompliance tests according EN61000-3-2	115
7 CE-Flicker measuring mode (option L45-O4)	117
7.1 Measuring configuration (Measuring).....	117
7.1.1 Globals tab	117
7.1.2 Ztest/Zref tab.....	118
7.2 Measuring ranges (Range)	118
7.3 Definition of measuring values	118
7.4 Display of values	119
7.4.1 Default	119
7.4.2 Voltage.....	120
7.4.3 Current.....	120
7.4.4 Power.....	120
7.4.5 Flicker (Int. Val).....	120
7.4.6 Graphical display	121

7.4.7 Custom menu.....	121
7.5 Storage of values	121
7.6 Tests according EN61000-3-3.....	121
8 100 Harmonics measuring mode (option L45-O8)	123
8.1 Measuring configuration (Measuring).....	123
8.2 Measuring ranges (Range)	124
8.3 Definition of measuring values	124
8.4 Display of values	125
8.4.1 Default	126
8.4.2 Voltage.....	126
8.4.3 Current	126
8.4.4 Power.....	126
8.4.5 Graphical display	127
8.4.6 Custom menu.....	127
8.5 Storage of values	127
9 Transient mode (option L45-O5)	129
9.1 Measuring configuration (Measuring).....	129
9.1.1 Globals tab	129
9.1.2 GroupA/B tab.....	129
9.2 Measuring ranges (Range)	132
9.3 Display of values	132
9.3.1 Graphical display	132
9.4 Storage of values	132
10 Interfaces (IEEE option L45-O1).....	133
10.1 Short syntax description	133
10.2 Commands.....	135
10.2.1 IEEE488.2 common commands	135
10.2.2 :CALCulate commands	139
10.2.3 :DISPlay commands.....	144
10.2.4 :FETCh and :READ commands	144
10.2.5 :FORMat commands.....	182
10.2.6 :INITiate commands	183
10.2.7 :INPut commands	185
10.2.8 :INSTrument commands	185
10.2.9 :MEMory commands	186
10.2.10 :SENSE commands	187
10.2.11 :SOURce commands.....	208
10.2.12 :STATus commands.....	210
10.2.13 :SYSTem commands.....	214
10.2.14 :TRIGger commands.....	220
10.2.15 Special commands.....	225
10.2.16 Example 1	226
10.2.17 Example 2.....	227
10.2.18 Testing the interface using a terminal program.....	227

10.2.19 SCPI command Example.....	228
10.2.20 SHORT command Example	230
10.3 Physical devices.....	232
10.3.1 The serial interfaces	232
10.3.2 IEEE488.2.....	233
10.3.3 Parallel Port.....	234
11 Logging of values to drives, printer and interfaces	235
11.1 Start of logging	235
11.2 End of logging	236
11.3 Logging profiles (output devices).....	236
11.3.1 Output intervals	237
11.4 Output formats	238
11.5 Remarks, header lines	239
11.6 Storage media	240
11.6.1 Floppy disk drive	240
11.6.2 Memory card drive.....	240
11.6.3 USB memory stick.....	241
11.7 Import of data into PC programs	241
11.7.1 Data exchange via storage media.....	241
11.7.2 Data exchange via serial interface.....	242
11.7.3 Country dependent numbers.....	242
11.7.4 Reading data into EXCEL.....	242
11.8 Error messages.....	243
12 Miscellaneous	245
12.1 Frequently asked questions	245
12.1.1 Uncertainty of measured and computed values	245
12.1.2 Uncertainty of non sinusoidal signals.....	248
12.2 Function fault.....	249
12.3 Maintenance	254
12.3.1 Calibration	254
12.3.2 Adjustment	255
12.3.3 Zero adjustment of the instrument.....	255
12.3.4 Fans.....	255
12.3.5 Battery.....	256
12.3.6 Software update.....	256
12.4 Use with an inverter.....	256
13 Technical data	257
13.1 General	257
13.2 Display of values	258
13.3 Measuring channels	259
13.3.1 Sampling.....	259
13.3.2 Ranges.....	259
13.3.3 Uncertainty	261

13.3.4 Special transformer adjustment (L45-O12).....	262
13.3.5 Modified voltage channel for 1kV input (L45-O15).....	262
13.4 ZES current sensors	263
13.5 Filter	263
13.5.1 HF Rejection filter	263
13.6 prCE Harmonics	264
13.7 CE Flicker	264
13.8 HARM100 Mode.....	265
13.9 Processing signal interface (option L45-O3).....	265
13.9.1 Analogue inputs.....	267
13.9.2 Analogue outputs.....	267
13.9.3 Digital inputs	267
13.9.4 Frequency inputs.....	267
13.9.5 Digital outputs	267
13.9.6 Auxiliary supply.....	268
13.9.7 Frequency/direction input.....	268
13.10 Timebase	268
13.11 Frequency measuring	268
13.12 Scope memory	268
14 System design.....	269
14.1 Further connectors	269
14.1.1 External Synchronisation (Sync.)	269
14.1.2 External Current Sensor.....	273
14.2 Functional block diagram LMG450.....	274
14.3 Functional block diagram voltage channels.....	275
14.4 Functional block diagram current channels.....	276
14.5 Functional block diagram computing unit	277
14.6 Functional block diagram processing signal interface	278
15 Glossary.....	279
16 Common Index	291
17 Interface command index	311

List of figures

Figure 1: Measuring menu	29
Figure 2: Allocations of the different linked values.....	35
Figure 3: Measuring circuit 3 phase system with neutral.....	42
Figure 4: Measuring circuit for measuring efficiency (3/1phase)	43
Figure 5: Star to delta conversion	44
Figure 6: Measuring circuit with current and voltage transformers in Aron wiring	45

Figure 7: Measuring circuit for measuring efficiency (3/3phase)	46
Figure 8: Measuring circuit with external current sensor	46
Figure 9: Measuring circuit for measuring high currents with transformers, voltage directly ..	47
Figure 10: Measuring circuit for measuring in middle and high voltage systems.....	48
Figure 11: Measuring circuit for measuring in middle and high voltage systems without N Using artificial midpoint.....	49
Figure 12: Measuring circuit for measuring in middle and high voltage systems without N Using star to delta conversion	50
Figure 13: Front panel of the instrument	51
Figure 14: Rear panel of the instrument.....	52
Figure 15: Status lines with 3 different wirings.....	54
Figure 16: Misc. menu	56
Figure 17: Interface Setup	57
Figure 18: Analogue inputs.....	60
Figure 19: Analogue outputs.....	60
Figure 20: Digital inputs	61
Figure 21: Limit menu	62
Figure 22: Script editor.....	64
Figure 23: Measuring menu in normal mode.....	85
Figure 24: Range menu.....	85
Figure 25: Allocation of the different linked values.....	88
Figure 26: Default display with one and four channels.....	97
Figure 27: Scope display with split off/on	101
Figure 28: The plot display; split off.....	101
Figure 29: The plot display; split on	103
Figure 30: Vector (Fresnel) diagramm	104
Figure 31: Measuring menu in prCE-Harm mode	108
Figure 32: Display of voltages in prCE-Harm mode	111
Figure 33: Long time evaluation of harmonics.....	113
Figure 34: Graphical display of harmonics.....	114
Figure 35: Measuring menu in CE-Flicker mode	118
Figure 36: Evaluation of flicker measurement.....	120
Figure 37: Measuring menu in Harm100 mode.....	123
Figure 38 Measuring menu in transient mode	130
Figure 39: Keynumbers.....	218
Figure 40: COM A connector	233
Figure 41: COM B connector	233
Figure 42: Dimensions of LMG450.....	258
Figure 43: Processing Signal Interface Connector	266
Figure 44: Sync. connector	269
Figure 45: External current sensor connector	273

Figure 46: Functional block diagram LMG450..... 274
Figure 47: Functional block diagram voltage channels..... 275
Figure 48: Functional block diagram current channels 276
Figure 49: Functional block diagram computing unit..... 277
Figure 50: Functional block diagram processing signal interface..... 278

1 Instructions and Warnings

1.1 Safety Instructions

This instrument conforms to the IEC61010-1 guide lines concerning the protection of electrical instrumentation and has left the factory in a mechanically and electrically safe condition. To maintain safe operation, the user must follow the instructions and warnings contained in this manual. The instrument satisfies the requirements of **protection class I** (protective earthing). Accessible metal parts of the instrument are tested with respect to the mains connection using a potential of 1500V/50Hz. Before connecting the apparatus to the mains supply, ensure that the voltage displayed on the type plate equals the available mains supply voltage. A possibly installed power supply selector has to be set up. The mains plug must only be connected to an earthed mains outlet. The earth connection must not be discontinued or broken by using an extension lead without earth connection. The instrument must be connected to the mains supply before any measurement or control circuits are connected to it. Any disconnection of the earth lead inside or outside of the instrument will endanger the operating personal. Deliberate disconnection of the earth is not permitted. When the instrument is used in combination with other instruments, then proceed as follows:

The external earth connector on the back of the instrument must not be used to earth other electrical equipment. It is only intended to provide additional earthing of the instrument in case an error occurs in the circuit under test which may cause an earth current to flow in excess of 10A which cannot be carried by the mains supply cable. If this further earthing cannot be implemented, then the measuring circuit must be suitably fused prior to its connection to the instrument. In this case, it is necessary to connect the measuring instrument to an earth connection point via the earth connector using a conductor with sufficient cross section. If this is not possible, the instrument has to be connected to the circuit to be tested via adequate fuses. The measuring inputs are isolated to case for operating voltages up to 600V according to protection class I.

By opening the instrument components are exposed which may be raised to a hazardous potential. All voltage sources must be disconnected from the instrument before any instrument covers are removed for the purpose of calibration, service, repair or changing components. When access is required for calibration, service or repair, only suitably qualified personnel are permitted access to an opened and energised instrument.

Fuses may only be replaced with the same ratings and the same types. The use of repaired or short circuited fuses is not permitted. The instrument should be disconnected and disabled from accidental use when it is suspected that its safe operation cannot be warranted. The required

repair work must then be carried out by a suitably qualified person who is familiar with any dangers involved.

It must be considered unsafe to operate the instrument:

- if there is visual evidence of physical damage
- if the instrument fails to operate correctly
- after long-term storage under unfavourable circumstances
- if there are condensation forms due to excessive temperature changes
- following rough transport conditions

If the instrument was opened, a high voltage test according to the technical data and a test of the protective conductor are necessary following the closing of the instrument.

Storage temperature range: -20°C to $+55^{\circ}\text{C}$

Climatic class: KYG according to DIN 40040
 $0^{\circ}\text{C}..40^{\circ}\text{C}$, humidity max. 85%, annual average 65%, no dewing

General



Warning!

Opening the instrument exposes components which contain high voltage. *This is only permitted by trained personnel. User risks injury by removing cover and may void any manufacturer 's warranty.* All voltage sources must be disconnected from the instrument before any instruments covers are removed. Only suitably qualified personnel are permitted such access for the purpose of calibration, service, repair or changing of components.

If the instrument has been opened, a routine test according to EN61010-1 (test of the protective conductor and voltage test) are necessary following the closing of the instrument for safety purposes prior to use.



Warning!









Fuses may only be replaced with the correctly rated and required types as written in this manual. The use of repaired, short-circuited or incorrect fuses is not permitted.



Warning!

The environmental conditions must be observed to ensure safe operation of the instrument.

Use in any type of wet or explosive environment or in presence of flammable gases or liquids is especially prohibited.

-  **Warning!** The instrument and accessories (such as wires and clips) must be checked before each use. Defective parts must be replaced.
-  **Warning!** Ventilation openings must be kept clear to guarantee the required air flow and to prevent overheating of the instrument. In the same way, the air filter at the air inlets must be clean to permit sufficient air flow. Do not operate the instrument without air filter or the filter holder as injury may result.
- When mounting the instrument into a rack, make sure that the slide rails do not cover any ventilation openings.
-  **Warning!** The instrument must not be used in a medical environment nor in any other environment that may have a potential effect on life or health.
-  **Warning!** Impacts or rough handling may damage the instrument. Do not place heavy objects on the instrument.
-  **Warning!** If the weight of the instrument is too heavy to be carried by one person, carry the instrument with two persons and/or use an appropriate tool. In all cases, use the handles and grips of the instrument to lift and carry it safely.
-  **Warning!** The instrument is *not* designed to detect hazards or something similar! A wrong reading (e.g. by choosing a wrong filter or range) could give you the wrong impression of a safe state. Use only tools which were designed for this purpose (e.g. a voltage detector) instead of this instrument to detect dangerous situations.
-  **Warning!** Be careful when connecting external equipment like an external keyboard or mouse to the instrument. They might not be designed to operate in the same EMC environment as the instrument and therefore they could be disturbed. This could lead to unwanted operation of the instrument like changing ranges or something similar.
-  **Warning!** When connecting the instrument watch the order of connections: First connect it to the protective conductor and the power supply, then connect it to the measurement circuit. Then switch on the instrument, and finally, after double checking the wiring, switch on the measurement circuit.

Connection to power supply and protective conductor



Attention! Before connecting the mains cable to the power supply, confirm that the mains supply voltage corresponds to the voltage printed on the model 's identification plate. If a voltage selector switch exists, it must be set appropriately. A suitable power source has to be used to operate the instrument.



Warning! The mains plug may only be inserted into a mains power supply socket with protective earth contact. This protection must not be disabled by the usage of plugs, cables or extension cords without protective earth.

The mains plug must be inserted into a mains socket with protective conductor *before* any other connections are made to the instrument. Any kind of interruption of the protective conductor, inside or outside the instrument, or disconnecting the protective conductor can result in an unsafe condition of the instrument and is not allowed. The usage of cables, plugs, sockets or adapters with only two poles, prongs or connectors is not allowed.

The *additional* protective conductor terminal of the instrument chassis (green/yellow safety jack on the back of the instrument) must be used for the case where an earth current in excess of 10 A might result accidentally from the circuit under test.

Such currents are too large for the earthing connection of the instrument supply cord. In case of a single fault, the protective conductor might not be able to carry this current. If it would be interrupted, the case would no longer be protected against electric shock!

In this case, connect the additional protective conductor terminal with an adequately rated cable to a suitable earthing point. The additional protective conductor terminal is limited to currents up to 32A.

If reliable earthing cannot be realized, the connections between the circuit under test and the instrument must be fused appropriately.

The earth terminal on the instrument must not be used as the only earth connection for the instrument nor must the circuit under test nor any other instrument be earthed by this terminal.

Connection to measurement circuit



Attention! Remove all energy source from the measurement circuit before making any connections between this circuit and the analyzer. Do not plug or disconnect any cables when they contain or carry voltage relative to earth.



Attention! Use only measurement cables with safety connectors and sufficient cross section. Be sure that the cables have a sufficient voltage rating and are usable for the desired overvoltage and measurement category.

Cables not having safety but standard connectors might have insufficient clearance and creepage distances, even if they are plugged into the socket. So there is always a risk of a electric shock.

Use only colored cables which match to the color of the jack to help prevent a wrong connection.

When connecting the measurement circuit, take special care not to connect the voltage wires to the current input of the instrument. When switching the measurement circuit on, this would result in a short circuit which risks damage to the analyzer and to the user!

Such short circuits can be very dangerous, as currents of several thousand ampere might flow during the short circuit!

To prevent this use *only* cables with suitable fuses as the ones delivered together with the instrument for the connection of the voltage measurement circuit to the instrument.

The fuses in the voltage measurement cables will interrupt the current flow for the case that these cables are accidentally inserted into the low ohmic current measurement jacks. By this short circuiting of a source with high short circuit power and/or measurement category (e.g.the output of a energy distribution transformer) will not cause any hazard.

The yellow and black voltage cables have each an implemented fuse. Before and after each measurement: Check the fuse! To replace this fuse, remove the cable on both sides from all circuits to make it free of dangerous voltages. Unscrew the fuse holder. Replace the fuse only with following type:

6.3x32mm, FF 500mA, 1000V AC+DC, 30kA breaking capacity

Screw the fuse holder together again.

**Attention!**

When connecting to a source with high short circuit power and/or measurement category (e.g. the output of an energy distribution transformer), massive damage could occur when mismatching cables, short-circuiting the measurement circuit, or using the current jacks of the instrument instead of the voltage jacks and similar. So it is recommended to use appropriate fuses in *all* (also the current) measurement cables. When selecting a fuse, ensure that at least the following properties are met:

- The usual measuring current must flow without interruption (rated current of the fuse)
- The short circuit current of the measurement circuit must be interrupted safely (breaking capacity of the fuse)
- The maximum voltage of the measurement circuit must be interrupted safely (rated voltage of the fuse)
- The fuse must be suitable for the type of current: AC, DC or both (breaking capacity of the fuse)
- The fuse must be fast enough to protect the cables and the instrument

**Attention!**

The maximum voltages between the jacks **U** and **U*** may not exceed the technical specifications.

**Attention!**

The maximum currents at the jacks **I** and **I*** as well as the maximum voltage between the jacks **I** and **I_{Sensor}** may not exceed the technical specifications.

**Attention!**

The maximum voltages of the jacks **U**, **U***, **I**, **I***, and **I_{Sensor}** against earth may not exceed the technical specifications

**Attention!**

The maximum voltages of the jacks **U**, **U*** against **I**, **I*** and **I_{Sensor}** may not exceed the technical specifications

**Attention!**

External current sensors or transformers with 1 A or 5 A secondary current must be connected to the jacks **I** and **I*** only. External devices with higher secondary currents are not allowed, because they could overload the measurement channel and interrupt the current! Also fuses are not allowed in the measurement cables.

Before using these jacks, test if they have a low impedance current path to prevent high voltages at the output of the external device.

In general, it is dangerous to interrupt the secondary side of a current transformer as there might appear very high voltages which could lead to electric shock.

For transformers with 1 A or 5 A secondary current, the jacks **I** and **I*** can carry sufficient overload current and will not be interrupted by usual overload.

**Attention!**

Cables from/to external sensors are usually designed to operate with low voltages (<10V). When using these in an environment with a high voltage circuit, use caution as further isolation might be necessary. For the operation itself the isolation is sufficient, but if these cables touch a bare conductor with dangerous voltages this can cause an unsafe condition! In such cases, further isolation might be necessary.

For example, the secondary cables of a current clamp have a very low voltage, but they could touch the current bar which has a dangerous voltage against earth.

**Attention!**

Especially when establishing external connections, special care must be taken to prevent electrostatic discharge.

**Attention!**

Different sensors might require different connection cables to the instrument. When changing a sensor, please ensure that a correct cable is used. Usually the cable is dedicated to a sensor.

**Attention!**

Keep away from energized measurement circuits to prevent electric shock. When performing measurements on installations or circuits, please observe all safety regulations and guidelines. In particular, only suitable measurement accessories should be used. Only suitably qualified personnel are permitted to work with energized measurement circuits.

**Attention!**

When you put the instrument out of operation, all external cables shall be removed. Special care has to be taken when disconnecting current sensors and current transformers. Before interrupting their secondary current, the primary current has to be switched off. After disconnecting, the secondary side, the current sensors or current transformer has to be short-circuited to prevent dangerous voltages.

2 General

The 4 Channel Power Meter LMG450 extends the ZES multimeter product range for power measurement. It benefits from experience and know-how gained from the successful ZES LMG90, LMG95 and LMG310 series.

Due to the high sampling rate which is used in this instrument, it is now possible to make accurate power and efficiency measurements in 1 to 4 phase system configurations with a variety of load and signal components containing frequencies in the precision range from DC to 20kHz.

Monitoring and storing transients, harmonic analysis as well as time domain views of signals' waveform on the graphical display (oscilloscope mode) are all available with this instrument.

A special feature of the instrument is the simple, direct and intuitive topology of the operating buttons. The display of different quantities and menus for setting up the instrument is normally achieved with only a single touch of one button.

2.1 Features and application areas

Voltages and currents can be measured over a wide dynamic range. This makes the LMG450 instrument suitable for almost all professional measurement applications such as converter-fed alternating current machines and power- and energy electronic applications. Various wire- and phase configurations can be pre-selected to suit any required user application.

Another feature of the instrument is to suppress high frequency harmonics by means of selectable filters. This makes it possible to take only the fundamental harmonics into account, which build the torque and the mechanical power at the motor output.

Due to the exceptionally good common mode rejection of each current/voltage input channel it is possible to measure currents and voltages which float up to 600V and at high frequencies with respect to earth. This is particularly important for measurements in inverter- and rectifier circuitry and in switched mode power supply applications.

The harmonics measuring mode (standard in the base instrument) permits the precompliance measurement of high frequency harmonic reflections in networks according to IEC61000-3-2 standard.

The extended harmonic mode up to the 99th available as option provides to obtain the energy distribution over different frequency ranges and can thus investigate their relative contribution to the total consumption of energy.

The LMG450 is suitable for measurements in electromagnetically noisy environments to IEC61000-4. This feature is of particular importance for measurements in power electronics.

Other applications include the measurement of reactive and non-linear component losses (such as in transformers, chokes, motors, capacitors, power supplies), the computation of the efficiencies of photovoltaic modules and other alternative energy components. Further on you can calculate energy and charge, e.g. of accumulators.

A further highlight are the special ZES ZIMMER current clamps. This unique accessories combine both, the easy usage of clamp-on current transformers with the small uncertainty of fix installed current transformers with primary winding for small currents from 0.1A to 80A. They are compensated for very small uncertainties for amplitude and phase over frequency. So they can be used in power measurement in a wide current and frequency range. With them you can measure with power!! uncertainties up to 0.3% in the frequency range 5Hz to 20kHz. So it is possible to measure the output of a PWM inverter without interrupting the wires.

2.2 Usage of the manual

The LMG450 is operated either by pressing buttons with hard-wired functions (in the following characterised by *italic* style), or by using softkeys (**bold** style) which will perform tasks that depend on a particular menu choice. This approach makes it possible to call all functions using a limited number of buttons without a need to call double or triple functions with one button. There are no menu trees so that the user does not need to fight his way through a menu jungle in order to call a particular display. Each menu can be called by simply pressing a single button.

The upper 6 buttons of the numerical keypad (*Default, Current, Voltage, Power, Int. Value and Graph*) enable the display of the standard measuring values by simply pressing a single button. In this menu a specified selection of the respective measuring values can be displayed using the soft keys.

The menus for the parameter set-up is called via the lower 6 buttons of the numerical keypad (*Measuring, Int. Time, Custom, Range, Misc., IF/IO,*). Thereby, all the instrument parameters can be adjusted using the soft keys.

Despite the simple and intuitive operation of the controls, it is recommended that even experienced users should carefully read and work through this manual to eliminate operational mistakes and to explore the full capability of the instrument.

There are following measuring modes:

- normal mode

In this mode the LMG450 works as a power-meter with integrated scope function. The

TRMS values of voltage and current, the power and derived values are measured via the power measuring channels.

- prCE harmonics mode

In this mode the LMG450 works as an harmonic analyser. All measurements are judged according to the standards. There is only a minimum of settings to prevent set-up errors. This mode can only be used for precompliance measurements.

- CE flicker mode

In this mode the LMG450 works as a full compliance flicker meter. All measurements are judged according to the standards. There is only a minimum of settings to prevent set-up errors.

- Harm100 mode

In this mode the LMG450 works as an harmonic analyser for 100 harmonic components. You get many values like phase angles and the power at each frequency.

- Transient mode

In this mode the LMG450 works as a transient recorder. You can define special events when the storage of values should be triggered.

The active mode depends on the setting in the *Measuring* menu. Some other menus also depend on this setting (see the respective description).

For each measuring mode you find a chapter in the manual. Inside this chapter the different menus for this operating mode are described.

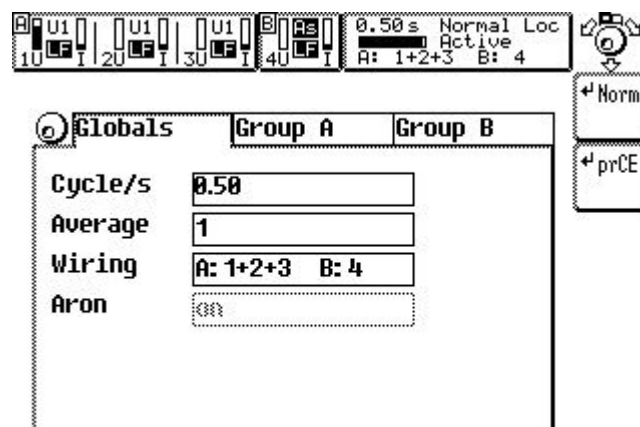

Figure 1: Measuring menu

2.3 General handling of the instrument

The main menus are reached by pressing the corresponding key of the keypad. In many menus you find softkeys which change their function depending on the menu. Above the softkey list you have symbols for the actual behaviour of the rotary knob:

blank The rotary knob is inactive (neither rotating nor pushing has any effects)



By rotating the knob, you can select different tabs. By pushing the knob, you get a new selection of softkeys in a lower menu layer.



By rotating the knob, you can select different actions (depends on the context of the menu). By pushing the knob, you go back one menu to the upper menu layer.



You are entering a text. The effect of the rotating depends on the softkey settings. By pushing the knob, the character at the cursor position of the selection list is copied to the input field. See also '4.5, Entering identifiers, characters and text'

All softkeys are of following types. They are identified by the small symbol in the upper left corner. The text in the softkeys depends on the context of the menu.



Execution softkey. The action described by the text is executed immediately without the possibility to cancel it.



Branch softkey. After pressing this softkey a new list of softkeys will appear. Now you can select one of this new softkeys or you can cancel the action by pressing *ESC*.



List softkey. After pressing this softkey you get a selection list. You can choose one element of the list (with the rotary knob) and then you can confirm your choice by pressing the rotary knob or *ENTER* or you can cancel the selection by pressing *ESC*.



Text edit softkey. After pressing this softkey you can enter identifiers (for example in the script editor or to output values via the analogue outputs). This kind of text input is described in '4.5, Entering identifiers, characters and text'



Rotary knob action softkey. This is a group of one or more softkeys. The softkey with the knob symbol is the actual active (in this case the knob would move the window). All inactive softkeys have no symbol in the upper left corner. If you in this example press on **Zoom** the symbol will change to this softkey.

If you have a small box like the '-x-' in the above Zoom button, the text in this box represents the actual setting. In the above example you would zoom the signal in X direction. If you press again this button, the content of the small box changes to '-y-' and you would zoom the signal in Y direction.



Count softkey. After pressing this softkey you can adjust the depending values with the opening up and down buttons in fixed steps.



Time softkey. After pressing this softkey you can adjust a time setting. The values for hours, minutes and seconds must be separated by a colon, pressing the button *Misc.* Then you can confirm your adjustments by pressing the rotary knob or *ENTER* or you can cancel the selection by pressing *ESC*.



Date softkey. After pressing this softkey you adjust a date. The values for day, month and year must be separated by a colon, pressing the button *Misc.* Then you can confirm your adjustments by pressing the rotary knob or *ENTER* or you can cancel the selection by pressing *ESC*.



Time duration softkey. After pressing this softkey you can adjust a time duration, in which e.g. an integration of values should be made. You can set up the duration in several data formats e.g. in seconds without a hyphen or by values for hours, minutes and seconds separated by a colon (pressing the button *Misc.*). Confirm your choice by pressing the rotary knob or *ENTER* or you can cancel the selection by pressing *ESC*.

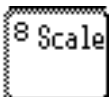

Digit softkey. After pressing this softkey you must enter numbers. Then you can confirm your choice by pressing the rotary knob or *ENTER* or you can cancel the selection by pressing *ESC*.

2.4 The group concept

The four power measuring channels allow a lot of measuring capabilities, but they require also a special handling. For this reason we have used so called ‘groups’. In one group you find one or more measuring channels which belong logically together. A group is a logical unit and there are several menus which display values out of one group or which set-up parameters for one group (e.g. ranges). The groups are defined by the selected wiring (see the chapters about the measuring menu).

You can have three principle measuring situations:

- You measure with all 4 channels (group A) at the same system (which means you have the same frequency at each input). Examples for such systems are 4 phase motors driven by

frequency converters or standard main supply with L1, L2, L3, N and PE (in this case you could for example measure I_N and U_{NPE} !)

In this situation there is no group B!

The standard wiring for this is '4+0 Channels'.

- You measure with 3 channels (group A) at one system and with the 4th channel (group B) at another system. Examples for such systems are standard 3 phase systems with one phase output, motor applications at frequency converters where the torque is measured with the 4th channel or car applications, where the 4th channel measures the DC power of the battery. The standard wiring for this is '3+1 Channels'.

If you have installed the option star to delta conversion, (L45-O6) you have three further possible wirings:

'3+1, $U * I^* \rightarrow U \Delta I \Delta$ '

'3+1, $U \Delta I^* \rightarrow U \Delta I \Delta$ '

'3+1, $U \Delta I^* \rightarrow U * I^*$ '

- You measure with 2 channels (group A) at one system and with the other two channels (group B) at the second system. Examples for this could be three phase converter from 50Hz to 60Hz.

Both groups are measured in 2 wattmeter method. There are two possible applications:

You measure a 3phase, 3wire system (aron circuit, **Aron** set to on)

You measure a 2phase, 3wire system. (**Aron** set to off).

The standard wiring for this is '2+2 Channels'. If you have installed the option star to delta conversion (L45-O6) you have two further possible wirings:

'2+2, $U \Delta I^* \rightarrow U \Delta I \Delta$ '

'2+2, $U \Delta I^* \rightarrow U * I^*$ '

If a group has more than one measuring channel, you can get additional information about the group:

- In many cases the instantaneous values of all used measuring channels are calculated together. By this you can see for example the not measured voltages and currents in wiring '2+2 Channels' (aron circuit).

This virtual channel can be used like a standard channel (you get all values, scope, harmonics, flicker, ...)

This kind of channels we call 'linked channels'

- The total values of a group are calculated (total active power, total power factor, total energy, ...).

This kind of channels we call 'sum channels'.

Following you find an overview over the different wirings, the groups, the measured values and where you can find the values in the display. The definition of the header can be found in chapter 5.4, 'Display of values'.

Wiring '4+0 Channels'

Display channel	Group	Meaning	Header
1	A	The values measured with the first measuring channel	Chn1 A:1
2	A	The values measured with the second measuring channel	Chn2 A:2
3	A	The values measured with the third measuring channel	Chn3 A:3
4	A	The values measured with the fourth measuring channel	Chn4 A:4
13	A	The total values (sum channel) of group A (display channel 1 to 4)	Sum(1-4) A:13

For typical measuring circuit see 3.3.1, 'Measuring circuit for typical line applications using the internal current path'.

Wiring '3+1 Channels'

Display channel	Group	Meaning	Header
1	A	The values measured with the first measuring channel	Chn1 A:1
2	A	The values measured with the second measuring channel	Chn2 A:2
3	A	The values measured with the third measuring channel	Chn3 A:3
4	B	The values measured with the fourth measuring channel	Chn4 B:4
13	A	The total values (sum channel) of group A (display channel 1 to 3)	Sum(1-3) A:13

For typical measuring circuit see 3.3.2, 'Measuring circuit for measuring efficiency of 3/1 phase systems'.

Wiring '2+2 Channels'

Display channel	Group	Meaning	Header with Aron set to off
1	A	The values measured with the first measuring channel	Chn1 A:1
2	A	The values measured with the second measuring channel	Chn2 A:2
3	B	The values measured with the third measuring channel	Chn3 B:3

Display channel	Group	Meaning	Header with Aron set to off
4	B	The values measured with the fourth measuring channel	Chn4 B:4
5	A	The calculated (not measured) current I_3 and voltage U_{12} of group A (linked channel)	Link12 (U3,I3) A:5
6	B	The calculated (not measured) current I_3 and voltage U_{12} of group B (linked channel)	Link34 (U3,I3) B:6
13	A	The total values (sum channel) of group A (display channel 1 to 2)	Sum(1-2) A:13
14	B	The total values (sum channel) of group B (display channel 3 to 4)	Sum(3-4) B:14

For typical measuring circuit see 3.3.5, 'Measuring circuit for measuring efficiency of 3/3phase systems' if you replace 'L2' by 'N'.

Wiring '2+2 Channels'

Display channel	Group	Meaning	Header with Aron set to on
1	A	The values measured with the first measuring channel	Chn1 (U12,I1) A:1
2	A	The values measured with the second measuring channel	Chn2 (U32,I3) A:2
3	B	The values measured with the third measuring channel	Chn3 (U12,I1) B:3
4	B	The values measured with the fourth measuring channel	Chn4 (U32,I3) B:4
5	A	The calculated (not measured) current I_2 and voltage U_{31} of group A (linked channel)	Link12 (U31,I2) A:5
6	B	The calculated (not measured) current I_2 and voltage U_{31} of group B (linked channel)	Link34 (U31,I2) B:6
13	A	The total values (sum channel) of group A (display channel 1 to 2)	Sum(1-2) A:13
14	B	The total values (sum channel) of group B (display channel 3 to 4)	Sum(3-4) B:14

For typical measuring circuit see 3.3.5, 'Measuring circuit for measuring efficiency of 3/3phase systems'.

For further information about this tables see also chapter 5.3, 'Definition of measuring values'.

So a general rule what you see is:

All measuring channels

All channels calculated from sample values (linked channels)

All channels calculating the total values of a group (sum channels)

2.5 Linked values, star to delta conversion (option L45-O6)

If you have installed the option star to delta conversion you can calculate values, which you can't measure directly (for example if you have a load in delta circuit, and want to know, how big is the power in each load, you could use the wiring '3+1, UΔI*->UΔIΔ'. Then you would measure the current in the three phases and the voltages between the phases. As linked values you get the voltage, current, power and all other values of each load, refer the following figure).

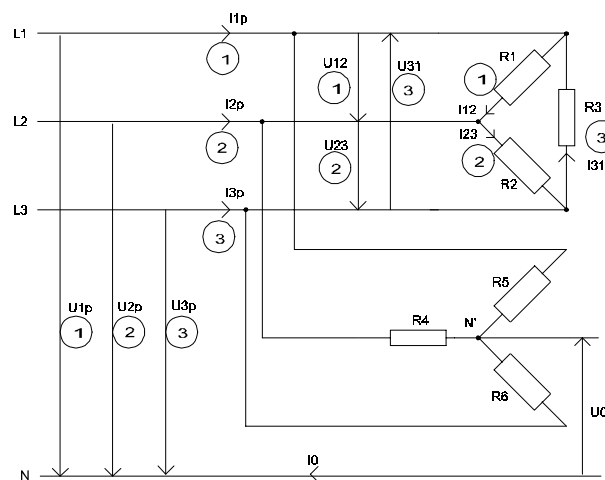

Figure 2: Allocations of the different linked values

Important note!

You can only perform a star to delta conversion, if this is physically possible. For the calculation we assume following conditions:

- $u1+u2+u3 = 0$
- $u12+u23+u31 = 0$
- $i1+i2+i3 = 0$
- $i12+i23+i31 = 0$

This assumption may not be met in following examples:

- You have a load in star circuit and there is a current flow out of the midpoint. So you can't transform this circuit to a equivalent delta circuit, because this would only have 3 wires instead of 4! This can be a typical problem when using frequency converters: Due to the high clock frequencies there might be a capacitive earth current which is the fourth „wire“.
- You have a circuit in a delta configuration. If there are additional sources in one or all of the three 'loads' (e.g. by induction), there can flow a current inside the delta circuit.

Following you find an overview over the different wirings, the groups, the measured values and where you can find the values in the display. After the grouping of the wiring you see how the signals are connected to instrument and what values are calculated.

Wiring '3+1, U*I*->UΔIΔ'

Display channel	Group	Meaning	Header
1	A	The values in star circuit measured with the first measuring channel (U_1, I_1)	Chn1 (U_1, I_1) A:1
2	A	The values in star circuit measured with the second measuring channel (U_2, I_2)	Chn2 (U_2, I_2) A:2
3	A	The values in star circuit measured with the third measuring channel (U_3, I_3)	Chn3 (U_3, I_3) A:3
4	B	The values measured with the fourth measuring channel	Chn4 B:4
5	A	The values in delta circuit, calculated from display channel 1 to 3 (U_{12}, I_{12})	Link123 (U_{12}, I_{12}) A:5
6	A	The values in delta circuit, calculated from display channel 1 to 3 (U_{23}, I_{23})	Link123 (U_{23}, I_{23}) A:6
7	A	The values in delta circuit, calculated from display channel 1 to 3 (U_{31}, I_{31})	Link123 (U_{31}, I_{31}) A:7
13	A	The total values (sum channel) of group A (display channel 5 to 7)	Sum(5-7) A:13

For typical measuring circuit see 3.3.2, 'Measuring circuit for measuring efficiency of 3/1phase systems'.

Wiring '3+1, UΔI*->UΔIΔ'

Display channel	Group	Meaning	Header
1	A	The values measured with the first measuring channel (U_{12}, I_1)	Chn1 (U_{12}, I_1) A:1
2	A	The values measured with the second measuring channel (U_{23}, I_2)	Chn2 (U_{23}, I_2) A:2
3	A	The values measured with the third measuring channel (U_{31}, I_3)	Chn3 (U_{31}, I_3) A:3
4	B	The values measured with the fourth measuring channel	Chn4 B:4
5	A	The values in delta circuit, calculated from display channel 1 to 3 (U_{12}, I_{12})	Link123 (U_{12}, I_{12}) A:5

Display channel	Group	Meaning	Header
6	A	The values in delta circuit, calculated from display channel 1 to 3 (U_{23}, I_{23})	Link123 (U23,I23) A:6
7	A	The values in delta circuit, calculated from display channel 1 to 3 (U_{31}, I_{31})	Link123 (U31,I31) A:7
13	A	The total values (sum channel) of group A (display channel 5 to 7)	Sum(5-7) A:13

For typical measuring circuit see 3.3.3, 'Measuring circuit (typical) for star to delta conversion (option L45-O6)'.

Wiring '3+1, U Δ *->U*I'

Display channel	Group	Meaning	Header
1	A	The values measured with the first measuring channel (U_{12}, I_1)	Chn1 (U12,I1) A:1
2	A	The values measured with the second measuring channel (U_{23}, I_2)	Chn2 (U23,I2) A:2
3	A	The values measured with the third measuring channel (U_{31}, I_3)	Chn3 (U31,I3) A:3
4	B	The values measured with the fourth measuring channel	Chn4 B:4
5	A	The values in star circuit, calculated from display channel 1 to 3 (U_1, I_1)	Link123 (U1,I1) A:5
6	A	The values in star circuit, calculated from display channel 1 to 3 (U_2, I_2)	Link123 (U2,I2) A:6
7	A	The values in star circuit, calculated from display channel 1 to 3 (U_3, I_3)	Link123 (U3,I3) A:7
13	A	The total values (sum channel) of group A (display channel 5 to 7)	Sum(5-7) A:13

For typical measuring circuit see 3.3.3, 'Measuring circuit (typical) for star to delta conversion (option L45-O6)'.

Wiring '2+2, U Δ *->U Δ I Δ '

Display channel	Group	Meaning	Header
1	A	The values measured with the first measuring channel (U_{12}, I_1)	Chn1 (U12,I1) A:1
2	A	The values measured with the second measuring channel (U_{32}, I_3)	Chn2 (U32,I3) A:2

Display channel	Group	Meaning	Header
3	B	The values measured with the third measuring channel (U_{12}' , I_1')	Chn3 (U12,I1) B:3
4	B	The values measured with the fourth measuring channel (U_{32}' , I_3')	Chn4 (U32,I3) B:4
5	A	The calculated (not measured) current I_2 and voltage U_{31} of group A (linked channel)	Link12 (U31,I2) A:5
6	B	The calculated (not measured) current I_2' and voltage U_{31}' of group B (linked channel)	Link34 (U31,I2) B:6
7	A	The values in delta circuit, calculated from display channel 1 to 2 (U_{12} , I_{12})	Link12 (U12,I12) A:7
8	A	The values in delta circuit, calculated from display channel 1 to 2 (U_{23} , I_{23})	Link12 (U23,I23) A:8
9	A	The values in delta circuit, calculated from display channel 1 to 2 (U_{31} , I_{31})	Link12 (U31,I31) A:9
10	B	The values in delta circuit, calculated from display channel 3 to 4 (U_{12}' , I_{12}')	Link34 (U12,I12) B:10
11	B	The values in delta circuit, calculated from display channel 3 to 4 (U_{23}' , I_{23}')	Link34 (U23,I23) B:11
12	B	The values in delta circuit, calculated from display channel 3 to 4 (U_{31}' , I_{31}')	Link34 (U31,I31) B:12
13	A	The total values (sum channel) of group A (display channel 7 to 9)	Sum(7-9) A:13
14	B	The total values (sum channel) of group B (display channel 10 to 12)	Sum(10-12) B:14

For typical measuring circuit see 3.3.5, 'Measuring circuit for measuring efficiency of 3/3phase systems'.

Wiring '2+2, UΔI*->U*I*'

Display channel	Group	Meaning	Header
1	A	The values measured with the first measuring channel (U_{12} , I_1)	Chn1 (U12,I1) A:1
2	A	The values measured with the second measuring channel (U_{32} , I_3)	Chn2 (U32,I3) A:2
3	B	The values measured with the third measuring channel (U_{12}' , I_1')	Chn3 (U12,I1) B:3
4	B	The values measured with the fourth measuring channel (U_{32}' , I_3')	Chn4 (U32,I3) B:4

Display channel	Group	Meaning	Header
5	A	The calculated (not measured) current I_2 and voltage U_{31} of group A (linked channel)	Link12 (U31,I2) A:5
6	B	The calculated (not measured) current I_2' and voltage U_{31}' of group B (linked channel)	Link34 (U31,I2) B:6
7	A	The values in star circuit, calculated from display channel 1 to 2 (U_1, I_1)	Link12 (U1,I1) A:7
8	A	The values in star circuit, calculated from display channel 1 to 2 (U_2, I_2)	Link12 (U2,I2) A:8
9	A	The values in star circuit, calculated from display channel 1 to 2 (U_3, I_3)	Link12 (U3,I3) A:9
10	B	The values in star circuit, calculated from display channel 3 to 4 (U_1', I_1')	Link34 (U1,I1) B:10
11	B	The values in star circuit, calculated from display channel 3 to 4 (U_2', I_2')	Link34 (U2,I2) B:11
12	B	The values in star circuit, calculated from display channel 3 to 4 (U_3', I_3')	Link34 (U3,I3) B:12
13	A	The total values (sum channel) of group A (display channel 7 to 9)	Sum(7-9) A:13
14	B	The total values (sum channel) of group B (display channel 10 to 12)	Sum(10-12) B:14

For typical measuring circuit see 3.3.5, 'Measuring circuit for measuring efficiency of 3/3phase systems'.

For further information about this tables see also chapter 5.3, 'Definition of measuring values'.

3 Installation

3.1 Unpacking and putting into operation

Having unpacked the equipment, it should be checked for signs of damage. Damage due to transportation should be reported to the equipment supplier at the earliest opportunity. If it is uncertain to use the damaged equipment safely, then the equipment should not be used.

The package should be stored for further transports (e.g. for the annual calibration according to ISO9000).

After delivery the following items should be present:

- 1 LMG450 4 channel measuring instrument
- 1 User manual
- 16 Safety laboratory leads, 2.5mm², 1m
- 1 Mains supply cable

Further accessories as listed in the delivery note.

The instrument should only be used in a clean and dry environment and must never be operated in excessively dusty or moist spaces. To ascertain sufficient air circulation the instrument should be operated in a horizontal position or tilted only to the degree possible by of the adjustable handle. The instrument should not operate in direct sunlight.

3.2 General set-up

In general the instrument stores the actual settings as well as the last used menu. Pressing the both lower softkeys when switching on the instrument until you hear a beep will reset all settings to the default parameters.

By this you can delete faulty scripts, which could block the instrument.

3.3 Connections of the LMG450

First of all please refer to chapter 1.1, 'Safety Instructions'.

To ensure correct power measurement polarity, connect the cabling to the test circuit so that the grey terminals (U and I) are used as a reference. In other words, the signal source should point towards the terminals U* and I*.

When working with DC voltages/currents, note that the terminals marked with the '*' are the positive connections.

The following diagrams are some examples for typical connections of the LMG450. But all other measuring circuits are also possible (e.g. circuits which measure the correct current instead of the correct voltage).

3.3.1 Measuring circuit for typical line applications using the internal current path

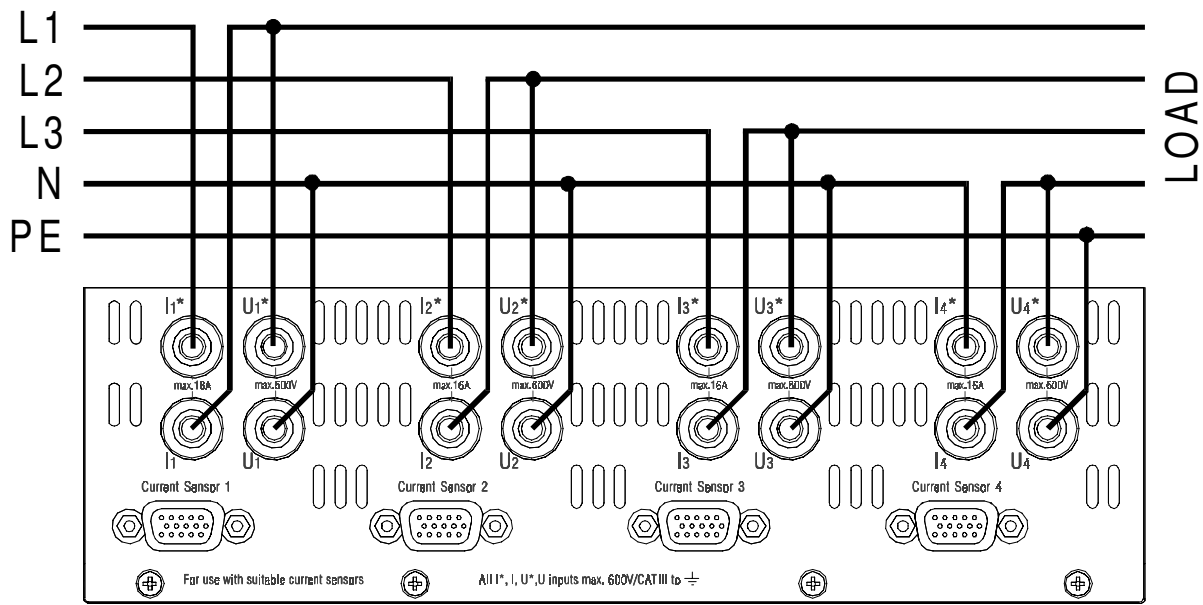

Figure 3: Measuring circuit 3 phase system with neutral

In this circuit we measure with the first three channels the voltage, current and power of the three phase system. With the fourth channel we measure additionally the current in the neutral wire and the voltage between neutral and earth. Of course you can use the same circuit without the fourth channel, if you are not interested in this values.

This circuit should be measured with wiring '3+1 Channels'.

Wiring '4+0 Channels' is also possible, but then the measured power of channel 4 would be added to the total power of the system (this could be correct, but depends very much on what you want to measure!).

3.3.2 Measuring circuit for measuring efficiency of 3/1 phase systems

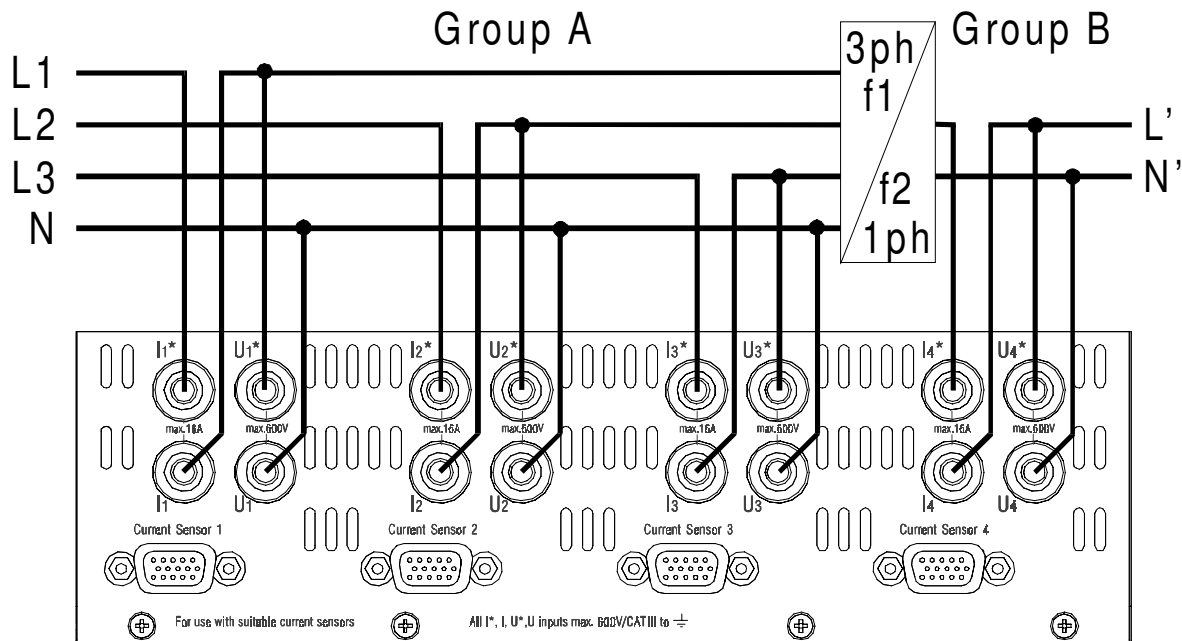

Figure 4: Measuring circuit for measuring efficiency (3/1 phase)

With group A you measure the three phase power, with group B the one phase power of the system. The frequencies of group A and B can be different.

You can use this circuit also in the other direction, when you have a one phase source and a 3 phase load (e.g. solar panel pushing energy to the mains).

This circuit should be measured with wiring '3+1 Channels'. If your 3phase load is an delta circuit and you have the option L45-O6 (star to delta conversion) implemented, you can also use the wiring '3+1, U*I*->U Δ I Δ ' to determine all the values of the delta circuit.

3.3.3 Measuring circuit (typical) for star to delta conversion (option L45-O6)

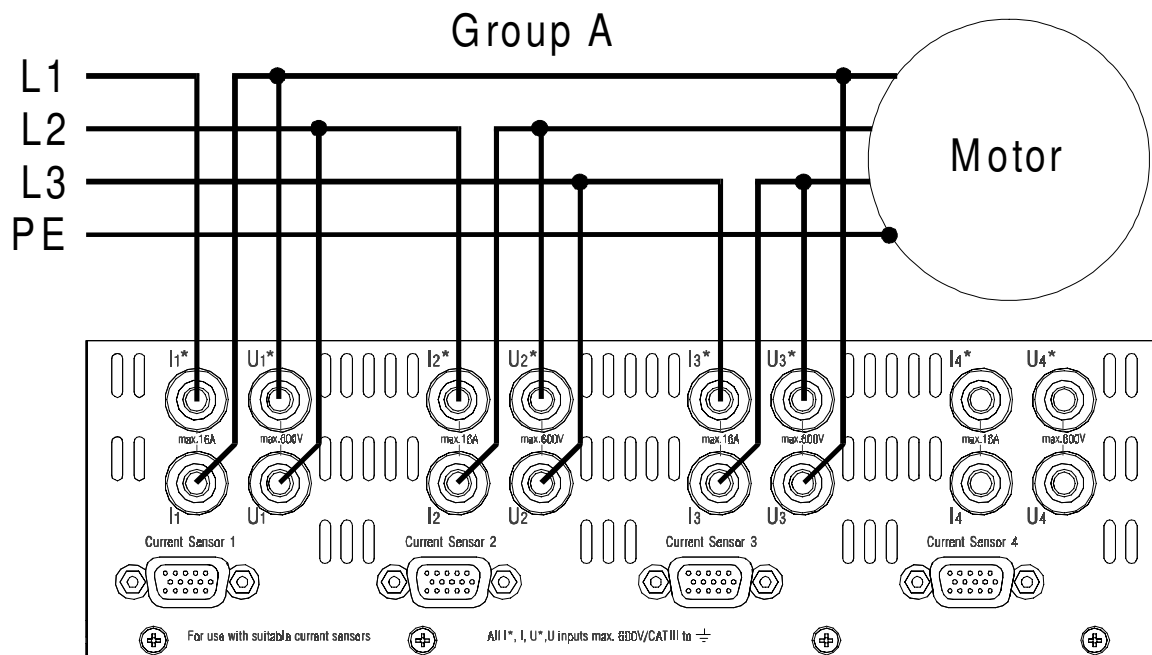

Figure 5: Star to delta conversion

With group A you measure the linked voltages and the currents in the phases. The LMG450 calculates with this both values a power for each channel, but this power will not be the power of the system, because the measured voltages (U_{12} , U_{23} and U_{31}) belong not to the currents (I_1 , I_2 and I_3). The power values are a mix from star and delta values.

But with the star to delta conversion, you can either transform the voltages to star voltages or you can transform the currents to delta currents. This will depend on your load. Now you have voltage and current in the same circuit and now you have also power values which exist in your circuit.

However the group B can be used independently like in the above examples.

This circuit should be measured with wiring '3+1, $U_{\Delta I^*} \rightarrow U_{\Delta I \Delta}$ ' or '3+1, $U_{\Delta I^*} \rightarrow U^* I^*$ '.

3.3.4 Aron wiring

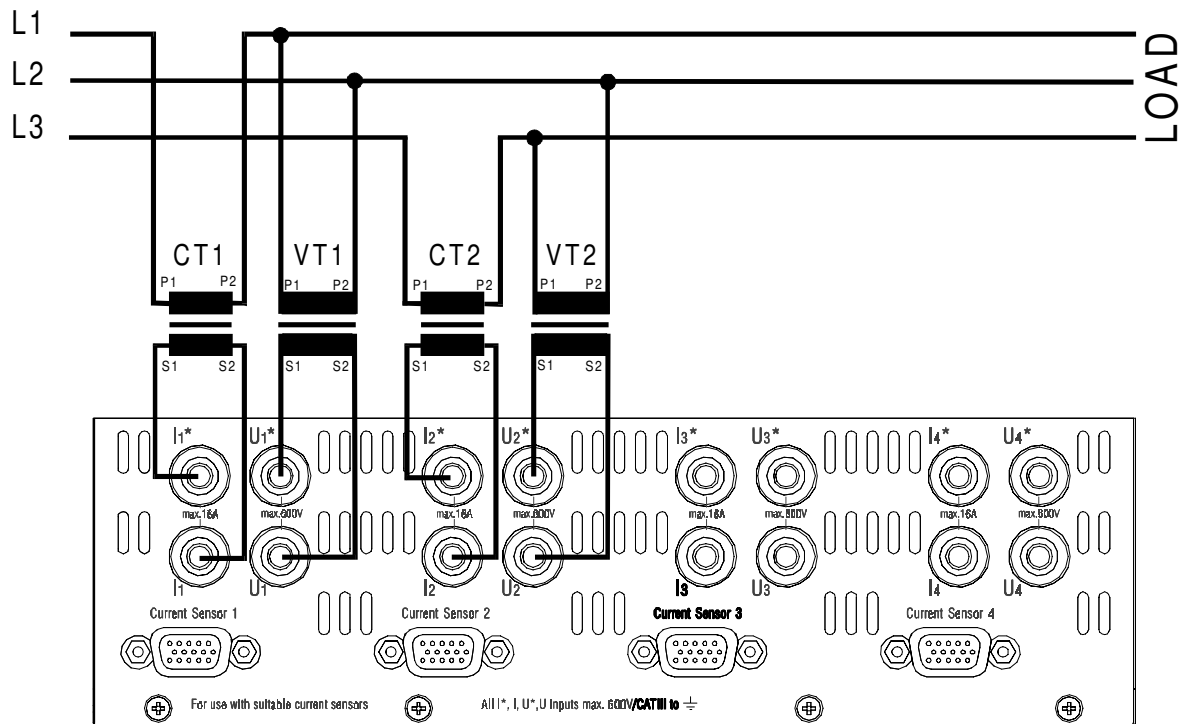

Figure 6: Measuring circuit with current and voltage transformers in Aron wiring

This wiring is for measuring the power of a three phase system without a neutral conductor. This circuit should be measured with wiring '2+2 Channels'. Here current and voltage are measured with transformers to enlarge the ranges, e. g. for measuring in middle or high voltage systems with also high currents. The both free channels could be used to measure another three phase system: refer „3.3.5 Measuring circuit for measuring efficiency of 3/3phase systems“.

When using voltage or current transformers please watch the applicable safety standards (e.g. earthing, isolation, ...)!

3.3.5 Measuring circuit for measuring efficiency of 3/3phase systems

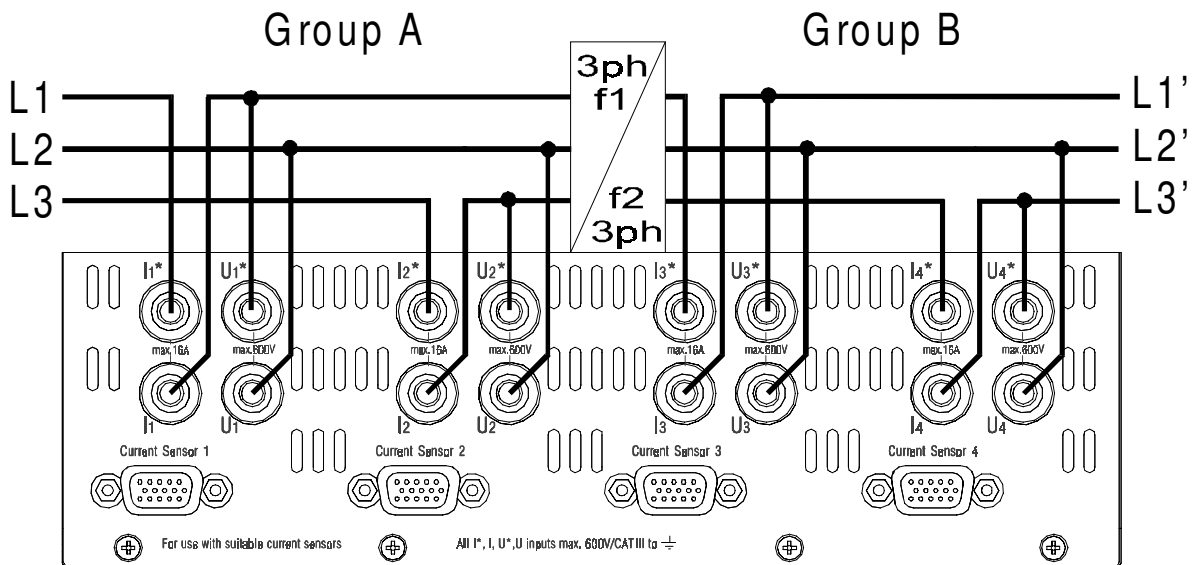

Figure 7: Measuring circuit for measuring efficiency (3/3phase)

With group A you measure the first three phase power, with group B the second one. The frequencies of group A and B can be different. This is a double aron circuit.

This circuit should be measured with wiring '2+2 Channels'. If you have the option L45-O6 (star to delta conversion) implemented, you can also use the wiring '2+2, UΔI*->UΔIΔ' (for a delta circuit load) or '2+2, UΔI*->U*I*' (for a star circuit load) to determine all the values of the load

3.3.6 Measuring circuit using an external current sensor

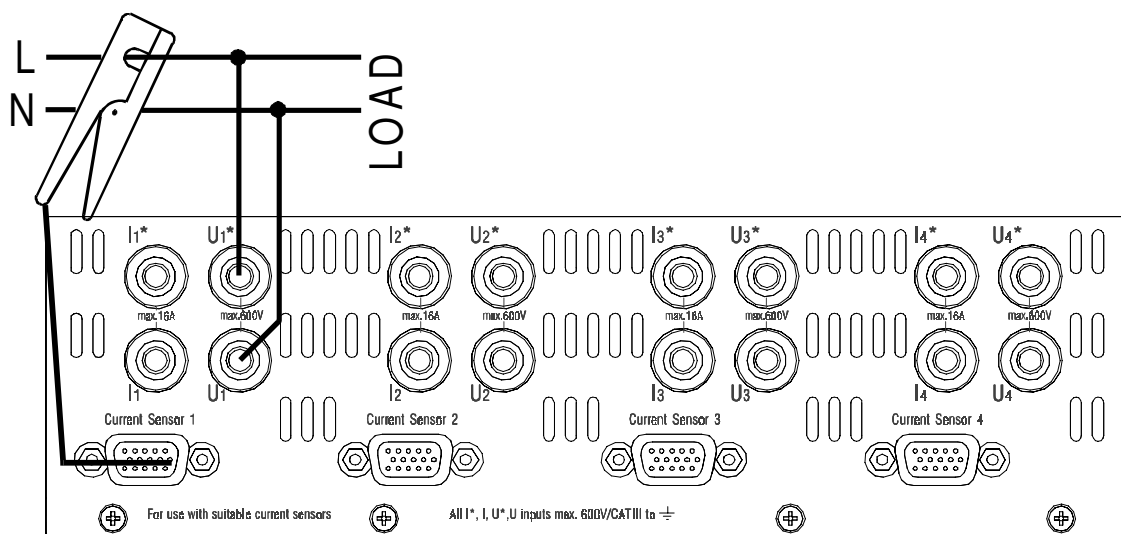

Figure 8: Measuring circuit with external current sensor

Here you see, how to install your current sensor.

For easy usage all ZES sensors have an EEPROM implemented in which we have stored the name, scaling, ranges, adjustment and delay time. The LMG450 recognises automatically, which ZES sensor is connected and sets up the range menu. Further on we correct some of the errors the sensor produces (transfer error, delay time). So you get the best measuring results with each sensor.

Most sensors are supplied by the instrument. But some have an additional 9 pin SUB-D connector for an external supply (for example PSU-S6). This has also to be connected.

In this monophas application you could use every wiring.

When having shielded wires were the current has to be measured, make sure that you do not measure the current in the shield!

3.3.7 Measurement of high currents

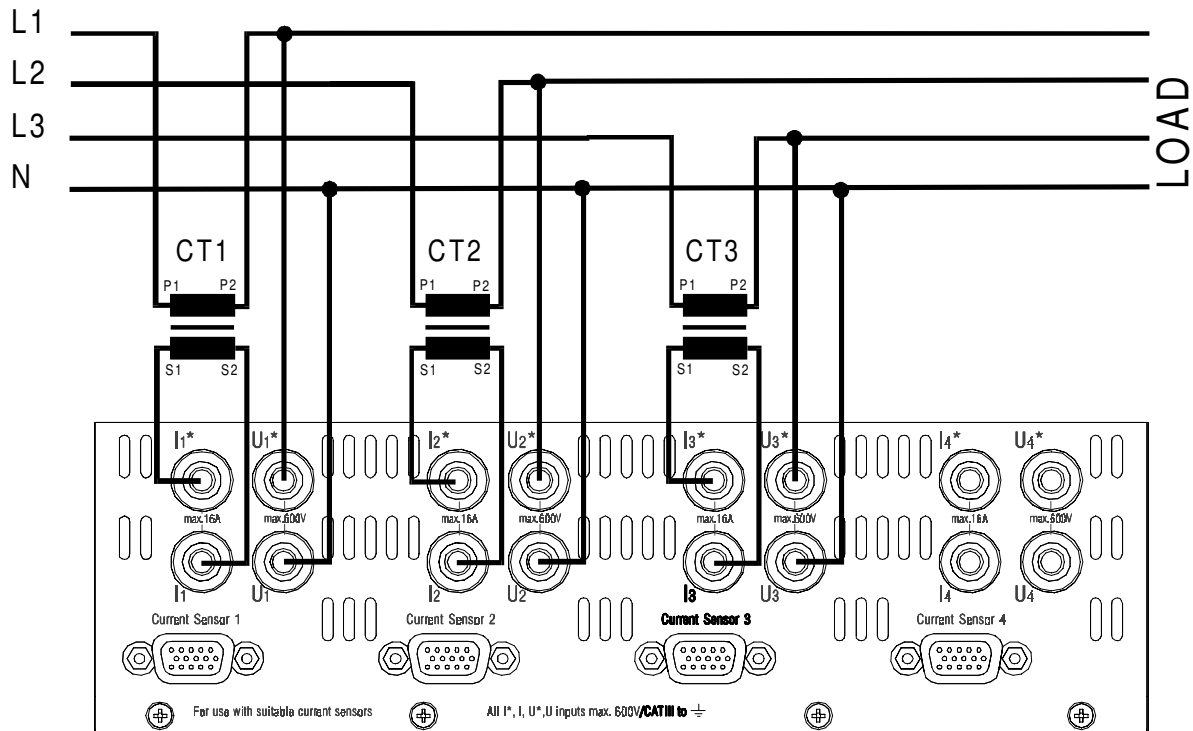

Figure 9: Measuring circuit for measuring high currents with transformers, voltage directly

In this figure you see how to measure a 3/4 phase system with high currents. The current path is connected via transformers to enlarge the ranges of the LMG450. For this measurement you should use the wiring '3+1 Channels'.

When using voltage or current transformers please watch the applicable safety standards (e.g. earthing, isolation, ...)!

3.3.8 Measurements at middle and high voltage systems

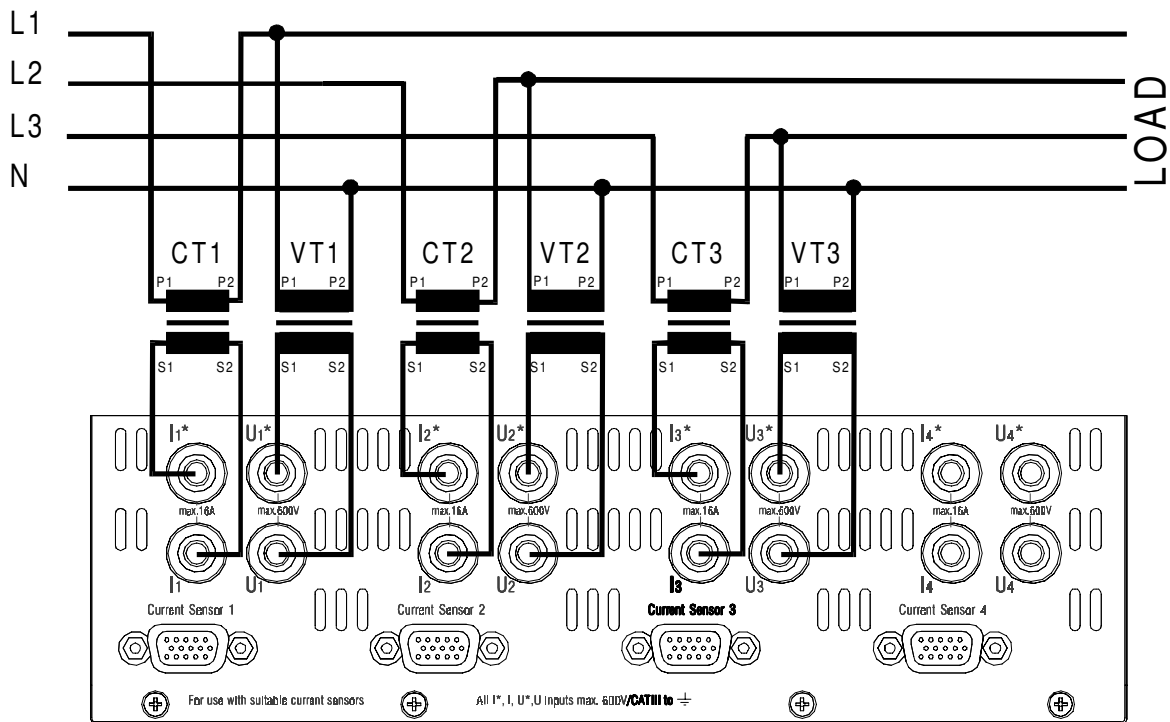
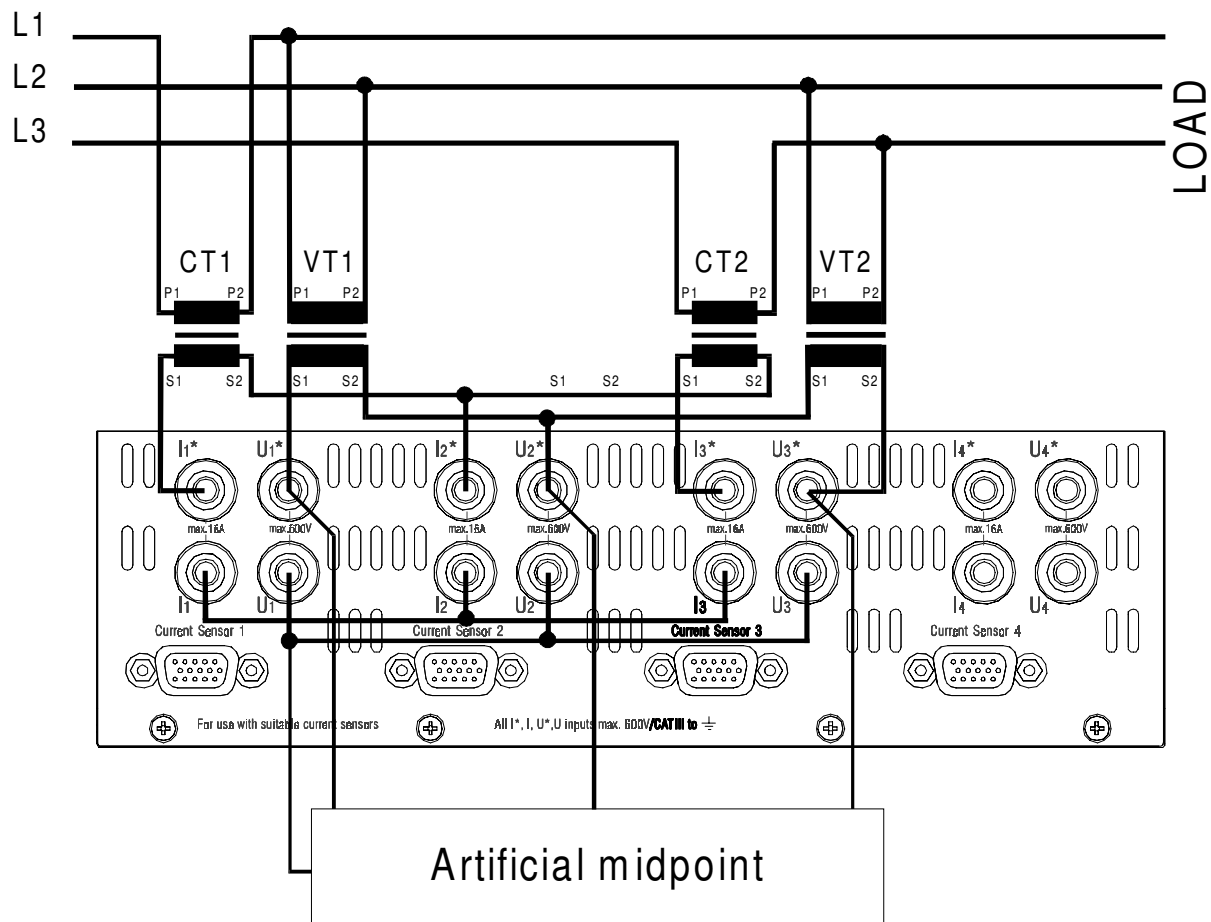

Figure 10: Measuring circuit for measuring in middle and high voltage systems

This is the measuring circuit for measuring in middle and high voltage systems. You can see that there is no PE conductor. For very high currents and voltages, there are transformers in each path implemented. The chosen wiring should be '3+1 Channels'.

When using voltage or current transformers please watch the applicable safety standards (e.g. earthing, isolation, ...)!

3.3.9 Measurements at middle and high voltage systems without N



**Figure 11: Measuring circuit for measuring in middle and high voltage systems without N
Using artificial midpoint**

This is the measuring circuit for measuring in middle and high voltage systems without the neutral N. You can see that there is no PE conductor. You just need each two transformers for voltages and currents. The chosen wiring should be '3+1 Channels'.

When using voltage or current transformers please watch the applicable safety standards (e.g. earthing, isolation, ...)!

Please note

The voltage resp. current transformers are connected each with by one common wire. Please make sure, that only this wire is connected to earth to prevent a short circuit of the current via the earthing.

3.3.10 Measurements at middle and high voltage systems without N

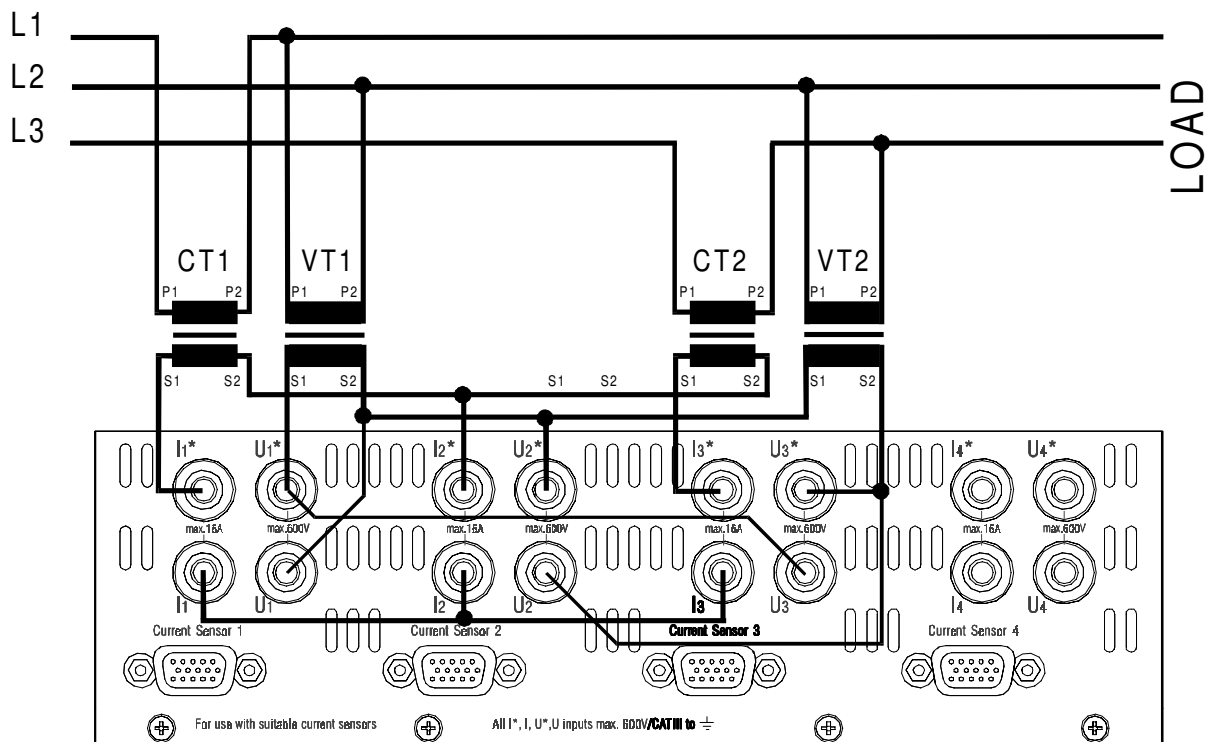

Figure 12: Measuring circuit for measuring in middle and high voltage systems without N Using star to delta conversion

This is the measuring circuit for measuring in middle and high voltage systems without the neutral N. You can see that there is no PE conductor. You just need each two transformers for voltages and currents. The chosen wiring should be '3+1, UΔI*→UΔIΔ' or '3+1, UΔI*→U*I*'.
 $U_{\Delta I^*} \rightarrow U_{\Delta I \Delta}$ or $U_{\Delta I^*} \rightarrow U * I^*$.

When using voltage or current transformers please watch the applicable safety standards (e.g. earthing, isolation, ...)!

Please note

The voltage resp. current transformers are connected each with by one common wire. Please make sure, that only this wire is connected to earth to prevent a short circuit of the current via the earthing.

4 Instrument controls

4.1 Front panel

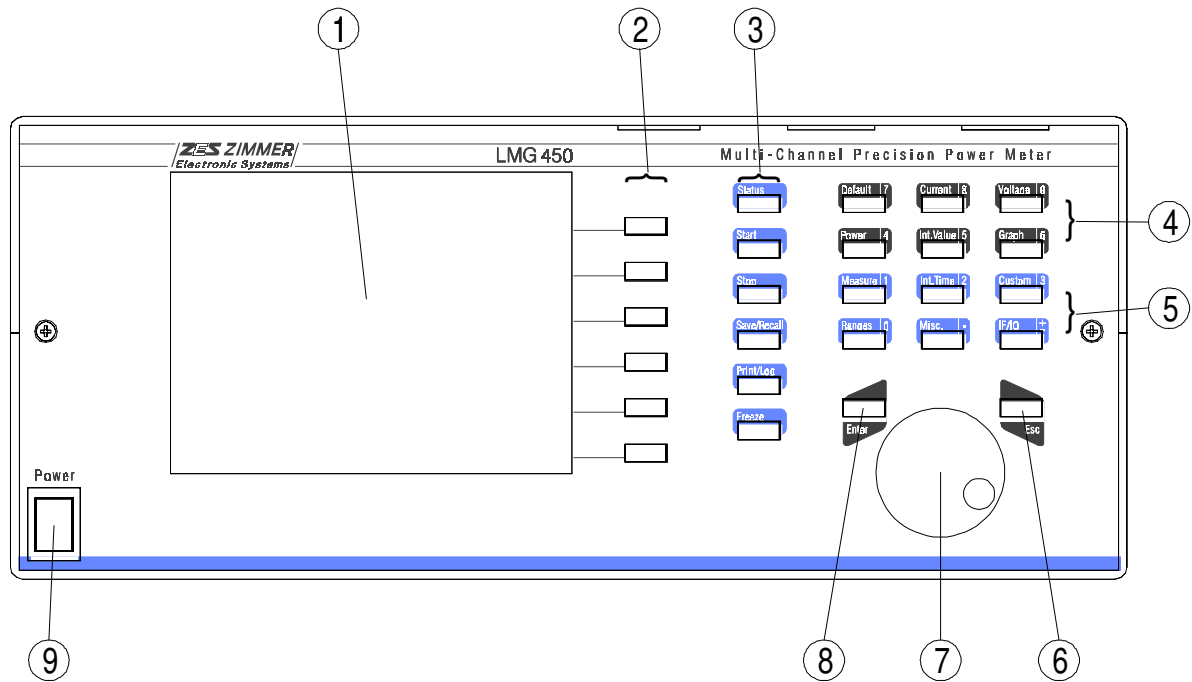

Figure 13: Front panel of the instrument

1. Graphical Display

2. Softkeys

Their function depends on the indicated function in the display.

3. Special function keys

Status: Here you get status information about the LMG450

Start: This key is used to start time dependent measurements

Stop: This key is used to stop time dependent measurements

Save/Recall: The actual menu is stored to the memory card

Print/Log: The actual menu is send to the printer output or logger

Freeze: Holds the measuring values of the last cycle in the display or enables the refresh of the display after each cycle

4. Dark menu selection keys

With this keys you can call different menus with the pure measuring values:

Default, Current, Voltage, Power, Int. Value and Graph.

A second function of this keys is to enter the digits from '4' to '9' when in a number entering mode.

5. Violet menu selection keys

With this keys you can call several menus for setting up the instrument:

Measure: The main measuring parameters

Int. Time: The parameters for time dependent measuring

Custom: The set-up of the custom defined menus

Ranges: The range selection of the measuring channels

Misc.: Setup of date, time and display brightness.

IF/IO: Setup of options

A second function of this keys is to enter the digits from '0' to '3' and '.' and '-' when in a number entering mode.

6. ESC key

This key is used cancel an entering mode and to quit an error message.

7. Rotary knob

This knob is used for several number settings, for selections in lists and for cursor moving.

A turn to the right increases the number. In many cases you can also push the knob to confirm a selection.

8. ENTER key

This key is used to finish an entering and to quit an error message

9. Mains switch

4.2 Rear panel

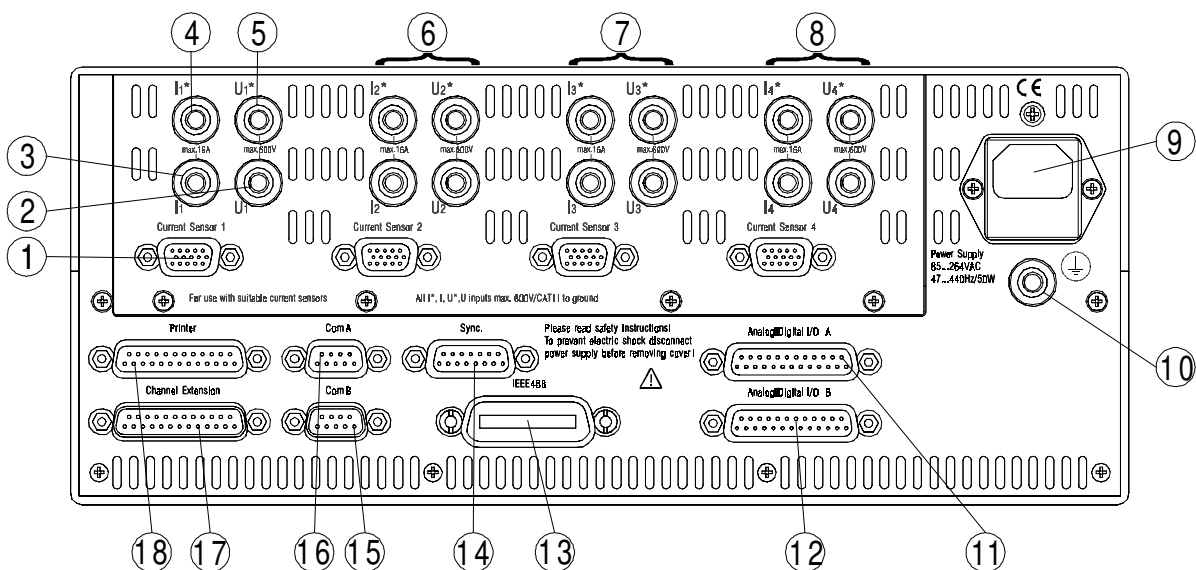

Figure 14: Rear panel of the instrument

First measuring channel:

1. External current sensor input
Input for voltages from external isolating transformers or sensors. 15-pin HD socket
2. U
Voltage input (low), 4mm black safety socket, surface mounted (grey and panel mounted with older instruments).
3. I
Current input (low), 4mm grey safety socket
4.
Current input (high), 4mm violet safety socket
5.
Voltage input (low), 4mm yellow safety socket, surface mounted (violet and panel mounted with older instruments).
6. Second measuring channel with same sockets like first channel
7. Third measuring channel with same sockets like first channel
8. Fourth measuring channel with same sockets like first channel
9. Mains
Fused chassis plug with holder for fuses.
10. PE
Connector for additional earthing, 4mm green/yellow safety socket
11. First analogue I/O card
Additional analogue and digital inputs and outputs for auxiliary signals.
12. Second analogue I/O card
Additional analogue and digital inputs and outputs for auxiliary signals.
13. IEEE488
Parallel interface, 24-pin micro-ribbon socket
14. Sync.
Socket for external synchronisation and measuring time control of the LMG450.
15-pin SUB-D socket
15. ComB: Serial RS232 interface
This is a serial interface which can be used for remote control, but usually it is used for special devices, like the LAN adaptor L45-Z318
9-pin SUB-D jack

16.ComA: Serial RS232 interface

This is the standard serial interface for remote control of the LMG450.

This interface is also used for software updates and service purposes.

9-pin SUB-D socket

17.Channel extension

Here you can later on connect additional measuring channels.

18.Printer

Centronics compatible interface or printer connection

25-pin SUB-D socket

4.3 Display

The display is divided into 3 sections:

- The softkeys at the right border change their meaning depending on the actual menu. A softkey with a black background is an active softkey. A dotted softkey can not be used.
- The elements of the status line at the top of the display are described in '4.3.1 Status line'. In this line you can see the most important status information of the instrument. This line is always visible.
- In the main display the different menus are displayed. This can be measuring values, set up menus or graphs.
At the bottom of this region a possible error message is displayed. This error messages have to be quit by pressing *Enter* or *Esc*.

4.3.1 Status line

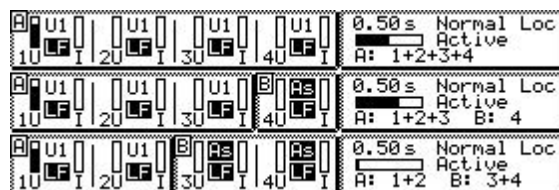

Figure 15: Status lines with 3 different wirings

The status line has the following sub sections (from left to right):

- The voltage and current signal level indicators. Here you can see how much of the actual voltage/current range has been used. This display is important for the selection of the measuring range. Between the two bars you can find two information: The upper one is the synchronisation source of the channel. Here you can find:
Un for the voltage channel n
In for the current channel n
XT for extended Trigger

Li for line synchronisation

Ex for external synchronisation

As (inverse) for asynchronous (no synchronisation)

The lower information can be:

‘LF’ (inverse displayed) indicating that the signal of the channel is low pass filtered.

The implemented ‘A’ and ‘B’ indicator show you, to which group the channels belong to.

- The time base indicator shows the actual chosen cycle time. The bar below this number shows how much of the cycle time is over.
- The mode indicator. In this line you see the chosen measuring mode. Possible values are ‘Normal’, ‘prCE’, ‘CE-Flk’, ‘HRM100’ and ‘Trans’.
In the line below ‘Active’ indicates, that the display is updated with measuring values. ‘Freeze’ indicated a frozen display. The current displayed values don’t change until ‘Active’ is chosen again (key *Freeze*).
- The remote indicator. ‘Rem’ indicates that the instrument is remote controlled by a PC. Some setting can now only be done by the PC but not at the front panel. ‘Loc’ indicates, that the instrument works as a stand alone instrument.
- In the last line you see the current chosen wiring.

4.4 General menus

If you are in a sub menu of a menu, you can reach the main menu by pressing the correct softkey, until you are in the main menu or you can press the menu button (e.g. *IF/IO*) again.

Here you find the description of menus which are equal for all measuring modes.

4.4.1 Misc.

Globals tab

Here you can do 4 settings:

Date Here you can enter the actual date. This date is used inside the instrument.

Time Here you can enter the actual time. This time is used inside the instrument. Instead of the ‘:’ you have to enter a ‘.’.

Contr Here you can setup the contrast of the display.

Color Here you can set-up the colours of the display.

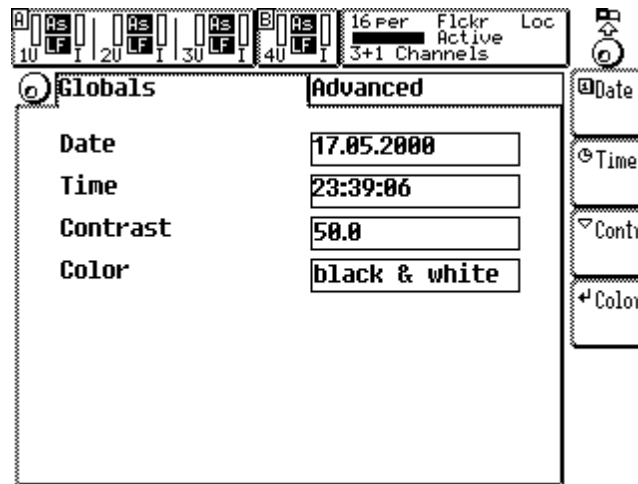

Figure 16: Misc. menu

Advanced tab

Here you can set-up some advanced, special things which should not be used under usual conditions. Just users which are sure to know what they do should change values in this menu. With wrong settings measuring results might be wrong! Following things can be set-up:

Zero The zero point rejection (see 13.2, 'Display of values') can be switched off. It will be activated again each time you restart the instrument.

Phan. Vals. The rejection of phantom values can be deactivated. Phantom values appear for example at wiring '3+1, UΔI*->UΔIΔ', because the measured star current has physically nothing to do with the measured triangle voltage. But the power measuring channel sees both signals at the same time and calculates a power for them, the phantom power.

Z-Adj. allows you to adjust the zero point of the instrument. You can only adjust the actual selected voltage and current jacks. You can reset the instrument to the factory settings of calibration by holding the lower two softkeys pressed while switching on the instrument (for about 10s, until the instrument beeps).

Be careful with this function because you can also deadjust the instrument!!!

For the exact adjustment steps please refer to 12.3.2 'Adjustment

The adjustment has to be done at $(23 \pm 1)^\circ\text{C}$.

ZES ZIMMER offers in principle a way to adjust the instruments outside our factory, if some technical preconditions are fulfilled. For further information, please contact sales@zes.com

Zero adjustment of the instrument'.

4.4.2 IF/IO

In this menu you can set-up all features which are available as instrument options. Further on you see the actual software version and the installed options. With **List** you can choose a short list or detail list. In the last one you can scroll with the rotary knob.

4.4.2.1 Interfaces for remote control

With exception of the IEEE interface all interfaces could also be used for data logging (see 11, 'Logging of values to drives, printer and interfaces'). To remote control the LMG you first have to set-up the wished interface for this job.

Press several times *IF/IO* to reach the IF/IO menu. By pressing **IF** you can set-up the remote device. You have several available 'profiles' from which you can select one (with **Dev.**). These profiles are predefined but they can be modified when necessary (with **Set**).

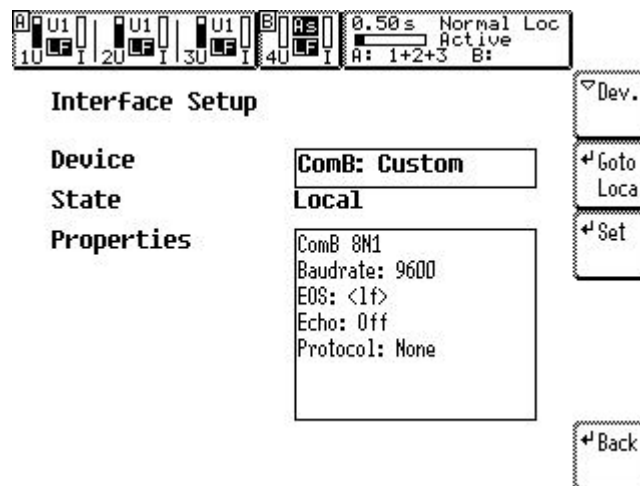

Figure 17: Interface Setup

If you modify the remote control profile for ComA the data logging profile for ComA is not changed!

If you want to reserve an interface for logging, it can happen that this interface is already used for logging. In this case you are asked, if you want to reassign it for logging. Press *Enter* to do this or *Esc* to cancel.

4.4.2.1.1 Remote control profiles

The actual setting of a profile are displayed under properties. You can change them by pressing **Set**.

Following profiles are available. You get just these displayed which are physically present:

ComA: Terminal

Choose this profile if you are not familiar with the remote possibilities of the LMG and you want to try to enter some commands manually via a terminal program. You can just change the baud rate. The other parameters are set up to values (EOS=Terminal, Echo=off, Protocol=None) so that you can work with most terminal programs directly. The default value for the baud rate is 9600 baud.

ComA: Script

Instead of entering a script via the rotary knob you can also transfer it via the serial interface. If you want to do this, you can get a freeware program from ZES. This profile is predefined to communicate with this program. You just have to set-up the profile, connect LMG and PC with a 1:1 cable and start the software.

With this software you can create, read out, modify, write and save a script.

ComA: OEM Appl

This should be chosen for external software like SYS61K, TERM-L5, LMG-Control, CE-Test61k or other software from ZES (if no other specification in the software exists). Most parameters are fixed (EOS=<lf>, Echo=off, Protocol=RTS/CTS) and you can just modify the baudrate. Default value is 38400 baud.

ComA: Custom

If you want to implement the LMG into your own system, you can set-up in this profile all parameters:

- Baudrate** The serial interface supports baud rates from 1200 (maximum about 100 characters per second) up to 115200 baud (10000 characters per second). Usually you use the biggest value. Some old PC support just up to 38400 baud.
- EOS** End-Of-String character(s). This are the characters which mark the end of a command or answer. Possible values are '<lf>', '<cr>', '<cr><lf>' and 'Terminal'. In 'Terminal' mode each '<cr>' of the computer is answered by a '<cr><lf>' of the LMG450. By this you get a nice display if you use an terminal program (if you have also activated the echo).
- Echo** If this is set on, each character you send to the LMG is returned to the sender. By this you can check, if the cable is working and in a terminal program you see, what you have typed.
- Protocol** The LMG supports 'None' protocol and 'RTS/CTS'. The last one is a hardware handshake. It should be used, if the computer can't read all data in real time and it gets very many data.

ComB: Custom

Same like ComA. Please note that you have to use a null modem cable.

GPIB

If you want to use this interface you need a GPIB controller in your PC. You have just to set-up the address of the LMG (in the range from 1 to 30).

4.4.2.1.2 remote <-> local

If you send any characters to the LMG it changes to the remote state (you see a 'REM' in the status line). Then it is impossible to change any parameters like cycle time, because this might conflict with an actual remote command.

To leave this remote state you can send an 'go-to-local' command via interface or you can press the **Goto Local** softkey.

If you send further characters to the instrument it changes back to the remote state.

4.4.2.2 Processing signal interface (option L45-O3)

With **IO** you reach the set-up menus for the processing signal interface. With the rotary knob you can select four tabs ('A_In', 'A_Out', 'D_In' and 'D_Out'). By pressing the rotary knob you can set-up each tab. **Back** returns to the *IF/IO* menu.

In the LMG450 you can install one or two processing signal interface cards. So the number of channels which are displayed in each menu depends on the number of installed cards.

4.4.2.2.1 Analogue Input tab

If you are in the setting mode of this menu, you can with the rotary knob select a channel.

Zero Here you set-up, which value will be displayed with 0V input.

FS Here you set-up, which value will be displayed with 10V input.

Example: You select **Zero** '30' and **FS** '120'. Now you get with 0V input a display of 30, with 10V input a display of 120 and with 5V input a display of 75. The output is updated every measuring cycle.

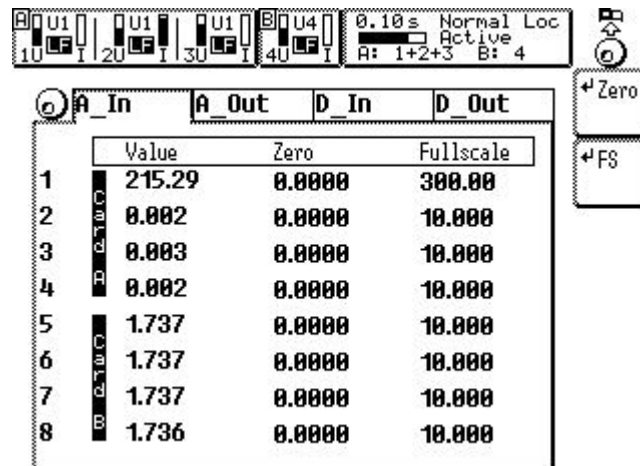

Figure 18: Analogue inputs

Pressing the rotary knob returns you to the tab selection.

4.4.2.2.2 Analogue Output tab

If you are in the setting mode of this menu, you can with the rotary knob select a channel.

Value This allows you to set-up the value which should be output. See chapter 4.5, 'Entering identifiers' for details.

Zero Here you set-up, which value of **Value** will result an output of 0V.

FS Here you set-up, which value of **Value** will result an output of 10V.

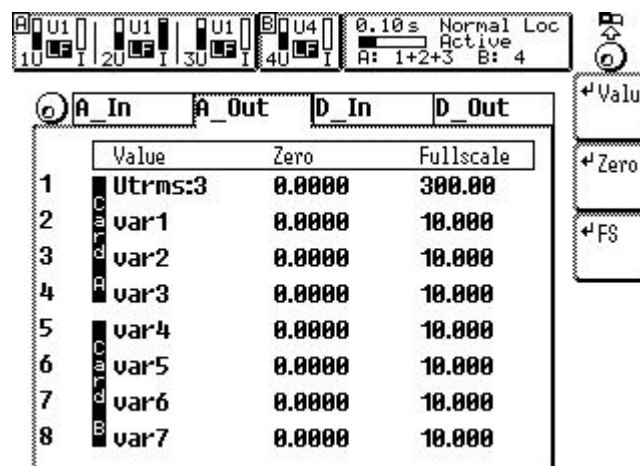

Figure 19: Analogue outputs

Example: You select **Value** 'Utrms', **Zero** '200' and **FS** '250'. Now you get with Utrms=200V an output of 0V, with Utrms=250V an output of 10V and with Utrms=230V an output of 6V. The output is updated every measuring cycle, because the values are calculated every measuring cycle.

Pressing the rotary knob returns you to the tab selection.

4.4.2.2.3 Digital Inputs tab

In this menu you get the actual state of the digital inputs. The inputs 1 to 4 of each card are only used for state indication. The inputs 5 and 6 can be used as state indicators or for frequency and direction input (determined by the phase shift between input 5 and 6). In the last case the input 5 is used to measure the frequency. This is multiplied with the 'Scale' value and displayed under 'Frequency'. A negative frequency value indicates a reverse rotation direction. To change the scaling press the rotary knob and **Scl.A** (or **Scl.B** for the card B).

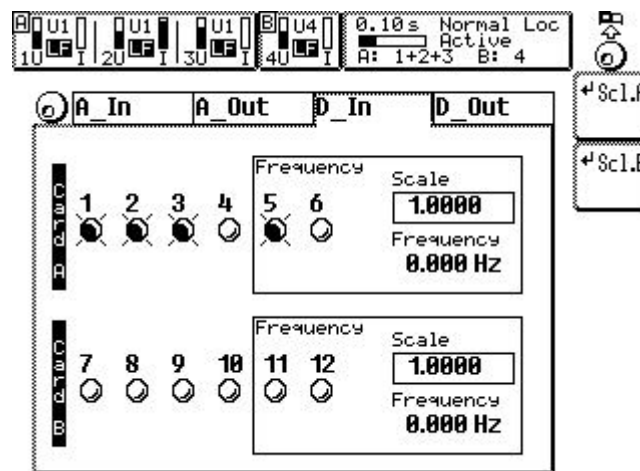

Figure 20: Digital inputs

Pressing the rotary knob returns you to the tab selection.

4.4.2.2.4 Digital Outputs tab

If you are in the setting mode of this menu, you can with the rotary knob select a channel.

Value This allows you to set-up the value which should be output. See chapter 4.5, 'Entering identifiers' for details.

Cond Here you set-up, under which condition the output is in the 'alarm state' (= high impedance of output, symbolised lamp is on!):

on: The output has always alarm state.

off: The output has never alarm state.

>=: The output has alarm state if the **Value** is bigger or equal to the **Limit**.

<: The output has alarm state if the **Value** is smaller than the **Limit**.

Limit Here you set-up, which limit is compared to the **Value**.

Example: You select 'Utrms:1 < 200V'. Now you get an alarm for every voltage smaller than 200V. The output becomes a high impedance state because a 'fail save' function is assumed.

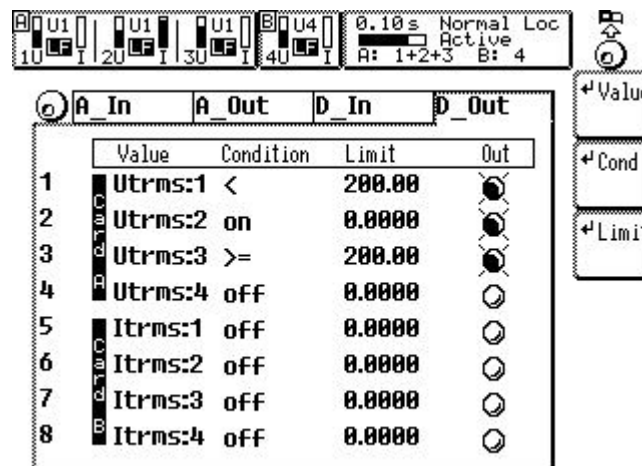

Figure 21: Limit menu

Pressing the rotary knob returns you to the tab selection.

Fail Save Principle

The fail save principle should offer you highest safety in critical applications. The principle is, that a high impedance state is the alarm (active) state. By this also broken or not connected wires as well as not switched on instruments are recognized as fail. Only the low impedance state is recognized as no alarm (deactive).

4.4.2.3 Options key

If you press on the softkey with the key symbol you get an actual software key which represents all installed options in your instrument. Some options of the instrument are software options which can be released by another key. If you for example want to install the 100 Harmonics you send us or your local sales company an order about this option together with your Current Option Key and with your serial number (SN).

Then you get back a second key which you can enter after pressing the key symbol. If the second key is correct, the option is installed.

Note

If you can access the instrument via an interface, you can use LMG-CONTROL to read out and update the key. This is much easier than working with the front panel.

4.4.3 Custom menu

In the standard menus *Voltage, Current, ...* (see chapters below) we have defined some values to be displayed which should fit to most customers. For some special applications you can define in the *Custom* menu your own values and graphics which should be displayed. Further on you can define your own values by using the integrated script editor (see 4.4.4, 'Script/Formula editor').

When entering you get at least two tabs. To change between the tabs, you have to use the rotary knob. To get the softkeys inside a tab you have to press the rotary knob.

4.4.3.1 New menu tab

Here you first have to define the name of a new (user defined) tab with **Name**. Then you have to define the mask for the menu with **Form**. Depending on this mask you can define up to 50 values for a menu. If everything is finished you can create the new menu by pressing **Make new**. The new menu appears as a new tab which can be edit (see 4.4.3.3, 'User defined tab').

You can define up to 8 menus.

With **Load** you can recall a previously saved menu from memory card or floppy if installed. You have to select a filename from the list.

4.4.3.2 Vars tab

In the Vars tab you see all variables. By default they are named 'var0' to 'var11'. With **Reset** you can set them all to '0.0'. With **Edit** you enter the script editor. Here you can define new variables, formulas as well as small scripts to control your measuring. For a detailed description see 4.4.4, 'Script/Formula editor'.

4.4.3.3 User defined tab

Here you do the definitions, which values appear at which place. With the rotary knob you choose the position and press **Edit Item**. In the dialog you choose with **Typ** the kind of data to display:

- | | |
|------------|---|
| empty | The item will be displayed blank. Choosing this is the same like pressing the Del Item softkey. |
| Value | When choosing this have to choose with Prop a measuring value which should be displayed as value with unit, but without identifier. How to enter the Prop value see 4.5, 'Entering identifiers, characters and text'. |
| Name+Value | When choosing this have to choose with Prop a measuring value which should be displayed as value with unit and with leading identifier. How to enter the Prop value see 4.5, 'Entering identifiers, characters and text'. |

- String** When choosing this have to choose with **Prop** a text which should be displayed. How to enter the **Prop** value see 4.5, 'Entering identifiers, characters and text'.
- Graph** Here you get a list of all possible graphs. In principle you can display copies of graphs which you have already set-up in the *Graph* menu. 'Scp.A:1' selects the first waveform of the group A scope, 'Scp.B:3' the third waveform of group B scope. The 'Plot:x' is for selecting one of the four plot functions.
- To modify the graphical display you have to change to the *Graph* menu.

With **Font** you can choose another than the predefined font for the display.

With **Copy menu** you create a copy of the complete tab which can then be modified. With **Del menu** you can remove the complete tab. In a pop up menu you have to confirm this a second time.

To give a menu another name, please use **Edit Name**.

With **Save** you can store the menu to a memory card or floppy if installed. You have to select a filename from the list or enter a new one with **File name**.

4.4.4 Script/Formula editor

You reach the script/formula editor by pressing **Edit** in 'vars' tab in *Custom* menu.

With **Edit** you start entering the script. This is done like written in 4.5, 'Entering identifiers, characters and text'.

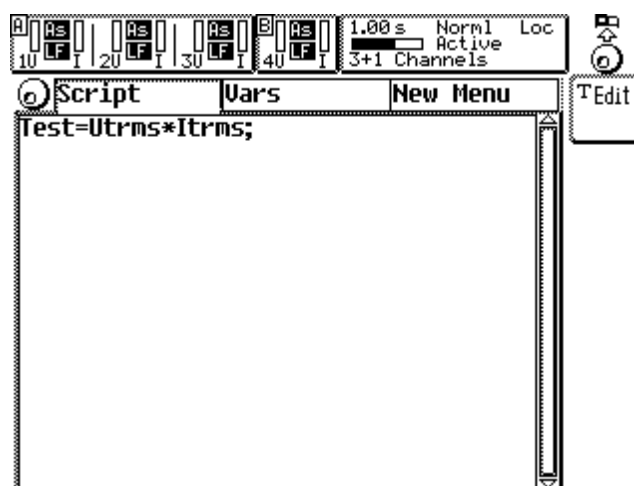

Figure 22: Script editor

With **Save** you can store the script to a memory card or floppy if installed. You have to select a filename from the list or enter a new one with **File name**.

With **Load** you can recall a previously saved script.

4.4.4.1 General

The script editor is similar like a simple programming language. The code is entered line by line. It is allowed to have several instructions in one line. Each instruction has to end with a ‘;’. Therefore an instruction can be written in more than one line. It is also allowed to have white spaces in the instruction as long as the keywords and identifiers are not divided by them. At the end of a line an automatic carriage return and linefeed are performed. A ‘#’ indicates the begin of a comment. The comment lasts, until a return is detected (can be entered with **new line**). An automatic inserted newline will NOT end the comment!

The instruction

```
v0=Utrms*Itrms;  
is identical to
```

```
v0 = Utrms* Itrms ;  
or
```

```
v0 =  
Utrms * Itrms;
```

<- deletes the character left of the cursor. If the cursor is at the first position of a line, it jumps to the last position of the previous line.

You leave the script editor by pressing **End**. The program is now checked for correct syntax. Above the editor window you see then how many percent of the available memory space have been used.

The script (which includes the formulas) is executed when all values of a cycle have been calculated.

With **Reset** all variables are preset to 0.0 but the script is still valid. This is important if you use recursive formulas or conditions.

4.4.4.2 Grammar

4.4.4.2.1 Instructions

Instructions control the program flow while execution. If there are no conditioned instructions, the flow is in the same order like the listing. The results of an instruction can be used afterwards.

An instruction consists of one or more expressions. Each instruction (except `if`, `else` and `fi`) has to be finished with `;`. An instruction can be longer than one line. The result must not be assigned to a variable.

4.4.4.2.2 Condition instruction

Condition instructions choose between two alternative program flows. This is done by the expression following immediately to the word `if`.

```
if(expression) Instructions; fi
or
if(expression) Instructions; else Instructions; fi
```

The brackets for the expression are necessary. Then there could be one or more semicolon separated instructions which are executed if the expression was true. The end of the conditional execution is marked with `fi`, which is also necessary. The `else` part is optional.

Condition instructions can be nested, for example to realise a logical AND:

```
if(expression1)
  if(expression2)
    Instruction 1;
    :
    Instruction n;
  fi
fi
```

Example

```
if (Utrms>227.5)
  dout_off(1);
  dout_off(2);
else
  dout_on(4);
fi
```

If the voltage is bigger than 227.5V the digital outputs 1 and 2 are set to off. In the other case the output 4 is set to on.

4.4.4.2.3 Expressions

An expression is a sequence of operators, operands and functions. Expressions are in general recursive, which means they can be nested. But there is a practical limit in CPU power and memory which can cause the message „out of memory“.

The order of evaluation of an expression depends on the priority of operands and on the brackets (see below).

4.4.4.2.4 Constants

Constants are always floating point. The valid range is $\pm 3.4E-34$ to $\pm 3.4E+34$. The number can be entered in usual or scientific notation. The decimal dot is only necessary for floating point numbers.

4.4.4.2.5 Variables

There is a distinction between read only variables and read write variables. The first ones are all measuring values of LMG450 but also values like cycle time and measuring ranges. This variables can be used for calculation like constants. The second one are the user defined variables.

So following is o.k.

```
v0=Utrms;
but
```

```
Utrms=0;
is not allowed.
```

A unit can be assigned to the variable. To assign the unit 'cm' to the variable 'a' write:

```
a.cm=...
```

The result of expressions can only be stored in the user defined variables with the default identifiers 'var0' to 'var11'. This identifiers are valid until they are redefined in a script. The redefinition is simply be done by using a not existing identifier. This identifier replaces the first variable which was not changed until now. The maximum length of the new identifier is 10 characters. In 'Example 2' the identifier **uhigh** replaces the identifier **var0** and **ulow** replaces **var1**. As you can see the identifiers are replaced in the order of the occurrence. If you press **End**, all occurrences of **var0** are replaced with **uhigh** and so on. So you get in the user defined menu or the plot menu the new identifiers.

The read-only variables are identical to the identifiers in the menus (see 4.5, 'Entering identifiers').

4.4.4.2.5.1 Local variables

A third kind of variables are local variables. They are also user defined, but are not displayed in the custom menu. A local variable starts always with a '\$' character:

```
$test=Utrms*19.234;
b=Iac*$test;
```

In this example **\$test** is not displayed, but only **b**.

4.4.4.2.5.2 Environment variables

These variables are accessible via the 'Env' ID as an array: **Env[0...7]**.

They are (in opposite to standard variables) not displayed, but they can (in opposite to local variables) be used externally (e.g. in the processing signal interface). Further on they can be set directly by the interface (see 10.2.2.1.1, 'ENVironment ENV Env').

4.4.4.2.6 Keywords

These are strings which are no variables or constants but which are used for controlling the script editor:

- if** The start of a conditioned program sequence. The condition have to follow in the round brackets.
- else** The end of the program sequence which is used if the condition of the **if** was true (no semicolon at the end!). All command after the **else** until the next **fi** are used, if the condition of the **if** was **not** true. The else is optional.
- fi** The end of the program sequence which is used if the condition of the **if** was true (no semicolon at the end!).

4.4.4.2.7 Functions

The following functions are implemented at the moment (x is the result of a valid expression, constant or function):

- abs (x)** absolute value of x
- acos (x)** arcus cosine of x (result in radiant!)
- asin (x)** arcus sine of x (result in radiant!)
- bell ()** generates a short sound with the internal speaker
- btst (x, bit_no)** Returns true, if in variable x bit number bit_no is set. The bits are counted from 1 to 32. You should only apply this function onto integer values like digital inputs or result of flicker measuring. Usually you should not use it with float numbers.
- cos (x)** cosine of x (argument in radiant!)
- digin (mask)** Returns the value of the digital inputs. The values are coded in one byte: input 1-4 correspond to bit 0-3 and input 7-10 to bit 4-7. So if the inputs 1 and 8 are active, the returned value would be 33. With mask you can define, which values are checked: With a mask of 32 only the input 8 is checked. In this case the return value can only be 32 or 0. The mask is useful when checking the status of one input, independent from the others. If you want to check all inputs, you should use a mask of 255!
- dout_off (nr)** Switches digital output number nr. off (into no-alarm state). $1 \leq nr \leq 4(8)$

<code>dout_on(nr)</code>	Switches digital output number <i>nr</i> on (into alarm state). $1 \leq nr \leq 4(8)$
<code>freeze()</code>	freezes the display (like key <i>Freeze</i>)
<code>isrun()</code>	Returns 1, if the integration is running
<code>isstop()</code>	Returns 1, if the integration is stopped
<code>ln(x)</code>	\log_e of <i>x</i>
<code>log(x)</code>	\log_{10} of <i>x</i>
<code>print()</code>	Prints the menu in which you started the logging in ‘by script’ mode (see 11.3.1, ‘Output intervals’).
<code>reset()</code>	Same like Reset Softkey in <i>Time Int.</i> menu
<code>scale_i(chn,x)</code>	Scale the current input, <i>chn.</i> is the number of the channel, <i>x</i> the scaling factor.
<code>scale_u(chn,x)</code>	Scale the voltage input, <i>chn.</i> is the number of the channel, <i>x</i> the scaling factor.
<code>sin(x)</code>	sine of <i>x</i> (argument in radiant!)
<code>sqrt(x)</code>	The square root of <i>x</i>
<code>start()</code>	Same like pressing <i>Start</i>
<code>stop()</code>	Same like pressing <i>Stop</i>
<code>unfreeze()</code>	reactivates the frozen display

4.4.4.2.8 Operators

Operators are symbols which cause actions, when they meet variables, constants or formulas. The script editor offers following operators, sorted by priority:

high priority

- : Channel separator, usually used only for multi channel devices (like analogue inputs). E.g. `ain:3` is the third analogue input channel.
- [] Index operator, used for indexed values (arrays), e.g. `v[5]` is the 5th harmonic of the voltage
- () Function call, the value inside the brackets is the parameter to the function

- Negation
- ^ Exponent
- / * Division and Multiplication
- + - Addition and Subtraction
- <, ==, > smaller, equal, bigger (comparator operators)
- = Assignment of a value
- <> not equal

low priority

If there are no brackets, the operators are used in the order listed above.

The result of:

$3^2 * 4$ is 36

$-(3^2) * -4$ is also 36

4.4.4.2.9 Remarks

Each line starting with a '#' is a remark. See '4.4.4.2.14 ,Example 5:Switching digital outputs, depending on harmonics'. Only the first '#' is important, the other don't care.

4.4.4.2.10 Example 1: Freeze at limit violation

If the 23rd harmonic of voltage of channel 1 is bigger than 10V the display should be frozen and the instrument should inform you with a sound.

```
if(Uh:1[23] > 10)
    freeze();
    bell();
fi
```

Attention!

The function `freeze()` can cause the display to freeze at the start-up of the instrument. So be careful when using this function.

4.4.4.2.11 Example 2: Getting min/max values

You want to measure the biggest and smallest TRMS values of the voltage.

```

if (Uhigh==0)
  Ulow=RngU:1;
fi
if (Uhigh<Utrms:1)
  Uhigh=Utrms:1;
fi
if (Ulow>Utrms:1)
  Ulow=Utrms:1;
fi

```

The first `if` condition is used for resetting the minimum value: With **Reset** it would be set to 0 which is not sufficient, because this is already the smallest TRMS value. So if the maximum TRMS value is reset to 0.0, the minimum value is set to the range value which will not be reached under proper conditions. The second and third condition compute the maximum and minimum value and store them in the variables `uhigh` and `ulow` which can be read out in the *Custom* menu.

4.4.4.2.12 Example 3: Calculating THD+N

You want to measure the total distortion factor including noise (THD+N) of the voltage of channel 2:

```
THDN=sqrt ( (Utrms:2^2-Uh:2[1]^2) /Uh:2[1]^2);
```

Please note that this will only work in the harmonic mode, because `uh:2[1]` is only calculated there!

4.4.4.2.13 Example 4: Counting pulses

You want to count the number of current pulses of a battery above 3A (the pulse width has to be bigger than twice the cycle time!)

```

ibat=abs(Idc:1);
if (ibat>3.0)
  if (r == 0)
    n=n+1;
    r=1;
  fi
fi
if (ibat < 3.0)
  r=0;
fi

```

4.4.4.2.14 Example 5: Switching digital outputs, depending on harmonics

```

### Wave1 ###
if(Ih:1[1]>0.08) dout_on(1);
else dout_off(1);
fi
### Wave3 ###
if(Ih:1[3]>0.068) dout_on(2);
else dout_off(2);
fi
### Wave5 ###
if(Ih:1[5]>0.05) dout_on(3);
else dout_off(3);
fi

```

The digital outputs 1 to 3 are switched on if the corresponding harmonic 1 to 5 is bigger than a defined value. In the other case the output is switched off.

4.4.4.2.15 Example 6: Calculation of the efficiency of a motor with torque and frequency input

For the measurement of the efficiency of a motor you can use the analogue and the frequency inputs. To input the torque of the motor use the analogue input (e.g. 1) and for the frequency use the digital frequency input (e.g. card1 Pin 12). For calculation of the efficiency you can use the following formula:

```
M=Ain:1;
n=DigFrq:1;
Pmech=M*n;
eta=Pmech/P:13*100;
```

Important Note: The motor frequency connected to the frequency input (No.1) has to be counted and scaled in Hz. Then you get a result in percent.

4.4.4.3 Printing scripts

You can printout the scripts you have set-up (see 11, 'Logging of values to drives, printer and interfaces'). Please note, that the complete script editor is printed out, not only the visible part.

4.4.4.4 Speed and torque calculation (option MotorTorque-SOFT)

This option provides two functions which calculate the values speed and torque from motor current and voltage. The motor must be a three phase asynchronous standard motors according IEC. There are just some information from type plate or catalogue data necessary. There is no need of a torque measuring shaft or a speed sensor. The motor can be connected to the lines or to a frequency converter.

Measuring uncertainty between no-load operation and 1.5 fold nominal torque typical below 2% of nominal torque resp. rotation speed for motors from 1kW to 100kW nominal power and rotation speed between -40% to +20% of nominal speed. The calculation is also possible with other nominal power, but with increased uncertainty.

For the calculation, following requirements must be met:

- Wiring
3+1, $U\Delta I^* \rightarrow U*I^*$
- Filter
Smaller than half clock frequency. So just the fundamental must be measured, the clock ripple must be rejected.
- Signal coupling
AC
- Sync
Such, that the fundamental frequency is displayed (e.g. I1, LP<300Hz)

The two functions are:

torque (Pn, fn, Un, In, pfn, pz, Rk, I3, mk)

Calculates the torque in Nm. The parameters are:

- Pn: Nominal output power in W
- fn: Nominal frequency in Hz
- Un: Nominal line line voltage of the motor in V
- In: Nominal current in A
- pfn: Nominal power factor
- pz: Number of poles (twice the number of pole pairs)
- Rk: Stator line-line copper resistance in Ω
- mk No load torque correction

speed (Pn, nn, fn, Un, In, pfn, pz, Rk, I3, mk)

Calculates the speed in min^{-1} . The parameters are:

- Pn: Nominal output power in W
- nn: Nominal speed in min^{-1}
- fn: Nominal frequency in Hz
- Un: Nominal line line voltage of the motor in V
- In: Nominal current in A
- pfn: Nominal power factor
- pz: Number of poles (twice the number of pole pairs)
- Rk: Stator line-line copper resistance in Ω
- mk No load torque correction

The copper resistance has to be measured at the same point, where the voltage is measured by the LMG. The advantage is, that you can measure for example from a cabinet and that the copper resistance of the wiring is included and by this eliminated from the calculation.

The results of `torque()` and `speed()` can be displayed in a user defined menu or transfered via an interface.

A typical script could look like this:

```
# M-n-calculation
# Detailed motor description
# 2.2kW Motor DDA 90 L
# Input of the motor parameters
$cn=0.84; # Nominal powerfactor
$nn=2845; # Nominal speed 1/min
$pz=2;    # Number of poles
          # (2* pole pairs)
```

```

$jn=4.66; # Nominal current in A
$un=400; # Nominal L-L voltage in V
$pn=2200; # Nominal output power in W
$fn=50; # Nominal frequency in Hz
$rk=19.7; # resistor in Ohm
          # terminal to terminal
          # (hot resistor)
$mk=20; # No load torque
M.Nm=torque($pn,$fn,$un,$jn,$cn,$pz,$rk,13,mk);
n=speed($pn,$nn,$fn,$un,$jn,$cn,$pz,$rk,13,mk);

```

No load torque correction

Set $mk=0$, enter all other data and make a no load measurement of the motor. Use the read out torque with opposite sign as new value for mk . By this tolerances of the motor nominal values are corrected.

4.4.5 Saving and restoring configurations

You can save up to 8 different set-ups for the instrument. With **Reset** you get the factory settings. Everything is reset, but not the 8 stored configurations.

4.4.5.1 Loading a configuration

After pressing *Save/Recall* you can load previously saved configurations. For this purpose choose the wanted one with the rotary knob and press **Recall**. All set-up values like range settings, scripts and measuring settings are restored. The actual settings are lost.

In the field 'Active configuration mod()' you see now the name of the selected configuration. If mod(*) is displayed, any of the settings are changed.

4.4.5.2 Saving the configuration

After pressing *Save/Recall* you can save the actual configuration. For this purpose choose the wanted position with the rotary knob and press **Save**. Now you have to specify a name for this entry (see chapter 4.5, 'Entering identifiers, characters and text'). If the entry exists, it will be overwritten. All setup values like range settings, scripts and measuring settings are saved.

4.5 Entering identifiers, characters and text

In some menus (e.g. in the plot menu or in the menu for the digital outputs) you have to enter an identifier or text to specify which value should be worked with (e.g. plotted).

If the cursor is at the first position and you press ←, the complete input field will be deleted.

If you have pressed the softkey to modify the identifier or text, you can either enter the desired value by moving the rotary knob (**Mode** has to be set to copy!) to the wished letter and press

Enter or the rotary knob. In this case you have to enter the letters in the same way you see them in the menus (e.g. 'Utrms'). Or you can press the key of any valid menu (e.g. *Voltage*, *Current*, ...) and you get a list of the available values (in this mode).

Following values are available in the different menus:

Normal measuring mode

Default	Current	Voltage	Power	Int. Value	Measure	Custom	Misc.	IF/IO
f	f	f	f	q	Aver	Env	abs()	Ain
Iac	Iac	OvrU	P	EP	DisCyc	var0-11	acos()	DigFrq
Icf	Icf	Uac	PF	EQ	Cycle		asin()	Zero
Idc	Idc	Ucf	PHI	Et	Mtime		bell()	
Idcn	Idcn	Udc	Q	ES	Rcyc		cos()	
Idcp	Idcp	Udcn	Rser	tsec			digin()	
Itrms	Itrms	Udep	S	Pm			dout_on()	
Iff	Iff	Utrms	Xser	Qm			dout_off()	
Iinr	Iinr	Uff	Z	Sm			freeze()	
Iphi	Iphi	Uphi					isrun()	
Ipkn	Ipkn	Upkn					isstop()	
Ipkp	Ipkp	Upkp					log()	
Ipp	Ipp	Upp					ln()	
Irect	Irect	Urect					reset()	
RngI	RngI	RngU					scale_i()	
Iscal	Iscal	Uscal					scale_u()	
Env	OvrI						sin()	
OvrI							sqrt()	
OvrU							start()	
P							stop()	
PF							unfreeze()	
PHI							if());fi	
Q							2.7182818 (e)	
Rser							3.1415927 (π)	
S							1.2566e-6 (μ_0)	
Uac							8.854e-12 (ϵ_0)	
Ucf								
Udc								
Udcn								
Udep								
Utrms								
Uff								
Uphi								
Upkn								
Upkp								
Upp								
Urect								

Default	Current	Voltage	Power	Int. Value	Measure	Custom	Misc.	IF/IO
RngU								
Uscal								
var0-11								
Xser								
Z								

prCE Harmonic measuring mode

Default	Current	Voltage	Power	Measure	Custom	Misc.	IF/IO
f	f	f	f	Per	Env	abs()	Ain
Ih	Ih	Uh	Ph	Mtime	var0-11	acos()	DigFrq
Imav	Imav	Uthd	Pav			asin()	Zero
Iav	Iav	UL	PFm			bell()	
Ifm	Ifm	UMax	Qh			cos()	
Ithd	Ithd	UP	Sh			digin()	
IL	IL	OvrU	P			dout_on()	
Im	Im	Utrms	PF			dout_off()	
IP	IP	RngU	Q			freeze()	
Ipohl	Ipohl		Rser			isrun()	
Ph	Ipohc		S			isstop()	
Pav	Ithc		Xser			log()	
PFm	Itrms		Z			ln()	
Ipohc	RngI					reset()	
Qh	Iscal					scale_i()	
Sh	OvrI					scale_u()	
Ithc						sin()	
Uh						sqrt()	
Uthd						start()	
UL						stop()	
UMax						unfreeze()	
UP						if();fi	
Itrms						2.7182818 (e)	
RngI						3.1415927 (π)	
Iscal						1.2566e-6 (μ_0)	
Env						8.854e-12 (ϵ_0)	
OvrI							
OvrU							
P							
PF							
Q							
Rser							
S							
Utrms							
RngU							
Uscal							
var0-11							

Default	Current	Voltage	Power	Measure	Custom	Misc.	IF/IO
Xser							
Z							

CE Flicker measuring mode

Default	Current	Voltage	Power	Int. Value	Measure	Custom	Misc.	IF/IO
Uhwcf	f	Uhwcf	Phw	Uhwcf	Per	Env	abs()	Ain
dcl	dcs	dcl	f	dcl	Mtime	var0-11	acos()	DigFrq
dtl	dtl	dtl	P	dmaxl	FlkPer		asin()	Zero
dmaxl	dmaxs	dmaxl	PF	Pltl			bell()	
Pltl	Plts	Pltl	Q	Pmoml			cos()	
Pmoml	Pms	Pmoml	Rser	Pstl			digin()	
Pml	Pmoms	Pml	S	Upkph			dout_on()	
Phw	Uhws	Phw	Xser				dout_off()	
Uhwl	Psts	Uhwl	Z				freeze()	
Pstl	Ithd	Pstl					isrun()	
Upkph	Itrms	Upkph					isstop()	
f	RngI	f					log()	
dcs	Iscal	Uthd					ln()	
dtl	OvrI	OvrU					reset()	
dmaxs		Utrms					scale_i()	
Plts		RngU					scale_u()	
Pms		Uscal					sin()	
Pmoms							sqrt()	
Uhws							start()	
Psts							stop()	
Ithd							unfreeze()	
Uthd							if();fi	
Itrms							2.7182818 (e)	
RngI							3.1415927 (π)	
Iscal							1.2566e-6 (μ_0)	
Env							8.854e-12 (ϵ_0)	
OvrI								
OvrU								
P								
PF								
Q								
Rser								
S								
Utrms								
RngU								
Uscal								
var0-11								
Xser								
Z								

HARM100 measuring mode

Default	Current	Voltage	Power	Measure	Custom	Misc.	IF/IO
D	f	f	D	Per	Env	abs()	Ain
f	Ih	Uh	f	Mtime	var0-11	acos()	DigFrq
Ih	Ithd	Uthd	Ph			asin()	Zero
Ithd	IP	UP	Qh			bell()	
IP	Itrms	Utrms	Sh			cos()	
Ph	RngI	RngU	P			digin()	
Qh	Iscal	Uscal	PF			dout_on()	
Sh	OvrI	OvrU	Q			dout_off()	
Uh			Rser			freeze()	
Uthd			S			isrun()	
UP			Xser			isstop()	
Itrms			Z			log()	
RngI						ln()	
Iscal						reset()	
Env						scale_i()	
OvrI						scale_u()	
OvrU						sin()	
P						sqrt()	
PF						start()	
Q						stop()	
Rser						unfreeze()	
S						if();fi	
Utrms						2.7182818 (e)	
RngU						3.1415927 (π)	
Uscal						1.2566e-6 (μ_0)	
var0-11						8.854e-12 (ϵ_0)	
Xser							
Z							

Select one value with the rotary knob and press *Enter* or the rotary knob to copy the list item into the edit line. If you have a multi channel value (e.g. analogue inputs) you have to enter a ‘:’ behind this value and then the number of the channel (e.g. the identifier for the analogue input 3 would be ‘Ain:3’). If you don’t specify this number, ‘1’ is the default value. Confirm your choice with *Enter*.

If the value is an array value, the desired index is entered in brackets ‘[’ and ‘]’ (example the 5th harmonic of the voltage would be Uh[5]). You can also combine this values: Uh:2[5] would be the 5th harmonic of the voltage of the second channel. If you don’t specify this number, ‘0’ is the default value. Confirm your choice with *Enter*.

To select another position in the text, you have to set **Mode** to 'move' or 'line'. With 'move' you move character by character, with 'line' you move line by line, which is much faster in bigger text.

With **new line** you can insert a linefeed (if you have a multi line input box). Especially in conjunction with the script editor you can reach a list of useful functions and operators by pressing *Misc*.

Finally close you inputs with **End**.

4.6 Entering numerical values

If you have entered a value by the numerical keypad and move the cursor to the right end and move the rotary knob to the right then the modifiers 'μ', 'm', 'k' and 'M' appear. So it is more simple to enter big or small values.

5 Normal measuring mode

In the normal measuring mode the LMG450 works as a four channel power meter. The voltage, current and power are measured directly, many other values are derived from these values.

5.1 Measuring configuration (Measuring)

When you have come to this menu by pressing *Measure* you first have to choose **Norm(a)** to enter this mode. With the rotary knob you can select three tabs ('Globals', 'Group A' and 'Group B'). Pressing the rotary knob, you can do several settings in each tab.

5.1.1 Globals tab

Here you setup all values which are global to the instrument (independent from the groups).

Cycle Here the cycle time in seconds is defined. Valid values are from 0.05s to 60s. Any value in steps of 10ms is allowed. A value of 0ms defines the external cycle time. See chapter '14.1.1, External Synchronisation (Sync.)' and following.

During every cycle time the values of voltage, current and power are measured. At the end of each interval the measured values are computed to the displayed values. The cycle time has always to be bigger or same like the (fundamental or basic) period time of the signal.

Aver Here you can setup, how many measuring cycles are averaged for the display. For example: If you choose 5 cycles, the display will always be averaged over the last 5 cycles (sliding average!).

Wire Here you can setup, with which wiring you want to measure. Please see chapter 2.4, 'The group concept' for further details.

Aron This point is only available when you have chosen wiring 'A:1+2 B:3+4'.

If you connect a 3 phase 3 wire system in aron circuit (see chapter 3.3.5, 'Measuring circuit for measuring efficiency of 3/3phase systems') you have to measure the voltages U_{12} and U_{32} . U_{31} is calculated by the instrument. But usually you would use the three voltages U_{12} , U_{23} and U_{31} . So you measure U_{32} instead of U_{23} with $U_{32} = -U_{23}$. For most values this does not matter, but in the scope display, you would see, that U_{32} has not 120° against U_{12} but 60° . This is physically correct (you see the voltages connected to the instrument), but this is not what you expected. So if you switch the **Aron** setting to 'on' the display of U_{32} is inverted, so that you see U_{23} .

Only in the case you have a real 2 phase 3 wire system, you should set **Aron** to 'off'

to see the real phase shift between the phases.

The voltage measured with the third channel is also inverted.

5.1.2 Group A/B tab

The settings in group A and B are identical, so they are just described once. Each setting influences all channels which belong to the group!

Sync Selects the signal which is used for synchronisation of all channels belonging to this group. There are following possible settings:

U The voltage signal is used (channel 1 in group A and channel 4 in B)

I The current signal is used (channel 1 in group A and channel 4 in B)

X Extended Trigger. See **Xtrig**.

Line The line signal is used

Extn The signal at the external synchronisation jack is used.

Depending on the value of **Sync** there is one softkey which changes from **Xtrig** (setting 'X') to **Coupl** (all other settings).

Coupl Selects how the voltage or current signal is coupled to the following trigger stage.

This setting has **no** influence on the measured signals!

AC+DC	The signal is directly coupled, including all signal parts.
LP<80Hz	Low Pass Filter. Only the signal components below 80Hz are used
LP<300Hz	Low Pass Filter. Only the signal components below 300Hz are used. <u>This is very useful, when measuring frequency converters with fundamental frequencies below 300Hz and clock frequencies above 300Hz.</u>
HP>10Hz	High Pass Filter. Only the signal components above 10Hz are used. This is useful to reject a DC component in the signal.
HP>30Hz	High Pass Filter. Only the signal components above 30Hz are used. This is useful to reject a DC component in the signal.
BP 10-300Hz	Band Pass Filter. Only the signal components between 10Hz and 300Hz are used.
BP 30-80Hz	Band Pass Filter. Only the signal components between 30Hz and 80Hz are used. This is useful when synchronising to line frequent signals with very much distortion.
AM 10-300Hz	Amplitude (De)Modulation. The signal will be demodulated when measuring AM signals. Only the envelope between 10Hz and 300Hz is used. This is useful, when measuring electronic gears or transformers.

Xtrig Here you reach a menu where you can define very precise, what should be your trigger condition. This menu should only be used from very experienced users, because if you select wrong conditions, you might get wrong measuring results.

- Signl** Here you define the signal you want to trigger on. Available are: u, i, p, u^2 , i^2 , u_{filt} , i_{filt} , p_{filt} . For the meaning of this values please watch the functional diagram in 14.5, 'Functional block diagram computing unit'
- Filt** Here you can define a digital filter which influences the signal to be triggered on. Please note 2 points:
1. For Example: You have a 50Hz signal and select p, you have a 100Hz p-wave! So a 87.5Hz filter will influence this trigger signal!!!
 2. You should always try to switch the hf rejection filter on (see point **Filter/S-Cpl, Filt** below) to prevent distortions on the trigger signal. Especially when using frequency converters this hf rejection filter should be switched on.
- Level** Here you select the trigger level. If you for example select 'u' and a level of 100.0 the instrument will be triggered each time the voltage crosses the 100V line. Please note: If you select u^2 the level is $100V^2$ and you trigger if $|u| > 10V!!$
- Hyst** Usually you have a small noise on the signal. Without a hysteresis you might get several level crossings at a single 'real' crossing. With the hysteresis you can prevent this. For example you have a **Level** of 100V and a **Hyst** of 5V. If your signal comes from a value smaller than 95V it has to climb up to 105V to get a positive crossing. If it comes from a value greater than 105V it has to fall below 95V to get a negative crossing.
- back** returns to the last menu.

What can you do with this very special trigger mode?

If you have signals with a big DC part and a quiet small AC part (e.g. pulsed loads with DC supply) you have the problem to trigger on the frequency of the AC part. The solution is, to set the **Level** to a value of about the DC part, so you get a good trigger level.

Another example is to measure pulse controlled currents. In fact this signals are AM signals with a 50Hz carrier and for example a 1.5Hz modulator. To get correct measuring results you would have to trigger on the 1.5Hz signal. To do this you just select 'i*i' as source and a 30Hz filter. So you have built up a quadratur demodulator. Now you select a trigger level (depending on the current) and your instrument will synchronise to the 1.5Hz signal of your pulse control.

- Filt** Here you can switch on/off the filters in the measuring signal path of voltage and current. This filters are only in the signal way (they influence the sampling values) and don't influence the synchronisation settings 'U' and 'I'. But they influence the synchronisation **Xtrig** because it is using the sampling values! Possible settings are:

Setting	Meaning
off	All filters are switched off
HF-Rej	The analogue HF rejection filter is switched on. <u>Especially when using frequency converters this HF rejection filter should be switched on.</u>
30Hz	Additionally to the HF rejection filter a digital Low-Pass Filter with a cut off frequency of about 30Hz is used
60Hz	Additionally to the HF rejection filter a digital Low-Pass Filter with a cut off frequency of about 60Hz is used
87.5Hz	Additionally to the HF rejection filter a digital Low-Pass Filter with a cut off frequency of about 87.5Hz is used
175Hz	Additionally to the HF rejection filter a digital Low-Pass Filter with a cut off frequency of about 175Hz is used
1.4kHz	Additionally to the HF rejection filter a digital Low-Pass Filter with a cut off frequency of about 1.4kHz is used
2kHz	Additionally to the HF rejection filter a digital Low-Pass Filter with a cut off frequency of about 2kHz is used
2.8kHz	Additionally to the HF rejection filter a digital Low-Pass Filter with a cut off frequency of about 2.8kHz is used
6kHz	Additionally to the HF rejection filter a digital Low-Pass Filter with a cut off frequency of about 6kHz is used
9.2kHz	Additionally to the HF rejection filter a digital Low-Pass Filter with a cut off frequency of about 9.2kHz is used
18kHz	Additionally to the HF rejection filter a digital Low-Pass Filter with a cut off frequency of about 18kHz is used

Especially when using frequency converters this HF rejection filter should be switched on.

S-Cpl Here you define the signal coupling. This setting has **no** influence to the trigger signal!

Possible settings are:

AC+DC: All parts of the signal are taken into calculation.

AC Only the AC parts of the signal are taken into calculation. The DC part is separated. Please note, that this separation is done by software after the measuring and not by hardware! So you don't have any advantages concerning the measuring range and no influence to the scope values. The advantage of this coupling mode is the better uncertainty, because all DC uncertainties are eliminated.

back returns you to main menu.

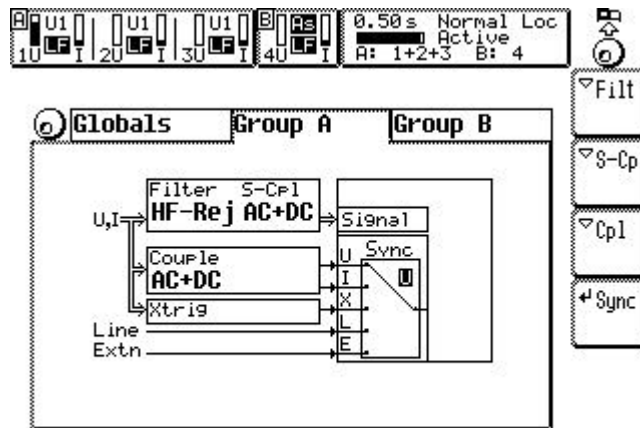

Figure 23: Measuring menu in normal mode

5.2 Measuring ranges (Range)

When you came to this menu by pressing *Range* you can setup all the ranges and scalings for the different measuring channels. You see three tabs ('Group A', 'Group B' and 'Sense/More').

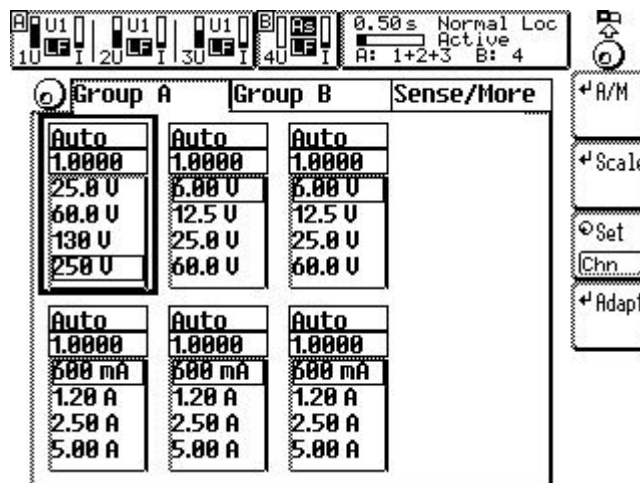

Figure 24: Range menu

5.2.1 Group A/B tab

The settings in group A and B are identical, so they are just described once.

A/M With **A/M** the automatic or manual range setting is selected. This is only possible in the normal measuring mode. In all other modes the manual range is selected.

Scale The **Scale** button allows you to enter a scaling factor. With this scaling factor all values of this channel (and the power) are multiplied. This setting is usually used to enter the transformer ratio of current clamps or voltage transformers.

Example 1:

You have a current clamp with 1000A/1A ratio. In this case enter 1000 as scaling

factor.

Example 2:

You have a current clamp with 1A/10mV ratio. This is equal to 100A/V, so you have to enter 100 as scaling.

Set Here you define the action of the rotary knob. You can change between the different channels ('Chn') or you can change the range in the selected channel ('Rng').

Adapt By this you force all channels of this group to work with the same settings like the actual one. If the actual one works in automatic mode all other work also in automatic mode. In manual mode all channels get the same range. Please note, that the scaling is not adapted! The reason is, that sometimes the scaling factor is used to adjust an external sensor. If the scaling would also be adapted, the adjustment would be lost.

By pressing the rotary knob again you leave the set mode and can select another tab.

5.2.2 Sense/More tab

Here you get information about the connected external current sensors. If they are connected, you get automatically a new list of current ranges (depending on the connected sensor).

Use allows you to activate or deactivate an external sensor. You have to select the sensor with the rotary knob and then to press the softkey.

How to connect your own current sensor please refer chapter „14.1.2“.

Some notes for auto ranging

There are some special points you have to know, when using the auto range function:

- If you want to measure a single peak value never use the auto range function. The reason for this is, that the autorange function does not detect a too low range until it is overloaded! When it is overloaded and the range is changed, the last measurement might be invalid.
- Do not use the auto range function for very precise measurements. While a measurement you don't directly see which range is actually selected. Afterwards it is not possible to say what was the selected range and therefore you can't make an uncertainty calculation.
- Do not use the autorange function for measurings without gaps (e.g. energy, harmonics or flicker). The reason for this is the setup time of the measuring channels after a range change.

5.3 Definition of measuring values

Following you find the definitions for all measuring values in the normal operation mode. The values are divided in two sections:

- The values from single measuring are measured while one measuring cycle and are independent from all other measuring cycles.
- The integrated values are calculated over several cycles.

The following basic definitions are used:

$u(t)$ The instantaneous value if the voltage used for calculation

$i(t)$ The instantaneous value if the current used for calculation

T The time of an integer number of the periods of the synchronisation signal. The integer factor depends on the chosen measuring cycle time. This time can vary from cycle to cycle! T is the real measuring time.

The values $u(t)$ and $i(t)$ used for calculation can be the directly in channel n measured values $u_n(t)/i_n(t)$ or calculated from them (depending on the wiring and the selected display channel):

Wiring '4+0 Channels'

Display channel	$u(t)$	$i(t)$
1	$u_1(t)$	$i_1(t)$
2	$u_2(t)$	$i_2(t)$
3	$u_3(t)$	$i_3(t)$
4	$u_4(t)$	$i_4(t)$

Wiring '3+1 Channels'

Display channel	$u(t)$	$i(t)$
1	$u_1(t)$	$i_1(t)$
2	$u_2(t)$	$i_2(t)$
3	$u_3(t)$	$i_3(t)$
4	$u_4(t)$	$i_4(t)$

Wiring '2+2 Channels'

Display channel	$u(t)$	$i(t)$
1	$u_1(t)$	$i_1(t)$
2	$u_2(t)$	$i_2(t)$
3	$u_3(t)$	$i_3(t)$
4	$u_4(t)$	$i_4(t)$

Display channel	$u(t)$	$i(t)$
5	$-u_1(t)+u_2(t)$	$-i_1(t)-i_2(t)$
6	$-u_3(t)+u_4(t)$	$-i_3(t)-i_4(t)$

For further information about the tables see also chapter 2.4, ‘The group concept’.

Linked values

If you have installed the option L45-O6 (star to delta conversion) you get the following additional wirings. The values in the column ‘Measuring channel numbers’ define the internal calculation of the DSPs (the numbers are the numbers of the measuring channels!!). The column ‘Circuit number’ defines the physical values of your circuit. This relations are correct, if you connect your instrument in the correct way. For this refer to the measuring circuit chapter below each table.

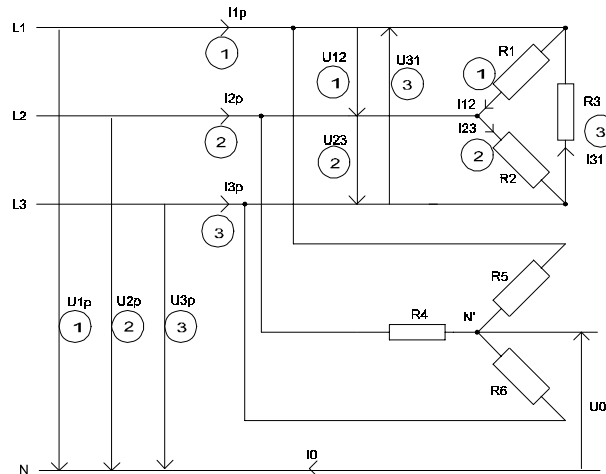

Figure 25: Allocation of the different linked values

Please not also the hints and restrictions given in 2.5, ‘Linked values, star to delta conversion (option L45-O6)’.

Wiring '3+1, U*I*-> UΔIΔ'

	Measuring channel numbers		Circuit numbers	
Display channel	u(t)	i(t)	U	I
1	$u_1(t)$	$i_1(t)$	U1	I1
2	$u_2(t)$	$i_2(t)$	U2	I2
3	$u_3(t)$	$i_3(t)$	U3	I3
4	$u_4(t)$	$i_4(t)$	U4	I4
5	$u_1(t)-u_2(t)$	$\frac{i_1(t) - i_2(t)}{3}$	U12	I12
6	$u_2(t)-u_3(t)$	$\frac{i_2(t) - i_3(t)}{3}$	U23	I23
7	$u_3(t)-u_1(t)$	$\frac{i_3(t) - i_1(t)}{3}$	U31	I31

For circuit see 3.3.2, 'Measuring circuit for measuring efficiency of 3/1phase systems'

Wiring '3+1, UΔI*-> UΔIΔ'

	Measuring channel numbers		Circuit numbers	
Display channel	u(t)	i(t)	U	I
1	$u_1(t)$	$i_1(t)$	U12	I1
2	$u_2(t)$	$i_2(t)$	U23	I2
3	$u_3(t)$	$i_3(t)$	U31	I3
4	$u_4(t)$	$i_4(t)$	U4	I4
5	$u_1(t)$	$\frac{i_1(t) - i_2(t)}{3}$	U12	I12
6	$u_2(t)$	$\frac{i_2(t) - i_3(t)}{3}$	U23	I23
7	$u_3(t)$	$\frac{i_3(t) - i_1(t)}{3}$	U31	I31

For circuit see 3.3.3, 'Measuring circuit (typical) for star to delta conversion (option L45-O6)'

Wiring '3+1, UΔI*-> U*I*'

	Measuring channel numbers		Circuit numbers	
Display channel	u(t)	i(t)	U	I
1	$u_1(t)$	$i_1(t)$	U12	I1
2	$u_2(t)$	$i_2(t)$	U23	I2

Display channel	Measuring channel numbers		Circuit numbers	
	u(t)	i(t)	U	I
3	$u_3(t)$	$i_3(t)$	U31	I3
4	$u_4(t)$	$i_4(t)$	U4	I4
5	$\frac{u_1(t) - u_3(t)}{3}$	$i_1(t)$	U1	I1
6	$\frac{u_2(t) - u_1(t)}{3}$	$i_2(t)$	U2	I2
7	$\frac{u_3(t) - u_2(t)}{3}$	$i_3(t)$	U3	I3

For circuit see 3.3.3, 'Measuring circuit (typical) for star to delta conversion (option L45-O6)'

Wiring '2+2, UΔI*-> UΔIΔ'

Display channel	Measuring channel numbers		Circuit numbers	
	u(t)	i(t)	U	I
1	$u_1(t)$	$i_1(t)$	U13	I1
2	$u_2(t)$	$i_2(t)$	U23	I2
3	$u_3(t)$	$i_3(t)$	U13'	I1'
4	$u_4(t)$	$i_4(t)$	U23'	I2'
5	$-u_1(t)+u_2(t)$	$-i_1(t)-i_2(t)$	U12	I3
6	$-u_3(t)+u_4(t)$	$-i_3(t)-i_4(t)$	U12'	I3'
7	$u_1(t)$	$\frac{i_2(t) + 2i_1(t)}{3}$	U12	I12
8	$-u_2(t)$	$\frac{-i_1(t) - 2i_2(t)}{3}$	U23	I23
9	$u_2(t)-u_1(t)$	$\frac{i_2(t) - i_1(t)}{3}$	U31	I31
10	$u_3(t)$	$\frac{i_4(t) - 2i_3(t)}{3}$	U12'	I12'
11	$-u_4(t)$	$\frac{-i_3(t) - 2i_4(t)}{3}$	U23'	I23'
12	$u_4(t)-u_3(t)$	$\frac{i_4(t) - i_3(t)}{3}$	U31'	I31'

For circuit see 3.3.5, 'Measuring circuit for measuring efficiency of 3/3phase systems'

Wiring '2+2, UΔI*-> U*I*'

Display channel	Measuring channel numbers		Circuit numbers	
	u(t)	i(t)	U	I
1	u ₁ (t)	i ₁ (t)	U13	I1
2	u ₂ (t)	i ₂ (t)	U23	I2
3	u ₃ (t)	i ₃ (t)	U13'	I1'
4	u ₄ (t)	i ₄ (t)	U23'	I2'
5	-u ₁ (t)+u ₂ (t)	-i ₁ (t)-i ₂ (t)	U12	I3
6	-u ₃ (t)+u ₄ (t)	-i ₃ (t)-i ₄ (t)	U12'	I3'
7	$\frac{2u_1(t) - u_2(t)}{3}$	i ₁ (t)	U1	I1
8	$\frac{-u_2(t) - u_1(t)}{3}$	-i ₁ (t)-i ₂ (t)	U2	I2
9	$\frac{2u_2(t) - u_1(t)}{3}$	i ₂ (t)	U3	I3
10	$\frac{2u_3(t) - u_4(t)}{3}$	i ₃ (t)	U1'	I1'
11	$\frac{-u_4(t) - u_3(t)}{3}$	-i ₃ (t)-i ₄ (t)	U2'	I2'
12	$\frac{2u_4(t) - u_3(t)}{3}$	i ₄ (t)	U3'	I3'

For circuit see 3.3.5, 'Measuring circuit for measuring efficiency of 3/3phase systems'.

For further information about the tables see also chapter 2.5, 'Linked values'.

5.3.1 Values from single measuring**Voltage and current**

true root mean square: $U_{rms} = \sqrt{\frac{1}{T} \int_{t=0}^T u(t)^2 dt}$

$$I_{rms} = \sqrt{\frac{1}{T} \int_{t=0}^T i(t)^2 dt}$$

DCn negative DC component:

$$U_{dcn} = \frac{1}{T} \int_{t=0}^T \left\{ \begin{array}{l} u(t) \text{ for } u(t) < 0 \\ 0 \text{ for } u(t) \geq 0 \end{array} \right\} dt$$

$$I_{dcn} = \frac{1}{T} \int_{t=0}^T \left\{ \begin{array}{l} i(t) \text{ for } i(t) < 0 \\ 0 \text{ for } i(t) \geq 0 \end{array} \right\} dt$$

DCp positive DC component:

$$U_{dcp} = \frac{1}{T} \int_{t=0}^T \left\{ \begin{array}{l} u(t) \text{ for } u(t) \geq 0 \\ 0 \text{ for } u(t) < 0 \end{array} \right\} dt$$

$$I_{dcp} = \frac{1}{T} \int_{t=0}^T \left\{ \begin{array}{l} i(t) \text{ for } i(t) \geq 0 \\ 0 \text{ for } i(t) < 0 \end{array} \right\} dt$$

DC component:

$$U_{dc} = \frac{1}{T} \int_{t=0}^T u(t) dt$$

$$I_{dc} = \frac{1}{T} \int_{t=0}^T i(t) dt$$

AC component:	$U_{ac} = \sqrt{U_{trms}^2 - U_{dc}^2}$	$I_{ac} = \sqrt{I_{trms}^2 - I_{dc}^2}$
peak-peak value:	$U_{pp} = \max(u(t)) - \min(u(t))$	$I_{pp} = \max(i(t)) - \min(i(t))$
rectified value:	$U_{rect} = \frac{1}{T} \int_{t=0}^T u(t) dt$	$I_{rect} = \frac{1}{T} \int_{t=0}^T i(t) dt$
crest factor:	$U_{cf} = \frac{U_{pk}}{U_{trms}}$	$I_{cf} = \frac{I_{pk}}{I_{trms}}$
form factor:	$U_{ff} = \frac{U_{trms}}{U_{rect}}$	$I_{ff} = \frac{I_{trms}}{I_{rect}}$
Inrush current:	$I_{inr} = \max(i(t))$	

Power

active power:	$P = \frac{1}{T} \int_{t=0}^T u(t)i(t) dt$
reactive power	$Q = \sqrt{S^2 - P^2}$
apparent power:	$S = U_{trms} * I_{trms}$
power factor:	$PF = \lambda = \frac{ P }{S}$

Behind the power factor might be a 'i' or 'c' showing, that the load is inductive or capacitive. This decision is only done under following conditions:

$$\lambda < 0.999 \text{ and } 1.05 < U_{ff} < 1.2 \text{ and } 1.05 < I_{ff} < 1.2 \text{ and } f < 1\text{kHz}$$

This means, that voltage and current are nearly sinusoidal. In all other cases there is neither 'i' nor 'c'.

Please note: The i/c indication was developed for usual line applications. When the usage of the channels is very low or you work with very high frequencies you should take care, if the i/c indication is correct or not.

angle:	$\varphi = \arccos \lambda \text{ with } \varphi = \varphi_{ui} = \varphi_u - \varphi_i$
--------	--

The sign of the angle is derived from the i/c indication, '+' for an inductive load, '-' for a capacitive one. Here the current is the reference. This value is only valid at sinusoidal wave forms! The value can be in the range $\pm 180^\circ$, values outside $\pm 90^\circ$ usually indicate negative active power.

Impedances

apparent impedance: $Z = \frac{U_{rms}}{I_{rms}}$

active impedance: $R_{ser} = \frac{P}{I_{rms}^2}$

reactive impedance $X_{ser} = \frac{Q}{I_{rms}^2}$

5.3.2 Integrated values

The following basic definitions are used:

n The value from the measuring cycle number n .

N Is the number of measuring cycles for the integration. This number depends on the real measuring times and on the desired integration time.

Energy

active energy: $EP = \sum_{n=0}^N P_n * T_n$

reactive energy: $EQ = \sum_{n=0}^N Q_n * T_n$

apparent energy $ES = \sum_{n=0}^N S_n * T_n$

Average values

average active power: $P_m = \frac{EP}{\sum_{n=0}^N T_n}$

average reactive power: $Q_m = \frac{EQ}{\sum_{n=0}^N T_n}$

average apparent power $S_m = \frac{ES}{\sum_{n=0}^N T_n}$

Miscellaneous

charge: $q = \sum_{n=0}^N I_{dc_n} * T_n$

integration time: $t = \sum_{n=0}^N T_n$

5.3.3 Total values

This are values which are calculated over several channels of one group. Following symbols are used:

- f first channel of the group
- l last channel of the group
- s number of the display channel for the total values

These three symbols depend on the wiring. Please refer to 2.4, 'The group concept' and 2.5, 'Linked values' for details

Following values are calculated for the total values display channels (all other values are invalid):

collective sum voltage:
$$U_{s_{TRMS}} = \sqrt{\sum_{n=f}^l U_{n_{TRMS}}^2}$$

collective sum current:
$$I_{s_{TRMS}} = \sqrt{\sum_{n=f}^l I_{n_{TRMS}}^2}$$

active power:
$$P_s = \sum_{n=f}^l P_n$$

apparent power:
$$S_s = U_s * I_s$$

reactive power:
$$Q_s = \sqrt{S_s^2 - P_s^2}$$

power factor:
$$\lambda_s = \frac{|P_s|}{S_s}$$

frequency:
$$f_s = f_f$$

active energy:
$$EP_s = \sum_{n=0}^N P_s T_n$$

reactive energy:
$$EQ_s = \sum_{n=0}^N Q_s T_n$$

apparent energy:
$$ES_s = \sum_{n=0}^N S_s T_n$$

average active power:
$$Pm_s = \frac{EP_s}{\sum_{n=0}^N T_n}$$

$$\text{average reactive power: } Qm_s = \frac{EQ_s}{\sum_{n=0}^N T_n}$$

$$\text{average apparent power: } Sm_s = \frac{ES_s}{\sum_{n=0}^N T_n}$$

All this calculation are in accordance with DIN40110.

5.4 Display of values

For the display of the values you can choose several menus. Also in this menu we have the group concept. With the rotary knob you can select the desired group. Now you can have four softkeys (maybe not all appear, depending on the selected wiring, the group and installed options):

- Chns** By this you can select, which channel you want to see. A second softkey bar appears, where you can select the channel.
- Link** Here you can select which linked channel you want to see (only if option L45-O6 star to delta conversion is installed).
- Sum** Here you can select the total values of the group (over several channels).
- Displ** Here you can setup if you want to see few values in a big font or more values in a smaller font. This softkey may be inactive, if you watch several channels.

Above the displayed values you see a header which describes in several fields, what you see:

- Chnx** You see the values from the measuring channel x. This is always a measuring channel from the rear side of the instrument.
- Linkxy** You see the values of a linked channel. xy are the channels which are used to calculate the value.
- SUM(x-y)** You see the values of a sum channel. x and y are the first and last channels which are used to calculate the value
- (x,y)** This field is optional. It shows you, which values of your circuit are displayed on this channel.
- n:x** It belongs to group n. x is the number of the display channel. You have to use this number (together with the ‘:’) for example in the script editor or in the computer interface.

The following examples exist if you have the wiring 'A:1+2 B:3+4' and the Aron field is switched on in the measuring menu.

Example: Chn2 (U23,I2) A:2

This is the measuring channel 2. It should be connected to U23 and I2 of your circuit. It belongs to group A and has the display channel number 2.

Example: Link34 (U12,I3) B:6

This is a linked channel, which is calculated from values of channel 1 and 2. The displayed values represent U12 and I3 of your circuit. It belongs to group B and has the display channel number 6.

Example: Sum(1-2) A:13

This is the sum channel which is calculated over the display channels 1 to 2. It belongs to group A and has the display channel number 13.

For further information please refer also 2.4, 'The group concept' and 2.5, 'Linked values'.

5.4.1 Default

With *Default* you see the most important values of the instrument. For the handling please see the general description in chapter 5.4, 'Display of values'.

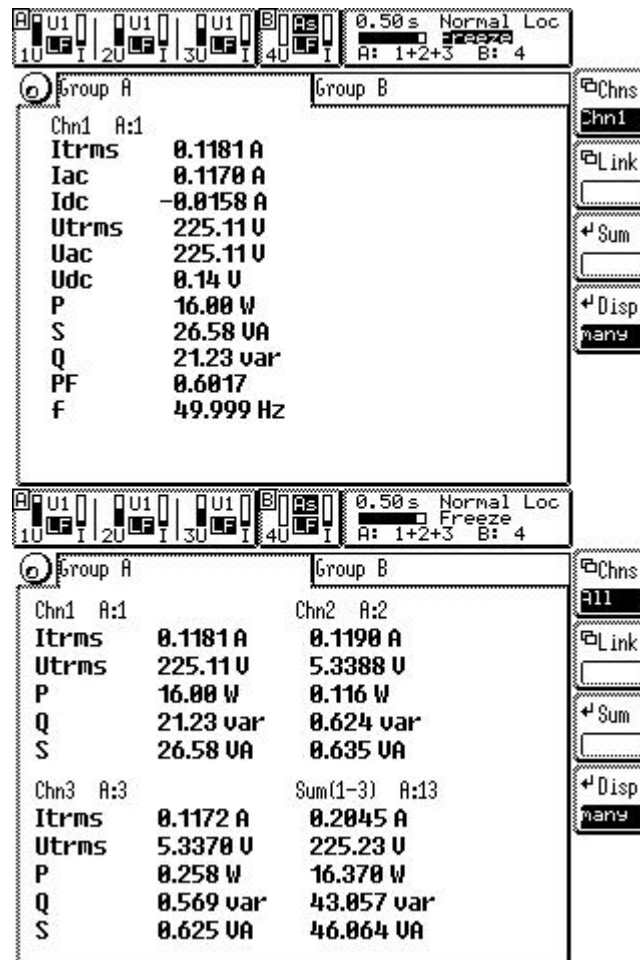

Figure 26: Default display with one and four channels

5.4.2 Voltage

With *Voltage* you see the most important voltage values of the instrument. For the handling please see the general description in chapter 5.4, 'Display of values'.

5.4.3 Current

With *Current* you see the most important current values of the instrument. For the handling please see the general description in chapter 5.4, 'Display of values'. With the **Inrsh** key you can reset the last measured inrush current to 0. This softkey is only available when the manual measuring range is selected for the current and the voltage! The average in the measuring menu has to be set to 1! If the inrush current is too big for the measuring range, a dashed line is displayed.

5.4.4 Power

With *Power* you see the most important power values of the instrument. For the handling please see the general description in chapter 5.4, 'Display of values'. Further on you get the

following resistor values: Z, X and R. **Please note that the values of X and R are only correct, if the voltage and current have a sinusoidal waveform!**

5.4.5 Energy

In this menu (you reach it by *Int. Val*) you see the most important energy values as well as derived values which also depend on time. For the handling please see the general description in chapter 5.4, 'Display of values'.

5.4.5.1 Integration menu

In this menu (you reach it by *Int. Time*) you defines the measuring conditions for time depending signals. **Reset** sets the display values to their default state (i.e. 0 for all energy values). This is only possible if the state is 'Hold'.

Mode Defines the integration mode. You can only change the mode, if the state is 'RESET'.

off	No integration can be done.
continuous	After the integration is started it measures continuously until <i>Stop</i> is pressed. With the start of this measurement the values are automatically reset to 0.
interval	After the integration is started it measures continuously until the interval DUR is over. With the start of this measurement the values are automatically reset to 0.
periodic	Same like 'interval', but with two differences: <ul style="list-style-type: none"> - At the end of one interval a new one is started. - The display is only updated at the end of an interval and not after every cycle.
summing	After the integration is started it measures continuously until <i>Stop</i> is pressed. With the start of the integration the values are NOT reset to 0!

Start Time,

Start Date This are the start time and date of an integration. You have to press *Start* to change the state of the integration changes to 'wait'. If the entered time is reached, the integration starts.

DUR This is the time of the time interval in interval and periodic integration mode.

Runtime is the running integration time. Please note, that this time can be smaller than the real time, for example because of invalid measuring cycles while a change in the measuring ranges.

Start of integration

In general there are three ways to start an integration. You can either enter a start time with **Start Time, Start Date**, or you can simply press the *Start* button or you can start via the external sync jack of the LMG450 (see 14.1.1). The first cycle which is taken into account is the cycle which follows the actual cycle.

The integration time should be an integer number of times the cycle time.

Stop of integration

The last cycle which is taken into account is the cycle when the *Stop* button or any other stop signal appear.

State of integration

The integration can be in 6 different states:

Reset	The energy measurement is stopped, the values are reset to 0
Wait	If the start time is later than the actual time and you have started the integration this state appears until the start time is reached.
Start	This state is displayed from the logical start of integration (e.g. pressing the <i>Start</i> button) until the physical start of integration which is always the begin of the next cycle.
Run	This is displayed while the physical integration is running
Stop	This state is displayed from the logical end of integration (e.g. pressing the <i>Stop</i> button) until the physical end of integration which is always the end of the actual cycle.
Hold	This is displayed if the integration has finished. The integrated values are hold, until the integration continuous (only summing mode) or the values are reset by RESET or <i>Start</i> .

The logical integration is running, if the state is displayed inverse.

5.4.6 Graphical display

With *Graph* you see the graphical display of the normal measuring mode. Also in this menu we have the group concept. With the rotary knob you can select different tabs ('Scope A', 'Scope B', 'Vec.A', 'Vec.B' and 'Extended').

5.4.6.1 Scope A/B

The settings in group A and B are identical, so they are just described once.

Left of this graph you see the Y scaling (ydiv), the Y scaling factor (yzoom) and the four selected signals. Under the graph you see the start position of the graph in seconds, the X

scaling factor (xzoom) and the X scaling (x/div). By pressing the rotary knob you can do the following settings:

Graph Here you can select one of the four scope channels 'A' to 'D'.

Signal Here you can choose the signal to be displayed. The possible values depend on the chosen wiring. In principle you have:

ix: The current of channel x after all activated filters.

ux: The voltage of channel x after all activated filters.

px: The power of channel x after all activated filters.

Which of these values are available depends on the setup on the 'Extended' tab.

zoom By pressing this softkey, you get a small symbol for the rotary knob in the softkey. This means, that from now the rotary knob is used for the zooming. By pressing this softkey several times you can choose if you want to change the x-zoom or y-zoom. You have to confirm your selection with *Enter*.

move By pressing this softkey, you get a small symbol for the rotary knob in the softkey. This means, that from now the rotary knob is used for the moving. By pressing this softkey several times you can choose if you want to change the following setting:

x-pos The signal is moved if you use the rotary knob. So it is possible to see other parts of the wave form.

c1 The first cursor is moved when using the rotary knob. In the second line below the graph you see the X position in seconds and the value of the wave form at this position. The selected cursor position is constant. That means if you scroll the wave form the cursor can move out of the displayed window. If the cursor is outside the visible screen and you move the cursor, it will be set to the border of the visible screen.

c2 Same as c1

c1&c2 Both cursors are moved at the same time. In the second line under the graph you see the time difference and the Y value distance between the two cursors.

Split You can have all graphs in the same screen (good for relations between different signals) or you can have one graph for each signal (good if you have many signals)

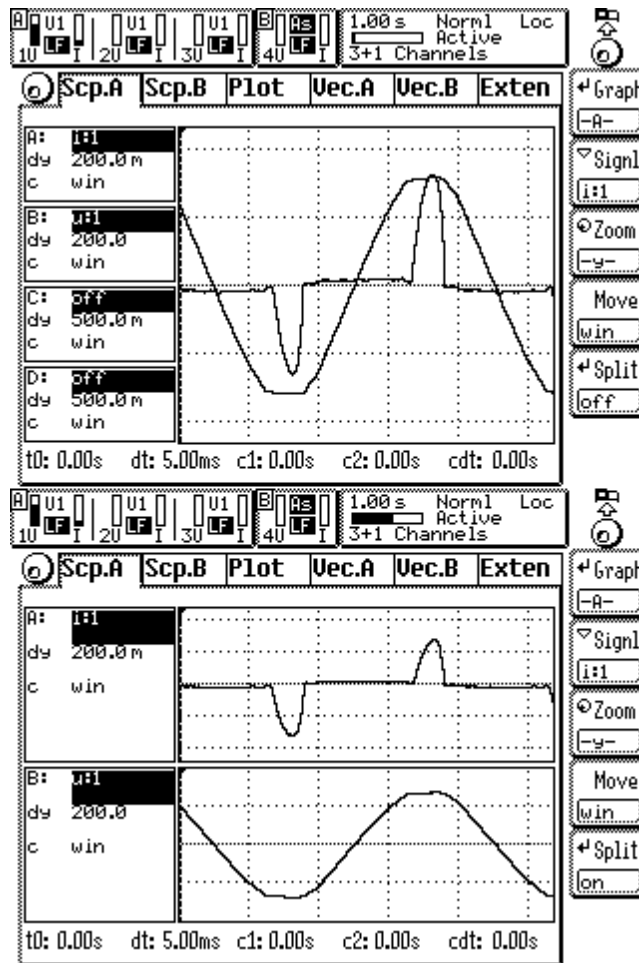

Figure 27: Scope display with split off/on

5.4.6.2 Plot function

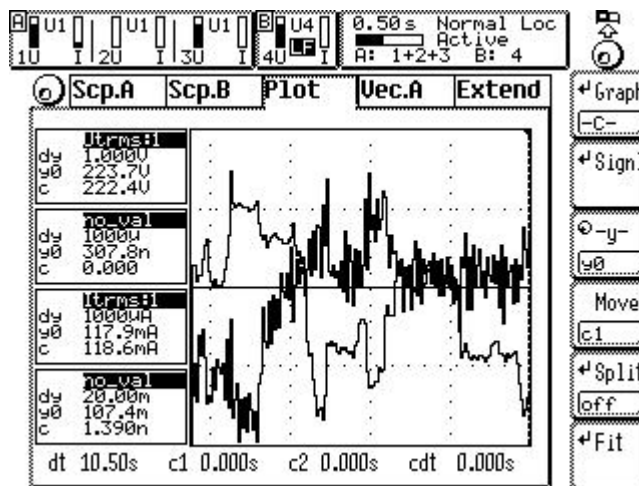

Figure 28: The plot display; split off

In this menu all measured values can be displayed over the time in one or four plots. On the left side, the information segment, the following settings are displayed:

The plotted signal is shown in the colour in which the graph is drawn.

- dy scaling of the y axis per division
- y0 offset of the y axis (value of the centre line)
- c value of the function at the cursor position

Below the graphs the time depending values are displayed:

- dt scaling of the x axis per division
- c1 x value of the first cursor
- c2 x values of the second cursor
- cdt time difference between the cursors

The following settings can be done with the softkeys on the right side:

Chn changes the displayed channel (A-D)

Signl Pressing this softkey a list will open, in which you can adjust the following parameters (refer chapter 4.5):

Signl here you can select the signal to be plot

y/div here you can select the scaling factor of the Y axis

y0 here you can select the offset of the y axis (value of the centre line). Example: If you select $y0 = 200V$ and $y/div = 10V$ the you will see a window from 180V to 220V on the screen.

Each setting is confirmed with *Enter* and rejected with *Esc*.

-y- pressing this softkey - the rotary knob symbol appears in the upper left corner - the adjustments of the y axis can be changed while the plot is running. Each pressing of the button toggles between the parameters dy and y0. The adjusted values can be changed with the rotary knob. The adjustments will be confirmed by pressing the rotary knob or with the *Enter* key.

Move here the cursors are selected. With the rotary knob the cursors will scroll through the plot. For easy reading of the values the plot should be frozen. The scrolling of the cursors can be done for each cursor separately or for both together.

c1 the first cursor is moved. below the graphs the values for the x position in seconds and the value of the function are shown.

c2 same as c1

c1&c2 both cursors are moved at the same time.

Split after pressing this button the display will be split in four separated graphs, refer the following picture:

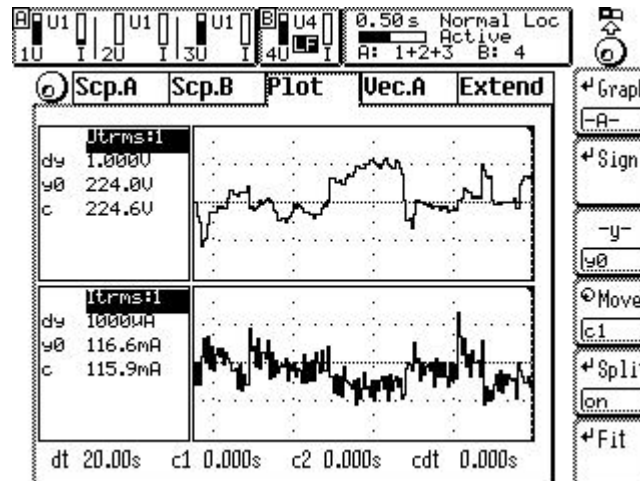

Figure 29: The plot display; split on

Hint: the settings of the cursor are the same for all four to get accurate readings at the selected moment for all channels.

Fit By this the actual selected graph (A to D) is rescaled to fit into the screen.

5.4.6.3 Vec. A/B

The settings in group A and B are identical, so they are just described once.

On this tabs you see the vectors of voltage and current (Fresnel diagramm). In the lower left corner you see the amplitude and the phase angle of the selected signal. In the upper right corner you see the rotating direction of the vectors and the phase counting of the voltages. '1,2,3' means that the zero crossings are in the order 1st, 2nd, 3rd phase. '3,2,1' means that you have the opposite order. By pressing the rotary knob you can do the following settings:

Signal Here you can choose the signal to be displayed. The possible values are voltage or current.

Ref. Here you can choose the reference for the angles:

U U1 is set to 0°

I I1 is set to 0°

None The sync. signal is used as 0° reference.

All angles which are displayed in this menu are relative to this reference angle.

Zoom You can zoom the selected signal to get longer vectors.

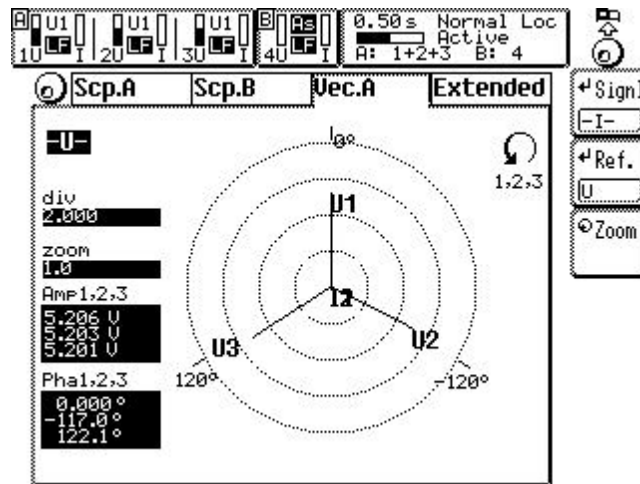

Figure 30: Vector (Fresnel) diagramm

Please note following

1. The angels between the voltages are calculated from the time of the zero crossing in each phase. If you have big distortions on the voltage, this values might be wrong. You can use all possible filter to smooth the voltage.
When using the 'HARM100' measuring mode, this problems will not occur!
2. The angels of the currents are calculated from the power factor. If voltage and current are sinusoidal this value is identical to the $\cos\phi$ and the calculated angels are correct. If you have distortions in the voltage or current signal, this values might be wrong! You can use all possible filters to smooth the voltage and current. Then you can see the phase shift between the fundamentals.
When using the 'HARM100' measuring mode, this problems will not occur!
3. In Aron circuit the calculation of the power factors is in general wrong (this is a disadvantage of this circuit!). So also the current angles are wrong (see above). But you can get valid power factors (and angles) if you use the star to delta conversion (option).

For interface access or other usage inside the instrument please refer to following chapters:

- 10.2.4.1.1.9 Phase angle of current
- 10.2.4.1.1.13 Amplitude of current
- 10.2.4.1.14.9 Phase angle of voltage
- 10.2.4.1.14.13 Amplitude of voltage
- 10.2.10.8.3 Reference setting for angles

5.4.6.4 Extended

Here you can setup which sample values are stored for which time. The duration for recording the sample values depends on several points:

- The available memory. This is displayed in the last line.
- The number of signals to be stored. With the rotary knob you can move to a signal and select it by pressing the softkey.

- **Cycles** allows you to define the minimum duration in times of the cycle time.
- Because of this many influence factors the storing rate and the real duration (both displayed) will vary if you change any of this parameters. In general you can say:
- The bigger the memory (65536 words or 4194304 words) the bigger the record rate. If the full record rate is reached, the duration will increase.
- The fewer signals to be stored, the bigger the record rate. If the full record rate is reached, the duration will increase.
- The shorter the cycle time, the bigger the record rate. If the full record rate is reached, the duration will increase.

If you transfer the sample values to a PC and you want to make evaluations in the frequency domain (e.g. digital filtering or FFT), please make sure that the sampling (record) rate is bigger than twice the bandwidth!

dot The dot joiner connects two following pixels with a line. This function can be set to 'on' or 'off'.

Please note that the grid is always displayed with integer numbers. The cursor positions are calculated from the sample values and have not to fit to the grid.

5.4.7 Custom menu

With *Custom* you see the custom menu. Here you can setup your own menus, calculate formulas and execute programs. See 4.4.3, 'Custom menu' and 4.4.4, 'Script/Formula editor'.

5.5 Storage of values

First you have to change to the menu you want to print out or to store and press *Print/Log* (exact handling see 11, 'Logging of values to drives, printer and interfaces'). All the values you see in this menu are printed out.

6 prCE-Harmonic measuring mode

In the prCE-Harmonic measuring mode the LMG450 works as an high precision harmonic analyser. The number of settings have been reduced to the needed ones to avoid fail handling.

Note!

The synchronisation is fixed to U. For this reason it is important to have a valid signal for synchronisation to get measuring results. **The valid frequency range is from 45 to 65Hz!**

6.1 Measuring configuration (Measuring)

The synchronisation is fixed to the voltage channel. With the rotary knob you can select three tabs ('Globals', 'Group A' and 'Group B').

6.1.1 Global tab

Here the general settings are done.

Eval Selects how the measuring results have to be evaluated:

Class A	The signal is judged according class A of EN61000-3-2:1995 or EN61000-3-2:2006
Class B	The signal is judged according class B of EN61000-3-2:1995 or EN61000-3-2:2006
Class C-1	The signal is judged according class C, Table 1 of EN61000-3-2:1995 or EN61000-3-2:2006
Class C-2	The signal is judged according class C, Table 2 of EN61000-3-2:1995 or EN61000-3-2:2006
Class C-3	The signal is judged according class C, Table 3 of EN61000-3-2:1995 or EN61000-3-2:2006
Class C-W	The signal is judged according class C, special waveform according 7.3 b) of EN61000-3-2:2006
Class D	The signal is judged according class D of EN61000-3-2:1995 or EN61000-3-2:2006
Table 2	The signal is judged according table 2 of EN61000-3-12:2005
Table 3	The signal is judged according table 3 of EN61000-3-12:2005
Table 4	The signal is judged according table 4 of EN61000-3-12:2005

EN... This selects the standard which defines the exact measuring mode of the harmonic analyser:

- 2:95/-4-7:93 The combination EN61000-3-2:1995 and EN61000-4-7:1993 is active
- 2:95/-4-7:08 The combination EN61000-3-2:1995 and EN61000-4-7:2002 is active
- 2:06/-4-7:93 The combination EN61000-3-2:2000 and EN61000-4-7:1993 is active
- 2:06/-4-7:08 The combination EN61000-3-2:2000 and EN61000-4-7:2002 is active
- 12:05/-4-7:08 The combination EN61000-3-12:2005 and EN61000-4-7:2002 is active

System This selects the system which is used for the measurement. There are several possible values:

220V/50Hz, 230V/50Hz, 240V/50Hz

220V/60Hz, 230V/60Hz, 240V/60Hz

120V/50Hz

120V/60Hz

The system is required for example for checking the correct frequency of the measuring setup.

Intv This selects the measuring time for a long time evaluation, for example if you have devices with fluctuation harmonics. The result you can see in the *Int-Value* menu.

Smooth Here you can switch the 1.5s low pass filters for smoothing the fluctuating harmonics on or off. With EN61000-3-2:2006 this point is always on!

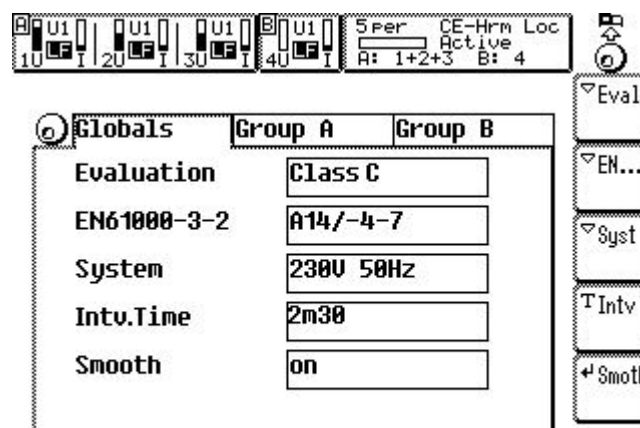

Figure 31: Measuring menu in prCE-Harm mode

6.1.2 Group A/B tab

The settings in group A and B are identical, so they are just described once.

This tab is only accessible if you have chosen EN61000-3-2:2006 with Class C or D or EN61000-3-12:2005!

Here you have to setup the setting which are required for EN61000-3-2:2006. For class C you have to enter the fundamental current and the power factor of your device. For class D you have to enter the active power.

These values are used to calculate the limits. For each value the average measured one is compared to the entered one. If there is a difference of more than 10% all the limits are calculated again with the measured values. In this case it might be, that you have to compare all the measuring results again against the new limits. For this purpose we recommend to use a special test and evaluation software (like for the SYS61K system).

Class C

With **PF** and **Curr** you can enter the power factor and the fundamental current.

Class D

With **Pow** you can enter the active power.

EN61000-3-12

With **R_{sce}** you enter the R_{sce} value of the system.

6.2 Measuring ranges (Range)

The settings are the same like in 5.2, 'Measuring ranges (Range)'. Please note that the standards require a continuous measuring without gaps. For that reason the auto range function should be deactivated to prevent a range change, because this will cause a short measurement with invalid values.

6.3 Definition of measuring values

The following basic definitions are used:

n The harmonic order.

T The time of an integer number of the periods of the synchronisation signal

Voltage and current

true root mean square:
$$U_{trms} = \sqrt{\frac{1}{T} \int_{t=0}^T u(t)^2 dt} \quad I_{trms} = \sqrt{\frac{1}{T} \int_{t=0}^T i(t)^2 dt}$$

DC component:	$U_{dc} = \frac{1}{T} \int_{t=0}^T u(t) dt$	$I_{dc} = \frac{1}{T} \int_{t=0}^T i(t) dt$
AC component:	$U_{ac} = \sqrt{U_{trms}^2 - U_{dc}^2}$	$I_{ac} = \sqrt{I_{trms}^2 - I_{dc}^2}$
crest factor:	$U_{cf} = \frac{U_{pk}}{U_{trms}}$	$I_{cf} = \frac{I_{pk}}{I_{trms}}$
total harmonic distortion:	$U_{thd} = \sqrt{\sum_{n=2}^{40} \left(\frac{U_n}{U_1} \right)^2}$	$I_{thd} = \sqrt{\sum_{n=2}^{40} \left(\frac{I_n}{I_1} \right)^2}$

The harmonic values 'I(n)' and 'U(n)' are calculated by using a DFT algorithm. The limit values 'Limit (n)' are calculated according to IEC61000-3-2.

Power

active power:
$$P = \left(\frac{1}{T} \int_{t=0}^T u(t)i(t) dt \right) - U(0) * I(0)$$

with EN61000-4-7:2002/A1:2009

$$P = \frac{1}{T} \int_{t=0}^T u(t)i(t) dt$$

in all other cases

reactive power:
$$Q = \sqrt{S^2 - P^2}$$

apparent power:
$$S = U_{trms} * I_{trms}$$

power factor:
$$\lambda = \frac{|P|}{S}$$

Impedances

apparent impedance:
$$Z = \frac{U_{trms}}{I_{trms}}$$

active impedance:
$$R_{ser} = \frac{P}{I_{trms}^2}$$

reactive impedance:
$$X_{ser} = \frac{Q}{I_{trms}^2}$$

6.4 Display of values

For the display of the values we have the same rules like in the normal measuring mode (see 5.4, 'Display of values').

6.4.1 Default

With *Default* you see the most important values of the instrument. For the handling please see the general description in chapter 5.4, 'Display of values'.

6.4.2 Voltage

With *Voltage* you see the harmonic values of the measured voltage and in the second row the allowed limits in this voltage (if you see a single channel). A '!' between the two rows shows that the measuring value is bigger than the limit. In this menu you see always the evaluation of the actual measured window!

With the arrow keys or with the shuttle knob you can scroll through the list to see all harmonics.

In the top line you see the total trms value of the signal and the frequency of the synchronisation source.

Below the softkeys you see the result of the complete voltage judgement: a '✓' indicates that all requirements of the standard are met. A '✗' indicates a fault measuring result. This result is only the result of the actual measuring and not influenced by earlier measurements.

Voltage A		Voltage B	
Uthd	3.32 %	Norm	Class A
Utrms	224.17 V	f	50.004 Hz
Chn.4		Limit	
0	0.04 U	-----	
1	223.22 U	-----	
2	0.09 U	0.45 U	
3	3.02 U!	2.02 U	
4	0.04 U	0.45 U	
5	5.91 U?	0.90 U	
6	0.03 U	0.45 U	
7	3.06 U?	0.67 U	
8	0.02 U	0.45 U	
9	0.79 U!	0.45 U	✗

Figure 32: Display of voltages in prCE-Harm mode

6.4.3 Current

With *Current* you see the harmonic values of the measured current and in the second row the allowed limits in this current. A '!' between the two rows shows that the measuring value is bigger than the limit. A '?' between the two rows shows that the measuring value is bigger than 100%, but smaller than 150% of the limit (which is important for fluctuating harmonics!). This special evaluation is only valid for the harmonics of order 2, 3, 4, 5, 6, 7, 8, 9, 10, 11, 13, 15, 17 and 19. The '?' indicates that the harmonic might be outside the standard if the '?' appears for more than 10% of a any 2.5min windows.

If the current is $<5\text{mA}$ or $<0.6\%$ of I_{trms} there is no judgement of the current. For this reason '-----' is displayed for the limit.

With the arrow keys or with the shuttle knob you can scroll through the list to see all harmonics.

In the top line you see the total trms value of the signal and the frequency of the synchronisation source.

Below the softkeys you see the result of the complete current judgement: a '✓' indicates that all requirements of the standard are met. A '✘' indicates a fault measuring result. This result is only the result of the actual measuring and not influenced by earlier measurements.

Please note:

If only '?' appear and no '!' then the result will be '✓', because this is only the short term result, which might be correct.

6.4.4 Power

With *Power* you see the most important power values of the instrument. For the handling please see the general description in chapter 5.4, 'Display of values'

6.4.5 Long time evaluation

In this menu you see the result of the long time evaluation. This is started with *Start* and can be cancelled with the *Stop* button. You see in the first row the order of the harmonics, followed by the maximum measured current.

The third row shows the evaluation for fluctuating harmonics. According to the standard it is allowed that some defined harmonics have values up to 1.5 times the limit for maximum 10% of a 2.5 minute window. The maximum percentage out of this window is displayed here. If the value is bigger than 10% you have a '!' behind this value.

In the fourth row you see if the current harmonics have violated any point of the standard anytime while the complete long time measuring. If you have here a '!' the device under test does not fulfil the standard!

In the last row you see if the test voltage has ever violated the harmonic limits.

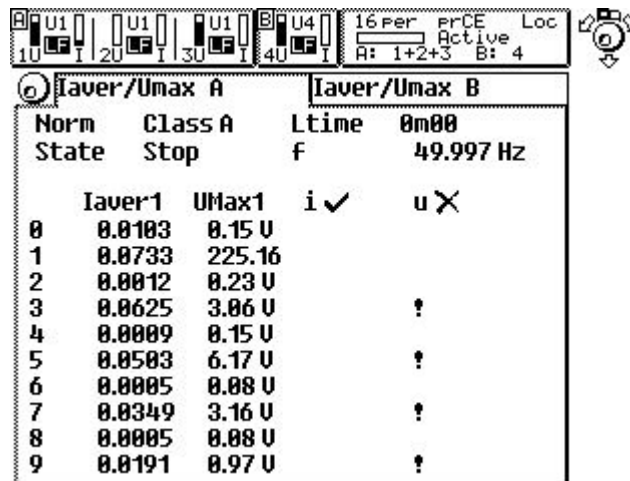

Figure 33: Long time evaluation of harmonics

Below the softkeys you see the total evaluation of the measurement. If any current harmonic has violated the standard at any time or the differences between control and measured values of power (class D) or of current and power factor (class C) were more than 10% (only for A14) you have 'Test I ✗'. If any voltage harmonic or the amplitude or the frequency have violated the standard you have 'Test U ✗'. The printing and logging of this menu is only possible in single mode (see 4.4.2.1, 'Interfaces for remote control') and with ASCII format.

6.4.6 Graphical display

With *Graph* you see the graphical display of the prCE measuring mode. Also in this menu we have the group concept. With the rotary knob you can select different tabs ('Spectrum A' and 'Spectrum B').

6.4.6.1 Spectrum A/B

The settings in group A and B are identical, so they are just described once.

The graphical display of the voltage, the current and the limits of the harmonics. On the left side you see for each graph signal value (yn), the limit value (yl) at cursor position, the scaling of the y-axis (dy) and the zoom of the y-axis (zm).

If you have logarithmic display, the dy value specifies the signal level at the top line. The lower lines have each a tenth of the upper ones.

Graph Here you can select one of the four possible display channels.

Signl Defines the signal for this display channel. Possible values are (for each channel):

- U The voltage harmonics
- LU The limits of the voltage harmonics and the voltage harmonics
- I The current harmonics
- LI The limits of the current harmonics and the current harmonics

For the displays with limits and harmonics you have always one thin bar with the limit, one thin bar with the measuring value and again one thin bar with the limit. So the value is covered by the limits.

You can imagine that the limits are displayed like a cup filled with water (which represents the values). If you have too much in the cup you have a problem.

Zoom Allows you to zoom the signals in y direction

Move Allows you to move the cursor to another position.

Split You can have one graph in one big screen or you can have several graphs in several screens (see pictures below)

Log changes between linear scaling (=off) and logarithmic scaling (=on) for the y-axis.

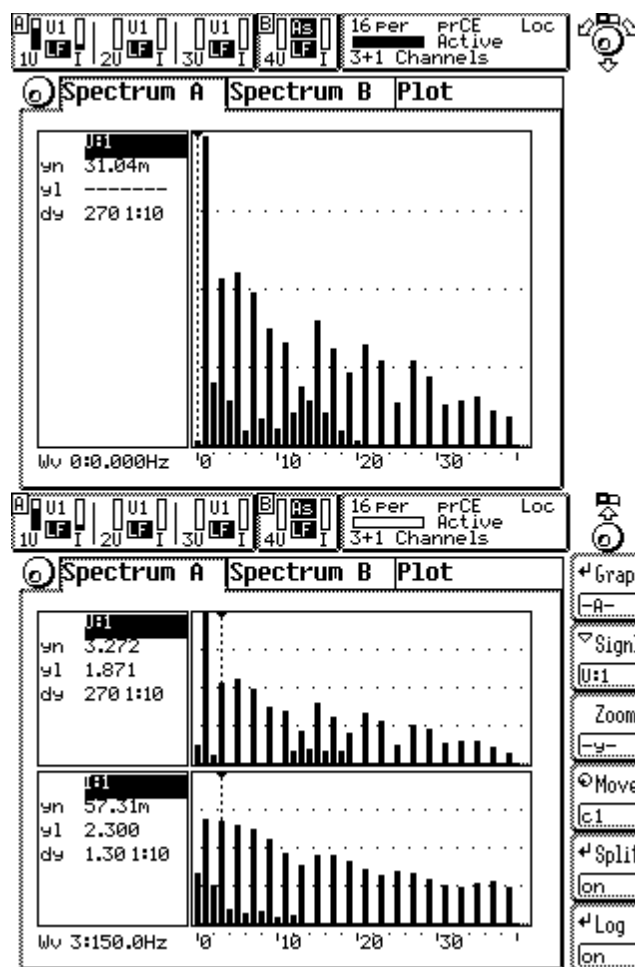

Figure 34: Graphical display of harmonics

6.4.6.2 Plot function

For the plot function we have the same rules like in the normal measuring mode (see '5.4.6.2, Plot function')

6.4.7 Custom menu

With *Custom* you see the custom menu. Here you can setup your own menus, calculate formulas and execute programs. See 4.4.3, 'Custom menu' and 4.4.4, 'Script/Formula editor'.

6.5 Storage of values

First you have to change to the menu you want to print out or to store and press *Print/Log* (exact handling see 11, 'Logging of values to drives, printer and interfaces'). All the values you see in this menu are printed out. In the menus with harmonic values you get all harmonics (not only the ones you see!).

6.6 Precompliance tests according EN61000-3-2

For tests according to this standard you first have to change the *Range* to 'Manual' mode. This is necessary because the test has to be done without any gaps.

Now you go to the *Measuring* menu, change the version with **EN** to '61000-3-2:1995' or '61000-3-2:2006' and select with **Eval** the class you want to test.

Now you can switch on the voltage. When the LMG is synchronised you can switch on the equipment under test (EUT).

If you want to make long time evaluations you can start them with *Start*.

7 CE-Flicker measuring mode (option L45-O4)

In the CE-Flicker measuring mode the LMG450 works as an high precision flicker analyser according to IEC61000-4-15. The number of settings has been reduced to the needed ones to avoid fail handling.

Note!

In this measuring mode the valid frequency range is from **45 to 65Hz!**

7.1 Measuring configuration (Measuring)

The synchronisation is fixed to the voltage channel. With the rotary knob you can only select 'Globals' tab.

7.1.1 Globals tab

Here the general settings are done.

dMax This selects the dmax limit for the measuring. This value has to be taken out of the standard, depending on the measuring requirements.

EN Defines the standard which should be used:

3:95/-4-15	EN61000-3-3:1995 with EN61000-4-15:1998/A1:2003
3:08/-4-15	EN61000-3-3:2008 with EN61000-4-15:1998/A1:2003
3:08B2/-4-15	EN61000-3-3:2008 with EN61000-4-15:1998/A1:2003 This one is especially for tests according annex B.2
-11:2000	EN61000-3-11:2000 with EN61000-4-15:1998/A1:2003

Syst This selects the system which is used for the measurement. There are four possible values:

230V/50Hz
230V/60Hz
120V/50Hz
120V/60Hz

The system is required for example for checking the correct frequency of the measuring setup.

Intv This is the interval time of the short term flicker measuring. The standard value is 10min.

Per. This is the number of short term periods for the long term measurement. The standard value is 12 periods for a long term time of 2 hours.

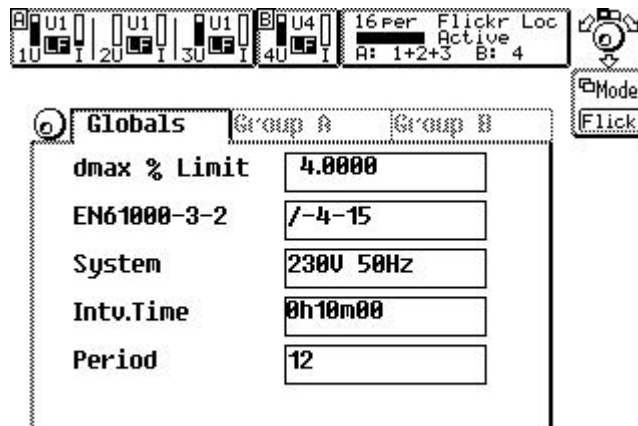

Figure 35: Measuring menu in CE-Flicker mode

7.1.2 Ztest/Zref tab

This is only available when EN61000-3-11 is selected.

With **Ztest** you have to enter your actual used test impedance in Ω .

With **Zref** you have to choose, if your reference impedance is $(0.24+j0.15)\Omega$ or $(0.4+j0.25)\Omega$.

The values for d_c , d_{max} , P_{st} and P_{lt} are recalculated as described in EN61000-3-11:2000

7.2 Measuring ranges (Range)

The settings are the same like in '5.2, Measuring ranges (Range)'. Please note that the standards require a continuous measuring without gaps. For that reason the auto range function should be deactivated to prevent a range change, because this will cause a short measurement with invalid values.

7.3 Definition of measuring values

The following basic definitions are used:

n The harmonic order.

T The time of an integer number of the periods of the synchronisation signal. The integer factor depends on the standard IEC61000-4-7. Actually 16 periods are measured.

Voltage and current

true root mean square:
$$U_{trms} = \sqrt{\frac{1}{T} \int_{t=0}^T u(t)^2 dt} \qquad I_{trms} = \sqrt{\frac{1}{T} \int_{t=0}^T i(t)^2 dt}$$

total harmonic distortion:
$$U_{thd} = \sqrt{\sum_{n=2}^{40} \left(\frac{U_n}{U_1} \right)^2} \qquad I_{thd} = \sqrt{\sum_{n=2}^{40} \left(\frac{I_n}{I_1} \right)^2}$$

The harmonic values 'I(n)' and 'U(n)' are calculated by using a DFT algorithm.

The values 'Pmom', 'Pst' and 'Plt' are calculated using a flickermeter according to EN61000-4-15. 'dc' and 'dmax' are calculated according to EN61000-3-3.

Power

active power:
$$P = \frac{1}{T} \int_{t=0}^T u(t)i(t)dt$$

reactive power:
$$Q = \sqrt{S^2 - P^2}$$

apparent power:
$$S = U_{trms} * I_{trms}$$

power factor:
$$\lambda = \frac{|P|}{S}$$

Impedances

apparent impedance:
$$Z = \frac{U_{trms}}{I_{trms}}$$

active impedance:
$$R_{ser} = \frac{P}{I_{trms}^2}$$

reactive impedance:
$$X_{ser} = \frac{Q}{I_{trms}^2}$$

7.4 Display of values

For the display of the values you can choose several menus.

7.4.1 Default

For the display of the values we have the same rules like in the normal measuring mode (see 5.4, 'Display of values')

7.4.2 Voltage

Here you see the TRMS value, the THD and the frequency.

7.4.3 Current

Here you see the TRMS value, the THD and the frequency.

7.4.4 Power

For the display of the values we have the same rules like in the normal measuring mode (see 5.4, 'Display of values')

7.4.5 Flicker (Int. Val)

In this menu you see the flicker values of the equipment under test (EUT). You see the short term flicker level P_{st} , the long term flicker level P_{lt} , the actual flicker level P_{mom} , the relative steady-state voltage change d_c , the maximum relative voltage change d_{max} , the remaining long term time, the remaining short term time and the state of the flicker measuring.

The state can be 'starting' (8s from pressing *START*), 'running' (while the long term interval) and 'stooped' after the measuring.

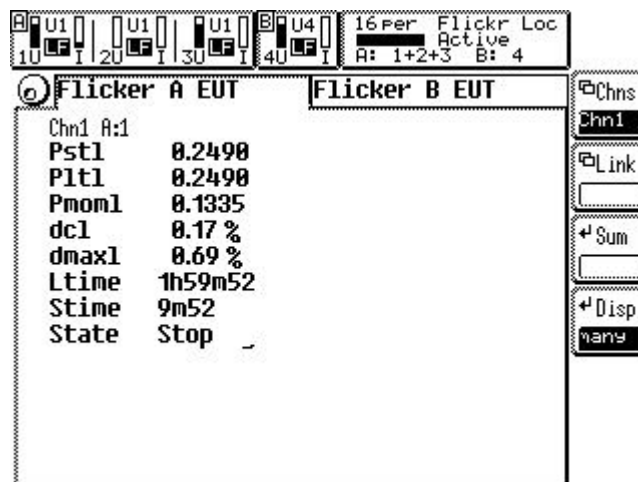

Figure 36: Evaluation of flicker measurement

d_{max} is measured over the long term time.

d_c is the relative voltage change between two 'constant' voltages. Therefore it can have different values:

$d_c = \text{-----}$ means that there was no constant voltage.

$d_c = 0.000\%$ means that there was exactly one constant voltage.

Any other value is the biggest difference between two constant voltages.

P_{It} is calculated at the end of the long term measuring. Until then it is displayed as '-----'.

7.4.6 Graphical display

Here just the plot function is available. The handling is the same like described in 5.4.6, 'Graphical display'

But there are some things to know concerning the displayed values:

In the other modes, all values are measured in the same time interval. In the flicker mode there are two main time intervals: 10ms and 320ms. Most values are updated every 320ms, but some come every 10ms: They are the momentary flicker level (ID is Pml) and the half wave trms value (ID is Uhw1). As said above, this values come every 10ms. The Pmom1 and Utrms values are the average values of Pml and Uhw1. So you can see Pmom1 and Pml in one graph as function 'A' and 'B'. Because Pmom1 has a slower time base, it is plotted with 32 same values.

7.4.7 Custom menu

With *Custom* you see the custom menu. Here you can setup your own menus, calculate formulas and execute programs. See 4.4.3, 'Custom menu' and 4.4.4, 'Script/Formula editor'.

7.5 Storage of values

First you have to change to the menu you want to print out or to store and press *Print/Log* (exact handling see 11, 'Logging of values to drives, printer and interfaces'). All the values you see in this menu are printed out.

7.6 Tests according EN61000-3-3

For tests according to this standard you first have to change the *Range* to 'Manual' mode. This is necessary because the test has to be done without any gaps.

Switch on the voltage of the EUT. Start the flicker process with *Start*. After a delay of 8s the real measuring is started. Now you can switch on the EUT to get the different values. If you want to stop the measuring before the end of the long term time just press *Stop*.

Annex B.2

Usually the values d_c and d_{max} run for the whole observation period (Plt-time). To simplify tests according annex B.2 of EN61000-3-3:2008, you can choose, that these values are reset after each short term observation periode. To do this, please select the B2 item in measuring menu, softkey **EN**.

8 100 Harmonics measuring mode (option L45-O8)

In the 100 Harmonics measuring mode the LMG450 works as a high precision harmonic analyser. The difference to the prCE mode is, that 100 harmonics, the phase angles and the power harmonics are measured. The frequency range is much wider. There is no check against any limits.

8.1 Measuring configuration (Measuring)

When you came to this menu by pressing *Measure* you first have to choose **MODE** and then **HARM** to enter this mode. The well known setting menu with the three tabs („Globals“, „Group A“ and „Group B“) opens:

Globals Here you can set up the wiring in which is measured.

Group A/B For the settings in this menu refer 5.1.2 Group A/B tab. One additional setting is possible:

FDiv This defines a frequency divider for the basic wave. With a value of 1 the measured frequency is identical to the basic wave. With a value of 2 the fundamental has only the half frequency of the measured frequency (e.g. A 50Hz signal with **FDiv** = 4 is analysed on a 12.5Hz base. So you get 3 interharmonic between the 50Hz Harmonics)

Only with **FDIV** set to 1 you get the THD values of the signals

Pressing the rotary knob you will get to the main menu.

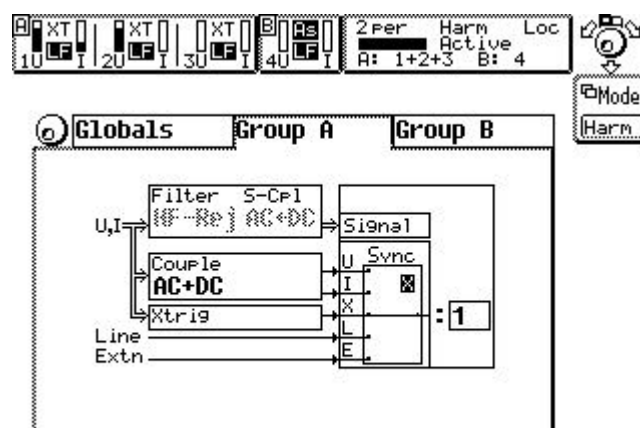

Figure 37: Measuring menu in Harm100 mode

8.2 Measuring ranges (Range)

The settings are the same like in 5.2 ‘Measuring ranges (Range)’, but in this mode you have no autorange function.

8.3 Definition of measuring values

The following basic definitions are used:

n The harmonic order.

T The time of an integer number of the periods of the synchronisation signal. The integer factor depends on the frequency of the basic wave:

Basic wave range / Hz	Number of measured periods	Sample frequency divider	Automatically selected filter
640-1280	16	1	HF-Rejection
320-640	8	1	HF-Rejection
160-320	4	1	HF-Rejection
80-160	2	1	18kHz
40-80	2	2	6kHz
20-40	2	4	2.8kHz
10-20	2	8	1.4kHz
5-10	2	16	700Hz
2.5-5	2	32	350Hz
1.25-2.5	2	64	175Hz
0.625-1.25	2	128	87.5Hz

The ‘sample frequency divider’ defines, how the sampling frequency of about 50kHz is divided for this measuring.

Voltage and current

true root mean square:
$$U_{rms} = \sqrt{\frac{1}{T} \int_{t=0}^T u(t)^2 dt} \quad I_{rms} = \sqrt{\frac{1}{T} \int_{t=0}^T i(t)^2 dt}$$

total harmonic distortion:
$$U_{thd} = \sqrt{\sum_{n=2}^{99} \left(\frac{U_n}{U_1} \right)^2} \quad I_{thd} = \sqrt{\sum_{n=2}^{99} \left(\frac{I_n}{I_1} \right)^2}$$

Only with **FDIV** set to 1 you get the THD values of the signals.

The harmonic components are calculated to meet the following:

$$u(t) = \sum_{n=0}^{99} \sqrt{2} U_n \sin(n\omega t + \varphi_{un}) \quad i(t) = \sum_{n=0}^{99} \sqrt{2} I_n \sin(n\omega t + \varphi_{in})$$

The harmonic values 'I(n)', 'U(n)' and 'Phase(n)' are calculated by using a DFT algorithm. With this values also the values of 'P(n)', 'S(n)' and 'Q(n)' are calculated. This 'Q(n)' is only the reactive power, caused by a phase shift of a voltage and current component with the same frequency. Therefore it is in this mode possible to calculate also the reactive power which is caused by voltage and current components with different frequencies. This value is called D:

$$D = \sqrt{S^2 - P^2 - Q_{shift}^2} \quad \text{with } Q_{shift} = \sum_{n=0}^{99} Q(n), \text{ P and S see below.}$$

Power

active power:
$$P = \frac{1}{T} \int_{t=0}^T u(t)i(t)dt$$

reactive power:
$$Q = \sqrt{S^2 - P^2}$$

apparent power:
$$S = U_{rms} * I_{rms}$$

power factor:
$$\lambda = \frac{|P|}{S}$$

Impedances

apparent impedance:
$$Z = \frac{U_{rms}}{I_{rms}}$$

active impedance:
$$R_{ser} = \frac{P}{I_{rms}^2}$$

reactive impedance:
$$X_{ser} = \frac{Q}{I_{rms}^2}$$

8.4 Display of values

For the display of the values you can choose several menus.

Harmonic values (amplitude, phase, frequency, ...) can just be displayed constant in steady state condition due to the nature of FFT. While signal changes (frequency and/or amplitude) you will get unexpected signals (they are not wrong, but due to the special calculation method 'FFT' they might look different than you expect).

The influence of the HF-Rejection filter is compensated for the amplitudes of the harmonics. The values for U, I and P are not recalculated from the harmonics, but are calculated from the sampling values to get for example interharmonics and components with higher frequencies which are not captured by the harmonics. So it is not possible to compensate the influence of

the filters for this values! For the same reason this values can also be much bigger than the values which can be derived from the harmonics (depending on the signal).

8.4.1 Default

With *Default* you see the most important values of the instrument. The available settings are described in „5.4 Display of values“.

8.4.2 Voltage

With *Voltage* you see the harmonic values of the measured voltage and in the second row the phase of the harmonic component.

With the softkey **Chns** you can choose the channel.

With the softkey **Href** you can select the reference signal (voltage, current or none). The fundamental of this signal is always set to 0°. When selected ‘none’, the time window is the reference.

With the softkey **Link** the harmonics of the linked values will be shown.

Using the rotary knob you can scroll through the list to see all harmonics.

8.4.3 Current

With *Current* you see the harmonic values of the measured current and in the second row the phase of the harmonic component.

With the softkey **Chns** you can choose the channel.

With the softkey **Href** you can select the reference signal (voltage, current or none). The fundamental of this signal is always set to 0°. When selected ‘none’, the time window is the reference.

With the softkey **Link** the harmonics of the linked values will be shown.

Using the rotary knob you can scroll through the list to see all harmonics.

8.4.4 Power

With *Power* you see the harmonic values of the measured powers. The synchronisation frequency is shown in the first row, displaying all channels.

With the softkey **Chns** you can choose the channel.

With **List** you can choose several lists with the different combinations of the different powers.

Using the rotary knob you can scroll through the list to see all harmonics.

Please note

The harmonics of the power are not the results of a fourier transformation of the power waveform, but are calculated by same frequent voltage and current harmonics.

8.4.5 Graphical display

Here just the plot function, the spectrum and the vector diagram is available. The handling is the same like described in 5.4.6, 'Graphical display' and 6.4.6.1, 'Spectrum A/B'.

8.4.6 Custom menu

With *Custom* you see the custom menu. Here you can setup your own menus, calculate formulas and execute programs. See 4.4.3, 'Custom menu' and 4.4.4, 'Script/Formula editor'.

8.5 Storage of values

First you have to change to the menu you want to print out or to store and press *Print/Log* (exact handling see 11, 'Logging of values to drives, printer and interfaces'). All the values you see in this menu are printed out. In the menus with harmonic values you get all harmonics (not only the ones you see!).

9 Transient mode (option L45-O5)

In the transient measuring mode the LMG450 works as a transient recorder. You can define special events. If they occur the measuring is stopped and you can analyse the signal.

9.1 Measuring configuration (Measuring)

When you came to this menu by pressing *Measure* you first have to choose **MODE** and then **TRANS** to enter this mode. The well known setting menu with the three tabs („Globals“, „Group A“ and „Group B“) opens:

9.1.1 Globals tab

Here you can set up the wiring in which is measured and general conditions which are equal for all groups.

By pressing the rotary knob, you can setup the following values:

- TDur** This is the minimum duration of the event. If you for example set this value to 5ms and check for an over limit, the signal has to be over the limit for 5ms until the event is generated.
- TRec** This is the recording time. The signal is recorded for this time to the memory. If you have more memory, it might be recorded for a longer time.
Please note: If your memory is too small and/or you want to record too much signals the recording rate might be reduced. This has no influence on the sampling rate or on the event detection.
- PreTr** This is the pretrigger duration in %. If you for example have a record time of 200ms and 50% pretrigger you will get at minimum 100ms before the event and exact 100ms after the event.
- Wire** Here you can setup, with which wiring you want to measure. Please see chapter 2.4, 'The group concept' for further details.
If a linked wiring is used, only the linked channels can generate a trigger event.

9.1.2 GroupA/B tab

The settings in all groups are identical, so they are just described once!

General

- The settings of a group are valid for all channels of the group.
- The channels of a group are OR combined. If at least one channel is triggered, the complete group is triggered.
- The groups are also OR combined. If one group is triggered, the other one is also triggered.

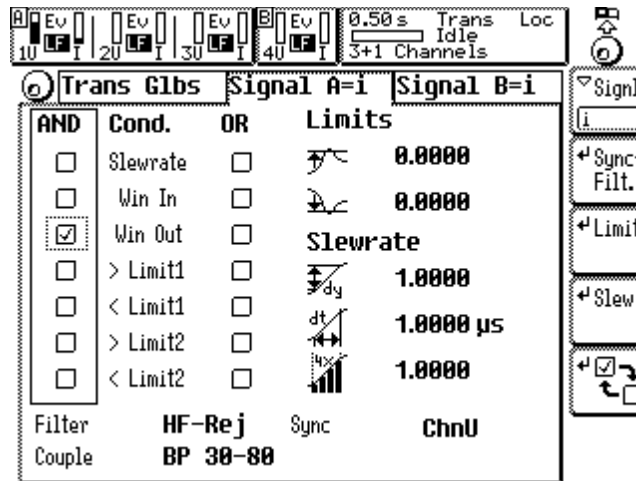

Figure 38 Measuring menu in transient mode

Signl This defines which signal should be watched for the transient event. Following settings are possible: i, u, p.

Sync+Filt Here you reach a sub-menu in which you can setup some values:

Sync Selects the signal which is used for synchronisation. There are four possible settings:

- ChnU The voltage signal is used
- ChnI The current signal is used
- Line The line signal is used
- Extn The signal at the external synchronisation jack is used.

Coupl Selects how the voltage or current signal is coupled to the following trigger stage. This setting has **no** influence to the measured signals! Please refer to 5.1.2, ‘Group A/B tab’.

Filt Here you can select if the filters in the signal path of voltage and current are active or not. This filters are only in the signal way and don’t influence the synchronisation. For the possible settings see 5.1.2, ‘Group A/B tab’

You have to leave this menu by pressing *Enter* or *ESC*. The settings for **Coupl** and **Sync** you did in this menu are not used for the transient search itself but for continuously measuring the TRMS and peak values of voltage and current. This values are used to update the over and under range display in the status line.

Limit Here you can setup the limits for the events. The instantaneous value of the signal to be watched is checked against the limit if it is bigger (or smaller) an event is generated. If a function needs two limits (e.g. Win In) **Lim1** is the upper limit and **Lim2** the lower limit.

Slewr Here you can setup the maximum allowed slewrate of the signal. For this you have 3 possible settings:

dSig This is the required signal change in the time interval **dt**.

dt This is the time interval.

overx This is the width of the slewrate watch window in number of sample values.

For example you have a signal with a typical rise time of 3.5V in 450 μ s. In this case you have to enter 3.5 with **dSig** and 450 μ with **dt**. Herewith you have defined the steep of the signal: 7.777V/ms or 7.777mV/ μ s. With a sample interval of about 20 μ s (20 μ s *7.777mV/ μ s = 155.54mV) this is only about 3 bit (in 600V range; 1 bit = 1600Vpeak/32768 = 48.8mV) of the converter resolution. That means, if the difference between two sample values is bigger than 3 bit you would get an event. But from several sources you have a small noise on the signal. This would cause fail events. To prevent this you can use the parameter **overx**. With it you can define, that the slewrate is not defined over one sample period but over up to 15. If you for example choose 15 (15*20 μ s*7.777mV/ μ s=2.333V), the signal has to change 48 bit in this example! So you can use **overx** to suppress noise effects.

While you are in the **Set** mode you can use the rotary knob to define the trigger condition. Move to the desired position and press *Enter* to mark/unmark the condition. In the left column you can setup the AND condition. Only if all of this marked events happen at the same time the result of the AND condition will be true. In the right column you can setup the OR condition. If one or more of the marked events happen or the result of the AND condition is true you will get an event.

An event is generated depending on the event type if:

Slewr the slew rate of the signal is bigger than defined by the **Slewr** menu.

Win In the signal is <Limit1 and >Limit2

Win Out the signal is >Limit1 or <Limit2

>Limit1 the signal is >Limit1

<Limit1 the signal is <Limit1

>Limit2 the signal is >Limit2

<Limit2 the signal is <Limit2

If you enter the transient mode the instrument is always in the 'Idle' state (see status line). To start a transient search press *Start*. In the status line changes to 'Start'. This state lasts until the pretrigger time is over. While this time no events are detected. Now the status changes to 'Search'. Now an event would be detected. To end a search press the *Stop* key. In this case an event is simulated and you can check if for example your trigger time definitions are okay. Pressing the *Stop* key is same like generating an event. The instrument changes to 'PostTr' state to record the posttrigger values. If this has finished, the last status will be 'Finish'. Now you can watch the values and start a new search.

If you are searching a transient, you see the record time in the status line. The bar below blinks.

9.2 Measuring ranges (Range)

The settings are the same like in 5.2, 'Measuring ranges (Range)'. Only manual range is possible.

9.3 Display of values

For the display of the values you can choose only one menu.

9.3.1 Graphical display

The settings are the same like in 5.4.6, 'Graphical display', but there is only the scope function in the transient mode.

The second exception is the **Min.Div.** softkey on the 'Extended' tab. It is similar to the **Cycls** softkey in the normal mode (see 5.4.6.4, 'Extended'). By it you can define, that the sample rate should be divided at least by this number. So you can get a longer time duration onto one screen of the scope.

9.4 Storage of values

First you have to change to the menu you want to print out or to store and press *Print/Log* (exact handling see 11, 'Logging of values to drives, printer and interfaces'). All the values you see in this menu are printed out.

10 Interfaces (IEEE option L45-O1)

With exception of the IEEE interface all interfaces could also be used for data logging (see 11, 'Logging of values to drives, printer and interfaces'). To remote control the LMG please reserve first the wished interface for this job (see 4.4.2.1, 'Interfaces for remote control').

This chapter includes all commands and a short general syntax description. A much more detailed syntax description with a lot of examples and further programming explanations can be found in our *Programmer's Guide* on the CD which is included in the printed version of this manual. If this is missing or you have just a PDF version of this manual you can request the *Programmer's Guide* by email from 'sales@zes.com'.

10.1 Short syntax description

There are two implemented languages: SCPI and SHORT. When switching on the instrument SCPI is selected. To change to SHORT you have to send:

```
SYST:LANG SHORT
```

For further differences between SCPI and SHORT command set see also 10.2.4, ':FETCh and :READ commands'

The general syntax for both command sets is identical. The most important syntax rules are:

- A message to the instrument has to be terminated with an EOS character.
- brackets [...] are showing optional part of commands. There is no need to send them to the device, but you can do it, if you need this function. The brackets are just informative and should not be sent.
- The number of the measuring channel (further on called 'suffix') follows directly (without any space) after the identifier. If you don't specify one, '1' is assumed.
- If you request a value you have to add a '?' directly behind the suffix (or the identifier, if no suffix is specified), without any space.
- All parameters following the commands have to be separated from the command with at least one space character.
- The group number is usually an optional parameter in the format [, <NRi>]. If you don't specify it, group A (=0) is assumed as default value.
- '/qonly/' indicates, that this is a value which can only be demanded, but not set. Do not send the '/qonly/' string to the device, it is just written in this manual to explain the command. For example you can't send a measuring value.

- ‘/nquery/’ indicates that this value can only be set, and not demanded. Do not send the ‘/nquery/’ string to the device, it is just written in this manual to explain the command. For example you can’t request a trigger command.
- All commands without ‘/qonly/’ and ‘/nquery/’ can be read and set.
- <NRf> are float numbers
- <NRi> are integer numbers
- <list> stands for <(<NRf>:<NRf>)>. With this construct you can request several values which are stored in an array, for example harmonic values. To get the 3rd to 11th harmonic of the voltage of the second measuring channel you have to write in SHORT command set: HUAM2? (3:11)

For the complete syntax rules please take a look at the *Programmer’s Guide!*

Examples showing the syntax

Equivalent SCPI commands for reading the TRMS value of the 1st measuring channel:

```
:FETCh:CURRent:TRMS?
:FETC:CURR:TRMS?
:FETC:CURR:TRMS1?
```

As SHORT command it would be

```
ITRMS? or ITRMS1?
```

Please note that there is no space before the ‘1’ and no space before the ‘?’!

Command for reading the harmonic voltages from the 2nd to the 4th harmonic (3 values):

```
:FETC:HARM:VOLT:AMPL? (2:4)
```

Please notice that there is at least one space between the question mark and the parameters!

Command for setting the 250V range:

```
:SENS:VOLT:RANG 250
```

Please notice that there is at least one space before the parameter 250!

Command for setting the 250V range in the 3rd channel:

```
:SENS:VOLT:RANG3 250
```

Please notice that there is no space before the suffix and at least one space before the 250!

Commands for setting and reading a filter in group B (short language):

```
FILT 5,1
FILT? 1
```

For group A you can write:

```
FILT 5,0 or FILT 5
FILT? 0 or FILT?
```

For more examples please take a look at the *Programmer’s Guide!*

10.2 Commands

Here you find all commands the instrument can handle. The commands are ordered like in the SCPI tree structure. The description is always the same:

SCPI: *The SCPI syntax of the command*
 SHORT: *The SHORT syntax of the command*

ID:	<i>The ID for script editor and similar</i>	Mode:	<i>The valid measuring modes</i>
Type:	<i>The data type</i>	Suffix:	<i>The valid suffix range</i>
Value:	<i>The value range</i>	List:	<i>The valid list range</i>
Unit:	<i>The physical unit</i>	Group:	<i>The valid group range</i>

An 'n/a' means 'not applicable'. If you for example see an 'n/a' in the 'Value:' field, then this command has no value at all. Or it is a float number with all valid codes according IEEE754.

The titles of the useable commands are in a box. There you find from left to right: SCPI command, SHORT command and the ID if existing.

Please see also 10.1, 'Short syntax description'.

For all this commands there is a separated index. See chapter 17, 'Interface command index'.

10.2.1 IEEE488.2 common commands

This are commands which are defined in IEEE488.2, but they are pure ASCII commands and can also be sent via other interfaces like RS232.

10.2.1.1 *CLS	*CLS
----------------------	-------------

SCPI: *CLS/nquery/
 SHORT: *CLS/nquery/

ID:	n/a	Mode:	all
Type:	n/a	Suffix:	n/a
Value:	n/a	List:	n/a
Unit:	n/a	Group:	n/a

Clears the event registers of all status data structures in a device and the error/event queue.

10.2.1.2 *ESE	*ESE
----------------------	-------------

SCPI: *ESE <NRi>
 SHORT: *ESE <NRi>

ID:	n/a	Mode:	n/a
Type:	long int	Suffix:	n/a
Value:	0...255	List:	n/a
Unit:	n/a	Group:	n/a

Used to set up or read out the Event Status Enable Register.

10.2.1.3 *ESR?***ESR?**

SCPI: *ESR? /qonly/
SHORT: *ESR? /qonly/

ID:	n/a	Mode:	all
Type:	long int	Suffix:	n/a
Value:	0...255	List:	n/a
Unit:	n/a	Group:	n/a

Reads out and clears the Event Status Register.

10.2.1.4 *IDN?***IDN?**

SCPI: *IDN? /qonly/
SHORT: *IDN? /qonly/

ID:	n/a	Mode:	all
Type:	n/a	Suffix:	n/a
Value:	n/a	List:	n/a
Unit:	n/a	Group:	n/a

Reads out the identification of the device. There are 4 fields separated by commas:

Field 1 Manufacturer

Field 2 Model

Field 3 Serial number

Field 4 Firmware level

10.2.1.5 *IST?***IST?**

SCPI: *IST? /qonly/
SHORT: *IST? /qonly/

ID:	n/a	Mode:	all
Type:	long int	Suffix:	n/a
Value:	0, 1	List:	n/a
Unit:	n/a	Group:	n/a

Individual Status Query. This returns the status of the 'ist' local message in the device.

10.2.1.6 *OPC***OPC**

SCPI: *OPC/nquery/
SHORT: *OPC/nquery/

ID:	n/a	Mode:	all
Type:	n/a	Suffix:	n/a
Value:	n/a	List:	n/a
Unit:	n/a	Group:	n/a

Causes the device to set the operation complete bit in the Standard Event Status Register, when all pending selected device operations have been finished.

10.2.1.7 *OPC?	*OPC?
-----------------------	--------------

SCPI: *OPC? /qonly/
SHORT: *OPC?/qonly/

ID: n/a	Mode: all
Type: char	Suffix: n/a
Value: '1'	List: n/a
Unit: n/a	Group: n/a

Causes the device to place a „1“ (=31h) in the output queue, when all pending selected device actions have been finished (=operation complete). This is independent from the output format!

10.2.1.8 *PRE	*PRE
----------------------	-------------

SCPI: *PRE <NRi>
SHORT: *PRE <NRi>

ID: n/a	Mode: all
Type: long int	Suffix: n/a
Value: 0...65535	List: n/a
Unit: n/a	Group: n/a

Used to set up or read out the Parallel Poll Enable Register

10.2.1.9 *RST	*RST
----------------------	-------------

SCPI: *RST/nquery/
SHORT: *RST/nquery/

ID: n/a	Mode: all
Type: n/a	Suffix: n/a
Value: n/a	List: n/a
Unit: n/a	Group: n/a

This performs a device reset. A lot of internal settings (like measuring mode, ranges, ...) are set to their default values. In this chapters the default value is indicated by '[*RST Default value]'. All time dependent measurements are stopped (energy, flicker, harmonics).

The interface and it's parameters are not reset! If you want to reset it, please use a BREAK with RS232 interface or a 'device clear' with IEEE interface.

Hint

The execution of this command can take up to several seconds. The LMG works internally with a watchdog protection. To prevent that the watchdog becomes active, the '*RST'

command should be send as the only command in a message. Just the ‘*OPC?’ can be added to get a feedback, if the command has finished (‘*RST;*OPC?’). In this case wait until the ‘1’ returns before sending the next commands!

10.2.1.10 *SRE	*SRE
-----------------------	-------------

SCPI: *SRE <NRi>
SHORT: *SRE <NRi>

ID: n/a	Mode: all
Type: long int	Suffix: n/a
Value: 0...255	List: n/a
Unit: n/a	Group: n/a

Sets or queries the Service Request Enable Register

10.2.1.11 *STB?	*STB?
------------------------	--------------

SCPI: *STB? /qonly/
SHORT: *STB? /qonly/

ID: n/a	Mode: all
Type: long int	Suffix: n/a
Value: 0...255	List: n/a
Unit: n/a	Group: n/a

Queries the Status Byte Register.

10.2.1.12 *TRG	*TRG
-----------------------	-------------

SCPI: *TRG/nquery/
SHORT: *TRG/nquery/

ID: n/a	Mode: all
Type: n/a	Suffix: n/a
Value: n/a	List: n/a
Unit: n/a	Group: n/a

Triggers the same action that happens when programmer sends DT1 via IEEE488.1 interface or ‘&TRG<cr><lf>’ via RS232 interface. Actually nothing is performed.

10.2.1.13 *TST?	*TST?
------------------------	--------------

SCPI: *TST? /qonly/ <NRi>
SHORT: *TST?/qonly/ <NRi>

ID: n/a	Mode: all
Type: long int	Suffix: n/a
Value: n/a	List: n/a
Unit: n/a	Group: n/a

Initiates a self test. Returns a value depending on <NRi>. This command should only be used by ZES and not by customers.

10.2.1.14 *WAI *WAI

SCPI: *WAI/nquery/
SHORT: *WAI/nquery/

ID:	n/a	Mode:	all
Type:	n/a	Suffix:	n/a
Value:	n/a	List:	n/a
Unit:	n/a	Group:	n/a

Waits until all pending selected device operations have been finished. Note: The instrument handles commands in a queue, so when executing the *WAI all previous commands have been executed. Thus the instrument is doing nothing when receiving the *WAI command. It has been implemented to follow the standard IEEE488.2.

10.2.2 :CALCulate commands

Here you find commands which influence the script editor (formulas) or limits.

:CALCulate	→	:ENVironment
:DISPlay		:FORMula
:FETCh		:LIMit
:FORMat		
:INITiate		
:INPut		
:INSTrument		
:MEMory		
:READ		
:SENSe		
:SOURce		
:STATus		
:SYSTem		
:TRIGger		

10.2.2.1 ENVironment ENV Env

SCPI: :CALCulate:ENVironment <NRf>[,<NRi>]
SHORT: ENV <NRf>[,<NRi>]

ID:	Env	Mode:	all
Type:	float	Suffix:	n/a
Value:	n/a	List:	n/a
Unit:	n/a	Group:	optional [,<NRi>]: 0=Env0, ... ,7=Env7

Sets or queries an environment variable.

10.2.2.2 :FORMula

:CALCulate	→	:ENVironment
:DISPlay		:FORMula → [:DEFine]
:FETCh		:LIMit

```

:FORMat
:INITiate
:INPUt
:INSTrument
:MEMory
:READ
:SENSe
:SOURce
:STATus
:SYSTem
:TRIGger
    
```

10.2.2.2.1 [:DEFine] FORM

SCPI: :CALCulate:FORMula[:DEFine] <string program data>
 SHORT: FORM<string program data>

ID:	n/a	Mode:	all
Type:	string	Suffix:	n/a
Value:	n/a	List:	n/a
Unit:	n/a	Group:	n/a

Sets or reads the script of the script editor. There is no *RST default value.

For example ‘FORM „a=1;“<lf>‘ sets the internal variable a to 1.

10.2.2.3 :LIMit:

```

:CALCulate → :ENVironment
:DISPlay   :FORMula
:FETCh     :LIMit → :CLASs
:FORMat    :DMax
:INITiate  :FCURrent
:INPUt     :PFACtor
:INSTrument :POWer
:MEMory    :SYSTem
:READ      :VERSion
:SENSe
:SOURce
:STATus
:SYSTem
:TRIGger
    
```

10.2.2.3.1 :CLASs EVAL

SCPI: :CALCulate:LIMit:CLASs <NRi>
 SHORT: EVAL <NRi>

ID:	n/a	Mode:	prCE
Type:	long int	Suffix:	n/a
Value:	0...6, 10...12	List:	n/a
Unit:	n/a	Group:	n/a

Sets the evaluation of the harmonics in the prCE mode:

- 0: Class A (EN61000-3-2) [*RST default value]
- 1: Class B (EN61000-3-2)
- 2: Class C-2 (EN61000-3-2)

- 3: Class D (EN61000-3-2)
- 4: Class C-3 (EN61000-3-2)
- 5: Class C-W (EN61000-3-2)
- 6: Class C-1 (EN61000-3-2)
- 10: Table 2 (EN61000-3-12)
- 11: Table 3 (EN61000-3-12)
- 12: Table 4 (EN61000-3-12)

10.2.2.3.2 :DMAX	FLDL
-------------------------	-------------

SCPI: :CALCulate:LIMit:DMAX <NRf>
 SHORT: FLDL <NRf>

ID: n/a	Mode: Flicker
Type: float	Suffix: n/a
Value: in %	List: n/a
Unit: n/a	Group: n/a

Sets the allowed limit for d_{\max} for the device under test according to the standard in the flicker mode.

10.2.2.3.3 :FCURrent	ISO
-----------------------------	------------

SCPI: :CALCulate:LIMit:FCURrent <NRf>
 SHORT: ISO <NRf>

ID: n/a	Mode: prCE
Type: float	Suffix: 1...4
Value: n/a, [*RST default value] = 1.0	List: n/a
Unit: A	Group: n/a

Sets or reads the fundamental current for the EN61000-3-2:2006 limit calculation in the CE mode.

10.2.2.3.4 :FVERsion	FNRM
-----------------------------	-------------

SCPI: :CALCulate:LIMit:FVERsion <NRi>
 SHORT: FNRM <NRi>

ID: n/a	Mode: Flicker
Type: long int	Suffix: n/a
Value: 0...3	List: n/a
Unit: n/a	Group: n/a

Sets or reads the edition of the flicker standard:

- 0: EN61000-3-3:1995 [*RST default value]
- 1: EN61000-3-3:2008
- 2: EN61000-3-3:2008 Annex B.2
- 3: EN61000-3-11:2000

10.2.2.3.5 :PFACTOR	PFSO
----------------------------	-------------

SCPI: :CALCulate:LIMit:PFACTOR <NRf>
 SHORT: PFSO <NRf>

ID: n/a	Mode: prCE
Type: float	Suffix: 1...4
Value: n/a, [*RST default value] = 1.0	List: n/a
Unit: n/a	Group: n/a

Sets or reads the power factor for the EN61000-3-2:2006 limit calculation in the CE mode.

10.2.2.3.6 :POWER	PSO
--------------------------	------------

SCPI: :CALCulate:LIMit:POWER <NRf>
 SHORT: PSO <NRf>

ID: n/a	Mode: prCE
Type: float	Suffix: 1...4
Value: n/a, [*RST default value] = 1.0	List: n/a
Unit: W	Group: n/a

Sets or reads the power for the EN61000-3-2:2006 limit calculation in the CE mode.

10.2.2.3.7 :RSCE	RSCE
-------------------------	-------------

SCPI: :CALCulate:LIMit:RSCE <NRf>
 SHORT: RSCE <NRf>

ID: n/a	Mode: prCE
Type: float	Suffix: n/a
Value: 33...10000, [*RST default value] = 33	List: n/a
Unit: n/a	Group: n/a

Sets or reads the R_{sce} for the EN61000-3-12:2005 limit calculation in the prCE mode.

10.2.2.3.8 :SYSTEM	SYSD
---------------------------	-------------

SCPI: :CALCulate:LIMit:SYSTEM <NRi>
 SHORT: SYSD <NRi>

ID: n/a	Mode: prCE
Type: long int	Suffix: n/a
Value: 0...3	List: n/a
Unit: n/a	Group: n/a

Sets or reads the supply system for the CE harmonics and flicker:

0: 230V/50Hz [*RST default value]

1: 230V/60Hz

2: 120V/50Hz

3: 120V/60Hz

4: 220V/50Hz

5: 220V/60Hz

6: 240V/50Hz

7: 240V/60Hz

10.2.2.3.9 :VERSion**EDIT**SCPI: :CALCulate:LIMit:VERSion <NRi>
SHORT: EDIT <NRi>

ID:	n/a	Mode:	prCE
Type:	long int	Suffix:	n/a
Value:	0...4	List:	n/a
Unit:	n/a	Group:	n/a

Sets or reads the edition of the harmonic standard:

0: EN61000-3-2:1995 and EN61000-4-7:1993 [*RST default value]

1: EN61000-3-2:1995 and EN61000-4-7:2008

2: EN61000-3-2:2006 and EN61000-4-7:1993

3: EN61000-3-2:2006 and EN61000-4-7:2008

4: EN61000-3-12:2005 and EN61000-4-7:2008

10.2.2.3.10 :ZREF**ZREF**SCPI: :CALCulate:LIMit:ZREF <NRf>
SHORT: ZREF <NRf>

ID:	n/a	Mode:	Flicker
Type:	int	Suffix:	n/a
Value:	0, 1	List:	n/a
Unit:	n/a	Group:	n/a

Sets or reads the Z_{ref} for the EN61000-3-11:2000 limit calculation.0: $(0.24+j0.15)\Omega$ [*RST default value]1: $(0.40+j0.25)\Omega$ **10.2.2.3.11 :ZTEST****ZTST**SCPI: :CALCulate:LIMit:ZTEST <NRf>
SHORT: ZTST <NRf>

ID:	n/a	Mode:	Flicker
Type:	float	Suffix:	n/a
Value:	0.001...2, [*RST default value] = 0.283	List:	n/a
Unit:	Ω	Group:	n/a

Sets or reads the Z_{test} for the EN61000-3-11:2000 limit calculation.

10.2.3 :DISPlay commands

```

:CALCulate
:DISPlay → :CONTrast
:FETCh      :RESet
:FORMat
:INITiate
:INPut
:INSTrument
:MEMory
:READ
:SENSe
:SOURce
:STATus
:SYSTem
:TRIGger

```

10.2.3.1 :CONTrast

DISC

SCPI: :DISPlay:CONTrast <NRf>
 SHORT: DISC <NRf>

ID:	n/a	Mode:	all
Type:	float	Suffix:	n/a
Value:	0...100 in %, [*RST default value] = 65	List:	n/a
Unit:	n/a	Group:	n/a

Sets or reads the contrast of the display.

10.2.3.2 :RESet

DISR

SCPI: :DISPlay:RESet
 SHORT: DISR

ID:	n/a	Mode:	all
Type:	n/a	Suffix:	n/a
Value:	n/a	List:	n/a
Unit:	n/a	Group:	n/a

Resets the display to the default values. (e.g. small fonts...).

10.2.4 :FETCh and :READ commands

These both commands are used to get measuring values from the instrument. With :FETCh you get the values which are actually in the copied buffer for the interface. With :READ there are internally two commands executed: :INITiate:IMMEDIATE and :FETCh (see also 10.2.6.3, ‘:IMMEDIATE INIM’ for further details).

If you request the same value twice with two :READ commands (e.g.

:READ:DC?;:READ:DC?) you get two different values of two different cycles. This can cause problems for example with following request:

```
:READ:VOLTAGE:DC?;:READ:CURRENT:DC?
```

The two values you get for Udc and Idc are measured in different cycles!

If you request the same value twice with two :FETCh commands you get the same values of the same cycle. For example :FETC:DC?;:FETC:DC? would not make any sense, because you will get the same value.

A usual request looks like this:

```
:READ:VOLTAGE:DC?;:FETC:CURRENT:DC?
```

In this case the instrument finishes the actual cycle, copies the values for the interface and returns the two requested values. This two values are measured in the same cycle!

The SHORT commands perform equal to the :FETCh commands (which means there is no INIM performed!). So if you want to perform the last example with SHORT commands you have to enter INIM;UDC?;IDC?

10.2.4.1 [:SCALar]

10.2.4.1.1 :CURRent

:CALCulate			
:DISPlay			
:FETCh →	[:SCALar] →	:CURRent →	:AC
:FORMat		:CYCLe	:CFACtor
:INITiate		:DINPut	:DC
:INPut		:ENERgy	:FFACtor
:INSTrument		:FLICKer	:INRush
:MEMory		:FREQuency	:MAXPk
:READ →		:HARMonics	:MINPk
:SENSe		:POWer	:PPEak
:SOURce		:RESistance	:RECTify
:STATus		:SSYStem	:RUSed
:SYSTem		:VARiable	[:TRMS]
:TRIGger		[:VOLTage]	

10.2.4.1.1.1 :AC? IAC? lac

SCPI: :FETCh[:SCALar]:CURRent:AC? /qonly/ | :READ[:SCALar]:CURRent:AC? /qonly/
SHORT: IAC? /qonly/

ID:	lac	Mode:	Normal, prCE
Type:	float	Suffix:	1...12
Value:	n/a	List:	n/a
Unit:	A	Group:	n/a

Reads the AC value of the current.

10.2.4.1.1.2 :CFACtor? ICF? lcf

SCPI: :FETCh[:SCALar]:CURRent:CFACtor? /qonly/ | :READ[:SCALar]:CURRent:CFACtor? /qonly/
SHORT: ICF?/qonly/

ID:	lcf	Mode:	Normal
-----	-----	-------	--------

Type:	float	Suffix:	1...12
Value:	n/a	List:	n/a
Unit:	n/a	Group:	n/a

Reads the crest factor of the current.

10.2.4.1.1.3 :DC?	IDC?	Idc
--------------------------	-------------	------------

SCPI: :FETCh[:SCALar]:CURRent:DC? /qonly/ | :READ[:SCALar]:CURRent:DC? /qonly/
 SHORT: IDC? /qonly/

ID:	Idc	Mode:	Normal, prCE
Type:	float	Suffix:	1...12
Value:	n/a	List:	n/a
Unit:	A	Group:	n/a

Reads the DC value of the current.

10.2.4.1.1.4 :FFACtor?	IFF?	Iff
-------------------------------	-------------	------------

SCPI: :FETCh[:SCALar]:CURRent:FFACtor? /qonly/ | :READ[:SCALar]:CURRent:FFACtor? /qonly/
 SHORT: IFF? /qonly/

ID:	Iff	Mode:	Normal
Type:	float	Suffix:	1...12
Value:	n/a	List:	n/a
Unit:	n/a	Group:	n/a

Reads the form factor of the current.

10.2.4.1.1.5 :FSCale?	FSI?
------------------------------	-------------

SCPI: :FETCh[:SCALar]:CURRent:FSCale? /qonly/ | :READ[:SCALar]:CURRent:FSCale? /qonly/
 SHORT: FSI? /qonly/

ID:	n/a	Mode:	All
Type:	float	Suffix:	1...12
Value:	n/a	List:	n/a
Unit:	A	Group:	n/a

Reads the full scale value of the current.

10.2.4.1.1.6 :INRush?	IINR?	linr
------------------------------	--------------	-------------

SCPI: :FETCh[:SCALar]:CURRent:INRush? /qonly/ | :READ[:SCALar]:CURRent:INRush? /qonly/
 SHORT: IINR? /qonly/

ID:	linr	Mode:	Normal
Type:	float	Suffix:	1...12
Value:	n/a	List:	n/a
Unit:	A	Group:	n/a

Reads the value of the inrush current. For reset see 10.2.14.2

10.2.4.1.1.7 :MAXPk?	IMAX?	lpkp
-----------------------------	--------------	-------------

SCPI: :FETCh[:SCALar]:CURRent:MAXPk? /qonly/ | :READ[:SCALar]:CURRent:MAXPk? /qonly/
 SHORT: IMAX? /qonly/

ID: lpkp	Mode: Normal
Type: float	Suffix: 1...12
Value: n/a	List: n/a
Unit: A	Group: n/a

Reads the biggest sample value of the current.

10.2.4.1.1.8 :MINPk?	IMIN?	lpkn
-----------------------------	--------------	-------------

SCPI: :FETCh[:SCALar]:CURRent:MINPk? /qonly/ | :READ[:SCALar]:CURRent:MINPk? /qonly/
 SHORT: IMIN? /qonly/

ID: lpkn	Mode: Normal
Type: float	Suffix: 1...12
Value: n/a	List: n/a
Unit: A	Group: n/a

Reads the smallest sample value of the current.

10.2.4.1.1.9 :PHASe?	IPHI?	lphi
-----------------------------	--------------	-------------

SCPI: :FETCh[:SCALar]:CURRent:PHASe? /qonly/ | :READ[:SCALar]:CURRent:MINPk? /qonly/
 SHORT: IPHI? /qonly/

ID: n/a	Mode: Normal
Type: float	Suffix: 1...4
Value: n/a	List: n/a
Unit: °	Group: n/a

Reads the phase angle of the current like displayed in the Fresnel diagram.

10.2.4.1.1.10 :PPEak?	IPP?	lpp
------------------------------	-------------	------------

SCPI: :FETCh[:SCALar]:CURRent:PPEak? /qonly/ | :READ[:SCALar]:CURRent:PPEak? /qonly/
 SHORT: IPP? /qonly/

ID: lpp	Mode: Normal
Type: float	Suffix: 1...12
Value: n/a	List: n/a
Unit: A	Group: n/a

Reads the peak peak value of the current.

10.2.4.1.1.11 :RECTify?	IREC?	irect
--------------------------------	--------------	--------------

SCPI: :FETCh[:SCALar]:CURRent:RECTify? /qonly/ | :READ[:SCALar]:CURRent:RECTify? /qonly/
 SHORT: IREC? /qonly/

ID:	Irect	Mode:	Normal
Type:	float	Suffix:	1...12
Value:	n/a	List:	n/a
Unit:	A	Group:	n/a

Reads the rectified value of the current.

10.2.4.1.1.12 :RUSed?	OVRI?	Ovrl
------------------------------	--------------	-------------

SCPI: :FETCh[:SCALar]:CURRent:RUSed? /qonly/ | :READ[:SCALar]:CURRent:RUSed? /qonly/
 SHORT: OVRI? /qonly/

ID:	Ovrl	Mode:	All
Type:	float	Suffix:	1...12
Value:	0...100 in %	List:	n/a
Unit:	n/a	Group:	n/a

Reads the usage of the current range.

10.2.4.1.1.13 [:TRMS?]	ITRMS?	Itrms
-------------------------------	---------------	--------------

SCPI: :FETCh[:SCALar]:CURRent[:TRMS]? /qonly/ | :READ[:SCALar]:CURRent[:TRMS]? /qonly/
 SHORT: ITRMS? /qonly/

ID:	Itrms	Mode:	All
Type:	float	Suffix:	1...14
Value:	n/a	List:	n/a
Unit:	A	Group:	n/a

Reads the TRMS value of the current.

10.2.4.1.2 :CYCLE

```

:CALCulate
:DISPlay
:FETCh →      [:SCALar] →      :CURRent
:FORMat          :CYCLE →      :COUNT
:INITiate          :DINPut      :TIME
:INPut            :ENERgy
:INSTrument       :FLICKer
:MEMory           :FREQuency
:READ →          :HARMonics
:SENSe           :POWER
:SOURce          :RESistance
:STATus          :SSYSstem
:SYSTem          :VARiable
:TRIGger         [:VOLTage]
    
```

10.2.4.1.2.1 :COUNT?	COUNT?	Cnr
-----------------------------	---------------	------------

SCPI: :FETCh[:SCALar]:CYCLE:COUNT? /qonly/ | :READ[:SCALar]:CYCLE:COUNT? /qonly/
 SHORT: COUNT? /qonly/

ID:	Cnr	Mode:	All
Type:	float	Suffix:	n/a

Value: 0...65535 List: n/a
Unit: n/a Group: n/a

Reads an individual number of the measuring cycle counter which is copied into memory. This value runs up to 65535 and starts then again at 0.

10.2.4.1.2.2 :SNUMber? SCTC?

SCPI: :FETCh[:SCALar]:CYCLe:SNUMber? /qonly/ | :READ[:SCALar]:CYCLe:SNUMber? /qonly/
SHORT: SCTC? /qonly/

ID: n/a Mode: All
Type: long int Suffix: n/a
Value: 0...2³¹-1 List: n/a
Unit: n/a Group: n/a

Reads the number of the last sample value of a cycle. The sample values of the instrument are counted. At the end of each cycle this counter is stored and can be read by this command. The counter runs up to 2³¹-1 and starts then again at 0. See also 10.2.10.14.5, ‘:SCTRigger? SCTT?’

10.2.4.1.2.3 :TIME? CYCR? Mtime

SCPI: :FETCh[:SCALar]:CYCLe:TIME? /qonly/ | :READ[:SCALar]:CYCLe:TIME? /qonly/
SHORT: CYCR? /qonly/

ID: Mtime Mode: Normal, prCE, Flicker, HARM100
Type: float Suffix: 1...14
Value: n/a List: n/a
Unit: s Group: n/a

Reads the real measuring time of the measuring cycle. This is the time for an integer number of periods of the measured signal (in average this is the cycle time, but it depends on the signal!).

10.2.4.1.3 :DINPut? DIST?

SCPI: :FETCh[:SCALar]:DINPut? /qonly/ | :READ[:SCALar]:DINPut? /qonly/
SHORT: DIST? /qonly/

ID: digin(), see 4.4.4.2.7, ‘Functions’ Mode: All
Type: long int Suffix: 1,2
Value: 0...64 List: n/a
Unit: n/a Group: n/a

Reads the status of the digital inputs. The bits in the answer have following meanings:

- Bit 0: Input 1
- Bit 1: Input 2
- Bit 2: Input 3
- Bit 3: Input 4

Bit 4: Input 5

Bit 5: Input 6

10.2.4.1.4 :ENERgy

:CALCulate			
:DISPlay			
:FETCh →	[:SCALar] →	:CURRent	
:FORMat		:CYCLe	
:INITiate		:DINPut	
:INPut		:ENERgy →	[:ACTive]
:INSTrument		:FLICKer	:APParent
:MEMory		:FREQuency	:CHARge
:READ →		:HARMonics	:REACTive
:SENSe		:POWer	:TIME
:SOURce		:RESistance	
:STATus		:SSYStem	
:SYSTem		:VARiable	
:TRIGger		[:VOLTage]	

10.2.4.1.4.1 [:ACTive]?	EP?	EP
--------------------------------	------------	-----------

SCPI: :FETCh[:SCALar]:ENERgy[:ACTive]? /qonly/ | :READ[:SCALar]:ENERgy[:ACTive]? /qonly/
 SHORT: EP? /qonly/

ID:	EP	Mode:	Normal
Type:	float	Suffix:	1...14
Value:	n/a	List:	n/a
Unit:	Wh	Group:	n/a

Reads the active energy (integrated active power).

10.2.4.1.4.2 :APParent?	ES?	ES
--------------------------------	------------	-----------

SCPI: :FETCh[:SCALar]:ENERgy:APParent? /qonly/ | :READ[:SCALar]:ENERgy:APParent? /qonly/
 SHORT: ES? /qonly/

ID:	ES	Mode:	Normal
Type:	float	Suffix:	1...14
Value:	n/a	List:	n/a
Unit:	VAh	Group:	n/a

Reads the apparent energy (integrated apparent power).

10.2.4.1.4.3 :CHARge?	EI?	q
------------------------------	------------	----------

SCPI: :FETCh[:SCALar]:ENERgy:CHARge? /qonly/ | :READ[:SCALar]:ENERgy:CHARge? /qonly/
 SHORT: EI? /qonly/

ID:	q	Mode:	Normal
Type:	float	Suffix:	1...14
Value:	n/a	List:	n/a
Unit:	Ah	Group:	n/a

Reads the charge (integrated DC current).

10.2.4.1.4.4 :REACTIVE?	EQ?	EQ
--------------------------------	------------	-----------

SCPI: :FETCh[:SCALAr]:ENERgy:REACTIVE? /qonly/ |
:READ[:SCALAr]:ENERgy:REACTIVE? /qonly/
SHORT: EQ? /qonly/

ID: EQ	Mode: Normal
Type: float	Suffix: 1...14
Value: n/a	List: n/a
Unit: varh	Group: n/a

Reads the reactive energy (integrated reactive power).

10.2.4.1.4.5 :TIME?	INTR?	
----------------------------	--------------	--

SCPI: :FETCh[:SCALAr]:ENERgy:TIME? /qonly/ | :READ[:SCALAr]:ENERgy:TIME? /qonly/
SHORT: INTR? /qonly/

ID: LoadOK	Mode: Normal
Type: long int	Suffix: 1...14
Value: 0...2 ³¹ -1	List: n/a
Unit: ms	Group: n/a

Reads the time of the running integration.

10.2.4.1.5 :FLICKer

10.2.4.1.5.1 [:EUTest]

Selects the equipment under test measuring results. They are measured at the voltage input jacks.

:CALCulate			
:DISPlay			
:FETCh →	[:SCALAr] →	:CURRent	
:FORMat		:CYCLe	
:INITiate		:DINPut	
:INPut		:ENERgy	
:INSTrument		:FLICKer →	[:EUTest] →
:MEMory		:FREQuency	:LTRemain
:READ →		:HARMonics	:PHWave
:SENSe		:POWer	:SOURce
:SOURce		:RESistance	:STATe
:STATus		:SSYStem	:STRemain
:SYSTem		:VARiable	:PLT
:TRIGger		[:VOLTage]	:PMOMentary
			:PST
			:RESult

10.2.4.1.5.1.1 :APMoment?	FLMO?	Pmoml
----------------------------------	--------------	--------------

SCPI: :FETCh[:SCALAr]:FLICKer[:EUTest]:APMoment? /qonly/ |
:READ[:SCALAr]:FLICKer[:EUTest]:APMoment? /qonly/

SHORT: FLMO? /qonly/

ID:	Pmoml	Mode:	Flicker
Type:	float	Suffix:	1...4
Value:	n/a	List:	n/a
Unit:	n/a	Group:	n/a

Reads the averaged momentary flicker level of the equipment under test. It is averaged over 16 periods.

10.2.4.1.5.1.2	:DC?	FLDC?	dcl
-----------------------	-------------	--------------	------------

SCPI: :FETCh[:SCALar]:FLICker[:EUTest]:DC? /qonly/ |
:READ[:SCALar]:FLICker[:EUTest]:DC? /qonly/
SHORT: FLDC? /qonly/

ID:	dcl	Mode:	Flicker
Type:	float	Suffix:	1...4
Value:	in %	List:	n/a
Unit:	n/a	Group:	n/a

Reads the d_c value of the equipment under test.

10.2.4.1.5.1.3	:DELTat?	FLDT?	dtl
-----------------------	-----------------	--------------	------------

SCPI: :FETCh[:SCALar]:FLICker[:EUTest]:DELTat? /qonly/ <list> |
:READ[:SCALar]:FLICker[:EUTest]:DELTat? /qonly/ <list>
SHORT: FLDT? /qonly/ <list>

ID:	dtl	Mode:	Flicker
Type:	float	Suffix:	1...4
Value:	in %	List:	0...31
Unit:	n/a	Group:	n/a

Reads the $d(t)$ values of the equipment under test. After each measuring cycle over 16 periods you can get 32 values.

10.2.4.1.5.1.4	:DMAX?	FLDX?	dmaxl
-----------------------	---------------	--------------	--------------

SCPI: :FETCh[:SCALar]:FLICker[:EUTest]:DMAX? /qonly/ |
:READ[:SCALar]:FLICker[:EUTest]:DMAX? /qonly/
SHORT: FLDX? /qonly/

ID:	dmaxl	Mode:	Flicker
Type:	float	Suffix:	1...4
Value:	in %	List:	n/a
Unit:	n/a	Group:	n/a

Reads the d_{max} value of the equipment under test.

10.2.4.1.5.1.5 :DTMViolation? FLMV?

SCPI: :FETCh[:SCALar]:FLICker[:EUTest]:DTMViolation? /qonly/ |
 :READ[:SCALar]:FLICker[:EUTest]:DTMViolation? /qonly/
 SHORT: FLMV? /qonly/

ID:	n/a	Mode:	Flicker
Type:	long int	Suffix:	1...4
Value:	n/a	List:	n/a
Unit:	n/a	Group:	n/a

Reads the maximum number of half waves for which the d(t) of the equipment under test was bigger than allowed in the standard.

10.2.4.1.5.1.6 :HWTRms? FLRM? UhwI

SCPI: :FETCh[:SCALar]:FLICker[:EUTest]:HWTRms? /qonly/ <list> |
 :READ[:SCALar]:FLICker[:EUTest]:HWTRms? /qonly/ <list>
 SHORT: FLRM? /qonly/ <list>

ID:	UhwI	Mode:	Flicker
Type:	float	Suffix:	1...4
Value:	n/a	List:	0...31
Unit:	V	Group:	n/a

Reads the half wave TRMS values of the equipment under test. After each measuring cycle over 16 periods you can get 32 values.

10.2.4.1.5.1.7 :PLT? FLLT? PItI

SCPI: :FETCh[:SCALar]:FLICker[:EUTest]:PLT? /qonly/ |
 :READ[:SCALar]:FLICker[:EUTest]:PLT? /qonly/
 SHORT: FLLT? /qonly/

ID:	PItI	Mode:	Flicker
Type:	float	Suffix:	1...4
Value:	n/a	List:	n/a
Unit:	n/a	Group:	n/a

Reads the P_{It} value of the equipment under test.

10.2.4.1.5.1.8 :PMOMentary? FLMS? PmI

SCPI: :FETCh[:SCALar]:FLICker[:EUTest]:PMOMentary?/qonly/ <list> |
 :READ[:SCALar]:FLICker[:EUTest]:PMOMentary? /qonly/ <list>
 SHORT: FLMS? /qonly/ <list>

ID:	PmI	Mode:	Flicker
Type:	float	Suffix:	1...4
Value:	n/a	List:	0...31
Unit:	n/a	Group:	n/a

Reads the momentary flicker level of the equipment under test. After each measuring cycle over 16 periods you can get 32 values.

10.2.4.1.5.1.9 :PST?	FLST?	PstI
-----------------------------	--------------	-------------

SCPI: :FETCh[:SCALar]:FLICker[:EUTest]:PST? /qonly/ |
:READ[:SCALar]:FLICker[:EUTest]:PST? /qonly/
SHORT: FLST? /qonly/

ID:	PstI	Mode:	Flicker
Type:	float	Suffix:	1...4
Value:	n/a	List:	n/a
Unit:	n/a	Group:	n/a

Reads the P_{st} value of the equipment under test.

10.2.4.1.5.1.10 :RESult?	FLRE?	LoadOK
---------------------------------	--------------	---------------

SCPI: :FETCh[:SCALar]:FLICker[:EUTest]:RESult? /qonly/ |
:READ[:SCALar]:FLICker[:EUTest]:RESult? /qonly/
SHORT: FLRE? /qonly/

ID:	n/a	Mode:	Flicker
Type:	long int	Suffix:	1...4
Value:	n/a	List:	n/a
Unit:	n/a	Group:	n/a

Reads the result of the flicker measuring at the equipment under test.

Bit 0: Set if the total evaluation of the flicker fails (=if any of the sub evaluation fails). Cleared otherwise.

Bit 1: Set if at least one P_{st} value was >1.0 , cleared otherwise.

Bit 2: Set if the P_{It} value was >0.65 at the END of the measuring interval, cleared otherwise.

Bit 3: Set if d_{max} was bigger than limit, cleared otherwise.

Bit 4: Set if $d(t)$ was $>3\%$ for more than allowed time, cleared otherwise.

Bit 5: Set if d_c was $> 3\%$, cleared otherwise.

10.2.4.1.5.2 :LTRemain?	FLTR?
--------------------------------	--------------

SCPI: :FETCh[:SCALar]:FLICker:LTRemain? /qonly/ |
:READ[:SCALar]:FLICker:LTRemain? /qonly/
SHORT: FLTR? /qonly/

ID:	n/a	Mode:	Flicker
Type:	long int	Suffix:	n/a
Value:	n/a	List:	n/a
Unit:	s	Group:	n/a

Reads the remaining long time for the flicker measurement.

10.2.4.1.5.3 :PHWave?	FLPH?	Phw
------------------------------	--------------	------------

SCPI: :FETCh[:SCALar]:FLICkEr:PHWave? /qonly/ <list> |
 :READ[:SCALar]:FLICkEr:PHWave? /qonly/ <list>
 SHORT: FLPH? /qonly/ <list>

ID:	Phw	Mode:	Flicker
Type:	float	Suffix:	1...4
Value:	n/a	List:	0...31
Unit:	W	Group:	n/a

Reads the half wave power values. After each measuring cycle over 16 periods you can get 32 values. To get a correct value it is necessary to measure the current with the current channel and not the voltage of a source!

10.2.4.1.5.4 :SOURce

Selects the source's measuring results. They are measured at the current input jacks.

```

:CALCulate
:DISPlay
:FETCh →      [:SCALar] →      :CURRent
:FORMat        :CYCLe
:INITiate      :DINPut
:INPut         :ENERgy
:INSTrument    :FLICkEr →      [:EUTest]
:MEMory        :FREQuency      :LTRemain
:READ →       :HARMonics      :PHWave
:SENSE         :POWer          :SOURce →      :APMoment
:SOURce       :RESistance    :STATe         :DC
:STATus       :SSYSstem      :STRemain     :DELTat
:SYSTem       :VARiable      :DMAX
:TRIGger      [:VOLTage]     :HWTRms
                                     :PLT
                                     :PMOMentary
                                     :PST
                                     :RESult
  
```

10.2.4.1.5.4.1 :APMoment?	FSMO?	Pmoms
----------------------------------	--------------	--------------

SCPI: :FETCh[:SCALar]:FLICkEr:SOURce:APMoment? /qonly/ |
 :READ[:SCALar]:FLICkEr:SOURce:APMoment? /qonly/
 SHORT: FSMO? /qonly/

ID:	Pmoms	Mode:	Flicker
Type:	float	Suffix:	1...4
Value:	n/a	List:	n/a
Unit:	n/a	Group:	n/a

Reads the averaged momentary flicker level of the source. It is averaged over 16 periods.

10.2.4.1.5.4.2 :DC?	FSDC?	dcs
----------------------------	--------------	------------

SCPI: :FETCh[:SCALar]:FLICkEr:SOURce:DC? /qonly/ |
 :READ[:SCALar]:FLICkEr:SOURce:DC? /qonly/
 SHORT: FSDC? /qonly/

ID:	dcS	Mode:	Flicker
Type:	float	Suffix:	1...4
Value:	in %	List:	n/a
Unit:	n/a	Group:	n/a

Reads the d_c value of the source.

10.2.4.1.5.4.3	:DELtAt?	FSDT?	dts
-----------------------	-----------------	--------------	------------

SCPI: :FETCh[:SCALar]:FLICker:SOURce:DELtAt? /qonly/ <list> |
:READ[:SCALar]:FLICker:SOURce:DELtAt? /qonly/ <list>
SHORT: FSDT? /qonly/ <list>

ID:	dts	Mode:	Flicker
Type:	float	Suffix:	1...4
Value:	in %	List:	0...31
Unit:	n/a	Group:	n/a

Reads the $d(t)$ values of the source. After each measuring cycle over 16 periods you can get 32 values.

10.2.4.1.5.4.4	:DMAX?	FSDX?	dmaxs
-----------------------	---------------	--------------	--------------

SCPI: :FETCh[:SCALar]:FLICker:SOURce:DMAX? /qonly/ |
:READ[:SCALar]:FLICker:SOURce:DMAX? /qonly/
SHORT: FSDX? /qonly/

ID:	dmaxs	Mode:	Flicker
Type:	float	Suffix:	1...4
Value:	in %	List:	n/a
Unit:	n/a	Group:	n/a

Reads the d_{max} value of the source.

10.2.4.1.5.4.5	:DTMViolation?	FSMV?	
-----------------------	-----------------------	--------------	--

SCPI: :FETCh[:SCALar]:FLICker:SOURce:DTMViolation? /qonly/ |
:READ[:SCALar]:FLICker:SOURce:DTMViolation? /qonly/
SHORT: FSMV? /qonly/

ID:	n/a	Mode:	Flicker
Type:	long int	Suffix:	1...4
Value:	n/a	List:	n/a
Unit:	n/a	Group:	n/a

Reads the maximum number of half waves for which the $d(t)$ of the source was bigger than allowed in the standard.

10.2.4.1.5.4.6	:HWTRms?	FSRM?	Uhws
-----------------------	-----------------	--------------	-------------

SCPI: :FETCh[:SCALar]:FLICker:SOURce:HWTRms? /qonly/ <list> |

:READ[:SCALar]:FLICker:SOURce:HWTRms? /qonly/ <list>
 SHORT: FSRM? /qonly/ <list>

ID:	Uhws	Mode:	Flicker
Type:	float	Suffix:	1...4
Value:	n/a	List:	0...31
Unit:	V or A depending on measured signal	Group:	n/a

Reads the half wave TRMS values of the source. After each measuring cycle over 16 periods you can get 32 values.

10.2.4.1.5.4.7	:PLT?	FSLT?	Plts
-----------------------	--------------	--------------	-------------

SCPI: :FETCh[:SCALar]:FLICker:SOURce:PLT? /qonly/ |
 :READ[:SCALar]:FLICker:SOURce:PLT? /qonly/
 SHORT: FSLT? /qonly/

ID:	Plts	Mode:	Flicker
Type:	float	Suffix:	n/a
Value:	n/a	List:	n/a
Unit:	n/a	Group:	n/a

Reads the P_{lt} value of the source.

10.2.4.1.5.4.8	:PMOMentary?	FSMS?	Pms
-----------------------	---------------------	--------------	------------

SCPI: :FETCh[:SCALar]:FLICker:SOURce:PMOMentary? /qonly/ <list> |
 :READ[:SCALar]:FLICker:SOURce:PMOMentary? /qonly/ <list>
 SHORT: FSMS? /qonly/ <list>

ID:	Pms	Mode:	Flicker
Type:	float	Suffix:	1...4
Value:	n/a	List:	0...31
Unit:	n/a	Group:	n/a

Reads the momentary flicker level of the source. After each measuring cycle over 16 periods you can get 32 values.

10.2.4.1.5.4.9	:PST?	FSST?	Psts
-----------------------	--------------	--------------	-------------

SCPI: :FETCh[:SCALar]:FLICker:SOURce:PST? /qonly/ |
 :READ[:SCALar]:FLICker:SOURce:PST? /qonly/
 SHORT: FSST? /qonly/

ID:	Psts	Mode:	Flicker
Type:	float	Suffix:	n/a
Value:	n/a	List:	n/a
Unit:	n/a	Group:	n/a

Reads the P_{st} value of the source.

10.2.4.1.5.4.10 :RESult?	FSRE?	SrcOK
---------------------------------	--------------	--------------

SCPI: :FETCh[:SCALAr]:FLICkEr:SOURce:RESult? /qonly/ |
 :READ[:SCALAr]:FLICkEr:SOURce:RESult? /qonly/
 SHORT: FSRE? /qonly/

ID: n/a	Mode: Flicker
Type: long int	Suffix: 1...4
Value: n/a	List: n/a
Unit: n/a	Group: n/a

Reads the result of the flicker measuring at the source.

- Bit 0: Set if the total evaluation of the flicker fails (=if any of the sub evaluation fails). Cleared otherwise.
- Bit 1: Set if at least one P_{st} value was >1.0 , cleared otherwise.
- Bit 2: Set if the P_{It} value was >0.65 at the END of the measuring interval, cleared otherwise.
- Bit 3: Set if d_{max} was bigger than limit, cleared otherwise.
- Bit 4: Set if $d(t)$ was $>3\%$ for more than allowed time, cleared otherwise.
- Bit 5: Set if d_c was $>3\%$, cleared otherwise.

10.2.4.1.5.5 :STATE?	FSTA?	
-----------------------------	--------------	--

SCPI: :FETCh[:SCALAr]:FLICkEr:STATe? /qonly/ | :READ[:SCALAr]:FLICkEr:STATe? /qonly/
 SHORT: FSTA? /qonly/

ID: n/a	Mode: Flicker
Type: long int	Suffix: n/a
Value: n/a	List: n/a
Unit: n/a	Group: n/a

Reads the state of the flicker measuring.

- 0: Reset
- 1: Wait
- 2: Run
- 3: Stop

10.2.4.1.5.6 :STRemain?	FSTR?	
--------------------------------	--------------	--

SCPI: :FETCh[:SCALAr]:FLICkEr:STRemain? /qonly/ |
 :READ[:SCALAr]:FLICkEr:STRemain? /qonly/
 SHORT: FSTR? /qonly/

ID: n/a	Mode: Flicker
Type: long int	Suffix: n/a
Value: n/a	List: n/a
Unit: s	Group: n/a

Reads the remaining short time for the actual short term measurement.

10.2.4.1.6 FREQuency

```

:CALCulate
:DISPlay
:FETCh →      [:SCALar] →      :CURRent
:FORMat        :CYCLe
:INITiate      :DINPut
:INPut         :ENERgy
:INSTrument    :FLICKer
:MEMory        :FREQuency → : FINPut
:READ →      :HARMonics      :SAMPLe
:SENSe         :POWer         [:SSOurce]
:SOURce        :RESistance
:STATus        :SSYStem
:SYSTem        :VARiable
:TRIGger       [:VOLTage]

```

10.2.4.1.6.1 :FINPut?	DIFQ?	DigFrq
------------------------------	--------------	---------------

SCPI: :FETCh[:SCALar]:FREQuency:FINPut? /qonly/ |
:READ[:SCALar]:FREQuency:FINPut? /qonly/
SHORT: DIFQ?/qonly/

ID:	DigFrq	Mode:	All
Type:	float	Suffix:	1, 2
Value:	n/a	List:	n/a
Unit:	Hz	Group:	n/a

Reads the value of frequency input of the processing signal interface.

10.2.4.1.6.2 :SAMPLe?	SMPL?	
------------------------------	--------------	--

SCPI: :FETCh[:SCALar]:FREQuency:SAMPLe? /qonly/ |
:READ[:SCALar]:FREQuency:SAMPLe? /qonly/
SHORT: SMPL? /qonly/

ID:	n/a	Mode:	All
Type:	float	Suffix:	n/a
Value:	n/a	List:	n/a
Unit:	Hz	Group:	optional [,<NRi>], 0=A, 1=B, ...

Reads the sampling frequency of the LMG.

10.2.4.1.6.3 :SSOurce?	FREQ?	f
-------------------------------	--------------	----------

SCPI: :FETCh[:SCALar]:FREQuency[:SSOurce]? /qonly/ |
:READ[:SCALar]:FREQuency[:SSOurce]? /qonly/
SHORT: FREQ? /qonly/

ID:	f	Mode:	All
Type:	float	Suffix:	1...14
Value:	n/a	List:	n/a
Unit:	Hz	Group:	n/a

Reads the frequency of the synchronisation source

10.2.4.1.7 :HARMonics

:CALCulate		
:DISPlay		
:FETCh →	[:SCALar] →	:CURRent
:FORMat		:CYCLe
:INITiate		:DINPut
:INPut		:ENERgy
:INSTrument		:FLICKer
:MEMory		:FREQUency
:READ →		:HARMonics → :AMPower
:SENSe		:POWer :APFactor
:SOURce		:RESistance :CDResult
:STATus		:VARiable :CURRent
:SYSTem	[:VOLTage]	:LTRemain
:TRIGger		:POWer
		[:VOLTage]

10.2.4.1.7.1 :AMPFactor?	HPFM?
---------------------------------	--------------

SCPI: :FETCh[:SCALar]:HARMonics:AMPFactor? /qonly/ |
:READ[:SCALar]:HARMonics:AMPFactor? /qonly/
SHORT: HPFM? /qonly/

ID:	n/a	Mode:	prCE
Type:	float	Suffix:	1...4
Value:	n/a	List:	n/a
Unit:	n/a	Group:	n/a

Reads the maximum smoothed power factor of the harmonic measuring.

10.2.4.1.7.2 :AMPower?	HPM?
-------------------------------	-------------

SCPI: :FETCh[:SCALar]:HARMonics:AMPower? /qonly/ |
:READ[:SCALar]:HARMonics:AMPower? /qonly/
SHORT: HPM? /qonly/

ID:	n/a	Mode:	prCE
Type:	float	Suffix:	1...4
Value:	n/a	List:	n/a
Unit:	W	Group:	n/a

Reads the maximum smoothed power of the harmonic measuring.

10.2.4.1.7.3 :APFactor?	HPFA?
--------------------------------	--------------

SCPI: :FETCh[:SCALar]:HARMonics:APFactor? /qonly/ |
:READ[:SCALar]:HARMonics:APFactor? /qonly/
SHORT: HPFA? /qonly/

ID:	n/a	Mode:	prCE
Type:	float	Suffix:	1...4
Value:	n/a	List:	n/a
Unit:	n/a	Group:	n/a

Reads the smoothed power factor of the harmonic measuring.

10.2.4.1.7.4 :APOWer?	HPAV?
------------------------------	--------------

SCPI: :FETCh[:SCALAr]:HARMonics:APOWer? /qonly/ |
 :READ[:SCALAr]:HARMonics:APOWer? /qonly/
 SHORT: HPAV? /qonly/

ID: n/a	Mode: prCE
Type: float	Suffix: 1...4
Value: n/a	List: n/a
Unit: W	Group: n/a

Reads the smoothed power of the harmonic measuring.

10.2.4.1.7.5 :CDResult?	HENS?
--------------------------------	--------------

SCPI: :FETCh[:SCALAr]:HARMonics:CDResult? /qonly/ |
 :READ[:SCALAr]:HARMonics:CDResult? /qonly/
 SHORT: HENS? /qonly/

ID: n/a	Mode: prCE
Type: long int	Suffix: 1...4
Value: n/a	List: n/a
Unit: n/a	Group: n/a

Reads the class D result of the harmonic measuring:

- Bit 0: Set if the total class D evaluation failed (=if any of the sub evaluation failed). Cleared otherwise.
- Bit 1: Set if the current was for <95% of time under the positive special envelop, cleared otherwise.
- Bit 2: Set if the current was for <95% of time under the negative special envelop, cleared otherwise.
- Bit 3: Set if P>600W, cleared otherwise.
- Bit 4: Set if the total class C evaluation failed (=if any of the sub evaluation failed). Cleared otherwise.
- Bit 5: Set if the 60° condition failed in first halfwave. Cleared otherwise.
- Bit 6: Set if the 65° condition failed in first halfwave. Cleared otherwise.
- Bit 7: Set if the 90° condition failed in first halfwave. Cleared otherwise.
- Bit 8: Set if the peak value in first halfwave is negative. Cleared otherwise.
- Bit 9: Set if the 60° condition failed in second halfwave. Cleared otherwise.
- Bit 10: Set if the 65° condition failed in second halfwave. Cleared otherwise.
- Bit 11: Set if the 90° condition failed in second halfwave. Cleared otherwise.
- Bit 12: Set if the peak value in second halfwave is negative. Cleared otherwise.

10.2.4.1.7.6 :CURRent

:CALCulate		
:DISPlay		
:FETCh →	[:SCALAr] →	:CURRent
:FORMat		:CYCLe
:INITiate		:DINPut

:INPut	:ENERgy		
:INSTrument	:FLICKer		
:MEMory	:FREQuency		
:READ →	:HARMonics →	:AMPower	
:SENSe	:POWer	:APFactor	
:SOURce	:RESistance	:CDResult	
:STATus	:SSYStem	:CURRent →	:AAMPLitude
:SYSTem	:VARiable	:LTRemain	:AFUNDamental
:TRIGger	[:VOLTage]	:POWer	:AMPLitude
		[:VOLTage]	:FPRotz
			:FRESult
			:GFResult
			:LIMit
			:LTResult
			:OLIMit
			:PHASe
			:POHarmonics
			:POLimit
			:SAverage
			:SMOothed
			:STATe
			:THARmonic
			:THDistortion

10.2.4.1.7.6.1 :AAMPLitude? HIAV? laver

SCPI: :FETCh[:SCALar]:HARMonics:CURRent:AAMPLitude? /qonly/ <list> |
 :READ[:SCALar]:HARMonics:CURRent:AAMPLitude? /qonly/ <list>
 SHORT: HIAV? /qonly/ <list>

ID: laver Mode: prCE
 Type: float Suffix: 1...4
 Value: n/a List: 0...40 for harmonic order
 Unit: A Group: n/a

Reads the average amplitude of the harmonics of the current.

10.2.4.1.7.6.2 :AFUNDamental? HIFM?

SCPI: :FETCh[:SCALar]:HARMonics:CURRent:AFUNDamental? /qonly/ |
 :READ[:SCALar]:HARMonics:CURRent:AFUNDamental? /qonly/
 SHORT: HIFM? /qonly/

ID: n/a Mode: prCE
 Type: float Suffix: 1...4
 Value: n/a List: n/a
 Unit: A Group: n/a

Reads the maximum averaged fundamental current of the harmonics.

10.2.4.1.7.6.3 :AMPLitude? HIAM? lh

SCPI: :FETCh[:SCALar]:HARMonics:CURRent:AMPLitude? /qonly/ <list> |
 :READ[:SCALar]:HARMonics:CURRent:AMPLitude? /qonly/ <list>
 SHORT: HIAM? /qonly/ <list>

ID: lh Mode: prCE, HARM100

Type:	float	Suffix:	1...4(prCE), 1...12(HARM100)
Value:	n/a	List:	0...40/99 (prCE/HARM100) for order
Unit:	A	Group:	n/a

Reads the amplitude of the harmonics of the current.

10.2.4.1.7.6.4 :FPRotz?	HFMX?
--------------------------------	--------------

SCPI: :FETCh[:SCALar]:HARMonics:CURRent:FPRotz? /qonly/ <list> |
:READ[:SCALar]:HARMonics:CURRent:FPRotz? /qonly/ <list>
SHORT: HFMX? /qonly/ <list>

ID:	n/a	Mode:	prCE
Type:	float	Suffix:	1...4
Value:	in %	List:	0...40 for harmonic order
Unit:	n/a	Group:	n/a

Reads the maximum duration in percent of a 2.5 minute window while each harmonic was over the 100% limit.

10.2.4.1.7.6.5 :FRESult?	HIFL?
---------------------------------	--------------

SCPI: :FETCh[:SCALar]:HARMonics:CURRent:FRESult? /qonly/ <list> |
:READ[:SCALar]:HARMonics:CURRent:FRESult? /qonly/ <list>
SHORT: HIFL? /qonly/ <list>

ID:	n/a	Mode:	prCE
Type:	long int	Suffix:	1...4
Value:	0...2 ⁴¹ -1	List:	0, 1 for array element
Unit:	n/a	Group:	n/a

Reads the long time result of the fluctuating harmonics of the current. This is an array of 2 long numbers, so that you get a 64 bit result, if you read out both elements. Each bit from 0 to 40 indicates, if the corresponding harmonic has at least one time while the measuring violated the limit for more than 10% of a 2.5 minute window.

10.2.4.1.7.6.6 :GFResult?	HIGF?
----------------------------------	--------------

SCPI: :FETCh[:SCALar]:HARMonics:CURRent:GFResult? /qonly/ |
:READ[:SCALar]:HARMonics:CURRent:GFResult? /qonly/ |
SHORT: HIGF? /qonly/

ID:	n/a	Mode:	prCE
Type:	long int	Suffix:	1...4
Value:	n/a	List:	n/a
Unit:	n/a	Group:	n/a

Reads the global final result of the current check.

Bit 0: Set if the total current evaluation failed (=if any of the sub evaluation failed). Cleared otherwise.

Bit 1: Set if any of the harmonics was > 100% of the allowed limit, cleared otherwise.

- Bit 2: Set if the fluctuating harmonics were for more than 10% of the 2.5 minute window between 100% and 150% of the limit. Cleared otherwise.
- Bit 3: Set if questionable vales (with ‘?’) have occurred. Cleared otherwise.
- Bit 4: Set if measured power was > 110% of defined power. Cleared otherwise. This is only a warning, not an error.
- Bit 5: Set if measured power factor was > 110% of defined power factor. Cleared otherwise. This is only a warning, not an error.
- Bit 6: Set if measured fundamental current was > 110% of defined fundamental current. Cleared otherwise. This is only a warning, not an error.
- Bit 7: Set if measured power was < 90% of defined power. Cleared otherwise.
- Bit 8: Set if measured power factor was < 90% of defined power factor. Cleared otherwise.
- Bit 9: Set if measured fundamental current was < 90% of defined fundamental current. Cleared otherwise.
- Bit 10: Set if any harmonic is > 150% of limits. Cleared otherwise.
- Bit 11: Set if the THD condition of EN61000-3-12 failed. Cleared otherwise.

10.2.4.1.7.6.7 :IAMplitude? HIZA?

SCPI: :FETCh[:SCALar]:HARMonics:CURRent:IAMplitude? /qonly/ <list> |
 :READ[:SCALar]:HARMonics:CURRent:IAMplitude? /qonly/ <list>
 SHORT: HIZA? /qonly/ <list>

ID:	n/a	Mode:	prCE
Type:	float	Suffix:	1...4
Value:	n/a	List:	0...5 for interharmonics number relative to start position
Unit:	A	Group:	n/a

Reads the interharmonics of the current in CE-HRM mode. To define the analysis area see command 10.2.10.8.2, ‘:ISart HNRZ’

10.2.4.1.7.6.8 :LIMit? HILM? IL

SCPI: :FETCh[:SCALar]:HARMonics:CURRent:LIMit? /qonly/ <list> |
 :READ[:SCALar]:HARMonics:CURRent:LIMit? /qonly/ <list>
 SHORT: HILM? /qonly/ <list>

ID:	IL	Mode:	prCE
Type:	float	Suffix:	1...4
Value:	n/a	List:	0...40 for order
Unit:	A	Group:	n/a

Reads the limits of the harmonics of the current.

10.2.4.1.7.6.9 :LTResult? HILT?

SCPI: :FETCh[:SCALar]:HARMonics:CURRent:LTResult? /qonly/ <list> |
 :READ[:SCALar]:HARMonics:CURRent:LTResult? /qonly/ <list>

SHORT: HILT? /qonly/ <list>

ID:	n/a	Mode:	prCE
Type:	long int	Suffix:	1...4
Value:	0...2 ⁴¹ -1	List:	0, 1 for array element
Unit:	n/a	Group:	n/a

Reads the long time result of the harmonics of the current. This is an array of 2 long numbers, so that you get a 64 bit result, if you read out both elements. Each bit from 0 to 40 indicates, if the corresponding harmonic has at least one time while the measuring violated the limit.

10.2.4.1.7.6.10 :OLIMit?	HIOV?
---------------------------------	--------------

SCPI: :FETCh[:SCALar]:HARMonics:CURRent:OLIMit? /qonly/ <list> |
:READ[:SCALar]:HARMonics:CURRent:OLIMit? /qonly/ <list>
SHORT: HIOV? /qonly/ <list>

ID:	n/a	Mode:	prCE
Type:	long int	Suffix:	1...4
Value:	0...2 ⁴¹ -1	List:	0...3 for array element
Unit:	n/a	Group:	n/a

Reads the over limit status of the harmonics of the current. This is an array of 4 long numbers, so that you get two 64 bit results, if you read out the elements 0/1 or 2/3.

For array element 2/3 each bit from 0 to 40 indicates, if the corresponding harmonic has violated the limit in the actual frame ('!' on LMG display).

For array element 0/1 each bit from 0 to 40 indicates, if the corresponding harmonic has violated the 100% limit but is within the 150% limit in the actual frame ('?' on LMG display).

10.2.4.1.7.6.11 :PHASe?	HIPH?	IP
--------------------------------	--------------	-----------

SCPI: :FETCh[:SCALar]:HARMonics:CURRent:PHASe? /qonly/ <list> |
:READ[:SCALar]:HARMonics:CURRent:PHASe? /qonly/ <list>
SHORT: HIPH? /qonly/ <list>

ID:	IP	Mode:	HARM100
Type:	float	Suffix:	1...12
Value:	n/a	List:	0...99 for order
Unit:	°	Group:	n/a

Reads the phase of the harmonics of the current.

10.2.4.1.7.6.12 :POHarmonic?	HPOC?	Ipohc
-------------------------------------	--------------	--------------

SCPI: :FETCh[:SCALar]:HARMonics:CURRent:POHarmonic? /qonly/ |
:READ[:SCALar]:HARMonics:CURRent:POHarmonic? /qonly/
SHORT: HPOC? /qonly/

ID:	Ipohc	Mode:	prCE
Type:	float	Suffix:	1...4
Value:	n/a	List:	n/a
Unit:	A	Group:	n/a

Reads the Partial Odd Harmonic Current.

10.2.4.1.7.6.13 :POLimit?	HLIP?
----------------------------------	--------------

SCPI: :FETCh[:SCALar]:HARMonics:CURRent:POLimit? /qonly/ |
:READ[:SCALar]:HARMonics:CURRent:POLimit? /qonly/
SHORT: HLIP? /qonly/

ID:	n/a	Mode:	prCE
Type:	float	Suffix:	1...4
Value:	n/a	List:	n/a
Unit:	A	Group:	n/a

Reads the partial odd harmonic current which is calculated from the limits at the end of a measuring.

10.2.4.1.7.6.14 :SAverage?	HIAS?
-----------------------------------	--------------

SCPI: :FETCh[:SCALar]:HARMonics:CURRent:SAverage? /qonly/ |
:READ[:SCALar]:HARMonics:CURRent:SAverage? /qonly/
SHORT: HIAS? /qonly/

ID:	n/a	Mode:	prCE
Type:	float	Suffix:	1...4
Value:	n/a	List:	n/a
Unit:	A	Group:	n/a

Reads the smoothed averaged TRMS current.

10.2.4.1.7.6.15 :SMOothed?	HIMA?
-----------------------------------	--------------

SCPI: :FETCh[:SCALar]:HARMonics:CURRent:SMOothed? /qonly/ |
:READ[:SCALar]:HARMonics:CURRent:SMOothed? /qonly/
SHORT: HIMA? /qonly/

ID:	n/a	Mode:	prCE
Type:	float	Suffix:	1...4
Value:	n/a	List:	n/a
Unit:	A	Group:	n/a

Reads the smoothed TRMS current in this measuring mode.

10.2.4.1.7.6.16 :STATE?	HIST?
--------------------------------	--------------

SCPI: :FETCh[:SCALar]:HARMonics:CURRent:STATE? /qonly/ |
:READ[:SCALar]:HARMonics:CURRent:STATE? /qonly/
SHORT: HIST? /qonly/

ID:	n/a	Mode:	prCE
Type:	long int	Suffix:	1...4
Value:	n/a	List:	n/a
Unit:	n/a	Group:	n/a

Reads the actual result of the current check:

Bit 0: Set if the total current evaluation failed (=if any of the sub evaluation failed). Cleared otherwise.

Bit 1: Set if any of the harmonics was > 100% of the allowed limit, cleared otherwise.

Bit 2: Set if the fluctuating harmonics were for more than 10% of the 2.5 minute window between 100% and 150% of the limit. Cleared otherwise.

Bit 3: Set if questionable vales (with '?') have occurred. Cleared otherwise.

Bit 10: Set if any harmonic is > 150% of limits. Cleared otherwise.

10.2.4.1.7.6.17	:THARmonic?	HTHC?	lthc
------------------------	--------------------	--------------	-------------

SCPI: :FETCh[:SCALar]:HARMonics:CURRent:THARmonic? /qonly/ |
:READ[:SCALar]:HARMonics:CURRent:THARmonic? /qonly/
SHORT: HTHC? /qonly/

ID:	lthc	Mode:	prCE
Type:	float	Suffix:	1...4
Value:	n/a	List:	n/a
Unit:	A	Group:	n/a

Reads the Total Harmonic Current.

10.2.4.1.7.6.18	:THDistort?	HIHD?	lthd
------------------------	--------------------	--------------	-------------

SCPI: :FETCh[:SCALar]:HARMonics:CURRent:THDistort? /qonly/ |
:READ[:SCALar]:HARMonics:CURRent:THDistort? /qonly/
SHORT: HIHD? /qonly/

ID:	lthd	Mode:	prCE, Flicker, HARM100
Type:	float	Suffix:	1...4/12
Value:	in %	List:	n/a
Unit:	n/a	Group:	n/a

Reads the THD of the current.

10.2.4.1.7.7	:LTRemain?	HLTR?
---------------------	-------------------	--------------

SCPI: :FETCh[:SCALar]:HARMonics:LTRemain? /qonly/ |
:READ[:SCALar]:HARMonics:LTRemain? /qonly/
SHORT: HLTR? /qonly/

ID:	n/a	Mode:	prCE
Type:	long int	Suffix:	n/a
Value:	n/a	List:	n/a
Unit:	s	Group:	n/a

Reads the remaining long time for the harmonic measurement.

10.2.4.1.7.8 :POWer

:CALCulate				
:DISPlay				
:FETCh →	[:SCALAr] →	:CURRent		
:FORMat		:CYCLe		
:INITiate		:DINPut		
:INPut		:ENERgy		
:INSTrument		:FLICKer		
:MEMory		:FREQuency		
:READ →		:HARMonics →	:AMPower	
:SENSe		:POWer	:APFactor	
:SOURce		:RESistance	:CDResult	
:STATus		SSYSem	:CURRent	
:SYSTem		:VARiable	:LTRemain	
:TRIGger		[:VOLTage]	:POWer →	:ACTive
			[:VOLTage]	:APParent
				:REACTive

10.2.4.1.7.8.1 :ACTive?	HPAM?	Ph
--------------------------------	--------------	-----------

SCPI: :FETCh[:SCALAr]:HARMonics:POWer:ACTive? /qonly/ <list> |
 :READ[:SCALAr]:HARMonics:POWer:ACTive? /qonly/ <list>
 SHORT: HPAM? /qonly/ <list>

ID:	Ph	Mode:	HARM100
Type:	float	Suffix:	1...12
Value:	n/a	List:	0...99 for order
Unit:	W	Group:	n/a

Reads the harmonics of the active power.

10.2.4.1.7.8.2 :APParent?	HSAM?	Sh
----------------------------------	--------------	-----------

SCPI: :FETCh[:SCALAr]:HARMonics:POWer:APParent? /qonly/ <list> |
 :READ[:SCALAr]:HARMonics:POWer:APParent? /qonly/ <list>
 SHORT: HSAM? /qonly/ <list>

ID:	Sh	Mode:	HARM100
Type:	float	Suffix:	1...12
Value:	n/a	List:	0...99 for order
Unit:	VA	Group:	n/a

Reads the harmonics of the apparent power.

10.2.4.1.7.8.3 :DISTortion?	D?	D
------------------------------------	-----------	----------

SCPI: :FETCh[:SCALAr]:HARMonics:POWer:DISTortion? /qonly/ |
 :READ[:SCALAr]:HARMonics:POWer:Distortion? /qonly/
 SHORT: D? /qonly/

ID:	D	Mode:	CE-Harm, HARM100
Type:	float	Suffix:	1...12
Value:	n/a	List:	n/a
Unit:	var	Group:	n/a

Reads the distortion power.

10.2.4.1.7.8.4 :REACTIVE?	HQAM?	Qh
----------------------------------	--------------	-----------

SCPI: :FETCh[:SCALAr]:HARMonics:POWer:REACTIVE? /qonly/ <list> |
 :READ[:SCALAr]:HARMonics:POWer:REACTIVE? /qonly/ <list>
 SHORT: HQAM? /qonly/ <list>

ID:	Qh	Mode:	HARM100
Type:	float	Suffix:	1...12
Value:	n/a	List:	0...99 for order
Unit:	var	Group:	n/a

Reads the harmonics of the reactive power.

10.2.4.1.7.9 [:VOLTage]

```

:CALCulate
:DISPlay
:FETCH →      [:SCALAr] →      :CURRent
:FORMat       :CYCLe
:INITiate     :DINPut
:INPut        :ENERgy
:INSTrument   :FLICKer
:MEMory       :FREQUency
:READ →       :HARMonics →      :AMPower
:SENSe        :POWer             :APFactor
:SOURce       :RESistance       :CDResult
:STATus       :SSYSstem         :CURRent
:SYSTEM       :VARIABLE         :LTRemain
:TRIGger      [:VOLTage]        :Power
                                     [:VOLTage] →      :AMPLitude
                                                         :GFRResult
                                                         :LIMit
                                                         :LTRResult
                                                         :MAMPLitude
                                                         :OLIMit
                                                         :PHASe
                                                         :STATe
                                                         :THDistortion
  
```

10.2.4.1.7.9.1 :AMPLitude?	HUAM?	Uh
-----------------------------------	--------------	-----------

SCPI: :FETCh[:SCALAr]:HARMonics[:VOLTage]:AMPLitude? /qonly/ <list> |
 :READ[:SCALAr]:HARMonics[:VOLTage]:AMPLitude? /qonly/ <list>
 SHORT: HUAM? /qonly/ <list>

ID:	Uh	Mode:	prCE, HARM100
Type:	float	Suffix:	1...4(prCE), 1...12(HARM100)
Value:	n/a	List:	0...40/99 (prCE/HARM100) for order
Unit:	V	Group:	n/a

Reads the amplitude of the harmonics of the voltage.

10.2.4.1.7.9.2 :GFResult?	HUGF?
----------------------------------	--------------

SCPI: :FETCh[:SCALar]:HARMonics[:VOLTage]:GFResult? /qonly/ |
 :READ[:SCALar]:HARMonics[:VOLTage]:GFResult? /qonly/
 SHORT: HUGF? /qonly/

ID:	n/a	Mode:	prCE
Type:	long int	Suffix:	1...4
Value:	n/a	List:	n/a
Unit:	n/a	Group:	n/a

Reads the global final result of the voltage check.

- Bit 0: Set if the total voltage evaluation failed (=if any of the sub evaluation failed). Cleared otherwise.
- Bit 1: Set if any of the harmonics was > 100% of the allowed limit, cleared otherwise.
- Bit 2: Set if the voltage amplitude was not within the limit, cleared otherwise.
- Bit 3: Set if the frequency was not within the limit, cleared otherwise.
- Bit 4: Set if the crest factor was not within the limit, cleared otherwise.
- Bit 5: Set, if the peak value is not within $90^{\circ} \pm 3^{\circ}$

10.2.4.1.7.9.3 :HWCFactor?	FLCF?
-----------------------------------	--------------

SCPI: :FETCh[:SCALar]:HARMonics[:VOLTage]: HWCFactor? /qonly/ <list> |
 :READ[:SCALar]:HARMonics[:VOLTage]: HWCFactor? /qonly/ <list>
 SHORT: FLCF? /qonly/ <list>

ID:	n/a	Mode:	prCE
Type:	float	Suffix:	1...4
Value:	n/a	List:	0...31 for half wave number
Unit:	n/a	Group:	n/a

Reads the voltage crest factor of the half waves. After each measuring cycle over 16 periods you can get 32 values.

10.2.4.1.7.9.4 :IAMPlitude?	HUZA?
------------------------------------	--------------

SCPI: :FETCh[:SCALar]:HARMonics:VOLTage:IAMPlitude? /qonly/ |
 :READ[:SCALar]:HARMonics:VOLTage:IAMPlitude? /qonly/
 SHORT: HUZA? /qonly/

ID:	n/a	Mode:	prCE
Type:	float	Suffix:	0...4
Value:	n/a	List:	0...5 for interharmonics number relative to start position
Unit:	V	Group:	n/a

Reads the interharmonics of the voltage. To define the analysis area see command 10.2.10.8.2, 'ISTart HNRZ'

10.2.4.1.7.9.5 :LIMit?	HULM?	UL
-------------------------------	--------------	-----------

SCPI: :FETCh[:SCALar]:HARMonics[:VOLTage]:LIMit? /qonly/ <list> |
 :READ[:SCALar]:HARMonics[:VOLTage]:LIMit? /qonly/ <list>
 SHORT: HULM? /qonly/ <list>

ID: UL	Mode: prCE
Type: float	Suffix: 1...4
Value: n/a	List: 0...40 for order
Unit: V	Group: n/a

Reads the limits of the harmonics of the voltage.

10.2.4.1.7.9.6 :LTResult?	HULT?	
----------------------------------	--------------	--

SCPI: :FETCh[:SCALar]:HARMonics[:VOLTage]:LTResult? /qonly/ <list> |
 :READ[:SCALar]:HARMonics[:VOLTage]:LTResult? /qonly/ <list>
 SHORT: HULT? /qonly/ <list>

ID: n/a	Mode: prCE
Type: long int	Suffix: 1...4
Value: 0...2 ⁴¹ -1	List: 0, 1 for array element
Unit: n/a	Group: n/a

Reads the long time result of the harmonics of the voltage. This is an array of 2 long numbers, so that you get a 64 bit result, if you read out both elements. Each bit from 0 to 40 indicates, if the corresponding harmonic has at least one time while the measuring violated the limit.

10.2.4.1.7.9.7 :MAMPlitude?	HUMX?	UMax
------------------------------------	--------------	-------------

SCPI: :FETCh[:SCALar]:HARMonics[:VOLTage]:MAMPlitude? /qonly/ <list> |
 :READ[:SCALar]:HARMonics[:VOLTage]:MAMPlitude? /qonly/ <list>
 SHORT: HUMX? /qonly/ <list>

ID: UMax	Mode: prCE
Type: float	Suffix: 1...4
Value: n/a	List: 0...40 for order
Unit: V	Group: n/a

Reads the maximum amplitude of the harmonics of the voltage.

10.2.4.1.7.9.8 :MAXCfactor?	FLCX?	
------------------------------------	--------------	--

SCPI: :FETCh[:SCALar]:HARMonics[:VOLTage]: MAXCfactor? /qonly/ |
 :READ[:SCALar]:HARMonics[:VOLTage]: MAXCfactor? /qonly/
 SHORT: FLCX? /qonly/

ID: n/a	Mode: prCE
Type: float	Suffix: 1...4
Value: n/a	List: n/a
Unit: n/a	Group: n/a

Reads the maximum crest factor of the voltage.

10.2.4.1.7.9.9 :MAXPhi?	FLPX?
--------------------------------	--------------

SCPI: :FETCh[:SCALar]:HARMonics[:VOLTage]: MAXPhi? /qonly/ |
 :READ[:SCALar]:HARMonics[:VOLTage]: MAXPhi? /qonly/
 SHORT: FLPX? /qonly/

ID: n/a	Mode: prCE
Type: float	Suffix: 1...4
Value: n/a	List: n/a
Unit: °	Group: n/a

Reads the maximum phase of peak value of the voltage.

10.2.4.1.7.9.10 :MINCfactor?	FLCN?
-------------------------------------	--------------

SCPI: :FETCh[:SCALar]:HARMonics[:VOLTage]: MINCfactor? /qonly/ |
 :READ[:SCALar]:HARMonics[:VOLTage]: MINCfactor? /qonly/
 SHORT: FLCN? /qonly/

ID: n/a	Mode: prCE
Type: float	Suffix: 1...4
Value: n/a	List: n/a
Unit: n/a	Group: n/a

Reads the minimum crestfactor of the voltage.

10.2.4.1.7.9.11 :MINPhi?	FLPN?
---------------------------------	--------------

SCPI: :FETCh[:SCALar]:HARMonics[:VOLTage]: MINPhi? /qonly/ |
 :READ[:SCALar]:HARMonics[:VOLTage]: MINPhi? /qonly/
 SHORT: FLPN? /qonly/

ID: n/a	Mode: prCE
Type: float	Suffix: 1...4
Value: n/a	List: n/a
Unit: °	Group: n/a

Reads the minimum phase of peak value of the voltage.

10.2.4.1.7.9.12 :OLIMit?	HUOV?
---------------------------------	--------------

SCPI: :FETCh[:SCALar]:HARMonics[:VOLTage]: OLIMit? /qonly/ <list> |
 :READ[:SCALar]:HARMonics[:VOLTage]: OLIMit? /qonly/ <list>
 SHORT: HUOV? /qonly/ <list>

ID: n/a	Mode: prCE
Type: long int	Suffix: 1...4
Value: $0 \dots 2^{41} - 1$	List: 0...3 for array element
Unit: n/a	Group: n/a

Reads the over limit status of the harmonics of the voltage. This is an array of 4 long numbers, so that you get two 64 bit results, if you read out the elements 0/1 or 2/3.

For array element 2/3 each bit from 0 to 40 indicates, if the corresponding harmonic has

violated the limit in the actual frame ('!' on LMG display).

Array elements 0/1 are not used.

10.2.4.1.7.9.13 :PHASe?	HUPH?	UP
--------------------------------	--------------	-----------

SCPI: :FETCh[:SCALar]:HARMonics[:VOLTage]:PHASe? /qonly/ <list> |
:READ[:SCALar]:HARMonics[:VOLTage]:PHASe? /qonly/ <list>
SHORT: HUPH? /qonly/ <list>

ID: UP	Mode: HARM100
Type: float	Suffix: 1...12
Value: n/a	List: 0...99 for order
Unit: °	Group: n/a

Reads the phase of the harmonics of the voltage.

10.2.4.1.7.9.14 :PPHase?	FLUP?	
---------------------------------	--------------	--

SCPI: :FETCh[:SCALar]:HARMonics[:VOLTage]: PPHase? /qonly/ <list> |
:READ[:SCALar]:HARMonics[:VOLTage]: PPHase? /qonly/ <list>
SHORT: FLUP? /qonly/ <list>

ID: n/a	Mode: prCE
Type: float	Suffix: 1...4
Value: n/a	List: 0...31 for half wave number
Unit: °	Group: n/a

Reads the phase angle of the voltage peak value of the half waves. After each measuring cycle over 16 periods you can get 32 values.

10.2.4.1.7.9.15 :STATE?	HUST?	
--------------------------------	--------------	--

SCPI: :FETCh[:SCALar]:HARMonics[:VOLTage]:STATE? /qonly/ |
:READ[:SCALar]:HARMonics[:VOLTage]:STATE? /qonly/ |
SHORT: HUST? /qonly/

ID: n/a	Mode: prCE
Type: long int	Suffix: 1...4
Value: 0...2 ⁵ -1	List: n/a
Unit: n/a	Group: n/a

Reads the actual result of the voltage check

Bit 0: Set if the total voltage evaluation failed (=if any of the sub evaluation failed). Cleared otherwise.

Bit 1: Set if any of the harmonics was > 100% of the allowed limit, cleared otherwise.

Bit 2: Set if the voltage amplitude was not within the limit, cleared otherwise.

Bit 3: Set if the frequency was not within the limit, cleared otherwise.

Bit 4: Set if the crest factor was not within the limit, cleared otherwise.

Bit 5: Set, if the peak value is not within 90°±3°

10.2.4.1.7.9.16 :THDistort?	HUHD?	Uthd
------------------------------------	--------------	-------------

SCPI: :FETCh[:SCALar]:HARMonics[:VOLTage]:THDistort? /qonly/ |
:READ[:SCALar]:HARMonics[:VOLTage]:THDistort? /qonly/
SHORT: HUHD? /qonly/

ID: Uthd	Mode: prCE, Flicker, HARM100
Type: float	Suffix: 1...4/12
Value: in %	List: n/a
Unit: n/a	Group: n/a

Reads the THD of the voltage.

10.2.4.1.8 :POWer

```

:CALCulate
:DISPlay
:FETCH →      [:SCALar] →      :CURRent
:FORMat                :CYCLe
:INITiate                :DINPut
:INPut                :ENERgy
:INSTrument                :FLICKer
:MEMory                :FREQuency
:READ →                :HARMonics
:SENSe                :POWER →      :AACTive
:SOURce                :RESistance  :AAPParent
:STATus                :SSYSstem    [:ACTive]
:SYSTEM                :VARiable    :APParent
:TRIGger                [:VOLTage]   :AREactive
                                :FSCale
                                :ICAPacity
                                :PFACTor
                                :PHASe
                                :REACTive
    
```

10.2.4.1.8.1 :AACTive?	PM?	Pm
-------------------------------	------------	-----------

SCPI: :FETCh[:SCALar]:POWER:AACTive? /qonly/ | :READ[:SCALar]:POWER:AACTive? /qonly/
SHORT: PM? /qonly/

ID: Pm	Mode: Normal
Type: float	Suffix: 1...14
Value: n/a	List: n/a
Unit: W	Group: n/a

Reads the average active power of the energy measuring.

10.2.4.1.8.2 :AAPParent?	SM?	Sm
---------------------------------	------------	-----------

SCPI: :FETCh[:SCALar]:POWER:AAPParent? /qonly/ |
:READ[:SCALar]:POWER:AAPParent? /qonly/
SHORT: SM? /qonly/

ID: Sm	Mode: Normal
Type: float	Suffix: 1...14
Value: n/a	List: n/a
Unit: VA	Group: n/a

Reads the average apparent power of the energy measuring.

10.2.4.1.8.3 [:ACTive]?	P?	P
--------------------------------	-----------	----------

SCPI: :FETCh[:SCALar]:POWer[:ACTive]? /qonly/ | :READ[:SCALar]:POWer[:ACTive]? /qonly/
SHORT: P? /qonly/

ID: P	Mode: All
Type: float	Suffix: 1...14
Value: n/a	List: n/a
Unit: W	Group: n/a

Reads the active power.

10.2.4.1.8.4 :APParent?	S?	S
--------------------------------	-----------	----------

SCPI: :FETCh[:SCALar]:POWer:APParent? /qonly/ | :READ[:SCALar]:POWer:APParent? /qonly/
SHORT: S? /qonly/

ID: S	Mode: All
Type: float	Suffix: 1...14
Value: n/a	List: n/a
Unit: VA	Group: n/a

Reads the apparent power.

10.2.4.1.8.5 :AREactive?	QM?	Qm
---------------------------------	------------	-----------

SCPI: :FETCh[:SCALar]:POWer:AREactive? /qonly/ |
:READ[:SCALar]:POWer:AREactive? /qonly/
SHORT: QM? /qonly/

ID: Qm	Mode: Normal
Type: float	Suffix: 1...14
Value: n/a	List: n/a
Unit: var	Group: n/a

Reads the average reactive power of the energy measuring.

10.2.4.1.8.6 :FSCale?	FSP?	
------------------------------	-------------	--

SCPI: :FETCh[:SCALar]:POWer:FSCale? /qonly/ | :READ[:SCALar]:POWer:FSCale? /qonly/
SHORT: FSP? /qonly/

ID: n/a	Mode: All
Type: float	Suffix: 1...14
Value: n/a	List: n/a
Unit: W	Group: n/a

Reads the full scale value of the power.

10.2.4.1.8.7 :ICAPacity?	INCA?	Inca
---------------------------------	--------------	-------------

SCPI: :FETCh[:SCALar]:POWer:ICAPacity? /qonly/ | :READ[:SCALar]:POWer:ICAPacity? /qonly/
 SHORT: INCA? /qonly/

ID: Inca	Mode: Normal
Type: long int	Suffix: 1...12
Value: -1, 0, +1	List: n/a
Unit: n/a	Group: n/a

Reads the status of the inca flag. It shows, if the system is inductive or capacitive:

+1 inductive
 0 undefined
 -1 capacitive

10.2.4.1.8.8 :PFACtor?	PF?	PF
-------------------------------	------------	-----------

SCPI: :FETCh[:SCALar]:POWer:PFACtor? /qonly/ | :READ[:SCALar]:POWer:PFACtor? /qonly/
 SHORT: PF? /qonly/

ID: PF	Mode: All
Type: float	Suffix: 1...14
Value: n/a	List: n/a
Unit: n/a	Group: n/a

Reads the power factor.

10.2.4.1.8.9 :PHASe?	PHI?	PHI
-----------------------------	-------------	------------

SCPI: :FETCh[:SCALar]:POWer:PHASe? /qonly/ | :READ[:SCALar]:POWer:PHASe? /qonly/
 SHORT: PHI? /qonly/

ID: PHI	Mode: Normal
Type: float	Suffix: 1...12
Value: n/a	List: n/a
Unit: °	Group: n/a

Reads the phase angle in degree between current and voltage.

10.2.4.1.8.10 :REACtive?	Q?	Q
---------------------------------	-----------	----------

SCPI: :FETCh[:SCALar]:POWer:REACtive? /qonly/ | :READ[:SCALar]:POWer:REACtive? /qonly/
 SHORT: Q? /qonly/

ID: Q	Mode: All
Type: float	Suffix: 1...14
Value: n/a	List: n/a
Unit: var	Group: n/a

Reads the reactive power.

10.2.4.1.9 :RESistance

```

:CALCulate
:DISPlay
:FETCh →      [:SCALar] →      :CURRent
:FORMat         :CYCLe
:INITiate       :DINPut
:INPut          :ENERgy
:INSTrument     :FLICKer
:MEMory         :FREQuency
:READ →       :HARMonics
:SENSE          :POWer
:SOURce         :RESistance → :ASResist
:STATus        :SSYSstem      :IMPedance
:SYSTem        :VARiable      :RSIMpedance
:TRIGger       [:VOLTage]

```

10.2.4.1.9.1 :ASResist?	RSER?	Rser
--------------------------------	--------------	-------------

SCPI: :FETCh[:SCALar]:RESistance:ASResist? /qonly/ |
:READ[:SCALar]:RESistance:ASResist? /qonly/
SHORT: RSER? /qonly/

ID:	Rser	Mode:	Normal, prCE, Flicker
Type:	float	Suffix:	1...12
Value:	n/a	List:	n/a
Unit:	Ω	Group:	n/a

Reads the active serial resistance.

10.2.4.1.9.2 :IMPedance?	Z?	Z
---------------------------------	-----------	----------

SCPI: :FETCh[:SCALar]:RESistance:IMPedance? /qonly/ |
:READ[:SCALar]:RESistance:IMPedance? /qonly/
SHORT: Z? /qonly/

ID:	Z	Mode:	Normal, prCE, Flicker
Type:	float	Suffix:	1...12
Value:	n/a	List:	n/a
Unit:	Ω	Group:	n/a

Reads the impedance (apparent resistance).

10.2.4.1.9.3 :RSIMpedance?	XSER?	Xser
-----------------------------------	--------------	-------------

SCPI: :FETCh[:SCALar]:RESistance:RSIMpedance? /qonly/ |
:READ[:SCALar]:RESistance:RSIMpedance? /qonly/
SHORT: XSER? /qonly/

ID:	Xser	Mode:	Normal, prCE, Flicker
Type:	float	Suffix:	1...12
Value:	n/a	List:	n/a
Unit:	Ω	Group:	n/a

Reads the reactive serial impedance.

10.2.4.1.10 :SSYSstem?	RLS?
-------------------------------	-------------

SCPI: :FETCh[:SCALar]:SSYSstem? /qonly/ [<NRi>] | :READ[:SCALar]:SSYSstem? /qonly/ [<NRi>]
 SHORT: RLS? /qonly/

ID: n/a	Mode: Normal
Type: long int	Suffix: n/a
Value: -1, 0, +1	List: n/a
Unit: n/a	Group: optional [<NRi>], 0=A, 1=B, ...

Reads the supply system:

- 0 undefined system
- +1 right rotating system (phase order 1, 2, 3)
- 1 left rotating system (phase order 3, 2, 1)

10.2.4.1.11 :STATE?	TSTA?
----------------------------	--------------

SCPI: :FETCh[:SCALar]:TRANsient:STATE? /qonly/ | :READ[:SCALar]:TRANsient:STATE? /qonly/
 SHORT: TSTA? /qonly/

ID: n/a	Mode: Transient
Type: long int	Suffix: n/a
Value: 0...4	List: n/a
Unit: n/a	Group: optional [<NRi>], 0=A, 1=B, ...

Reads the state of the transient search:

- 0 Idle
- 1 Start: Preparing the transient search. During this time the pretrigger values are stored.
- 2 Search: The pretrigger values are stored, search is running
- 3 PostTrigger: The event was found, the post trigger values are stored.
- 4 Freeze: The values are stored completely.

10.2.4.1.12 :VARIABLE?	VAR?
-------------------------------	-------------

SCPI: :FETCh[:SCALar]:VARIABLE? /qonly/ <list> | :READ[:SCALar]:VARIABLE? /qonly/ <list>
 SHORT: VAR? /qonly/ <list>

ID: The name a user has defined. With script 'abc=Utrms*2;' then ID would be 'abc'	Mode: All
Type: float	Suffix: n/a
Value: n/a	List: 0...11 for array element
Unit: n/a	Group: n/a

Reads value of the user defined variables. They are stored as an array.

10.2.4.1.13 :VNAME?	NVAR?
----------------------------	--------------

SCPI: :FETCh[:SCALar]:VNAME? /qonly/ <string program data> | :READ[:SCALar]:VNAME? /qonly/ <string program data>
 SHORT: NVAR? /qonly/ <string program data>

ID:		Mode:	All
Type:	float	Suffix:	n/a
Value:	n/a	List:	n/a
Unit:	n/a	Group:	n/a

Reads the value of the user defined variable whose name was sent as <string program data>.

Example: You have a variable 'abc'. This can be read by NVAR? „abc“.

10.2.4.1.14 [:VOLTage]

```

:CALCulate
:DISPlay
:FETCH →      [:SCALar] →      :CURRent
:FORMat       :CYCLe
:INITiate     :DINPut
:INPut        :ENERgy
:INSTrument   :FLICKer
:MEMory       :FREQuency
:READ →      :HARMonics
:SENSe       :POWer
:SOURce      :RESistance
:STATus     :SSYStem
:SYSTem     :VARiable
:TRIGger     [:VOLTage] →      :AC
                                     :AINPut
                                     :CFACtor
                                     :DC
                                     :FFACtor
                                     :INRush
                                     :MAXPk
                                     :MINPk
                                     :PPEak
                                     :RECTify
                                     :RUSed
                                     [:TRMS]

```

10.2.4.1.14.1 :AC? UAC? Uac

SCPI: :FETCH[:SCALar][:VOLTage]:AC? /qonly/ | :READ[:SCALar][:VOLTage]:AC? /qonly/
SHORT: UAC? /qonly/

ID:	Uac	Mode:	Normal, prCE
Type:	float	Suffix:	1...12
Value:	n/a	List:	n/a
Unit:	V	Group:	n/a

Reads the AC value of the voltage.

10.2.4.1.14.2 :AINPut? AIVA? Ain

SCPI: :FETCH[:SCALar][:VOLTage]:AINPut? /qonly/ | :READ[:SCALar][:VOLTage]:AINPut? /qonly/
SHORT: AIVA? /qonly/

ID:	Ain	Mode:	All
Type:	float	Suffix:	1...8
Value:	n/a	List:	n/a

Unit: V

Group: n/a

Reads the voltage of the analogue input of the processing signal interface.

10.2.4.1.14.3 :CFACtor?	UCF?	Ucf
--------------------------------	-------------	------------

SCPI: :FETCh[:SCALar][:VOLTage]:CFACtor? /qonly/ |
:READ[:SCALar][:VOLTage]:CFACtor? /qonly/
SHORT: UCF? /qonly/

ID: Ucf	Mode: Normal
Type: float	Suffix: 1...12
Value: n/a	List: n/a
Unit: n/a	Group: n/a

Reads the crest factor of the voltage.

10.2.4.1.14.4 :DC?	UDC?	Udc
---------------------------	-------------	------------

SCPI: :FETCh[:SCALar][:VOLTage]:DC? /qonly/ | :READ[:SCALar][:VOLTage]:DC? /qonly/
SHORT: UDC? /qonly/

ID: Udc	Mode: Normal, prCE
Type: float	Suffix: 1...12
Value: n/a	List: n/a
Unit: V	Group: n/a

Reads the DC value of the voltage.

10.2.4.1.14.5 :FFACtor?	UFF?	Uff
--------------------------------	-------------	------------

SCPI: :FETCh[:SCALar][:VOLTage]:FFACtor? /qonly/ |
:READ[:SCALar][:VOLTage]:FFACtor? /qonly/
SHORT: UFF? /qonly/

ID: Uff	Mode: Normal
Type: float	Suffix: 1...12
Value: n/a	List: n/a
Unit: n/a	Group: n/a

Reads the form factor of the voltage.

10.2.4.1.14.6 :FSCale?	FSU?	
-------------------------------	-------------	--

SCPI: :FETCh[:SCALar][:VOLTage]:FSCale? /qonly/ |
:READ[:SCALar][:VOLTage]:FSCale? /qonly/
SHORT: FSU? /qonly/

ID: n/a	Mode: All
Type: float	Suffix: 1...12
Value: n/a	List: n/a
Unit: V	Group: n/a

Reads the full scale value of the voltage.

10.2.4.1.14.7 :MAXPk?	UMAX?	Upkp
------------------------------	--------------	-------------

SCPI: :FETCh[:SCALar][:VOLTage]:MAXPk? /qonly/ |
:READ[:SCALar][:VOLTage]:MAXPk? /qonly/
SHORT: UMAX? /qonly/

ID:	Upkp	Mode:	Normal
Type:	float	Suffix:	1...12
Value:	n/a	List:	n/a
Unit:	V	Group:	n/a

Reads the biggest sample value of the voltage.

10.2.4.1.14.8 :MINPk?	UMIN?	Upkn
------------------------------	--------------	-------------

SCPI: :FETCh[:SCALar][:VOLTage]:MINPk? /qonly/ | :READ[:SCALar][:VOLTage]:MINPk? /qonly/
SHORT: UMIN? /qonly/

ID:	Upkn	Mode:	Normal
Type:	float	Suffix:	1...12
Value:	n/a	List:	n/a
Unit:	V	Group:	n/a

Reads the smallest sample value of the voltage.

10.2.4.1.14.9 :PHASe?	UPHI?	Uphi
------------------------------	--------------	-------------

SCPI: :FETCh[:SCALar][:VOLTage]:PHASe? /qonly/ | :READ[:SCALar][:VOLTage]:MINPk? /qonly/
SHORT: UPHI? /qonly/

ID:	n/a	Mode:	Normal
Type:	float	Suffix:	1...12
Value:	n/a	List:	n/a
Unit:	°	Group:	n/a

Reads the phase angle of the voltage like displayed in the Fresnel diagram.

10.2.4.1.14.10 :PPEak?	UPP?	Upp
-------------------------------	-------------	------------

SCPI: :FETCh[:SCALar][:VOLTage]:PPEak? /qonly/ | :READ[:SCALar][:VOLTage]:PPEak? /qonly/
SHORT: UPP? /qonly/

ID:	Upp	Mode:	Normal
Type:	float	Suffix:	1...12
Value:	n/a	List:	n/a
Unit:	V	Group:	n/a

Reads the peak peak value of the voltage.

10.2.4.1.14.11 :RECTify?	UREC?	Urect
---------------------------------	--------------	--------------

SCPI: :FETCh[:SCALar][:VOLTage]:RECTify? /qonly/ |
 :READ[:SCALar][:VOLTage]:RECTify? /qonly/
 SHORT: UREC? /qonly/

ID:	Urect	Mode:	Normal
Type:	float	Suffix:	1...12
Value:	n/a	List:	n/a
Unit:	V	Group:	n/a

Reads the rectified value of the voltage.

10.2.4.1.14.12 :RUSed?	OVRU?	OvrU
-------------------------------	--------------	-------------

SCPI: :FETCh[:SCALar][:VOLTage]:RUSed? /qonly/ |
 :READ[:SCALar][:VOLTage]:RUSed? /qonly/
 SHORT: OVRU? /qonly/

ID:	OvrU	Mode:	All
Type:	float	Suffix:	1...12
Value:	in %	List:	n/a
Unit:	n/a	Group:	n/a

Reads the usage of the range in percent.

10.2.4.1.14.13 [:TRMS?]	UTRMS?	Utrms
--------------------------------	---------------	--------------

SCPI: :FETCh[:SCALar][:VOLTage][:TRMS]? /qonly/ |
 :READ[:SCALar][:VOLTage][:TRMS]? /qonly/
 SHORT: UTRMS? /qonly/

ID:	Utrms	Mode:	All
Type:	float	Suffix:	1...14
Value:	n/a	List:	n/a
Unit:	V	Group:	n/a

Reads the TRMS value of the voltage.

10.2.5 :FORMat commands

Here you can setup the output format.

```

:CALCulate
:DISPlay
:FETCh
:FORMat → :DATA
:INITiate
:INPut
:INSTrument
:MEMory
:READ
:SENSe
:SOURce
:STATus
```

```
:SYSTem
:TRIGger
```

10.2.5.1 :DATA

FRMT

```
SCPI: :FORMat:DATA/nquery/ <NRi>
SHORT: FRMT/nquery/ <NRi>
```

ID:	n/a	Mode:	All
Type:	long int	Suffix:	n/a
Value:	0, 1	List:	n/a
Unit:	n/a	Group:	n/a

Defines the data output format. Parameter is:

‘0’ or ‘ASCII’ for ASCII output [*RST default value]

‘1’ or ‘PACKED’ for a packed output.

In the packed output format the data are transmitted as ‘defined length arbitrary block response data’. If the available buffer memory size is too small for the amount of data the LMG wants to send, the data flow will be split in several sequential blocks of data. There are three kinds of data in the blocks: ASCII data, long data (4 Byte) and float data (4 Byte). The numeric data are transferred, so that the receiving PC program can store the data directly in memory. The number 0x11223344 is arranged inside the block as 0x44 0x33 0x22 0x11. This is the order Intel based computers store the number. So if you want to read the number you can simply use a pointer to the input buffer and read the contents of the pointer.

The output changes after the end of the actual program message.

10.2.6 :INITiate commands

Here you can start or stop special actions.

```
:CALCulate
:DISPlay
:FETCh
:FORMat
:INITiate → :CONTinuous
:INPut :COPY
:INSTrument :IMMediate
:MEMory
:READ
:SENSe
:SOURce
:STATus
:SYSTem
:TRIGger
```

10.2.6.1 :CONTinuous

CONT

```
SCPI: :INITiate:CONTinuous <NRi>
SHORT: CONT <NRi>
```

ID:	n/a	Mode:	All
-----	-----	-------	-----

Type:	long int	Suffix:	n/a
Value:	0, 1	List:	n/a
Unit:	n/a	Group:	n/a

This activates or deactivates the continuous execution of the string defined with :TRIGger:ACTion or ACTN. The programmer should only use :FETCh commands, because when CONT is switched to 'ON', automatically an :INITiate:IMMediate is executed at the end of each cycle.

Parameter:

'ON' or '1' activates this mode

'OFF' or '0' deactivates this mode [*RST default value]

The standard defines, that instruments with sequential commands can only exit the 'ON' state by the device clear command of the interface. This works also with this instrument. But additionally you can exit the 'ON' state by setting it to 'OFF' with :INITiate:CONTinuous or CONT.

10.2.6.2 :COPY

COPY

SCPI: :INITiate:COPY/nquery/
SHORT: COPY/nquery/

ID:	n/a	Mode:	All
Type:	n/a	Suffix:	n/a
Value:	n/a	List:	n/a
Unit:	n/a	Group:	n/a

This forces an actualisation of the values to be read with the :FETCh commands. The copying of the data is done immediately and not at the end of the measuring cycle (see also 10.2.6.3, 'IMMediate INIM').

10.2.6.3 :IMMediate

INIM

SCPI: :INITiate:IMMediate/nquery/
SHORT: INIM/nquery/

ID:	n/a	Mode:	All
Type:	n/a	Suffix:	n/a
Value:	n/a	List:	n/a
Unit:	n/a	Group:	n/a

This forces an actualisation of the values to be read with the :FETCh commands. In general the instrument measures continuous. After each cycle the measured values are copied into the display memory. The values read by the :FETCh commands are taken from another copy of the values. This copy is updated, whenever the :INITiate:IMMediate or INIM command is executed. By this it is sure, that all values read with sequential :FETCh commands are from one measuring cycle and belong together.

Please note, that the execution of this command lasts until the end of the cycle. This can take up to one complete cycle. Please keep this in mind when setting any time-out for expecting the answer of a following command.

Please take care to follow this rules:

1. Use just one INIM in one command string to the instrument.
2. Send a second INIM just when the request of the first INIM is answered.

10.2.7 :INPut commands

```
:CALCulate
:DISPlay
:FETCh
:FORMat
:INITiate
::INPut →      :COUPling
:INSTrument
:MEMory
:READ
:SENSe
:SOURce
:STATus
:SYSTem
:TRIGger
```

10.2.7.1 :COUPling

SCPL

SCPI: :INPut:COUPling <NRi>[,<NRi>]
SHORT: SCPL <NRi>[,<NRi>]

ID:	n/a	Mode:	Normal, HARM100
Type:	long int	Suffix:	n/a
Value:	0, 1	List:	n/a
Unit:	n/a	Group:	optional [,<NRi>]; 0=A, 1=B

Sets or queries the setting of the signal coupling. Allowed values are:

‘0’ or ‘ACDC’ for AC+DC coupling [*RST default value]

‘1’ for AC coupling

10.2.8 :INSTrument commands

Here general set-ups of the instrument are done.

```
:CALCulate
:DISPlay
:FETCh
:FORMat
:INITiate
:INPut
::INSTrument → :SElect
:MEMory
:READ
```

```

:SENSe
:SOURce
:STATus
:SYSTem
:TRIGger

```

10.2.8.1 :SElect MODE

SCPI: :INSTrument:SElect <NRi>
SHORT: MODE <NRi>

ID:	n/a	Mode:	All
Type:	long int	Suffix:	n/a
Value:	0...4	List:	n/a
Unit:	n/a	Group:	n/a

Sets or reads the measuring mode:

‘0’ or ‘NORML’ for normal measuring mode [*RST default value]
‘1’ or ‘CEHRM’ for CE harmonic measuring mode
‘2’ or ‘CEFLK’ for CE flicker measuring mode
‘3’ or ‘HRMHUN’ for 100 harmonics measuring mode
‘4’ or ‘TRANS’ for transient measuring mode

Hint

The execution of this command can take up to few seconds. The LMG works internally with a watchdog protection. To prevent that the watchdog becomes active, the ‘MODE’ command should be send as the only command in a message. Just the ‘*OPC?’ can be added to get a feedback, if the command has finished (‘MODE x;*OPC?’).

10.2.9 :MEMory commands

```

:CALCulate
:DISPlay
:FETCh
:FORMat
:INITiate
:INPut
:INSTrument
:MEMory → :FREeze
:READ :SSIZe
:SENSe
:SOURce
:STATus
:SYSTem
:TRIGger

```

10.2.9.1 :FREeze FRZ

SCPI: :MEMory:FREeze <NRi>
SHORT: FRZ <NRi>

ID:	n/a	Mode:	All
Type:	long int	Suffix:	n/a

Value: 0, 1
Unit: n/a

List: n/a
Group: n/a

Freezes the scope RAM. The scope has too much memory so it can't be copied each cycle into a separate buffer. For this reason you should set FRZ to ON when you want to readout the sample values of the scope. Parameter:

'ON' or '1' activates the freeze mode

'OFF' or '0' deactivates the freeze mode [*RST default value]

10.2.9.2 :SSize

GMEM

SCPI: :MEMory:SSize? /qonly/
SHORT: GMEM? /qonly/

ID:	n/a	Mode:	All
Type:	long int	Suffix:	n/a
Value:	0, 2 ¹⁶ , 2 ²² , 2 ²³	List:	n/a
Unit:	n/a	Group:	n/a

Reads the size of the sample value memory.

10.2.10 :SENSe commands

10.2.10.1 :AINPut

```
:CALCulate
:DISPlay
:FETCh
:FORMat
:INITiate
:INPut
:INSTrument
:MEMory
:READ
:SENSe →      :AINPut →      :FSCale
:SOURce       :ARON         :ZERO
:STATus       :AVERage
:SYSTem       :CURRent
:TRIGger      :FILTer
              :FINPut
              :FLICker
              :HARMonics
              :INTegral
              :SWEep
              :TRANsient
              :VOLTage
              :WAVEform
              :WIRing
              :ZPREject
```

10.2.10.1.1 :FSCale

AIHI

SCPI: :SENSe:AINPut:FSCale <NRf>
SHORT: AIHI <NRf>

ID:	n/a	Mode:	All
Type:	float	Suffix:	1...8
Value:	n/a, [*RST default value] = 10	List:	n/a
Unit:	n/a	Group:	n/a

Sets or queries the setting of the full scale of the analogue inputs.

10.2.10.1.2 :ZERO	AILO
--------------------------	-------------

SCPI: :SENSe:AINPut:ZERO <NRf>
 SHORT: AILO <NRf>

ID:	n/a	Mode:	All
Type:	float	Suffix:	1...8
Value:	n/a, [*RST default value] = 0	List:	n/a
Unit:	n/a	Group:	n/a

Sets or queries the setting of the zero position of the analogue inputs.

10.2.10.2 :ARON	ARON
------------------------	-------------

SCPI: :SENSe:ARON <NRi>
 SHORT: ARON <NRi>

ID:	n/a	Mode:	Normal
Type:	long int	Suffix:	n/a
Value:	0, 1	List:	n/a
Unit:	n/a	Group:	n/a

Sets or queries if the aron circuit should be used. Following values are allowed:

- 0: No aron circuit is used
- 1: Aron circuit is used, [*RST default value]

10.2.10.3 :AVERage

```

:CALCulate
:DISPlay
:FETCh
:FORMat
:INITiate
:INPut
:INSTrument
:MEMory
:READ
:SENSe → :AINPut
:SOURce :ARON
:STATus :AVERage → :COUNT
:SYSTem :CURRent
:TRIGger :FILTer
           :FINPut
           :FLICKer
           :HARMonics
           :INTegral
           :SWEep
           :TRANsient
           :VOLTage
    
```

```
:WAVeform
:WIRing
:ZPReject
```

10.2.10.3.1 :COUNT AVER Aver

SCPI: :SENSe:AVERage:COUNT <NRf>
SHORT: AVER <NRf>

ID:	Aver	Mode:	Normal
Type:	float	Suffix:	n/a
Value:	1...999, [*RST default value] = 1	List:	n/a
Unit:	n/a	Group:	n/a

Sets or queries the setting of the average parameter.

10.2.10.4 :CURRENT

```
:CALCulate
:DISPlay
:FETCh
:FORMat
:INITiate
:INPut
:INSTrument
:MEMory
:READ
:SENSe → :AINPut
:SOURce :ARON
:STATus :AVERage
:SYSTem :CURRENT → :DETector
:TRIGger :FILTer :IDENTify
:FINPut :RANGe
:FLICKer :SCALE
:HARMonics
:INTegral
:SWEep
:TRANsient
:VOLTage
:WAVeform
:WIRing
:ZPReject
```

10.2.10.4.1 :DETECTOR IEXT

SCPI: :SENSe:CURRent:DETECTOR <NRi>
SHORT: IEXT <NRi>

ID:	n/a	Mode:	All
Type:	long int	Suffix:	1...4
Value:	0, 1	List:	n/a
Unit:	n/a	Group:	n/a

Reads and sets internal or external sensor input:

‘0’ or ‘INT’ for internal shunt (current input) [*RST default value]

‘1’ or ‘EXT’ for external sensor input (voltage input)

10.2.10.4.2 :IDENTify? IDNI?

SCPI: :SENSe:CURRent:IDENtify? /qonly/
 SHORT: IDNI? /qonly/

ID:	n/a	Mode:	All
Type:	string	Suffix:	1...4
Value:	n/a	List:	n/a
Unit:	n/a	Group:	n/a

Reads the type of the external current sensor.

10.2.10.4.3 :RANGe

```

:CALCulate
:DISPlay
:FETCh
:FORMat
:INITiate
:INPut
:INSTrument
:MEMory
:READ
:SENSe → :AINPut
:SOURce :ARON
:STATus :AVERage
:SYSTem :CURRent → :DETEctor
:TRIGger :FILTer :RANGe → :AUTO
          :FINPut :SCALe :LINTern
          :FLICKer [:UPPer]
          :HARMonics
          :INTegral
          :SWEep
          :TRANsient
          :VOLTage
          :WAVEform
          :WIRing
          :ZPRReject
    
```

10.2.10.4.3.1 :AUTO IAM

SCPI: :SENSe:CURRent:RANGe:AUTO <NRi>
 SHORT: IAM <NRi>

ID:	n/a	Mode:	All
Type:	long int	Suffix:	1...4
Value:	0, 1	List:	n/a
Unit:	n/a	Group:	n/a

Reads and sets the status of the autorange function:

‘0’ or ‘MANUAL’ for manual range selection

‘1’ or ‘AUTO’ for automatic range selection [*RST default value]

10.2.10.4.3.2 :LINTern? IILS?

SCPI: :SENSe:CURRent:RANGe:LINTern?/qonly/

SHORT: IILS/qonly/

ID:	n/a	Mode:	All
Type:	float	Suffix:	1...4
Value:	n/a	List:	n/a
Unit:	A	Group:	n/a

Reads a list with the available ranges. You get several numbers which are separated by colons ‘,’. The first number defines the number of following numbers. If you have selected external sensors, you get the list of their ranges.

10.2.10.4.3.3 [:UPPer]	IRNG	Rngl
-------------------------------	-------------	-------------

SCPI: :SENSe:CURRent:RANGe[:UPPer] <NRf>
SHORT: IRNG <NRf>

ID:	Rngl	Mode:	All
Type:	float	Suffix:	1...4
Value:	n/a	List:	n/a
Unit:	A	Group:	n/a

Reads and sets the range for the current measurement. The parameter is the nominal value of the range.

10.2.10.4.4 :SCALE	ISCA	Iscal
---------------------------	-------------	--------------

SCPI: :SENSe:CURRent:SCALE <NRf>
SHORT: ISCA <NRf>

ID:	Iscal	Mode:	All
Type:	float	Suffix:	1...4
Value:	n/a, [*RST default value] = 1.0	List:	n/a
Unit:	n/a	Group:	n/a

Reads and sets the scaling of the current range.

10.2.10.5 :FILTer

10.2.10.5.1 :AFILter	FAAF
-----------------------------	-------------

SCPI: :SENSe:FILTer:AFILter <NRi>[,<NRi>]
SHORT: FAAF <NRi>[,<NRi>]

ID:	n/a	Mode:	HARM100
Type:	long int	Suffix:	n/a
Value:	0, 1	List:	n/a
Unit:	n/a	Group:	optional [,<NRi>]; 0=A, 1=B, ...

Reads and sets the anti-aliasing-filter settings:

- 0: Anti aliasing filter manual setable (via FILT)
- 1: Anti aliasing filter selection automatically [*RST default value]

10.2.10.5.2 [:LPASSs]

```

:CALCulate
:DISPlay
:FETCh
:FORMat
:INITiate
:INPut
:INSTrument
:MEMory
:READ
:SENSe →      :AINPut
:SOURce        :ARON
:STATus        :AVERage
:SYSTem        :CURRent
:TRIGger       :FILTer →      [ :LPASSs ] →      [ :STATe ]
                :FINPut
                :FLICker
                :HARMonics
                :INTegral
                :SWEep
                :TRANsient
                :VOLTage
                :WAVEform
                :WIRing
                :ZPREject
    
```

10.2.10.5.2.1 [:STATe]	FILT
---------------------------------	-------------

SCPI: :SENSe:FILTer[:LPASS][:STATe] <NRi>[,<NRi>]
 SHORT: FILT <NRi>[,<NRi>]

ID:	n/a	Mode:	Normal, Transient
Type:	long int	Suffix:	n/a
Value:	n/a	List:	n/a
Unit:	n/a	Group:	optional [,<NRi>]; 0=A, 1=B, ...

Reads and sets the filter settings:

- 0: Filter off
- 1: HF Rejection filter on [*RST default value]
- 2: Low pass ‘2kHz’ on
- 3: Low pass ‘9.2kHz’ on
- 4: Low pass ‘60Hz’ on
- 5: Low pass ‘18kHz’ on
- 6: Low pass ‘6kHz’ on
- 7: Low pass ‘2.8kHz’ on
- 8: Low pass ‘1.4kHz’ on
- 9: Low pass ‘700Hz’ on
- 10: Low pass ‘350Hz’ on
- 11: Low pass ‘175Hz’ on
- 12: Low pass ‘87.5Hz’ on
- 13: Low pass ‘30Hz’ on

10.2.10.6 :FINPut

```

:CALCulate
:DISPlay
:FETCh
:FORMat
:INITiate
:INPut
:INSTrument
:MEMory
:READ
:SENSe →      :AINPut
:SOURce        :ARON
:STATus        :AVERage
:SYSTem        :CURRent
:TRIGger       :FILTer
               :FINPut →      :SCALE
               :FLICker
               :HARMonics
               :INTEgral
               :SWEep
               :TRANsient
               :VOLTage
               :WAVEform
               :WIRing
               :ZPREject

```

10.2.10.6.1 :SCALE**DIFS**

SCPI: :SENSe:FINPut:SCALE <NRf>
SHORT: DIFS <NRf>

ID:	n/a	Mode:	All
Type:	float	Suffix:	1, 2
Value:	n/a, [*RST default value] is 1.0	List:	n/a
Unit:	n/a	Group:	n/a

Sets or queries the setting of the scale of the frequency input.

10.2.10.7 :FLICker

```

:CALCulate
:DISPlay
:FETCh
:FORMat
:INITiate
:INPut
:INSTrument
:MEMory
:READ
:SENSe →      :AINPut
:SOURce        :ARON
:STATus        :AVERage
:SYSTem        :CURRent
:TRIGger       :FILTer
               :FINPut
               :FLICker →      :PERiods
               :HARMonics      :STIMe
               :INTEgral
               :SWEep

```

```

:TRANsient
:VOLTage
:WAVeform
:WIRing
:ZPReject
    
```

10.2.10.7.1 :PERiods	FLPS	FlkPer
-----------------------------	-------------	---------------

SCPI: :SENSe:FLICker:PERiods <NRf>
 SHORT: FLPS <NRf>

ID: FlkPer	Mode: Flicker
Type: float	Suffix: n/a
Value: n/a, [*RST default value] = 12	List: n/a
Unit: n/a	Group: n/a

Reads and sets the number of periods for flicker measuring.

10.2.10.7.2 :STIME	FTIM	
---------------------------	-------------	--

SCPI: :SENSe:FLICker:STIME <NRi>
 SHORT: FTIM <NRi>

ID: n/a	Mode: Flicker
Type: long int	Suffix: n/a
Value: n/a, [*RST default value] = 600	List: n/a
Unit: s	Group: n/a

Reads and sets the short term flicker measuring time.

10.2.10.8 :HARMonics

```

:CALCulate
:DISPlay
:FETCh
:FORMat
:INITiate
:INPut
:INSTrument
:MEMory
:READ
:SENSe → :AINPut
:SOURce :ARON
:STATus :AVERage
:SYSTem :CURRent
:TRIGger :FILTer
          :FINPut
          :FLICker
          :HARMonics → :FDIV
          :INTegral :REFerence
          :SWEep :SMOoth
          :TRANsient :TIME
          :VOLTage
          :WAVeform
          :WIRing
          :ZPReject
    
```

10.2.10.8.1 :FDIV	FDIV
--------------------------	-------------

SCPI: :SENSe:HARMonics:FDIV <NRf>[,<NRi>]
 SHORT: FDIV <NRf>[,<NRi>]

ID: n/a	Mode: HARM100
Type: float	Suffix: n/a
Value: 1...50, [*RST default value] = 1	List: n/a
Unit: n/a	Group: optional [,<NRi>]; 0=A, 1=B, ...

Reads and sets the frequency divider ratio.

10.2.10.8.2 :IStart	HNRZ
----------------------------	-------------

SCPI: :SENSe:HARMonics:IStart <NRi>[,<NRi>]
 SHORT: HNRZ <NRi>[,<NRi>]

ID: n/a	Mode: prCE
Type: long int	Suffix: n/a
Value: 0...1000	List: n/a
Unit: n/a	Group: optional [,<NRi>]; 0=A, 1=B, ...

Reads and sets the number of the interharmonic where the analysis range of the interharmonics starts.

10.2.10.8.3 :REFErrence	HREF
--------------------------------	-------------

SCPI: :SENSe:HARMonics:REFErrence <NRi>[,<NRi>]
 SHORT: HREF <NRi>[,<NRi>]

ID: n/a	Mode: HARM100
Type: long int	Suffix: n/a
Value: 0, 1, 20	List: n/a
Unit: n/a	Group: optional [,<NRi>]; 0=A, 1=B, ...

Reads and sets the state of the phase reference for the harmonics and the Fresnel diagram. That defines if the basic wave of U, I or the synchronisation source is set to 0° as reference for the system:

‘0’ for U as reference [*RST default value]
 ‘1’ for I as reference
 ‘20’ for none (=synchronisation source) as reference

10.2.10.8.4 :SMOoth	SMOO
----------------------------	-------------

SCPI: :SENSe:HARMonics:SMOoth <NRi>
 SHORT: SMOO <NRi>

ID: n/a	Mode: prCE
Type: long int	Suffix: n/a
Value: 0, 1	List: n/a
Unit: n/a	Group: n/a

Reads and sets the state of the smoothing:

‘0’ or ‘OFF’ for direct measuring [*RST default value]

‘1’ or ‘ON’ for smoothed measuring

10.2.10.8.5 :TIME	HTIM
--------------------------	-------------

SCPI: :SENSE:HARMonics:TIME <NRi>
 SHORT: HTIM <NRi>

ID: n/a	Mode: prCE
Type: long int	Suffix: n/a
Value: n/a, [*RST default value] = 150	List: n/a
Unit: s	Group: n/a

Reads and sets the harmonics measuring time.

10.2.10.9 :INTEgral

```

:CALCulate
:DISPlay
:FETCh
:FORMat
:INITiate
:INPut
:INSTrument
:MEMory
:READ
:SENSE → :AINPut
:SOURce :ARON
:STATus :AVERage
:SYSTem :CURRent
:TRIGger :FILTer
          :FINPut
          :FLICKer
          :HARMonics
          :INTEgral → :DATE
          :SWEep :INTerval
          :TRANsient :MODE
          :VOLTage :STATe
          :WAVEform :TIME
          :WIRing
          :ZPREject
    
```

10.2.10.9.1 :DATE	INTD
--------------------------	-------------

SCPI: :SENSE:INTEgral:DATE <NRf>,<NRf>,<NRf>
 SHORT: INTD <NRf>,<NRf>,<NRf>

ID: n/a	Mode: Normal
Type: n/a	Suffix: n/a
Value: n/a	List: n/a
Unit: n/a	Group: n/a

Reads and sets the start date for an energy measurement. Example: INTD 2003,02,09 sets the date to the 9th February, 2003.

10.2.10.9.2 :INTERval	INTI
------------------------------	-------------

SCPI: :SENSE:INTEgral:INTERval <NRi>
 SHORT: INTI <NRi>

ID: n/a	Mode: Normal
Type: long int	Suffix: n/a
Value: n/a	List: n/a
Unit: s	Group: n/a

Reads and sets the time interval for an energy measurement.

10.2.10.9.3 :MODE	INTM
--------------------------	-------------

SCPI: :SENSE:INTEgral:MODE <NRi>
 SHORT: INTM <NRi>

ID: n/a	Mode: Normal
Type: long int	Suffix: n/a
Value: 0..4	List: n/a
Unit: n/a	Group: n/a

Reads and sets the integration mode:

0=off [*RST default value]

1=continuous

2=interval

3=periodic

4=summing

10.2.10.9.4 :STATe?	INTS?
----------------------------	--------------

SCPI: :SENSE:INTEgral:STATe? /qonly/
 SHORT: INTS? /qonly/

ID: n/a	Mode: Normal
Type: long int	Suffix: n/a
Value: 0..5	List: n/a
Unit: n/a	Group: n/a

Reads the state of the energy measurement:

0=Reset

1=Wait

2=Start

3=Run

4=Stop

5=Hold

10.2.10.9.5 :TIME	INTT
--------------------------	-------------

SCPI: :SENSE:INTEgral:TIME <NRf>,<NRf>,<NRf>

SHORT: INTT <NRf>,<NRf>,<NRf>

ID:	n/a	Mode:	Normal
Type:	n/a	Suffix:	n/a
Value:	n/a	List:	n/a
Unit:	n/a	Group:	n/a

Reads and sets the start time for an energy measurement. Example: INTT 19,26,49 sets the time to 19:26:49.

10.2.10.10 :RPValues	RPHV
-----------------------------	-------------

SCPI: :SENSe:RPValues <NRi>
 SHORT: RPHV <NRi>

ID:	n/a	Mode:	All
Type:	long int	Suffix:	n/a
Value:	0, 1	List:	n/a
Unit:	n/a	Group:	n/a

By this you can deactivate the rejection of phantom values:

- 0: Phantom values are displayed
- 1: Phantom values are not displayed [*RST default value]

10.2.10.11 :SWEep

```

:CALCulate
:DISPlay
:FETCh
:FORMat
:INITiate
:INPut
:INSTRument
:MEMory
:READ
:SENSe →      :AINPut
:SOURce        :ARON
:STATus        :AVERage
:SYSTem        :CURRent
:TRIGger       :FILTer
               :FINPut
               :FLICker
               :HARMonics
               :INTegral
               :SWEep →      :TIME
               :TRANsient
               :VOLTage
               :WAVEform
               :WIRing
               :ZPREject
    
```

10.2.10.11.1 :TIME	CYCL	Cycle
---------------------------	-------------	--------------

SCPI: :SENSe:SWEep:TIME <NRf>
 SHORT: CYCL <NRf>

ID:	Cycle	Mode:	Normal
Type:	float	Suffix:	n/a
Value:	0, 0.05...60, [*RST default value] = 0.5	List:	n/a
Unit:	s	Group:	n/a

Reads and sets the cycle time.

10.2.10.12 :TRANSient

```

:CALCulate
:DISPlay
:FETCh
:FORMat
:INITiate
:INPut
:INSTrument
:MEMory
:READ
:SENSe →      :AINPut
:SOURce       :ARON
:STATus      :AVERage
:SYSTem      :CURRent
:TRIGger     :FILTer
              :FINPut
              :FLICker
              :HARMonics
              :INTegral
              :SWEep
              :TRANSient → :ACRegister
              :VOLTage     :LIMita
              :WAVEform    :LIMitb
              :WIRing      :CHANnels
              :ZPReject    :DURation
                          :OCRegister
                          :PRETrigger
                          :RTIME
                          :SIGNal
                          :SRDT
                          :SRDY
                          :SROVer

```

10.2.10.12.1 :ACRegister TACR

SCPI: :SENSe:TRANSient:ACRegister <NRi>[,<NRi>]
 SHORT: TACR <NRi>[,<NRi>]

ID:	n/a	Mode:	Transient
Type:	long int	Suffix:	n/a
Value:	0...127, [*RST default value] = 0	List:	n/a
Unit:	n/a	Group:	optional [,<NRi>], 0=A, 1=B

Reads and sets the AND Condition Register:

- Bit 0: Slewrate condition is checked if bit is set
- Bit 1: Win In condition is checked if bit is set
- Bit 2: Win Out condition is checked if bit is set
- Bit 3: >Limit1 condition is checked if bit is set

Bit 4: <Limit1 condition is checked if bit is set

Bit 5: >Limit2 condition is checked if bit is set

Bit 6: <Limit2 condition is checked if bit is set

10.2.10.12.2 :ALIMit TLIA

SCPI: :SENSE:TRANSient:ALIMit <NRf>[,<NRi>]

SHORT: TLIA <NRf>[,<NRi>]

ID:	n/a	Mode:	Transient
Type:	float	Suffix:	n/a
Value:	$\pm 1e9$, [*RST default value] = 0	List:	n/a
Unit:	n/a	Group:	optional [,<NRi>], 0=A, 1=B

Reads and sets the limit 1.

10.2.10.12.3 :BLIMit TLIB

SCPI: :SENSE:TRANSient:BLIMit <NRf>[,<NRi>]

SHORT: TLIB <NRf>[,<NRi>]

ID:	n/a	Mode:	Transient
Type:	float	Suffix:	n/a
Value:	$\pm 1e9$, [*RST default value] = 0	List:	n/a
Unit:	n/a	Group:	optional [,<NRi>], 0=A, 1=B

Reads and sets the limit 2.

10.2.10.12.4 :CHANnels TRCH

SCPI: :SENSE:TRANSient:CHANnels <NRi>

SHORT: TRCH <NRi>

ID:	n/a	Mode:	Transient
Type:	long int	Suffix:	n/a
Value:	0...4095, [*RST default value] = 4095	List:	n/a
Unit:	n/a	Group:	n/a

Reads and sets the channels to be watched in the transient mode. The trigger event can just be defined for a whole group, so you can include (bit set) or exclude (bit reset) the different channels from searching. Each bit defines one channel:

Bit 0: Channel 1

Bit 1: Channel 2,

10.2.10.12.5 :DURation TDUR

SCPI: :SENSE:TRANSient:DURation <NRf>[,<NRi>]

SHORT: TDUR <NRf>[,<NRi>]

ID:	n/a	Mode:	Transient
-----	-----	-------	-----------

Type: float
 Value: $2 \times 10^{-5} \dots 10$, [*RST default value] = 2×10^{-5}
 Unit: s
 Suffix: n/a
 List: n/a
 Group: optional [,<NRi>], 0=A, 1=B

Reads and sets the duration of the event.

10.2.10.12.6 :OCRegister	TOCR
---------------------------------	-------------

SCPI: :SENSE:TRANSient:OCRegister <NRi>[,<NRi>]
 SHORT: TOCR <NRi>[,<NRi>]

ID: n/a	Mode: Transient
Type: long int	Suffix: n/a
Value: 0...127, [*RST default value] = 0	List: n/a
Unit: n/a	Group: optional [,<NRi>], 0=A, 1=B

Reads and sets the OR Condition Register:

- Bit 0: Slewrate condition is checked if bit is set
- Bit 1: Win In condition is checked if bit is set
- Bit 2: Win Out condition is checked if bit is set
- Bit 3: >Limit1 condition is checked if bit is set
- Bit 4: <Limit1 condition is checked if bit is set
- Bit 5: >Limit2 condition is checked if bit is set
- Bit 6: <Limit2 condition is checked if bit is set

10.2.10.12.7 :PRETrigger	TPRE
---------------------------------	-------------

SCPI: :SENSE:TRANSient:PRETrigger <NRf>
 SHORT: TPRE <NRf>

ID: n/a	Mode: Transient
Type: float	Suffix: n/a
Value: 0...100 in %, [*RST default value] = 50	List: n/a
Unit: n/a	Group: n/a

Reads and sets the pretrigger.

10.2.10.12.8 :RTIME	TREC
----------------------------	-------------

SCPI: :SENSE:TRANSient:RTIME <NRf>
 SHORT: TREC <NRf>

ID: n/a	Mode: Transient
Type: float	Suffix: n/a
Value: 0.01...60, [*RST default value] = 0.5	List: n/a
Unit: s	Group: n/a

Reads and sets the record time.

10.2.10.12.9 :SIGNal	TSRC
-----------------------------	-------------

SCPI: :SENSE:TRANSient:SIGNal <NRi>[,<NRi>]
 SHORT: TSRC <NRi>[,<NRi>]

ID: n/a	Mode: Transient
Type: long int	Suffix: n/a
Value: 1, 3, 5...7, [*RST default value] = 5	List: n/a
Unit: n/a	Group: optional [,<NRi>], 0=A, 1=B

Reads and sets the trigger signal source:

1: i²
 3: u²
 5: i
 6: u
 7: p

10.2.10.12.10 :SRDT	TDT
----------------------------	------------

SCPI: :SENSE:TRANSient:SRDT <NRf>[,<NRi>]
 SHORT: TDT <NRf>[,<NRi>]

ID: n/a	Mode: Transient
Type: float	Suffix: n/a
Value: 2×10^{-5} ...1, [*RST default value] = 2×10^{-5}	List: n/a
Unit: s	Group: optional [,<NRi>], 0=A, 1=B

Reads and sets the slew rate dt

10.2.10.12.11 :SRDY	TDU
----------------------------	------------

SCPI: :SENSE:TRANSient:SRDY <NRf>[,<NRi>]
 SHORT: TDU <NRf>[,<NRi>]

ID: n/a	Mode: Transient
Type: float	Suffix: n/a
Value: n/a, [*RST default value] = 1	List: n/a
Unit: n/a	Group: optional [,<NRi>], 0=A, 1=B

Reads and sets the slew rate dy of the signal.

10.2.10.12.12 :SROVer	TDX
------------------------------	------------

SCPI: :SENSE:TRANSient:SROVer <NRf>[,<NRi>]
 SHORT: TDX <NRf>[,<NRi>]

ID: n/a	Mode: Transient
Type: float	Suffix: n/a
Value: 1...15, [*RST default value] = 1	List: n/a
Unit: n/a	Group: optional [,<NRi>], 0=A, 1=B

Reads and sets the slew rate over x value.

10.2.10.13 :VOLTage**10.2.10.13.1 :IDentify IDNU**

SCPI: :SENSE:VOLTage:IDentify? /qonly/
 SHORT: IDNU? /qonly/

ID:	n/a	Mode:	All
Type:	string	Suffix:	1...4
Value:	n/a	List:	n/a
Unit:	n/a	Group:	n/a

Reads the type of an external voltage sensor. The LMG450 will always return „No sensor input“.

10.2.10.13.2 :RANGe

```

:CALCulate
:DISPlay
:FETCh
:FORMat
:INITiate
:INPut
:INSTRument
:MEMory
:READ
:SENSE → :AINPut
:SOURce :ARON
:STATus :AVERage
:SYSTEM :CURRent
:TRIGger :FILTer
           :FINPut
           :FLICKer
           :HARMonics
           :INTEgral
           :SWEep
           :TRANSient
           :VOLTage → :RANGe → :AUTO
           :WAVEform :SCALE :LINTern
           :WIRing [:UPPer]
           :ZPREject
  
```

10.2.10.13.2.1 :AUTO UAM

SCPI: :SENSE:VOLTage:RANGe:AUTO <NRi>
 SHORT: UAM <NRi>

ID:	n/a	Mode:	All
Type:	long int	Suffix:	1...4
Value:	0, 1	List:	n/a
Unit:	n/a	Group:	n/a

Reads and sets the status of the autorange function:

‘0’ or ‘MANUAL’ for manual range selection.

‘1’ or ‘AUTO’ for automatic range selection [*RST default value].

10.2.10.13.2 :LINTern?	UILS?
-------------------------------	--------------

SCPI: :SENSe:VOLTage:RANGe:LINTern?/qonly/
 SHORT: UILS?/qonly/

ID: n/a	Mode: All
Type: float	Suffix: 1...4
Value: n/a	List: n/a
Unit: V	Group: n/a

Reads a list with the available ranges. You get several float numbers which are separated by colons ‘,’. The first number defines the number of following numbers.

10.2.10.13.2.3 [:UPPer]	URNG	RngU
--------------------------------	-------------	-------------

SCPI: :SENSe:VOLTage:RANGe[:UPPer] <NRf>
 SHORT: URNG <NRf>

ID: RngU	Mode: All
Type: float	Suffix: 1...4
Value: n/a	List: n/a
Unit: V	Group: n/a

Reads and sets the range for the voltage measurement. The parameter is the nominal value of the range.

10.2.10.13.3 :SCALE	USCA	Uscal
----------------------------	-------------	--------------

SCPI: :SENSe:VOLTage:SCALE <NRf>
 SHORT: USCA <NRf>

ID: Uscal	Mode: All
Type: float	Suffix: 1...4
Value: n/a, [*RST default value] = 1	List: n/a
Unit: n/a	Group: n/a

Reads and sets the scaling of the voltage range.

10.2.10.14 :WAVeform

```

:CALCulate
:DISPlay
:FETCh
:FORMat
:INITiate
:INPut
:INSTrument
:MEMory
:READ
:SENSe → :AINPut
:SOURce :ARON
:STATus :AVERage
:SYSTem :CURRent
:TRIGger :FILTer
  
```

```

:FINPut
:FLICker
:HARMonics
:INTegral
:SWEEp
:TRANsient
:VOLTage
:WAVEform → :CYCLes
:WIRing      :IUPDate
:ZPREject    :SATRigger
              :SBTRigger
              :SCTRigger
              :SRATe
              :SSAMples
              :WAVE

```

10.2.10.14.1 :CYCLes GMUL

SCPI: :SENSe:WAVEform:CYCLes <NRf>
 SHORT: GMUL <NRf>

ID:	n/a	Mode:	Normal, Transient
Type:	float	Suffix:	n/a
Value:	1...999	List:	n/a
Unit:	n/a	Group:	n/a

Reads or sets the number of cycles for which sample values are stored. In transient mode this value is a sample rate divider.

10.2.10.14.2 :IUPDate SACT

SCPI: :SENSe:WAVEform:IUPDate/nquery/ [<NRi>]
 SHORT: SACT/nquery/ [<NRi>]

ID:	n/a	Mode:	All
Type:	n/a	Suffix:	n/a
Value:	n/a	List:	n/a
Unit:	n/a	Group:	optional [<NRi>], 0=A, 1=B, ...

Requests new information about the scope data. Before this command you should set ‘:MEMory:FREeze ON’. After this command you can use ‘:SENS:WAV:SATR’, ‘:SENS:WAV:SBTR’, ‘:SENS:WAV:SSAM’ and ‘:SENS:WAV:SCTR’.

10.2.10.14.3 :SATRigger? SATR?

SCPI: :SENSe:WAVEform:SATRigger? /qonly/ [<NRi>]
 SHORT: SATR? /qonly/ [<NRi>]

ID:	n/a	Mode:	All
Type:	long int	Suffix:	n/a
Value:	n/a	List:	n/a
Unit:	n/a	Group:	optional [<NRi>], 0=A, 1=B, ...

Reads how many sample values are available after the trigger event. See also ‘:SENS:WAV:IUPD’ for further information.

10.2.10.14.4 :SBTRigger?	SBTR?
---------------------------------	--------------

SCPI: :SENSe:WAVeform:SBTRigger? /qonly/ [<NRi>
 SHORT: SBTR? /qonly/ [<NRi>]

ID: n/a	Mode: All
Type: long int	Suffix: n/a
Value: n/a	List: n/a
Unit: n/a	Group: optional [<NRi>], 0=A, 1=B, ...

Reads how many sample values are available before the trigger event. See also ‘:SENS:WAV:IUPD’ for further information.

10.2.10.14.5 :SCTRigger?	SCTT?
---------------------------------	--------------

SCPI: :SENSe:WAVeform:SCTRigger? /qonly/
 SHORT: SCTT? /qonly/

ID: n/a	Mode: All
Type: long int	Suffix: n/a
Value: 0...2 ³¹ -1	List: n/a
Unit: n/a	Group: n/a

Reads the number of the sample value at the trigger. See also ‘:SENS:WAV:IUPD’ for further information. The sample values of the instrument are counted. At the end of each cycle this counter is stored and can be read by this command. The counter runs up to 2³¹-1 and starts then again at 0. See also 10.2.4.1.2.2, ‘:SNUMber? SCTC?’

You always get the value of group A.

10.2.10.14.6 :SRATE?	GFRQ?
-----------------------------	--------------

SCPI: :SENSe:WAVeform:SRATE? /qonly/
 SHORT: GFRQ? /qonly/

ID: n/a	Mode: All
Type: float	Suffix: n/a
Value: n/a	List: n/a
Unit: n/a	Group: n/a

Reads the record rate of the sampled values.

10.2.10.14.7 :SSAMples	SSAM
-------------------------------	-------------

SCPI: :SENSe:WAVeform:SSAMples <NRi>
 SHORT: SSAM <NRi>

ID: n/a	Mode: All
Type: long int	Suffix: n/a
Value: see below	List: n/a
Unit: n/a	Group: n/a

Reads and sets which sample values are stored in the memory. See also ‘:SENS:WAV:IUPD’ for further information. The parameter has following meaning:

Bit 3: i

Bit 4: u

Bit 5: p

The Bits are counted from 0!

10.2.10.14.8 :WAVE?

WAVE?

SCPI: :SENSe:WAVeform:WAVE? /qonly/ <NRi>,<list>
SHORT: WAVE? /qonly/ <NRi>,<list>

ID:	n/a	Mode:	All
Type:	float	Suffix:	1...12
Value:	n/a	List:	see below
Unit:	n/a	Group:	n/a

Before using this command you should freeze the memory with :MEMory:FReeze, to avoid data losses at long transfer duration. Reads out sample values specified with <NRi>:

4: i

5: u

6: p

The first allowed value in <list> is the value read by :SENSe:WAVeform:SBTRigger?, the last allowed value that read by :SENSe:WAVeform:SATRigger?

10.2.10.15 :WIRing

WIRE

SCPI: :SENSe:WIRing <NRi>
SHORT: WIRE <NRi>

ID:	n/a	Mode:	Normal, HARM100, TRANSIENT
Type:	long int	Suffix:	n/a
Value:	0...7	List:	n/a
Unit:	n/a	Group:	n/a

Sets or queries the wiring of the LMG. Following values are allowed (3 to 7 only with option L45-O6 star to delta conversion!):

0: Wiring ‘4+0’

1: Wiring ‘3+1’ [*RST default value]

2: Wiring ‘2+2’

3: Wiring ‘3+1, U*I*->UΔΔ’

4: Wiring ‘3+1, UΔI*->UΔΔ’

5: Wiring ‘3+1, UΔI*->U*I*’

6: Wiring ‘2+2 UΔI*->UΔΔ’

7: Wiring ‘2+2, UΔI*->U*I*’

10.2.10.16 :ZPReject	ZSUP
-----------------------------	-------------

SCPI: :SENSe:ZPReject <NRi>
 SHORT: ZSUP <NRi>

ID: n/a	Mode: Normal
Type: long int	Suffix: n/a
Value: 0, 1	List: n/a
Unit: n/a	Group: n/a

By this you can deactivate the zero point rejection. It is a long number with following meaning:

- 0: Zero point rejection is switched off
- 1: Zero point rejection is switched on [*RST default value]

10.2.11 :SOURce commands

```

:CALCulate
:DISPlay
:FETCh
:FORMat
:INITiate
:INPut
:INSTrument
:MEMory
:READ
:SENSe
:SOURce → :DIGital
:STATus :VOLTage
:SYSTem
:TRIGger
  
```

10.2.11.1 :DIGital

```

:CALCulate
:DISPlay
:FETCh
:FORMat
:INITiate
:INPut
:INSTrument
:MEMory
:READ
:SENSe
:SOURce → :DIGital → :CONDition
:STATus :VOLTage :LIMit
:SYSTem :VALue
:TRIGger
  
```

10.2.11.1.1 :CONDition	DOCO
-------------------------------	-------------

SCPI: :SOURce:DIGital:CONDition <NRi>
 SHORT: DOCO <NRi>

ID: n/a	Mode: All
Type: long int	Suffix: 1...8
Value: 0...3	List: n/a
Unit: n/a	Group: n/a

Sets or queries the condition of the digital outputs. Possible parameters are:

0: off [*RST default value]
 1: on
 2: >=
 3: <

10.2.11.1.2 :LIMit DOLI

SCPI: :SOURce:DIGital:LIMit <NRf>
 SHORT: DOLI <NRf>

ID:	n/a	Mode:	All
Type:	float	Suffix:	1...8
Value:	n/a, [*RST default value] = 0	List:	n/a
Unit:	n/a	Group:	n/a

Sets or queries the setting of the limits of the digital outputs.

10.2.11.1.3 :VALue DOIX

SCPI: :SOURce:DIGital:VALue <string>
 SHORT: DOIX <string>

ID:	n/a	Mode:	All
Type:	string	Suffix:	1...8
Value:	n/a, [*RST default value] = 'Utrms'	List:	n/a
Unit:	n/a	Group:	n/a

Sets or queries the setting of the value of the digital outputs. As <string> you have to enter the same string as you would enter when using the instrument without interface. So you have to sent a valid ID!

10.2.11.2 :VOLTage

10.2.11.2.1 :SCALE

```

:CALCulate
:DISPlay
:FETCh
:FORMat
:INITiate
:INPut
:INSTrument
:MEMory
:READ
:SENSe
:SOURce → :DIGital
:STATus      :VOLTage → :SCALE → :FSCale
:SYSTem      :VALue      :ZERO
:TRIGger
  
```

10.2.11.2.1.1 :FSCale	AOHI
------------------------------	-------------

SCPI: :SOURce:VOLTage:SCALE:FSCale <NRf>
 SHORT: AOHI <NRf>

ID: n/a	Mode: All
Type: float	Suffix: 1...8
Value: n/a, [*RST default value] = 10	List: n/a
Unit: n/a	Group: n/a

Sets or queries the setting of the full scale of the analogue outputs.

10.2.11.2.1.2 :ZERO	AOLO
----------------------------	-------------

SCPI: :SOURce:VOLTage:SCALE:ZERO <NRf>
 SHORT: AOLO <NRf>

ID: n/a	Mode: All
Type: float	Suffix: 1...8
Value: n/a, [*RST default value] = 0	List: n/a
Unit: n/a	Group: n/a

Sets or queries the setting of the zero position of the analogue outputs.

10.2.11.2.2 :VALue	AOIX
---------------------------	-------------

SCPI: :SOURce:VOLTage:VALue <string>
 SHORT: AOIX <string>

ID: n/a	Mode: All
Type: string	Suffix: 1...8
Value: n/a, [*RST default value] = „Utrms“	List: n/a
Unit: n/a	Group: n/a

Sets or queries the setting of the value of the analogue outputs. As <string> you have to enter the same string as you would enter when using the instrument without interface. So you have to send a valid ID!

10.2.12 :STATus commands

10.2.12.1 :OPERation

```
:CALCulate
:DISPlay
:FETCh
:FORMat
:INITiate
:INPut
:INSTrument
:MEMory
:READ
:SENSe
:SOURce
```

:STATus →	:OPERation →	:CONDition
:SYSTem	:PRESet	:ENABle
:TRIGger	:QUEStionable	[:EVENT]
		:NTRansition
		:PTRansition

10.2.12.1.1 :CONDition? SOC?

SCPI: :STATus:OPERation:CONDition? /qonly/
SHORT: SOC? /qonly/

ID:	n/a	Mode:	All
Type:	long int	Suffix:	n/a
Value:	0...65535	List:	n/a
Unit:	n/a	Group:	n/a

Reads the Operation Status Condition Register.

10.2.12.1.2 :ENABle SOEN

SCPI: :STATus:OPERation:ENABle <NRi>
SHORT: SOEN <NRi>

ID:	n/a	Mode:	All
Type:	long int	Suffix:	n/a
Value:	0...65535	List:	n/a
Unit:	n/a	Group:	n/a

Reads and sets the Operation Status Enable Register.

10.2.12.1.3 [:EVENT]? SOE?

SCPI: :STATus:OPERation[:EVENT]? /qonly/
SHORT: SOE? /qonly/

ID:	n/a	Mode:	All
Type:	long int	Suffix:	n/a
Value:	0...65535	List:	n/a
Unit:	n/a	Group:	n/a

Reads the Operation Status Event Register and clears it.

10.2.12.1.4 :NTRansition SONT

SCPI: :STATus:OPERation:NTRansition <NRi>
SHORT: SONT <NRi>

ID:	n/a	Mode:	All
Type:	long int	Suffix:	n/a
Value:	0...65535	List:	n/a
Unit:	n/a	Group:	n/a

Reads and sets the Operation Status Negative Transition Register.

10.2.12.1.5 :PTRansition SOPT

SCPI: :STATus:OPERation:PTRansition <NRi>
 SHORT: SOPT <NRi>

ID:	n/a	Mode:	All
Type:	long int	Suffix:	n/a
Value:	0...65535	List:	n/a
Unit:	n/a	Group:	n/a

Reads and sets the Operation Status Positive Transition Register.

10.2.12.2 PRESet PRES

SCPI: :STATus:PRESet/nquery/
 SHORT: PRES/nquery/

ID:	n/a	Mode:	All
Type:	n/a	Suffix:	n/a
Value:	n/a	List:	n/a
Unit:	n/a	Group:	n/a

Presets the operation and the query registers. The p-transition registers are filled with 0x7FFF, the n-transition registers with 0x0000 and the enable registers with 0x0000.

10.2.12.3 :QUEStionable

```

:CALCulate
:DISPlay
:FETCh
:FORMat
:INITiate
:INPut
:INSTrument
:MEMory
:READ
:SENSe
:SOURce
::STATus → :OPERation
:SYSTem      :PRESet
:TRIGger     ::QUEStionable → :CONDition
                                       :ENABle
                                       [::EVENT]
                                       :NTRansition
                                       :PTRansition
    
```

10.2.12.3.1 :CONDition? SQC?

SCPI: :STATus:QUEStionable:CONDition? /qonly/
 SHORT: SQC? /qonly/

ID:	n/a	Mode:	All
Type:	long int	Suffix:	n/a
Value:	0...65535	List:	n/a
Unit:	n/a	Group:	n/a

Reads the Questionable Status Condition Register.

10.2.12.3.2 :ENABLE	SQEN
----------------------------	-------------

SCPI: :STATus:QUESTionable:ENABLE <NRi>
SHORT: SQEN <NRi>

ID:	n/a	Mode:	All
Type:	long int	Suffix:	n/a
Value:	0...65535	List:	n/a
Unit:	n/a	Group:	n/a

Reads and sets the Questionable Status Enable Register.

10.2.12.3.3 [:EVENT]?	SQE?
------------------------------	-------------

SCPI: :STATus:QUESTionable[:EVENT]? /qonly/
SHORT: SQE? /qonly/

ID:	n/a	Mode:	All
Type:	long int	Suffix:	n/a
Value:	0...65535	List:	n/a
Unit:	n/a	Group:	n/a

Reads the Questionable Status Event Register and clears it.

10.2.12.3.4 :NTRansition	SQNT
---------------------------------	-------------

SCPI: :STATus:QUESTionable:NTRansition <NRi>
SHORT: SQNT <NRi>

ID:	n/a	Mode:	All
Type:	long int	Suffix:	n/a
Value:	0...65535	List:	n/a
Unit:	n/a	Group:	n/a

Reads and sets the Questionable Status Negative Transition Register.

10.2.12.3.5 :PTRansition	SQPT
---------------------------------	-------------

SCPI: :STATus:QUESTionable:PTRansition <NRi>
SHORT: SQPT <NRi>

ID:	n/a	Mode:	All
Type:	long int	Suffix:	n/a
Value:	0...65535	List:	n/a
Unit:	n/a	Group:	n/a

Reads and sets the Questionable Status Positive Transition Register.

10.2.13 :SYSTem commands

10.2.13.1 :BEEPer

```

:CALCulate
:DISPlay
:FETCh
:FORMat
:INITiate
:INPut
:INSTrument
:MEMory
:READ
:SENSe
:SOURce
:STATus
::SYSTem →      :BEEPer →      :IMMediate
:TRIGger
                :DATE
                :ERRor
                :HELP
                :KEY
                :LANGuage
                :OPTions
                :PHEADER
                :TIME
                :VERSion

```

10.2.13.1.1 :IMMediate **BEEP**

SCPI: :SYSTem:BEEPer:IMMediate/nquery/
 SHORT: BEEP/nquery/

ID:	n/a	Mode:	All
Type:	n/a	Suffix:	n/a
Value:	n/a	List:	n/a
Unit:	n/a	Group:	n/a

Forces the internal beeper to produce a short sound.

10.2.13.2 :DATE **DATE**

SCPI: :SYSTem:DATE <NRf>,<NRf>,<NRf>
 SHORT: DATE <NRf>,<NRf>,<NRf>

ID:	n/a	Mode:	All
Type:	n/a	Suffix:	n/a
Value:	n/a	List:	n/a
Unit:	n/a	Group:	n/a

Reads and sets the system date. Format is DATE yyyy,mm,dd. Example: DATE 2003,02,09 sets the date to the 9th February, 2003.

10.2.13.3 :ERRor

Following errors can occur:

No.	Name	Possible reason; what to do
8	Overrun error at CONT ON	Too many values were requested in a too short time
7	Nested TRIGger:ACTIon not allowed	
6	Action Buffer Overrun	Too many commands after the TRIGger:ACTIon command
5	Command header error; (or maybe wrong path before)	Not existing or misspelled command or wrong SCPI path
4	Formatter output has overrun	Internal error, please contact ZES
2	Parser output has overrun	Internal error, please contact ZES
1	Parser deadlocked	Internal error, please contact ZES
0	No error	-
-101	Invalid character	A '(' or ')' is missing in a <list>
-103	Invalid separator	A wrong character instead of the expected separator (';', ',', ':', '<EOS>', ...)
-110	Command header error	Not existing or misspelled command
-113	Undefined header	There are no default commands to complete the header automatically. You have to enter the complete command
-120	Numeric data error	A number was expected but not send
-123	Exponent too large	Exponent is > 37
-124	Too many digits	Number has more than 9 digits
-131	Invalid suffix	Suffix too big or small
-150	String data error	A'"' is missing
-221	Settings conflict	Setting at the moment impossible. For example to change a measuring range while autorange is active
-222	Data out of range	Happens for example at invalid <list> entries
-224	Illegal parameter value	Happens for example if you want to change to the (not existing) measuring mode 27
other	Illegal error, please inform your supplier	An error in the internal error handling. Please contact ZES

```

:CALCulate
:DISPlay
:FETCh
:FORMat
:INITiate
:INPut
:INSTrument
:MEMory
:READ
:SENSe
:SOURce

```

```

:STATus
:SYSTem → :BEEPer
:TRIGger  :DATE
          :ERRor → :ALL
          :HELP   :COUNT
          :KEY    [:NEXT]
          :LANGuage
          :OPTions
          :PHEADER
          :TIME
          :VERSion
    
```

10.2.13.3.1 :ALL? ERRALL?

SCPI: :SYSTem:ERRor:ALL? /qonly/
 SHORT: ERRALL? /qonly/

ID:	n/a	Mode:	All
Type:	n/a	Suffix:	n/a
Value:	n/a	List:	n/a
Unit:	n/a	Group:	n/a

Reads all errors, including error code and error description, separated by colons out of the error/event queue.

10.2.13.3.2 :COUNT? ERRCNT?

SCPI: :SYSTem:ERRor:COUNT? /qonly/
 SHORT: ERRCNT? /qonly/

ID:	n/a	Mode:	All
Type:	long int	Suffix:	n/a
Value:	n/a	List:	n/a
Unit:	n/a	Group:	n/a

Reads the number of errors in the error/event queue.

10.2.13.3.3 [:NEXT]? ERR?

SCPI: :SYSTem:ERRor[:NEXT]? /qonly/
 SHORT: ERR? /qonly/

ID:	n/a	Mode:	All
Type:	n/a	Suffix:	n/a
Value:	n/a	List:	n/a
Unit:	n/a	Group:	n/a

Reads the oldest entry from the error/event queue, including error code and error description, separated by colons (',').

10.2.13.4 :HELP

```

:CALCulate
:DISPlay
    
```

```

:FEtCh
:FORMat
:INITiate
:INPUt
:INSTrument
:MEMory
:READ
:SENSe
:SOURce
:STATus
:SYSTem → :BEEPer
:TRIGger   :DATE
           :ERRor
           :HELP → :HEADers
           :KEY    :SHEaders
           :LANGuage
           :OPTions
           :PHEADER
           :TIME
           :VERSion

```

10.2.13.4.1 :HEADers? HEAD?

SCPI: :SYSTem:HELP:HEADers? /qonly/
 SHORT: HEAD? /qonly/

ID:	n/a	Mode:	All
Type:	n/a	Suffix:	n/a
Value:	n/a	List:	n/a
Unit:	n/a	Group:	n/a

Returns a list of all SCPI headers. This list is a <defined length arbitrary block response data>. Because this command has a very special output format it should only be used stand alone.

10.2.13.4.2 :SHEaders? SHEAD?

SCPI: :SYSTem:HELP:SHEaders? /qonly/ [<NRi>]
 SHORT: SHEAD? /qonly/ [<NRi>]

ID:	n/a	Mode:	All
Type:	n/a	Suffix:	n/a
Value:	n/a	List:	n/a
Unit:	n/a	Group:	n/a

Returns a list of all SHORT headers. This list is a <defined length arbitrary block response data>. Because this command has a very special output format it should only be used stand alone.

If the optional NRi is '0', then the output is according to SCPI standard. If it is '1' there are additional information in the format 'x;y t':

x, if specified, is the maximum suffix

;y, if specified, is the maximum index

t, if specified, is the data type

10.2.13.5 :KEY KEY

SCPI: :SYSTem:KEY <NRi>
 SHORT: KEY <NRi>

ID:	n/a	Mode:	All
Type:	long int	Suffix:	n/a
Value:	n/a	List:	n/a
Unit:	n/a	Group:	n/a

Queries the last pressed key or simulates the pressing of a key. Valid key numbers are:

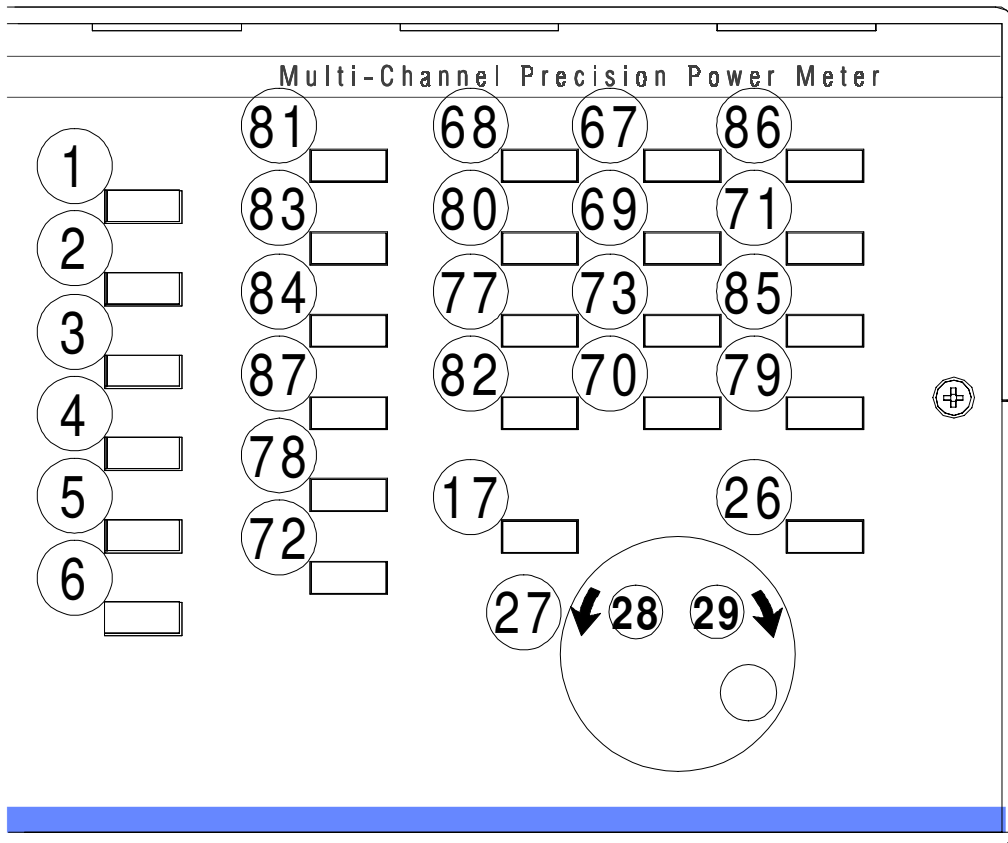

Figure 39: Keynumbers

Please note, that the rotary knob can just be set but not queried!

10.2.13.6 :LANGuage LANG

SCPI: :SYSTem:LANGuage/nquery/ <NRi>
 SHORT: LANG/nquery/ <NRi>

ID:	n/a	Mode:	All
Type:	long int	Suffix:	n/a
Value:	0, 1	List:	n/a
Unit:	n/a	Group:	n/a

Changes the command set to be used. Parameter can be:

- ‘0’ or ‘SCPI’ to go to the SCPI command set
- ‘1’ or ‘SHORT’ to go to the SHORT command set

The new language will be used beginning with the following command header.

There is no *RST default value! The language at power up will be SCPI. A 'device clear' or 'BREAK' will also select SCPI.

10.2.13.7 :OPTions?

OPTN?

SCPI: :SYSTem:OPTions? /qonly/
SHORT: OPTN/qonly/

ID:	n/a	Mode:	All
Type:	long int	Suffix:	n/a
Value:	0...2 ²³ -1	List:	n/a
Unit:	n/a	Group:	n/a

Reads the installed options inside the LMG. The return value is a long parameter where the bits have following function (bit set = option installed):

Bit 0: COM A interface
 Bit 1: COM B interface
 Bit 2: Printer interface
 Bit 3: IEEE488.2 interface
 Bit 4: Memory card drive
 Bit 5: Floppy disk drive
 Bit 6: Processing signal interface 1
 Bit 7: Processing signal interface 2
 Bit 8: Flicker
 Bit 9: Harm100
 Bit 10: Transients
 Bit 11: Extended memory
 Bit 16: Linked values

10.2.13.8 :PHEader

PHDR

SCPI: :SYSTem:PHEader <string program data>
SHORT: PHDR <string program data>

ID:	n/a	Mode:	All
Type:	string	Suffix:	n/a
Value:	n/a	List:	n/a
Unit:	n/a	Group:	n/a

Sets or reads the printer header. At *RST this value is deleted.

For example

PHDR „HELLO“

would cause to output „HELLO“ before each printing.

10.2.13.9 :TIME	TIME
------------------------	-------------

SCPI: :SYSTem:TIME <NRf>,<NRf>,<NRf>
 SHORT: TIME <NRf>,<NRf>,<NRf>

ID: n/a	Mode: All
Type: n/a	Suffix: n/a
Value: n/a	List: n/a
Unit: n/a	Group: n/a

Reads and sets the system time. Format is TIME hh,mm,ss. Example: TIME 10,26,46 sets the time to 10:26:46.

10.2.13.10 :VERSion?	VER?
-----------------------------	-------------

SCPI: :SYSTem:VERSion? /qonly/
 SHORT: VER? /qonly/

ID: n/a	Mode: All
Type: n/a	Suffix: n/a
Value: 1999.0	List: n/a
Unit: n/a	Group: n/a

Returns the version of the SCPI implementation. Returns always '1999.0'.

10.2.14 :TRIGger commands

- :CALCulate
- :DISPlay
- :FETCh
- :FORMat
- :INITiate
- :INPut
- :INSTrument
- :MEMory
- :READ
- :SENSe
- :SOURce
- :STATus
- :SYSTem
- :TRIGger** → :ACTion
- :ICURrent
- :INTerval
- [:SEQuence]

10.2.14.1 :ACTion	ACTN
--------------------------	-------------

SCPI: :TRIGger:ACTion/nquery/
 SHORT: ACTN/nquery/

ID: n/a	Mode: All
Type: n/a	Suffix: n/a
Value: n/a	List: n/a
Unit: n/a	Group: n/a

Defines an action which has to be performed, when :INIT:CONT is set to ON and a trigger event occurs. All program headers which follow behind the ‘;’ after TRIG:ACT will be used, until the end of the program message.

Example: ACTN;UTRMS?;ITRMS?

This defines that each time a trigger event occurs in the INIT:CONT ON state, the TRMS values of voltage and current are returned. See also 10.2.6.1, ‘:CONTinuous CONT’. The same example in SCPI syntax would be.

:TRIG:ACT;:FETC:TRMS?;:FETC:CURR:TRMS?

There is no *RST default value!

10.2.14.2 :ICURrent

IINC

SCPI: :TRIGger:ICURrent/nquery/
SHORT: IINC/nquery/

ID:	n/a	Mode:	All
Type:	n/a	Suffix:	n/a
Value:	n/a	List:	n/a
Unit:	n/a	Group:	n/a

Triggers the measuring of the inrush current. The value for the inrush current is reset to 0. See also 10.2.4.1.1.6

10.2.14.3 :INTerval

```
:CALCulate
:DISPlay
:FETCh
:FORMat
:INITiate
:INPut
:INSTrument
:MEMory
:READ
:SENSe
:SOURce
:STATus
:SYSTem
:TRIGger → :ACTion
           :ICURrent
           :INTerval → :RESet
           [:SEQuence] :STARt
           :STOP
```

10.2.14.3.1 :RESet

RESET

SCPI: :TRIGger:INTerval:RESet/nquery/
SHORT: RESET/nquery/

ID:	n/a	Mode:	Normal
Type:	n/a	Suffix:	n/a

Value: n/a
Unit: n/a

List: n/a
Group: n/a

Resets the energy measurement.

10.2.14.3.2 :START

START

SCPI: :TRIGger:INTerval:START/nquery/
SHORT: START/nquery/

ID: n/a
Type: n/a
Value: n/a
Unit: n/a

Mode: Normal, prCE, Flicker, Transient
Suffix: n/a
List: n/a
Group: n/a

Starts a time dependent measuring (e.g. energy, flicker, ...)

Note: Usually you have lots of configuration before a start. This can take some time to set up. So start will be executed after all configuration has been done. This can be much later than sending the command. To prevent this, it can be useful to have a *OPC? and to wait for the answer before a START command. By this the point of execution is much closer to the time when sending the command.

10.2.14.3.3 :STOP

STOP

SCPI: :TRIGger:INTerval:STOP/nquery/
SHORT: STOP/nquery/

ID: n/a
Type: n/a
Value: n/a
Unit: n/a

Mode: Normal, prCE, Flicker, Transient
Suffix: n/a
List: n/a
Group: n/a

Stops a time dependent measuring (e.g. energy, flicker, ...)

10.2.14.4 [:SEquence]

```
:CALCulate
:DISPlay
:FEtCh
:FORMat
:INITiate
:INPut
:INSTrument
:MEMory
:READ
:SENSe
:SOURce
:STATus
:SYSTem
:TRIGger → :ACTion
             :ICURrent
             :INTerval
```

```

[:SEquence] → :COUple
               :EXTend
               :SOURce

```

10.2.14.4.1 :COUple COUPL

SCPI: :TRIGger[:SEquence]:COUple <NRi>[,<NRi>]

SHORT: COUPL <NRi>[,<NRi>]

ID:	n/a	Mode:	Normal, HARM100, Transient
Type:	long int	Suffix:	n/a
Value:	see below	List:	n/a
Unit:	n/a	Group:	optional [,<NRi>], 0=A, 1=B, ...

Sets or reads the coupling mode for the trigger (synchronisation) signal. Possible values are:

- '0' or 'ACDC' for AC/DC coupling mode [*RST default value]
- '4' for Low pass filter < 300Hz
- '6' for Low pass filter < 80Hz
- '8' for High pass filter > 10Hz
- '10' for High pass filter > 30Hz
- '12' for Band pass 10 - 300Hz
- '13' for Amplitude modulation 10 - 300Hz
- '14' for Band pass 30 - 80Hz

10.2.14.5 :EXTend

```

:CALCulate
:DISPlay
:FETCh
:FORMat
:INITiate
:INPut
:INSTrument
:MEMory
:READ
:SENSe
:SOURce
:STATus
:SYSTem
:TRIGger → :ACTion
           :ICURrent
           :INTerval
           [:SEquence] → :COUple
                        :EXTend → :FILTer
                        :SOURce  :HYSTeresis
                        :LEVel
                        :SOURce

```

10.2.14.5.1 :FILTer TRDF

SCPI: :TRIGger[:SEquence]:EXTend:FILTer <NRi>[,<NRi>]

SHORT: TRDF <NRi>[,<NRi>]

ID:	n/a	Mode:	Normal, HARM100, Transient
Type:	long int	Suffix:	n/a
Value:	0...13	List:	n/a

Unit: n/a

Group: optional [,<NRi>], 0=A, 1=B, ...

Reads and sets the filter of the extended trigger.

- 0: Filter off
- 1: HF rejection filter on [*RST default value]
- 2: Low pass '2kHz' on
- 3: Low pass '9.2kHz' on
- 4: Low pass '60Hz' on
- 5: Low pass '18kHz' on
- 6: Low pass '6kHz' on
- 7: Low pass '2.8kHz' on
- 8: Low pass '1.4kHz' on
- 9: Low pass '700Hz' on
- 10: Low pass '350Hz' on
- 11: Low pass '175Hz' on
- 12: Low pass '87.5Hz' on
- 13: Low pass '30Hz' on

10.2.14.5.2 :HYSTeresis	TRDH
--------------------------------	-------------

SCPI: :TRIGger[:SEquence]:EXTend:HYSTeresis <NRf>[,<NRi>]

SHORT: TRDH <NRf>[,<NRi>]

ID: n/a

Mode: Normal, HARM100, Transient

Type: float

Suffix: n/a

Value: n/a

List: n/a

Unit: n/a

Group: optional [,<NRi>], 0=A, 1=B, ...

Reads and sets the hysteresis of the extended trigger.

10.2.14.5.3 :LEVel	TRDL
---------------------------	-------------

SCPI: :TRIGger[:SEquence]:EXTend:LEVel <NRf>[,<NRi>]

SHORT: TRDL <NRf>[,<NRi>]

ID: n/a

Mode: Normal, HARM100, Transient

Type: float

Suffix: n/a

Value: n/a

List: n/a

Unit: n/a

Group: optional [,<NRi>], 0=A, 1=B, ...

Reads and sets the level of the extended trigger.

10.2.14.5.4 :SOURce	TRDE
----------------------------	-------------

SCPI: :TRIGger[:SEquence]:EXTend:SOURce <NRi>[,<NRi>]

SHORT: TRDE <NRi>[,<NRi>]

ID: n/a

Mode: Normal, HARM100, Transient

Type:	long int	Suffix:	n/a
Value:	0...7	List:	n/a
Unit:	n/a	Group:	optional [,<NRi>], 0=A, 1=B, ...

Reads and sets the source of the extended trigger.

Valid values are:

'0' = is
 '1' = is*is
 '2' = us
 '3' = us*us
 '4' = ps
 '5' = i
 '6' = u
 '7' = p

10.2.14.5.5 :SOURce SYNC

SCPI: :TRIGger[:SEQuence]:SOURce <NRi>[,<NRi>]
 SHORT: SYNC <NRi>[,<NRi>]

ID:	n/a	Mode:	Normal, HARM100, Transient
Type:	long int	Suffix:	n/a
Value:	0...4	List:	n/a
Unit:	n/a	Group:	optional [,<NRi>], 0=A, 1=B, ...

Sets or reads the synchronisation source. Possible values are:

'0' or 'LINE' for line synchronisation
 '1' or 'EXTS' for external synchronisation
 '2' or 'U' for synchronisation to the voltage signal [*RST default value]
 '3' or 'I' for synchronisation to the current signal
 '4' or 'XTRIG' for synchronisation to the Extended trigger

10.2.15 Special commands

10.2.15.1 :GTL GTL

SCPI: :GTL /nquery/
 SHORT: GTL /nquery/

ID:	n/a	Mode:	All
Type:	n/a	Suffix:	n/a
Value:	n/a	List:	n/a
Unit:	n/a	Group:	n/a

Sets the instrument back to the local state (**go to local**). This should be the last command of a remote control sequence

10.2.15.2 :LEN**LEN**

SCPI: :LEN/nquery/
 SHORT: LEN/nquery/

ID:	n/a	Mode:	All
Type:	n/a	Suffix:	n/a
Value:	n/a	List:	n/a
Unit:	n/a	Group:	n/a

Initiates the LMG's remote state but adjustments made via the front panel keyboard of the meter will also be accepted (local **enable**). It depends on the applications if it is useful or not.

10.2.16 Example 1

Following you find a small example for periodic data exchange via RS232 interface:

```
' QBasic 1.1
' Example for reading data from a LMG95/450/500
' LMG should be set to following:
' MEASURING Menu
' Normal measuring mode, 500ms cycle time
' IF/IO (OPTIONS) Menu
' Remote Device: COM1 RS232
' Dev.: COM1: 9600 Baud, EOS <lf>, Echo off, Protocol None
' Connect COM1 of your PC to COM1 of LMG with a 1:1 cable (all pins
' connected, no NULL modem).

DECLARE FUNCTION readans$ ()
OPEN "COM1:9600,N,8,1,ASC,CD0,CS0,DS0,OP0,RS,TB2048,RB4096" FOR RANDOM AS #1
PRINT #1, "syst:lang short" + CHR$(10); ' Change command set
PRINT #1, "actn;utrms?;itrms?" + CHR$(10); ' Request Utrms and Itrms
PRINT #1, "cont on" + CHR$(10); ' Continue output
DO
  answer$ = readans$ ' Read answer from LMG
  val1 = VAL(answer$) ' Calculate values
  val2 = VAL(MID$(answer$, 1 + INSTR(1, answer$, ";"))
  PRINT USING "Answer:& Value1: ###.###V Value2: ##.####A"; readans$; val1; val2
LOOP UNTIL INKEY$ = CHR$(32) ' Loop, until SPACE bar pressed
PRINT #1, "cont off" + CHR$(10); ' Stop continue output
SLEEP 1
PRINT #1, "gt1" + CHR$(10); ' Go back to local mode
CLOSE #1

FUNCTION readans$
  answer$ = ""
  DO
    a$ = INPUT$(1, 1) ' Read character from interface
    IF a$ <> CHR$(10) THEN ' If it is not the EOS character
      answer$ = answer$ + a$ ' add character to answer string
    END IF
  LOOP WHILE a$ <> CHR$(10) ' Loop until EOS is reached
  readans$ = answer$ ' return answer
END FUNCTION
```

10.2.17 Example 2

Following you find a small example for one time data exchange via RS232 interface. Additionally to the SCPI commands you find the same functionality in SHORT syntax.

```
' QBasic 1.1
' Example for reading data from a LMG95/450/500
' LMG should be set to following:
' MEASURING Menu
' Normal measuring mode, 500ms cycle time
' IF/IO (OPTIONS) Menu
' Remote Device: COM1 RS232
' Dev.: COM1: 9600 Baud, EOS <lf>, Echo off, Protocol None
' Connect COM1 of your PC to COM1 of LMG with a 1:1 cable (all pins
' connected, no NULL modem).

DECLARE FUNCTION readans$ ()
OPEN "COM1:9600,N,8,1,ASC,CD0,CS0,DS0,OP0,RS,TB2048,RB4096" FOR RANDOM AS #1
PRINT #1, "READ:CURRENT:TRMS;:FETCH:VOLTAGE:TRMS" + CHR$(10); 'Request values
(SCPI)
'PRINT #1, "SYST:LANG SHORT" + CHR$(10);           'Change Language to SHORT
'PRINT #1, "INIM;ITRMS?;UTRMS?" + CHR$(10);       'Request values (SHORT)
DO
  answer$ = readans$                               ' Read answer from LMG
  val1 = VAL(answer$)                              ' Calculate values
  val2 = VAL(MID$(answer$, 1 + INSTR(1, answer$, ";"))
  PRINT USING "Answer:& Value1: ##.####A Value2: ###.###V"; readans$; val1; val2
LOOP UNTIL INKEY$ = CHR$(32)                       ' Loop, until SPACE bar pressed
PRINT #1, "gt1" + CHR$(10);                        ' Go back to local mode
CLOSE #1

FUNCTION readans$
  answer$ = ""
  DO
    a$ = INPUT$(1, 1)                              ' Read character from interface
    IF a$ <> CHR$(10) THEN                          ' If it is not the EOS character
      answer$ = answer$ + a$                        ' add character to answer string
    END IF
  LOOP WHILE a$ <> CHR$(10)                          ' Loop until EOS is reached
  readans$ = answer$                               ' return answer
END FUNCTION
```

10.2.18 Testing the interface using a terminal program

For testing the interface, or how any commands work it is recommended to use a terminal program (e.g. Hyperterminal under WINDOWS).

Setup the LMG450 pressing *IF/IO* several times until you reach the IF/IO menu. With **IF** you reach the setup menu. If the instrument should be in the remote state switch it back to local by **Goto Local**. Choose the profile 'ComA: Terminal' and connect the ComA jack with a 1:1 cable to your PC.

Now setup you computer. Start you terminal program and set it up to 9600Baud, 8Data Bit, 1Stop Bit, No Parity and No Protocol. Select the correct com port of your computer.

If you now type in ‘*IDN?’ and press Return, the status bar of LMG450 should change from ‘Active Local’ to ‘Active Remote’. If not, check if the characters you typed in are echoed on your screen or not.

If everything is ok, then you get an answer string with the manufacturer, the device, the serial number and the software version.

If all this fails, check all settings and cables and try again.

10.2.19 SCPI command Example

This shows you as an example (in SCPI language), what you could send, what the instrument should answer and some comments about this. Some of the responses like measuring values depend on measured signals, so they may be different, if you try this examples. This examples work with a new powered on instrument (no commands before!). For testing some functions we recommend to use the RS232 interface, because it is much more simple to use than the IEEE interface. In principal the example works with both interfaces. This should help you to program your requests and to understand how to communicate with the instrument.

Two comments on the syntax in the ‘Sent’ column: A ‘ ’ stands for a space character, a ‘␣’ for the <cr> (carriage return) character (which is the enter key, if you use for example a RS232 terminal-program on your PC).

No.	Sent	Received	Comments
1	*rst␣		Reset the instrument to it’s default values. After this first command the instrument changes to the remote state.
2	*idn?␣	ZES ZIMMER Electronic Systems GmbH, LMG450, serial number, version	You ask the instrument for it’s identification.
3a	fetc:volt:trmsn?␣	0	Reads out the voltage of channel n (=1,2,...). You don’t get the actual value, because there has been no values copied to the interface buffer
3b	read:volt:trmsn?␣	220.34	Waits until the end of the measuring cycle, copies the values of channel n to the interface buffer and outputs the actual voltage
3c	fetc:volt:trmsn?␣	220.34	No values were copied to the interface buffer, so you get the same result!

No.	Sent	Received	Comments
4a	read:volt:trmsn?;read:curr:trmsn?↵	220.21;0.6437	Waits until the end of the measuring cycle, copies the values of channel n to the interface buffer and outputs the actual voltage. Then the instrument waits until the end of the next measuring cycle, copies the values to the interface buffer and outputs the actual current. The voltage and current are from different measuring cycles!!
4b	read:volt:trmsn?;fetc:curr:trmsn?↵	221.13;0.6432	Waits until the end of the measuring cycle, copies the values of channel n to the interface buffer and outputs the actual voltage and current. The voltage and current are from the same measuring cycle!!
4c	read:volt:trmsn?↵fetc:curr:trmsn?↵	217.75;0.6135	Waits until the end of the measuring cycle, copies the values to the interface buffer and outputs the actual voltage and current of channel n . The voltage and current are also from the same measuring cycle!!
5a	calc:formU„Bpk=Urect/(4*f*3*0.0000916);↵ Hpk=Ipp/2*3/0.085608;↵ Ua=Bpk/1.2566e-6/Hpk;“↵		Enters the script between the „“ signs. This script is stored in the script editor and executed from the next measuring cycle.
5b	read:var?U(0:1)↵	3.4567,2.8405	Waits until the end of the measuring cycle, copies the values to the interface buffer and outputs the variables 0 to 1 (Bpk and Hpk). Both are from the same measuring cycle!!
6a	fetc:volt:trm3?↵		You misspelled the request
6b	syst:err:all?↵	command header error:TRM3	You ask the error queue what happened and get the answer. If you have misspelled more than this command, you get more answers.
7a	inst:selU1; *opc?↵		Switch to the CE harmonics mode
7b	read:harm:curr:ampln?U(3:5)↵	1.2346,00034,0.9984	Waits until the end of the measuring cycle, copies the values of channel n to the interface buffer and outputs the amplitudes of the current harmonics of order 3 to 5. All are from the same measuring cycle!!
7c	inst:selUnorml; *opc?↵		switch back to the normal measuring mode
8a	trig:act;fetc:volt:trms?;fetc:pow?↵		Defines that the voltage and the power should be output after every measuring cycle, without any further request.

No.	Sent	Received	Comments
8b	init:contUon↵	220.34;15.345 220.19;15.217	Activates this continuous output of the values defined with 'actn'. (until the CONT OFF command!)
8c	init:contUoff↵		stops the continuous output.
9a	mem:freUon		freezes the scope memory
9b	sens:wav:iupd;:sens:wav:ssam?;:sens:wav:sbtr?;:sens:wav:satr?↵	56, -3204, +4506	calculates new information to the sampled values of group B (0 = group A, 1 = group B), reads which values are stored and how much values are stored before and after the trigger
9c	sens:wav:wave?U5, (-100:100)↵	220.45, 221.36 ... (comma separated one dimensioned array with the size 201)	Reads out the sampled values of the voltage
9d	mem:freUoff↵		deactivates the scope memory
10	gtl		Changes from the remote to the local state. So the instrument can be controlled manually

10.2.20 SHORT command Example

This shows you as an example (in SHORT language), what you could send, what the instrument should answer and some comments about this. Some of the responses like measuring values depend on measured signals, so they may be different, if you try this examples. This examples work with a new powered on instrument (no commands before!). For testing some functions we recommend to use the RS232 interface, because it is much more simple to use than the IEEE interface. In principal the example works with both interfaces. This should help you to program your requests and to understand how to communicate with the instrument.

Two comments on the syntax in the 'Sent' column: A 'U' stands for a space character, a '↵' for the <cr> (carriage return) character (which is the enter key, if you use for example a RS232 terminal-program on your PC).

No.	Sent	Received	Comments
1	*rst↵		Reset the instrument to it's default values. After this first command the instrument changes to the remote state.
2	*idn?↵	ZES ZIMMER Electronic Systems GmbH, LMG450, serial number, version	You ask the instrument for it's identification.
3	syst:lang short↵		Switch to the SHORT command set
4a	utrmsn?↵	0	Reads out the voltage of channel n(=1,2,...). You don't get the actual value, because there has been no values copied to the interface buffer

No.	Sent	Received	Comments
4b	inim;utrmsn? ↵	220.34	Waits until the end of the measuring cycle, copies the values of channel n to the interface buffer and outputs the actual voltage
4c	utrmsn? ↵	220.34	No values of channel n were copied to the interface buffer, so you get the same result!
5a	inim;utrmsn?;inim;i trmsn? ↵	220.21;0.6437	Waits until the end of the measuring cycle, copies the values of channel n to the interface buffer and outputs the actual voltage. Then the instrument waits until the end of the next measuring cycle, copies the values to the interface buffer and outputs the actual current. The voltage and current are from different measuring cycles!!
5b	inim;utrmsn?;itrmsn ? ↵	221.13;0.6432	Waits until the end of the measuring cycle, copies the values of channel n to the interface buffer and outputs the actual voltage and current. The voltage and current are from the same measuring cycle!!
5c	inim;utrmsn? ↵ itrmsn? ↵	217.75;0.6135	Waits until the end of the measuring cycle, copies the values of channel n to the interface buffer and outputs the actual voltage and current. The voltage and current are also from the same measuring cycle!!
6a	form␣,,Bpk=Urect/(4*f*3*0.0000916); ↵ Hpk=Ipp/2*3/0.0856 08;↵ Ua=Bpk/1.2566e- 6/Hpk;“↵		Enters the script between the „“ signs. This script is stored in the script editor and executed from the next measuring cycle.
6b	inim;var?␣(0:1)↵	3.4567,2.8405	Waits until the end of the measuring cycle, copies the values to the interface buffer and outputs the variables 0 to 1 (Bpk and Hpk). Both are from the same measuring cycle!!
7a	utrm3? ↵		You misspelled the request
7b	errall? ↵	command header error:UTRM	You ask the error queue what happened and get the answer. If you have misspelled more than this command, you get more answers.
8a	mode␣1; *opc? ↵		Switch to the CE harmonics mode
8b	INIM;HIAM?␣(3:5)↵	1.2346,00034,0.9984	Waits until the end of the measuring cycle, copies the values to the interface buffer and outputs the amplitudes of the current harmonics of order 3 to 5. All are from the same measuring cycle!!

No.	Sent	Received	Comments
8c	mode∪norml; *opc?↵		switch back to the normal measuring mode
9a	actn;utrmsn?;pn?↵		Defines that the voltage and the power of channel n should be output after every measuring cycle, without any further request.
9b	cont∪on↵	220.34;15.345 220.19;15.217	Activates this continuous output of the values defined with 'actn'. (until the CONT OFF command!)
9c	cont∪off↵		stops the continuous output.
10a	frz∪on		freezes the scope memory
10b	sact1;ssam?; sbtr?;satr?↵	56, -3204, +4506	calculates new information to the sampled values of group B (0 = group A, 1 = group B), reads which values are stored and how much values are stored before and after the trigger
10c	wave1?∪5, (- 100:100)↵	220.45, 221.36 ... (comma separated one dimensioned array with the size 201)	Reads out the sampled values of the voltage of channel 1
10d	frz∪off↵		deactivates the scope memory
11	gtl		Changes from remote to the local state. So the instrument can be controlled manually

10.3 Physical devices

The physical devices are the jacks at the rear panel of the instrument.

10.3.1 The serial interfaces

The most simple but universal interface. The LMG450 has build in two of them in the standard instrument.

Both can be used for data logging as well as for remote control. The maximum transfer rate is 115200 Baud. That are about 10000 characters per second. By this you are able to transfer also the very many harmonic values in real time to your PC.

Together with the BMP2PC software (available from our homepage) you can also get screen shots via the serial interface onto your PC.

With the same speed you can also remote control the instrument, send commands and get answers.

10.3.1.1 COM A, RS232

In this female connector a null modem is implemented. That means if you want to connect COM A of the LMG450 to a PC you have to use a cable which connects 1:1 (without a null modem function).

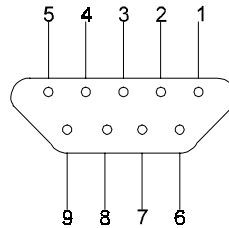

Figure 40: COM A connector

Pin	1	2	3	4	5	6	7	8	9
Comment	nc	TxD	RxD	nc	GND	nc	CTS	RTS	nc

10.3.1.2 COM B, RS232

In this male connector no null modem is implemented. That means if you want to connect COM B of the LMG450 to a PC you have to use a cable with null modem function.

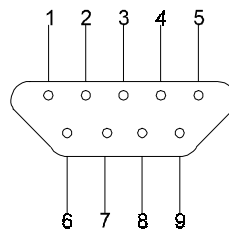

Figure 41: COM B connector

Pin	1	2	3	4	5	6	7	8	9
Comment	DCD	RxD	TxD	DTR	GND	DSR	RTS	CTS	RI

10.3.2 IEEE488.2

This interface is also known as IEC625 bus or GPIB. By it you can implement the LMG into an existing bus system.

The IEEE interface can just be used for remote control, not for logging. The maximum data transfer is about 1 Mbytes per second. This and the connection of several other devices makes this bus a standard for complex measuring systems

This port has the pinout defined in the standard IEEE488. You can use the standard cables.

10.3.3 Parallel Port

Whenever you want to print out data directly, this interface is used. In the LMG we have implemented drivers for the most popular printers. They are just needed, if you want to print out graphics.

Like with the serial interface you can print out cyclic values as tables.

Printers are not the fastest devices, so it can happen, that the printer gets more data than it can handle. In this case the printing is interrupted

This port has the same pinout like a PC parallel port. You can use the same cables.

11 Logging of values to drives, printer and interfaces

All menus you see can be stored to a memory card, floppy disk drives, interfaces or can be printed out. In principal you get what you see. Some exceptions are described in the individual chapters (e.g. you get all harmonics, not only the visible). If you want to record in single mode you get the values you see. That means when you have frozen the display you get the frozen values. If you are in a periodic mode then you get the actual values, also if you have frozen the display.

The data logging is handled in a way that you have to press as few keys as possible to get the result: To output the measured values periodically or one time to an interface or storage media.

There are no menus where you have to choose the values you want to output. Choose just one of the available menus and press *Print/Log*.

You get an dialog box where you can choose the destination of the logging (with **Dest.**). This can be a file, an interface or a printer.

Each single destination entry in this menu describes an output device and its most important setting. For storage media this is the file name, for the printer the printer type and for the interfaces the baud rate. This and other settings you can change at any time by pressing **Set**. Your changes are stored in so called 'profiles'. This profiles are stored in the memory. They are just valid in their environment: If you change the baud rate of ComA for logging, the baud rate of ComA for remote control is not changed!

In the dialog box you see further on the state of the chosen destination device. For storage media you see here also the available size and the number of stored files. For printers you can get 'printer ready', 'printer busy' or 'paper empty'.

11.1 Start of logging

The logging itself starts, if you close the dialog box with *Enter*. (if you press *Esc* you close the box without storing). In the status bar you get at the right side a red/green flashing log display while the logging is active.

If you want to output to a serial interface it could happen, that this interface is already reserved for remote control. In this case you are asked, if you want to change the usage of this interface from remote control to logging. If you say 'Yes' the usage is changed. Please make sure, that you don't have any remote controlled data transfer before you press *Enter*.

11.2 End of logging

To stop an periodic output (one time outputs are stopped automatically) you have to press *Print/Log* again. By pressing *Enter* you stop the logging, with *Esc* you leave the dialog box

11.3 Logging profiles (output devices)

Following profiles are accessible after pressing **Dest.**:

Disk(Data): filename

Writes the data of the actual menu to the file 'filename'. As default this is 'LOG', but you can choose any other name with up to 6 characters. This name is expanded by a two digit number which is incremented with each new logging. The extension is always '.AT'. Some examples for filenames are (the number is generated by the LMG):

LOG00.DAT

LOG01.DAT

MYDAT05.DAT

MOTOR_01.DAT

MOTOR_02.DAT

If you want to know, which files already exist on a media, how much space is available or if you want to setup anything press **Set.**

Here you can choose a new name for the next logging with **File**. By pressing **Mark*** you can mark/unmark files and delete them with **Del***. With **Clear Disk** you format a media.

Typ. lets you choose another output format (see 11.4, 'Output formats')

Caution

Do never remove the media, while a logging is in progress. This can corrupt the files and destroy your measuring results!

Disk(Scr): filename

Saves a screen shot of the displayed menu as a PCX file at the media. All settings are identical to 'Disk(Data)', except the **Typ.** is fixed to 'PCX'.

ComA: baudrate

The measuring values are transferred in the chosen 'Output as' format via ComA with the displayed baud rate. With **Set** you can change baud rate, protocol or the format. For the connection to the PC you have to use a 1:1 cable.

ComB: baudrate

Same like 'ComA: baudrate', but another jack and you have to use a null-modem cable.

ComA: BMP2PC

If you don't have a storage media but want to get screen shots, you can use this profile. Use our program BMP2PC (available on our homepage www.zes.com) and connect your PC with a 1:1 cable with ComA. Then you can transfer a screen shot to the PC and the receiving program stores it as a bitmap file.

Lpt: printer

On a connected printer you can output measuring values as well as hardcopies of the actual screen. The 'output as displayed' is pure text, so that you can connect almost every printer. For a graphical output you have to setup the correct printer type. Due to the growing number of printers it's not possible to write a driver for each type. So we implemented 5 generic drivers which can drive most available printers:

EPSON 9-Pin

EPSON ESP/P

EPSON ESP/P2

HP DeskJet

HP LaserJet

In case of any doubts please contact your local computer shop.

After pressing **Set** you can setup the model (**Prn**) and the output format (**Output as**). Further on you can create a comment (**Rem**) which is also printed (see 11.5, 'Remarks, header lines').

Some models try to get a complete image of a page in their RAM before they start printing. Therefore you might think, the printer is not working, if you send it just some few lines.

It's not a good idea to output a page after just few lines. Therefore we send as default no form feed to the printer. But you can change this with **At end**: instead of 'None' setup 'paper out'. Or you can press **Page out** to do this manually, when you like.

11.3.1 Output intervals

With **Mode** you can setup how often the values should be output:

- every cycle The values are periodically output after each measuring cycle. Please make sure, that the output device is fast enough!
- periodic The values are output after the interval you set up. The minimum time is 10s. After you have chosen 'periodic' you get this time in a highlighted box. If the value is ok, you press just *Enter*. If not press **Per.** and change it. Leave the box with *Enter*.
- every integral The output interval depends on the settings of the *Int. Time* menu. The outputs starts, if you have started an integration. For the different integration modes you get:
- continuous Output at end of measuring cycle
 - interval One time output after the integration time is over.
 - periodic Periodic after each integration time
 - summing Output at end of measuring cycle
- by script The output is done, when the `print ()` function in the script editor is called (see 4.4.4.2.7, 'Functions').

11.4 Output formats

Output as displayed

As default the values are output in the same position like at the display. A one-time output of default menu, 1st channel could look like this:

```
Itrms:1= 0.0270 A
Utrms:1= 0.1414 V
P:1=-0.004 W
Q:1= 0.000 var
S:1= 0.004 VA
PF:1= 0.9992
```

Output as csv (Excel)

At periodic output it is an advantage, if the values are ordered by time. To do this choose the 'csv (Excel)' format.

```
dt/s, Itrms1/A, Utrms1/V, P1/W, Q1/var, S1/VA
216.00E-03, 289.94E-03, 221.61E+00, 41.313E+00, 49.210E+00, 64.253E+00
716.00E-03, 289.51E-03, 221.68E+00, 41.290E+00, 49.132E+00, 64.178E+00
1.2160E+00, 289.64E-03, 221.59E+00, 41.172E+00, 49.234E+00, 64.180E+00
1.7230E+00, 290.86E-03, 221.45E+00, 41.291E+00, 49.435E+00, 64.410E+00
2.2160E+00, 289.72E-03, 221.54E+00, 41.261E+00, 49.164E+00, 64.184E+00
2.7160E+00, 289.95E-03, 221.57E+00, 41.335E+00, 49.181E+00, 64.245E+00
3.2160E+00, 289.21E-03, 221.54E+00, 41.206E+00, 49.065E+00, 64.073E+00
3.7160E+00, 289.75E-03, 221.46E+00, 41.280E+00, 49.126E+00, 64.167E+00
4.2160E+00, 289.83E-03, 221.44E+00, 41.232E+00, 49.181E+00, 64.178E+00
4.7160E+00, 290.01E-03, 221.50E+00, 41.290E+00, 49.210E+00, 64.238E+00
```

5.2160E+00, 289.41E-03, 221.51E+00, 41.262E+00, 49.066E+00, 64.109E+00

The measuring values are written in scientific format without identifier or unit into a table. By this it is very easy to load such data into for example EXCEL. Invalid values are marked as '-----'. Each line ends with <CR><LF>.

The first column is always the time in seconds after the start of the logging. In general this is an integer multiple of the cycle time. In the harmonic and flicker modes you find here the number of signal periods which were used for analysis. So if you know the signal frequency you can calculate the real time (an exception is the Harm100 mode, because here the measuring has to be done with gaps!)

11.5 Remarks, header lines

At the start of each output (floppy disk, memory card, printer, ...) you can place several comment/header lines. When logging periodically, this header lines are just printed at the start of logging.

When editing this field (see 11.3, 'Logging profiles (output devices)') you can use a pre defined example with **Exmp**. You can modify and delete this example by **Edit**. If you have finished, press **End**.

You can see standard text and some special identifiers with a leading '\$'. They will be replaced when logging the header by their real value. In the case of '\$Cycle' the real cycle time will be inserted at this position. You can select every identifier. For a list of this identifiers please refer chapter 10.2, 'Commands'. The 'ID' field specifies the useable values. They are the same identifiers like for the script editor.

If you log the *Default* menu with the example header you get following result:

```
My Company
Printed at 22.04.2003 14:22:13
Cycletime 500.00 ms
Voltage at channel 2: 136.99mV
```

```
Itrms:1  0.0320 A
Utrms:1  212.01 V
P:1      -0.14 W
Q:1      6.78 var
S:1      6.78 VA
PF:1     20.646 m
```

Like in the script editor you can call the pre-defined lists (see chapter 4.5, 'Entering identifiers, characters and text'). Just remember to use the '\$' in front of the identifier.

When „Output as table“ in front of each comment line a 'REM' is written to simplify evaluation.

11.6 Storage media

Storage media are used to store single or periodic measuring data. The data format is equal to the data format of the serial or parallel interface. But this data are written immediately and evaluated later on.

Equivalent to a screen dump to a printer you can make a screen shot and store it in the popular PCX file format.

The LMG450 can have either a memory card drive or a floppy disk drive

11.6.1 Floppy disk drive

The optional floppy disk drive is a PC compatible 3 1/2" drive for 1.44 Mbytes disks.

The file format is MSDOS (FAT) format. So you can read it with each PC with an Microsoft OS.

Floppy disk is a very good medium for data transfer to a PC if you want to evaluate the measured data afterwards. The disadvantage is the slow data transfer and the medium storage capacity. The medium transfer rate is just about 20kbyte per second, if you use a blank, formatted disk.

If you want to store harmonic values you get about 100 harmonics for 4 channels for each measuring cycle. That are 400 values which take about 5000 characters in storage. At 200ms cycle time you have about 25kbyte per second! In this case it might be better to use a memory card drive.

11.6.2 Memory card drive

Also the memory card drives use the MSDOS (FAT) format. But they are much faster. And you can get memory cards with several Mbytes capacity.

A big advantage of memory cards is the immunity against electromagnetic distortions.

If you have a laptop with PCMCIA card (equal to PC card) drive you can read the memory card directly. For other PCs you can use external drives

11.6.2.1 Reading memory cards with a laptop

The used memory cards are SRAM cards according to the PCCard standard (identical to PCMCIA). On some laptops the memory card reader has to be configured first, to read memory cards. Please ask your computer supplier for details and check the user manual of the memory card reader.

A general description for WIN95/98

Open the file Config.sys with an editor and add the following two lines at the end:

```
device=c:\windows\system\csmapper.sys  
device=c:\windows\system\carddrv.exe /slot=n
```

n means the number of PCCard slots of the laptop. Check that both files csmapper.sys and carddrv.exe exist in the c:\windows\system directory.

Now restart the laptop with fitted memory card. The Windows Explorer will show the SRAM card as a separate drive.

11.6.3 USB memory stick

The number of files and directories in the root directory must not be more than 150. Else you get the error message „File Table Overflow“.

The stick must be formatted with FAT16. FAT32 will not work! The stick must not contain any own operating system (like e.g. Titanium Cruzer). Such an OS must be removed before the usage. The stick must not have more than one partition.

After calling the log dialog it can take several seconds until the structure of the memory stick is analysed. The time increases, if more files or stored on the stick. If the log dialog is opened, the stick must not be removed.

The stick implementation does not support a real formatting of the stick. So if you choose formatting, only the files in the root directory are delete. This can take several seconds. For a real formatting, please use a PC.

11.7 Import of data into PC programs

To get the measuring values into your PC you have two possibilities: You can store them on a storage media or you can send them via the serial interface.

11.7.1 Data exchange via storage media

If you are using a floppy disk it is no problem if you have a standard floppy disk drive. For the memory card you need a laptop with a free PCMCIA (PC-Card) slot or an external card reader. ZES also offers such card readers.

11.7.2 Data exchange via serial interface

For this you just need a 1:1 cable (or a null modem cable if you are using ComB) and an installed terminal program. On each Windows PC you should have the program 'Hyperterm' already installed.

1. Start Hyperterm and enter any name for the new connection.
2. Choose the COM port which is connected to your PC.
3. Set up this port with following parameters:

Baud rate	115200
Databits	8
Parity	None
Stopbits	1
Protocol	None
4. Hyperterm is now ready to receive data. To test the connection press *Print/Log* at LMG, choose 'ComA: 115200' as destination. If the baud rate should not be 115200 please set it via **Set**. If you are using ComB do the same for it.
The mode should be set to 'one-time' and 'output as table'.
5. Press *Enter* to start the transfer.
6. Hyperterm should now display the values. If not, check the correct ports, cable and all settings. Check also that Hyperterm is 'on-line'. If not, open the connection.
7. Hyperterm receives correct data. You can save the following data into a file via menu 'transfer' and 'save text'
8. Press at LMG *Print/Log* again and choose now 'every cycle'. Start logging with *Enter*.
In Hyperterm you see now the received data which are stored in background.
9. To stop the logging press *Print/Log* and *Enter*.
10. Stop the recording of Hyperterm by closing the text file. If you open this file with any text editor you see the logged data.

11.7.3 Country dependent numbers

Float numbers are output with a dot '.' as decimal separator. This can cause problems, when your computer is set up to use ',' as separator (like for example in Germany). In this case set up your operating system to use the dot '.' as separator.

11.7.4 Reading data into EXCEL

First make sure, that the decimal separator is set up correctly. Then start Excel and load the file. Choose the number of lines Excel should skip to reject the header.

As column separator select a space.

Now the data from the file are read into Excel without any problems.

11.8 Error messages

Drive not ready

You have chosen a storage media as destination, but this media is not plugged in. Press *Esc* until the message vanishes. Choose another destination or insert the storage media

Operation not permitted

An error occurred while storing. For example the storage media was removed.

Output device too slow - stopped!

The chosen output device is too slow to handle the data in real time. In this case the logging is stopped. Press *Esc* until the message vanishes. Choose a faster output device or reduce the data volume for example by choosing a longer cycle time.

All values until this message are stored correctly.

12 Miscellaneous

12.1 Frequently asked questions

12.1.1 Uncertainty of measured and computed values

The uncertainty of the directly measured values I, U and P can be found in the tables in 13.3.3, 'Uncertainty'. The following calculations illustrate how to use these tables and how to calculate the uncertainty for other values.

The read value of device should be:

$U_{\text{rms}}=230.000\text{V}$, range 250V, peak range 400V

$I_{\text{rms}}=0.95000\text{A}$, range 1.2A, peak range 3.75A

$\lambda=0.25000$

$f=50.0000\text{Hz}$

$P=54.625\text{W}$, range 300W, peak range 1500W

AC coupling mode for the signal

From the table for the general uncertainties, the following uncertainties for voltage and current can be determined (using the peak values of the respective measuring range):

$$\Delta U = \pm(0.05\% \text{ of } R_{\text{dg.}} + 0.05\% \text{ of } R_{\text{ng.}}) = \pm(0.115\text{V} + 0.02\text{V}) = \pm 0.315\text{V}$$

$$\Delta I = \pm(0.05\% \text{ of } R_{\text{dg.}} + 0.05\% \text{ of } R_{\text{ng.}}) = \pm(0.475\text{mA} + 1.875\text{mA}) = \pm 2.35\text{mA}$$

$$\Delta P = \pm(0.07\% \text{ of } R_{\text{dg.}} + 0.04\% \text{ of } R_{\text{ng.}}) = \pm(38.24\text{mW} + 600\text{mW}) = \pm 0.638\text{W}$$

Why to use the peak value of a measuring range and not any nominal values?

Analogue instruments use the DC or RMS component of a signal for displaying the true value. Due to some analogue characteristic of their working principle (saturation, non linearities of components, ...) it could happen, that a signal with a small RMS component but a big peak value was disturbed. So these instruments had to specify a maximum allowed crest factor (the ratio of peak value to rms value) for which they could guarantee a reading inside their specifications. But there was no really hard limit for the maximum measurable peak value. The "range" to use for uncertainty calculations was the RMS range for sinusoidal signals.

But the world has changed: Signals become more and more disturbed and modern instruments like this LMG use AD converters. The range is now defined as the biggest

value an ADC can sample, the RMS can be as big as this biggest value (in case of DC) or also very much smaller (for example in case of an inrush current). For this reason the only range value for an uncertainty calculation which could be legitimated physically is the peak value (= the range of the ADC). The RMS value (as well as the not further necessary crest factor) can be defined randomly: A 100Vpk range can be specified as 70Vrms range with crest factor 1.43 or as 5Vrms range with crest factor 20. In other words: It makes sense to specify the crest factor of a signal (to choose the correct peak range) but it is pointless to specify a crest factor for a modern digital instrument. What is the physical information?? Important is, that the peak value is not bigger than the ADC range!

Physically it makes absolutely no sense to specify a RMS range for uncertainty calculations for modern instruments with ADC sampling. That is the reason why ZES ZIMMER uses the physically correct peak value of a range, because this is the true range of the ADC!

The power factor is computed as follows:

$$\lambda = \frac{P}{S} = \frac{P}{U * I}$$

The uncertainty for power factor is calculated corresponding to the rules of uncertainty computation using the total differential:

$$\Delta\lambda = \frac{\partial\lambda}{\partial P} * \Delta P + \frac{\partial\lambda}{\partial U} * \Delta U + \frac{\partial\lambda}{\partial I} * \Delta I$$

$$\Delta\lambda = \frac{\Delta P}{U * I} - \frac{P * \Delta U}{I * U^2} - \frac{P * \Delta I}{I^2 * U}$$

$$\Delta\lambda = \frac{0.638mW}{230V * 0.95A} - \frac{54.625W * 0.315V}{0.95A * (230V)^2} - \frac{54.625W * 2.35mA}{(0.95A)^2 * 230V}$$

$$\Delta\lambda = 0.0020$$

This is the maximum uncertainty (worst case) that can occur in the calculation of the power factor. The typical uncertainty is two to five times better!

The relative measuring uncertainties are:

$$U \%_{measure} = \frac{\Delta U}{U} = 0.137\%$$

$$I \%_{measure} = \frac{\Delta I}{I} = 0.247\%$$

$$P \%_{measure} = \frac{\Delta P}{P} = 1.16\%$$

$$\lambda \%_{measure} = \frac{\Delta \lambda}{\lambda} = 0.78\%$$

To get the real uncertainty, the uncertainty of display (1 digit) has to be taken into account:

$$U \%_{display} = \frac{0.01V}{230.0V} = 0.004\%$$

$$I \%_{display} = \frac{0.0001A}{0.95A} = 0.01\%$$

$$P \%_{display} = \frac{0.01W}{54.625W} = 0.02\%$$

$$\lambda \%_{display} = \frac{0.0001}{0.25} = 0.04\%$$

This results in the following measuring values:

$$U_{trms} = (230.00 \pm 0.32)V$$

$$I_{trms} = (0.9500 \pm 0.0024)A$$

$$P = (54.625 \pm 0.638)W$$

$$l = 0.2500 \pm 0.0020$$

When using the AC+DC coupling instead of the AC coupling, you get different uncertainties.

In this case you might get an additional DC current of $\Delta I_{DC} = \pm 5mA$.

This uncertainty influences the TRMS value in the following way:

$$I_{trms} = \sqrt{I_{ac}^2 + I_{dc}^2}$$

$$\Delta I_{trms} = \pm \left(\frac{\partial I_{trms}}{\partial I_{ac}} * \Delta I_{ac} + \frac{\partial I_{trms}}{\partial I_{dc}} * \Delta I_{dc} \right)$$

$$\Delta I_{trms} = \pm \left(\frac{I_{ac}}{I_{trms}} * \Delta I_{ac} + \frac{I_{dc}}{I_{trms}} * \Delta I_{dc} \right)$$

With an reading of $I_{dc} = 0.00112A$ you get:

$$\Delta I_{trms} = \pm \left(\frac{0.95A}{0.95A} * 2.35mA + \frac{1.12mA}{0.95A} * 5mA \right) = \pm 2.3559mA$$

For the active power you have an additional uncertainty of $\pm 5 \text{ mW/V}_{\text{dc}}$. So with a reading of $U_{\text{DC}}=0.013 \text{ V}$ you get a total uncertainty of

$$\Delta P_{\text{tot}} = \pm \left(\Delta P + 5 \frac{\text{mW}}{\text{V}} * U_{\text{DC}} \right) = \pm \left(0.638 \text{ W} + 5 \frac{\text{mW}}{\text{V}} * 13 \text{ mV} \right) = \pm 0.638065 \text{ W}$$

For the apparent power you get:

$$\Delta S = \pm \left(\frac{\partial S}{\partial U} * \Delta U + \frac{\partial S}{\partial I} * \Delta I \right)$$

$$\Delta S = \pm (I * \Delta U + U * \Delta I) = \pm (0.95 \text{ A} * 0.315 \text{ V} + 230 \text{ V} * 2.35 \text{ mA}) = \pm 0.83975 \text{ VA}$$

Please note that in this case you have to use ΔI_{rms} for ΔI !

If you use external sensors please see the ZES Sensors and Accessories Manual for hints, how to calculate the total uncertainty under this circumstances.

12.1.2 Uncertainty of non sinusoidal signals

The standard uncertainties are just given for sinusoidal signals. The reason is, that the national standards usually work just with sinusoidal signals.

To estimate the uncertainty of non sinusoidal signals you can use the following system.

Let's assume you want to measure a square signal with 5V peak value, 50% duty cycle, no DC value and a frequency of 100Hz.

First the signal has to be divided into its frequency components. Then the uncertainties of the rms-values of each frequency component have to be calculated. The used uncertainty is the standard uncertainty of reading at the specific frequency according to the technical specification. All these uncertainties have to be added geometrically (because they are rms values with different frequencies). Further on you have to add the uncertainties of the measuring range at the frequency with the biggest amplitude (usually the fundamental) once (once because it includes common uncertainties like offset, ...). With this sum you can calculate the total uncertainty.

The values in the columns of the following table are:

Frequency (f / Hz)

rms value at this frequency (U / V)

Percentage uncertainty of frequency component according to technical data (% of value)

- Absolute uncertainty of frequency component (ΔU / mV)

f / Hz	U / V	Uncertainty in % of U	Uncertainty ΔU / mV
100	4.501	0.1	4.501

f / Hz	U / V	Uncertainty in % of U	Uncertainty ΔU / mV
300	1.500	0.1	1.500
500	0.900	0.1	0.900
700	0.636	0.1	0.636
900	0.499	0.1	0.499
1100	0.408	0.2	0.816
1300	0.346	0.2	0.692
1500	0.300	0.2	0.600

For this example only the harmonics from 1 (100Hz) to 15 (1500Hz) have been used. Harmonics of a higher order cause just barely greater uncertainties not affecting the total uncertainty very much like shown in the table.

The geometrical sum of all uncertainties results in an error of 5.05mV.

To that you have to add the uncertainty of the range (0.1% of 12.5V (peak-value) = 12.5mV).

The total uncertainty is 17.55mV which is 0.35% of 5V.

12.2 Function fault

If you think you have found an error or function fault in a LMG450 please fill out the following page and send it to ZES. If you think the measuring result are wrong, please also fill out the second page. For this purpose connect the measuring circuit, freeze the screen with the values and fill out the paper with the frozen values.

On the attached CD you find a tool called 'LMG CONTROL'. One feature of this tool is, that it can store all measuring values and a complete configuration in a report file. You can also use this tool to generate a function fault report.

Measuring menu**Globals**

Cycle: _____ Aver: _____ Wiring: _____

Group A

Filter: _____ S_Cpl: _____
Couple: _____ Sync: _____

Group B

Filter: _____ S_Cpl: _____
Couple: _____ Sync: _____

Channel 1**Range menu**

U range: _____ V I range: _____ A
U range: auto/manual I range: auto/manual
U scale: _____ I scale: _____
Sensor: intern/extern Sensor-Typ, SN: _____

Voltage menu

Utrms: _____
Uac: _____
Udc: _____
Upp: _____
Upkp: _____
Upkn: _____
Urect: _____
Ucf: _____
Uff: _____

Current menu

Itrms: _____
Iac: _____
Idc: _____
Ipp: _____
Ipkp: _____
Ipkn: _____
Irect: _____
Icf: _____
Iff: _____
Iinr: _____

Power menu

P: _____
Q: _____
S: _____
PF: _____
f: _____
Z: _____
Rser: _____
Xser: _____

Channel 2**Range menu**

U range: _____ V I range: _____ A
U range: auto/manual I range: auto/manual
U scale: _____ I scale: _____
Sensor: intern/extern Sensor-Typ, SN: _____

Voltage menu

Utrms: _____
Uac: _____
Udc: _____

Current menu

Itrms: _____
Iac: _____
Idc: _____

Power menu

P: _____
Q: _____
S: _____

Upp: _____	Ipp: _____	PF: _____
Upkp: _____	Ipkp: _____	f: _____
Upkn: _____	Ipkn: _____	Z: _____
Urect: _____	Irect: _____	Rser: _____
Ucf: _____	Icf: _____	Xser: _____
Uff: _____	Iff: _____	
	Iinr: _____	

Channel 3

Range menu

U range: _____V	I range: _____A
U range: auto/manual	I range: auto/manual
U scale: _____	I scale: _____
Sensor: intern/extern	Sensor-Typ, SN: _____

Voltage menu

Utrms: _____
 Uac: _____
 Udc: _____
 Upp: _____
 Upkp: _____
 Upkn: _____
 Urect: _____
 Ucf: _____
 Uff: _____

Current menu

Itrms: _____
 Iac: _____
 Idc: _____
 Ipp: _____
 Ipkp: _____
 Ipkn: _____
 Irect: _____
 Icf: _____
 Iff: _____
 Iinr: _____

Power menu

P: _____
 Q: _____
 S: _____
 PF: _____
 f: _____
 Z: _____
 Rser: _____
 Xser: _____

Channel 4

Range menu

U range: _____V	I range: _____A
U range: auto/manual	I range: auto/manual
U scale: _____	I scale: _____
Sensor: intern/extern	Sensor-Typ, SN: _____

Voltage menu

Utrms: _____
 Uac: _____
 Udc: _____
 Upp: _____
 Upkp: _____
 Upkn: _____
 Urect: _____
 Ucf: _____
 Uff: _____

Current menu

Itrms: _____
 Iac: _____
 Idc: _____
 Ipp: _____
 Ipkp: _____
 Ipkn: _____
 Irect: _____
 Icf: _____
 Iff: _____
 Iinr: _____

Power menu

P: _____
 Q: _____
 S: _____
 PF: _____
 f: _____
 Z: _____
 Rser: _____
 Xser: _____

You can directly print out this menus.

Please sketch also the wiring of LMG450 and equipment under test / measuring signals:

12.3 Maintenance

12.3.1 Calibration

With this precision power meter you have a high end measuring instrument. But you can only take advantage of its performance, if the instrument is well adjusted and calibrated. Especially with the calibration of third party labs there are very often unnecessary problems. If you let the calibration made by any third party calibration lab, please watch following points:

- The reference instruments might have not the required uncertainty, especially for active AC power.
A very common error is, that reference sources, which some companies call 'calibrator' have not the necessary uncertainty to calibrate this instrument. The calibrators are very useful for many hand held multimeters, but are often worthless when calibrating active power. A common candidate for this error is the Fluke 5500A calibrator.
Please keep in mind, that the reference instrument should be at least 3 times more accurate than the device under test. If not, the precision power meter calibrates the so called calibrator!
- The reference instrument may be traceable for voltage and current, but it is very rare, that it is traceable for active AC power with the required uncertainty. Nevertheless it is common, that calibration labs calibrate active power if only voltage and current are traceable. This happens very often in the context of national calibration services like DKD, UKAS, ...
Here it happens regular, that voltage and current are accredited, but not the active power. So this protocols are worthless for active power!

If a calibration is performed by any third party lab, at least following points should be calibrated to ensure a proper function of the instrument:

- Voltage and current of all ranges at a frequency near to 50Hz.
- A representative selection of voltage/current range combinations to ensure a proper power reading

The ZES ZIMMER calibration service offers a traceable calibration of all relevant parameters and meets the requirements of IEC17025. Our active power calibration is directly traceable to PTB (Physikalisch Technische Bundesanstalt in Braunschweig).

A further advantage of our calibration service is, that for the case of a service there are no additional shipping costs and time delays.

12.3.1.1 Requirements for reference instruments

As generally known the references, calibration sources and/or reference power meters, have to be in an uncertainty class, which is at least 3 time better than the instrument. An optimal value is from 5 to 10 times better.

For the allowed uncertainty of the LMG to be calibrated please refer also to chapter 12.1.1, 'Uncertainty of measured and computed values'

12.3.2 Adjustment

The adjustment has to be done at $(23\pm 1)^{\circ}\text{C}$.

ZES ZIMMER offers in principle a way to adjust the instruments outside our factory, if some technical preconditions are fulfilled. For further information, please contact sales@zes.com

12.3.3 Zero adjustment of the instrument

The zero settings of the LMG450 can be adjusted without sending the instrument back to the factory. For this purpose remove **ALL** relevant measuring cables from the instrument and switch to the normal measuring mode. Now short circuit the voltage input (U* and U). Short circuit means, not to connect the inputs with any wire but to connect them as short as possible to get a minimised loop area!

If you want to adjust external sensors connect them, switch to external sensors in the range menu and don't enclose any measuring lead with the sensor.

Warm the instrument up for a minimum of 2h.

Now press **Z-Adj-UChn** resp. **Z-Adj-ICHn** in the *Misc.* menu (see 4.4.1, 'Misc.').

Answer the warning with *Enter* if you have setup the instrument correctly. After about 1 minute the instrument is adjusted and a message appears.

If you are in doubt about any detail of this adjustment please contact the manufacturer.

This adjustment is active, while the instrument is switched on. If you switch off and on the instrument, the factory values are loaded.

12.3.4 Fans

The air filter of the fan near the power supply socket has to be cleaned (depending on the environment two times per year). To do this remove the shield of the fan. When doing this you should check the correct working of this fan.

12.3.5 Battery

In the instrument is a lithium battery for holding several data. It should be checked after 8 years or when any problems occur. In some instruments the battery is plugged, so it can be exchanged very easy. In other instruments it is soldered, so here it is recommended to exchange the battery in our service department.

12.3.6 Software update

The software of the LMG450 can be updated by the customer. You get the actual software from our homepage <http://www.zes.com> or directly by ZES. You need a PC and a serial cable to connect COM1 of your PC to COM A of the LMG450. It has to be a 1:1 cable without any crossings or null modem functions, where all wires are connected.

If you start the update software on your PC you will get detailed information how to handle.

12.4 Use with an inverter

The power meters of the e LMG series accord to the protection class 1. A use without an earthed protective conductor is not permitted. Inverters (e.g. 12Vdc to 230Vac) mostly have no protective conductor. In this case the LMG has to be wired with a protective conductor at the rear panel. Refer the safety rules of the working area.

13 Technical data

13.1 General

Display:	Colour display, resolution 320x240 Pixel
Mains supply:	85...264V, 47...440Hz, ca. 45W, 2 fuses 5x20mm T 1A 250V IEC60127-2 Sheet 3
Storage temperature:	-20°C to +50°C
Safety:	EN61010-1, date according to the declaration of conformity. Normal environmental condition: Indoor use, altitude up to 2000m, temperature 5°C to 40°C, maximum relative humidity 80% for temperatures up to 31°C decreasing linearly to 50% relative humidity at 40°C Mains supply: Measurement category CAT II, pollution degree 2 Measuring inputs: Measurement category CAT III, pollution degree 2 IP20 according EN60529
EMC:	EN61326-1 EN61000-3-2 EN61000-3-3 Dates according to the declaration of conformity.
Dimensions:	Desktop: 320mm (W) x 148mm (H) x 307mm (D) 19" rack: 63DU x 3HU x 360mm
Weight:	7.5kg

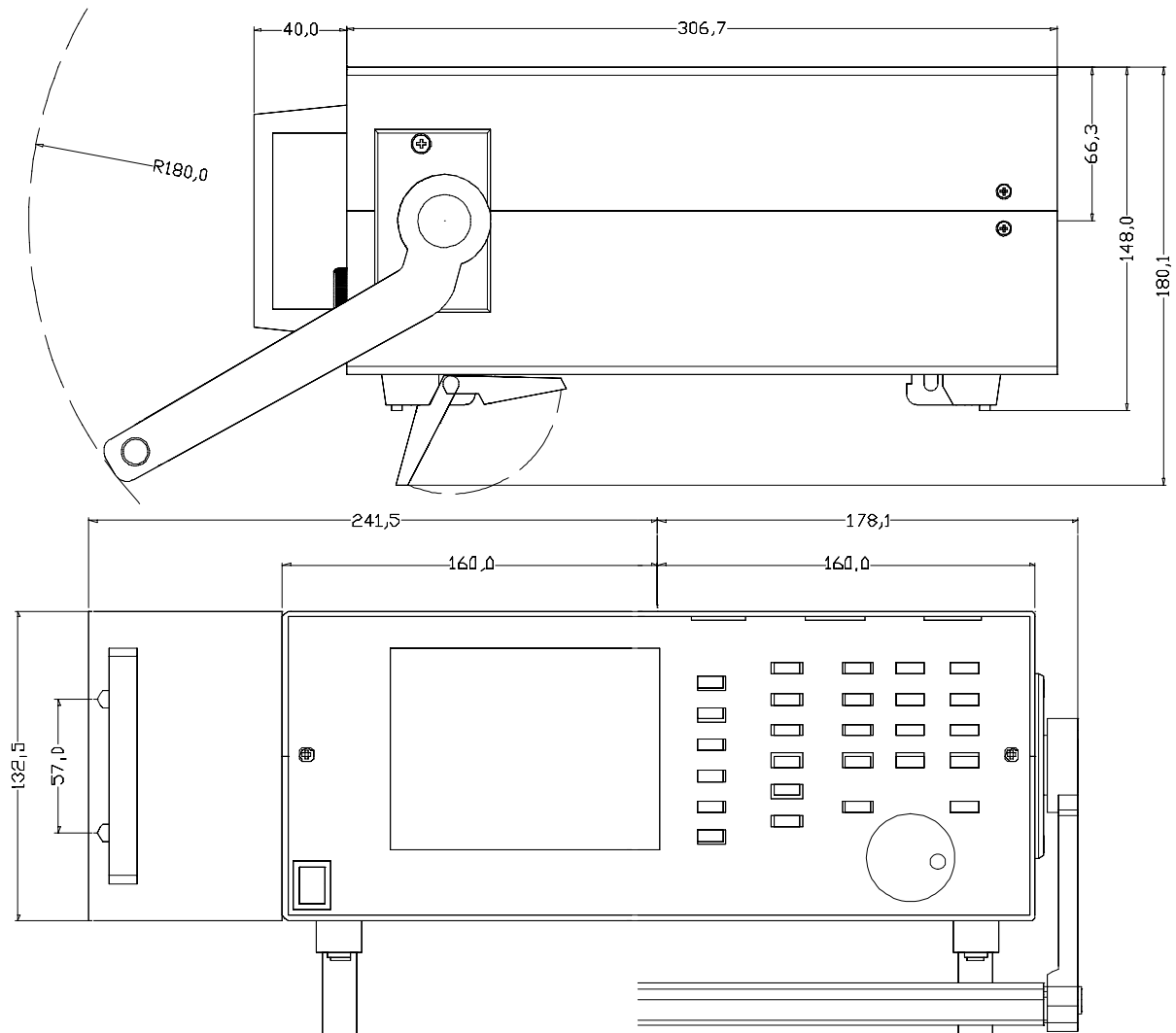

Figure 42: Dimensions of LMG450

In the above picture you see the desktop instrument in combination with the rack mounting kit and the handle bar.

13.2 Display of values

The measured values are displayed with 5 digits. The position of the decimal point is set to the position which is required to display the maximum allowed TRMS value.

If the TRMS value of a measuring channel is lower than 1.5% of the measurable TRMS value of the range, all channel values are displayed as 0.0. For example in the 0.6A current range you get values from 19.500mA...1.875A and 0.000A. This zero rejection can be switched off, see 4.4.1, 'Misc.'

13.3 Measuring channels

13.3.1 Sampling

The sampling is done at all channels with about 50kHz per channel.

13.3.2 Ranges

Voltage ranges

Rated range value / V	6	12.5	25	60	130	250	400	600
Measurable TRMS value / V	7.2	14.4	30	60	130	270	560	720
Permissible peak value / V	12.5	25	50	100	200	400	800	1600

Overload capability 600V continuously, 1500V for 1s

Input resistance 1M Ω , 10pF

Capacitance against earth 280pF

Common mode error (measured with 100V common mode signal at different frequencies in the 6V range without HF-Rejection filter):

50Hz 0V

5kHz <0.01V

10kHz <0.02V

20kHz <0.05V

100kHz <0.12V

Common mode error (measured with 100V common mode signal at different frequencies in the 6V range with HF-Rejection filter):

50Hz 0V

5kHz <0.01V

10kHz <0.02V

20kHz <0.01V

100kHz 0V



Note!

The 'Measurable TRMS value' is the biggest TRMS value which can be measured. That does not mean that it is allowed to measure with that value, if any security standards define other values!

Current ranges

Rated range value / A	0.6	1.2	2.5	5	10	16
Measurable TRMS value / A	1.3	2.6	5.2	10	18	18
Permissible peak value / A	1.875	3.75	7.5	15	30	60

Overload capability 18A continuously, 50A for 1s, 150A for 20ms

Input resistance Ri 2m Ω

Capacitance against earth 10pF

Common mode error (measured with 100V common mode signal at different frequencies in any range without HF-Rejection filter):

50Hz	0mA
5kHz	<0.5mA
10kHz	<1.1mA
20kHz	<2.4mA
100kHz	<8.0mA

Common mode error (measured with 100V common mode signal at different frequencies in any range with HF-Rejection filter):

50Hz	0mA
5kHz	<0.2mA
10kHz	<0.9mA
20kHz	<0.6mA
100kHz	0mA

Channel separation

Capacitance between U and I 10pF

Connecting 100V common mode signal at different frequencies to a voltage channel will cause following errors in the adjoining current channels (without HF-Rejection filter):

10kHz	0mA
20kHz	<0.6mA
100kHz	<2.0mA

Connecting 100V common mode signal at different frequencies to a voltage channel will cause following errors in the adjoining current channels (with HF-Rejection filter):

10kHz	0mA
20kHz	0mA
100kHz	0mA

Connecting 100V common mode signal at different frequencies to a current channel will cause following errors in the adjoining voltage channels (without HF-Rejection filter):

10kHz	<0.4mV
20kHz	<1.0mV
100kHz	<1.3mV

Connecting 100V common mode signal at different frequencies to a current channel will cause following errors in the adjoining voltage channels (with HF-Rejection filter):

10kHz	<0.4mV
-------	--------

20kHz 0mV

100kHz 0mV

Voltage inputs for current measuring with isolating current sensors

Rated range value / V	0.12	0.25	0.5	1	2	4
Measurable TRMS value / V	0.15	0.3	0.6	1.2	2.5	5
Permissible peak value / V	0.25	0.5	1	2	4	8

Overload capability 100V continuously, 250V for 1s

Input resistance 100k Ω , 10pF

Common mode error no error per definition, because this input is not isolated from chassis ground, so you can't apply a common mode signal.

13.3.3 Uncertainty

An example, how to handle this values, you find in 12.1.1, 'Uncertainty of measured and computed values'

Measuring uncertainty

The values are in \pm (% of measuring value + % of measuring range)

Frequency/Hz	DC	1Hz-1kHz	1kHz-5kHz	5kHz-20kHz
Voltage	0.2+0.2	0.1+0.1	0.2+0.2	0.3+0.4
Current via direct input	0.4+0.4	0.15+0.1	0.2+0.2	0.5+0.5
Active Power via direct input	0.5+0.5	0.2+0.1	0.3+0.2	0.6+0.5
Current via voltage input	0.2+0.2	0.1+0.1	0.2+0.2	0.3+0.4
Active power via voltage input	0.3+0.3	0.15+0.1	0.3+0.2	0.6+0.5

Just for AC Coupling

Frequency/Hz	45...65Hz
Voltage	0.05+0.05
Current via direct input	0.05+0.05
Active Power via direct input	0.07+0.04
Current via voltage input	0.05+0.05
Active power via voltage input	0.07+0.07

With DC coupling you have to use the first table!

Uncertainties base on:

1. sinusoidal voltages and currents
2. ambient temperature (23 \pm 3) $^{\circ}$ C, no additional heating or cooling (i.e. by sunlight or current of air)
3. warm up time 1h

4. power range is the product of current and voltage range, $0 \leq |\lambda| \leq 1$
5. Voltage and current are $\geq 10\%$ and $\leq 110\%$ of rated range
6. calibration interval 1 year
7. Adjustment was done at 23°C.

Temperature effect: 0.02% of measuring value / K
 1.5mA/K DC drift

Influence of coupling mode

Coupling AC: No influence

Coupling AC+DC, DC: Current: additional DC current of up to $\pm(5\text{mA})$
 Active Power: additional DC uncertainty of $\pm(5\text{mAV}^2/U_{\text{DC}})$

13.3.4 Special transformer adjustment (L45-O12)

This option improves the uncertainty of active power measuring under following circumstances:

1. AC coupling
2. 45...65Hz
3. PF>0.01

The uncertainty under this condition is $\pm (0.07\%$ of reading + 0.02% of range). All other conditions from the last chapter are still valid.

With this option the phase uncertainty between voltage and current channel is $<0.012^\circ$ at 50Hz. Without this option the phase uncertainty is $<0.046^\circ$.

13.3.5 Modified voltage channel for 1kV input (L45-O15)

With this option, the maximum allowed rms value of the voltage is 1000V. The exact specification is as follows:

Rated range value / V	6	12.5	25	60	130	250	400	1000
Measurable TRMS value / V	7.2	14.4	30	60	130	270	560	999.9
Permissible peak value / V	12.5	25	50	100	200	400	800	1600

Max. voltage U* vs. U and PE: 1000V working voltage, 1600V peak value of the working voltage, 1000V transient over-voltages

Max. voltage U vs. PE: 600V/CAT III

13.4 ZES current sensors

Most ZES sensors have an EEPROM implemented in which we have stored the name, scaling, ranges, adjustment and delay time of the sensor. The LMG500 recognises automatically, which ZES sensor is connected and sets up the range menu. Further on we correct some of the errors the sensor produces (transfer error, delay time, ...). So you get the best measuring results with each sensor.

Due to the EEPROM this sensors offer a plug & play solution for your measuring. The usage of the LMG sensor input offers several measuring ranges which increase the dynamic of the connected sensors.

There is a very wide range of sensors available:

- Current clamps, transformers, hall sensors, flux compensated types, flexible Rogowski sensors, shunts, ...
- Uncertainties up to <0.01%
- Frequency range from DC to several hundred kHz
- Current range from <<1A up to several kA

For the exact specifications of all this sensors you find a detailed manual on the CD which is delivered together with this manual. If this CD is missing or you have this manual only as PDF file you can request it via email from 'sales@zes.com'.

For hints how to connect several sensors to one channel, please refer to chapter 14.1.2.1, 'Several external sensors in a test bench'.

13.5 Filter

13.5.1 HF Rejection filter

The analogue filter has the following characteristic:

Frequency / Hz	Rejection / dB
10	0.0019
20	0.0005
50	0
100	-0.0004
200	-0.0014
500	-0.0086
1000	-0.0319
2000	-0.1459
5000	-0.8350
10000	-3.16

Frequency / Hz	Rejection / dB
20000	-14.45
50000	-49.45

13.6 prCE Harmonics

Relative deviation between f_1 and frequency f_{syn} , to which the sampling rate is synchronised is <0.015% of f_1 under steady-state conditions.

Uncertainty

According EN61000-4-7 Ed. 2.0:

$$\begin{aligned} \text{U: } U_m \geq 1\% U_{\text{nom}}: & \pm 5\% U_m \\ U_m < 1\% U_{\text{nom}}: & \pm 0.05\% U_{\text{nom}} \end{aligned}$$

$$\begin{aligned} \text{I: } I_m \geq 3\% I_{\text{nom}}: & \pm 5\% I_m \\ I_m < 3\% I_{\text{nom}}: & \pm 0.15\% I_{\text{nom}} \end{aligned}$$

With

m = measuring value

$_{\text{nom}}$ = nominal value of the range

Please note

The influence of the HF-Rejection filter is compensated for the amplitudes of the harmonics. The values for U, I and P are not recalculated from the harmonics, but are calculated from the sampling values to get for example interharmonics and components with higher frequencies which are not captured by the harmonics. So it is not possible to compensate the influence of the filters for this values! For the same reason this values can also be much bigger than the values which can be derived from the harmonics (depending on the signal).

13.7 CE Flicker

According to EN61000-4-15:2011 resp. IEC61000-4-15:2010 this is a class F1 flickermeter.

Uncertainty

Flickermeter: $\pm 5\%$ according to EN61000-4-15, $0.3 < k < 5.4$

d-meter: $\pm 0.15\%$ of nominal voltage according to EN61000-3-3

13.8 HARM100 Mode

Amplitude uncertainty

The uncertainty of the harmonic with the biggest amount H_{\max} (usually the fundamental) and of the DC part (H_{00}) is calculated as if each part is measured alone (refer uncertainty specifications of the normal measuring mode).

The uncertainties of the harmonics (H_{01}, H_{02}, \dots) except H_{\max} is calculated as follows:

$$\pm(0.5 * \text{uncertainty}_{H_{\max}} + 0.02\% \text{ from } H_{\max}/\text{kHz})$$

This uncertainty are valid if the amplitude of the harmonics are higher than 0.1% of the full scale peak value.

Example: You have a typical spectrum with the biggest harmonic being the 60Hz fundamental with 1A. You have a 11th harmonic with 0.1A. This spectrum is measured in the 1.2A range. The uncertainty of the fundamental is 0.05% of 1A + 0.05% of 3.75A = 2.375mA.

For the 11th harmonic you have to calculate the uncertainty liek this: $0.5 * 2.375\text{mA} + 0.02\%$ of $1\text{A} * 0.66 = 1.32\text{mA}$.

The 0.66 are $11 * 60\text{Hz} = 660\text{Hz}$ relative to 1kHz.

Phase uncertainty

$$\pm(0.15^\circ + 0.25^\circ / \text{kHz})$$

This uncertainties are valid if the amplitude of the harmonics are higher than 0.1% of the full scale peak value.

13.9 Processing signal interface (option L45-O3)

The processing signal interface can have one or two boards, each with the same inputs and outputs. The following functional groups are isolated against each other (for details please refer 14.6, 'Functional block diagram processing signal interface'). The allowed working voltage is 25V between the groups. The testing voltage is 500V.

The analogue inputs and outputs have nominal $\pm 10\text{V}$ signal range, but in fact they are able to handle 11V resp. 12V.

The processing signal interface can consist of one or two modules, each having following inputs and outputs:

- Four analogue outputs with $\pm 10V$. The outputs are updated with each measuring cycle for normal values. The four analogue outputs have one common ground (AOut_GND) which is isolated from all other grounds.
- Four analogue inputs with $\pm 10V$. This values are displayed after each measuring cycle. The four analogue inputs have one common ground (AIn_GND) which is isolated from all other grounds.
- Four digital outputs (open collector outputs). They are updated with each measuring cycle. The four digital outputs have one common ground (DOut_GND) which is isolated from all other grounds.
- Four digital inputs. The four digital inputs have one common ground (DIn_GND) which is isolated from all other grounds.
- Two frequency inputs. They can measure frequency and direction of a rotation speed converter. The two frequency inputs have one common ground which is isolated from all other grounds but common to the ground of the auxiliary supply (Aux_F_GND). F_In1 is used to measure the frequency, F_In2 to detect the direction.
- Auxiliary supply. Here you can get an auxiliary voltage of $\pm 5V$. The ground is common with the ground of the frequency inputs (Aux_F_GND).

The connector has the following pinout:

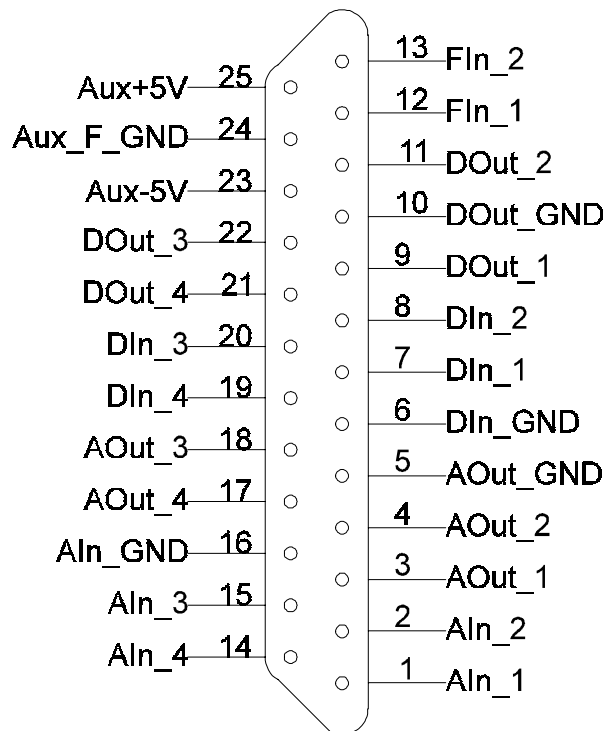

Figure 43: Processing Signal Interface Connector

For information how to setup this values see 4.4.2.2, 'Processing signal interface'.

13.9.1 Analogue inputs

Resolution: 16Bit

Uncertainty: $\pm(0.05\%$ of measuring value + 0.05% of full scale)

Input signal: $\pm 12\text{V}$

Overload capability: $-25\dots+25\text{V}$

Input resistance: $100\text{k}\Omega$

13.9.2 Analogue outputs

Update rate: once per measuring cycle

Resolution: 16Bit

Uncertainty: $\pm(0.05\%$ of output value + 0.05% of full scale value)

Output signal: $\pm 11\text{V}$

Output load: load resistance $> 2\text{k}\Omega$

13.9.3 Digital inputs

Input signal: $U_{\text{lowmax}}=1\text{V}$, $U_{\text{highmin}}=4\text{V}@2\text{mA}$, $U_{\text{highmax}}=60\text{V}@3\text{mA}$

13.9.4 Frequency inputs

Input signal: $U_{\text{lowmax}}=1\text{V}$, $U_{\text{highmin}}=4\text{V}$, $U_{\text{highmax}}=10\text{V}$

Input resistance: $100\text{k}\Omega$

Maximum frequency: 5MHz

Uncertainty: $\pm 100\text{ppm}$ of measuring value

13.9.5 Digital outputs

Open collector outputs. See 14.6, 'Functional block diagram processing signal interface'

Output high impedance: $\text{max } 30\text{V}@100\mu\text{A}$

Output low impedance: max. 1.5V@100mA

13.9.6 Auxiliary supply

Output voltage: $\pm 5V$, 10% @ 50mA

13.9.7 Frequency/direction input

Incremental sensors without direction information

Connect them to FIn_1 only. Let FIn_2 open!

Incremental sensors with direction information

Connect the frequency track (usually track A) to FIn_1.

Connect the direction track (usually track B) to FIn_2.

A positive frequency is displayed, if the direction signal is high at the rising edge of the frequency signal.

A negative frequency is displayed, if the direction signal is low at the rising edge of the frequency signal.

If this is opposite to what you want, change the tracks or use a negative frequency scaling.

13.10 Timebase

The timebase which controls the energy measuring and the internal clock has an uncertainty of $\pm 100\text{ppm}$.

13.11 Frequency measuring

0.05Hz...20kHz, $\pm 100\text{ppm}$ of measuring value

13.12 Scope memory

Size: 65536 words: 1/3 of this for each power channel. This 1/3 is for u, i and p of each power channel together

With option L45-O5 or L45-O7 :

4194304 words: 1/3 of this for each power channel. This 1/3 is for u, i and p of each power channel together

14 System design

14.1 Further connectors

14.1.1 External Synchronisation (Sync.)

14.1.1.1 Sync. connector

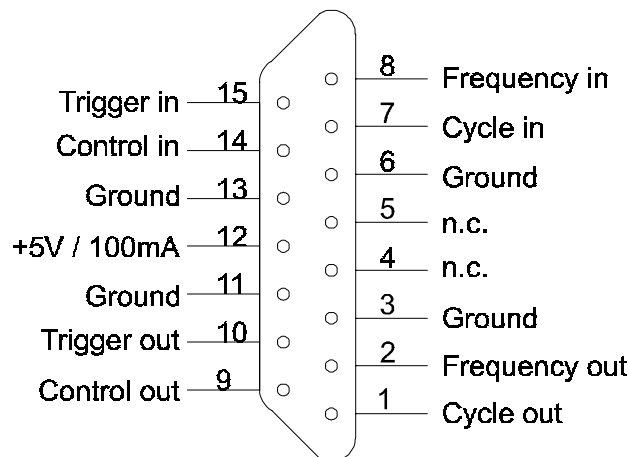

Figure 44: Sync. connector

14.1.1.2 Pin configuration of the „Sync. connector“

For the connection a 15 pole D-Sub plug with the following pin configuration is necessary:

Pin	Meaning	Pin	Meaning
1	Cycle out	9	Control out
2	Frequency out	10	Trigger out
3	Ground	11	Ground
4	Do not connect!	12	+5V / 100mA
5	Do not connect!	13	Ground
6	Ground	14	Control in
7	Cycle in	15	Trigger in
8	Frequency in		

14.1.1.3 Signal Level

All in- and outputs have CMOS - Drivers with 5V level. The supply of external sensors / drivers is provided at pin 12 with 5V and an I_{max} of 100mA. All in - and outputs are low active (0V), what means the idle level is high (+5V).

14.1.1.4 Function of the signals

Frequency in

Maximum 500kHz frequency synchronous to the frequency of the measured signal. If the LMG is set to Ext. Sync. this frequency is used for synchronisation. The rising edge of this signal replaces the positive zero crossing of the usual sync detector.

Frequency out

Measured frequency of group A, depending on the synchronisation source of the group.

Control in

Control of the energy measurement. With the next high low transition the integration is reset (if summing mode is inactive) and started. The integration stops only at transitions from low to high. The functionality of the transitions:

high → low start key
low → high stop key

Control out

Status of the energy measurement high level if the integration is stopped, low level if the integration is running.

Cycle in

Control of the measurement cycle. The period must be longer than 50ms and shorter than 60 seconds and longer than the period of the measured signal. The pulse duty factor can be 50%. Example: To measure a 5Hz signal the measurement cycle must be bigger than 200ms. Attention: Use only with valid control periods otherwise there can be a system fault of the meters. This input is normally not used.

The rising edge of this signal finishes one cycle and starts a new one.

Cycle out

Pulse for about 10µs per measurement cycle.

Trigger in/out

not used.

14.1.1.5 Synchronised measurements of two LMG450

14.1.1.5.1 General

Two LMG450 may measure synchronous if they are connected with the option L45-Z13 „Master-Slave cable“. Because of this the measurement of even 8 phases in four groups is possible. In the following documentation the groups are named: group A1 and B1 are the groups of the first LMG450. Group A2 and B2 are the groups of the second meter.

14.1.1.5.2 Connection of the meters

The Master-Slave cable must be fitted to the „Sync“-sockets of both meters. The cable is symmetric, so there is no wiring direction.

14.1.1.5.3 Pin configuration of the Master-Slave cable L45-Z13:

Plug 1	Plug 2	Signal	ST1	ST2
1	7	Cycle	Out	In
2	8	Frequency	Out	In
9	14	Control	Out	In
10	15	Trigger	Out	In
7	1	Cycle	In	Out
8	2	Frequency	In	Out
14	9	Control	In	Out
15	10	Trigger	In	Out

Ground and Screen are connected to pin 3 of both plugs.

Synchronisation stages, Set-up of the Meters

The synchronisation of the measurement can be done in different stages. Each stage is independent to all others.

A) Synchronisation of the measurement signal

This stage has no master-slave functionality. The inputs „Frequency in“ are connected with the synchronisation frequency of group A of the other power meter. The adjustments of this parameter can be set separately for each group in every meter in the *Measure* menu with *Sync*. Because of this all groups can synchronise the measuring of one common signal.

Example for the settings:

Group A1 of the first meter is set to U1.

Group A2 of the second meter is set to Ext., by this the synchronisation is set to U1 of the first meter.

Group B1 is set to Ext., by this it gets the synchronisation frequency via A2 what means U1.
Group B2 is set to Ext., by this it gets the synchronisation frequency of A1 what means U1.

If the groups A of both meters are set to Ext. there is no common synchronisation frequency and the measuring is asynchronous.

B) Synchronisation of the measuring cycle

This stage has a master-slave functionality!

For a simultaneous generation of the measuring values of two LMG the measuring cycle of the meters has to be exactly the same. Therefore the cycle time of the slave meter can be set to 0ms in the *Measure* (refer 5.1.1 Globals tab) menu.

In the status bar „0 Ext“ is shown and the green bar flashes every second.

The measuring values of both meters are now generated at exactly the same moment and a comparison of the values is possible.

Because of the master-slave meaning this adjustment can only be set in one meter. If both meters are set to 0ms the measurement stops!

C) Synchronisation of the energy measurement

This stage has no master-slave functionality but a control of a master LMG is recommended (if existing from the last top).

The energy measurement of both meters has to be set to the same mode and should be reset (refer 5.4.5.1 Integration menu).

The measurement can be started and stopped mutual with the keys „Start“ and „Stop“. A remote controlled measurement is also possible (see the following section)

D) External synchronisation signal

If the measurement should be synchronised to an additional external signal, this signal has to be connected to the pins of the D-Sub plug. The plug fitted to the meter which should be synchronised external has to be opened and the „Freq“ and „Control“ inputs must be disconnected. After this the external signal can be connected to this inputs.

If the signals are connected to the master LMG also the slave LMG can use them, because the master outputs are still connected to slave inputs:

Pin 8 Input for the external synchronisation frequency

Pin 7 Input for the cycle

Pin 14 Input for the control signal for energy metering

The connections at this pins of the master plug can be unsoldered and own signals can be connected.

Ground should be connected to Pin 6, 11 or 13.

14.1.2 External Current Sensor

You can connect your own current sensor to the external current sensor connector:

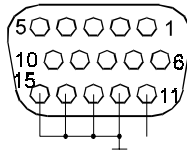

Figure 45: External current sensor connector

Connector pin assignment:

Pin No.	Comment
6	-12V / max. 100mA
7	+12V / max. 100mA
8	For ZES sensors, only!
9	For ZES sensors, only!
10	For ZES sensors, only!
11	sensor signal
12	ground
13	ground
14	ground
15	ground

Please make sure, that all 4 ground pins are connected. All other pins should be left open.

All ZES sensors have an EEPROM implemented in which we have stored the name, scaling, ranges, adjustment and delay time of the sensor. The LMG450 recognises automatically, which ZES sensor is connected and sets up the range menu. Further on we correct some of the errors the sensor produces (transfer error, delay time, ...). So you get the best measuring results with each sensor.

14.1.2.1 Several external sensors in a test bench

A common situation in test benches is, that different sensors have to be connected, controlled by a program. In this case the relevant signals have to be redirected, e.g. by a relais. Relevant are **all** 10 signals of the pins 6 to 15!

Important!

First you have to disconnect an existing sensor.

Secondly you have to wait for at least 3s.

Now you can connect the new sensor.

14.2 Functional block diagram LMG450

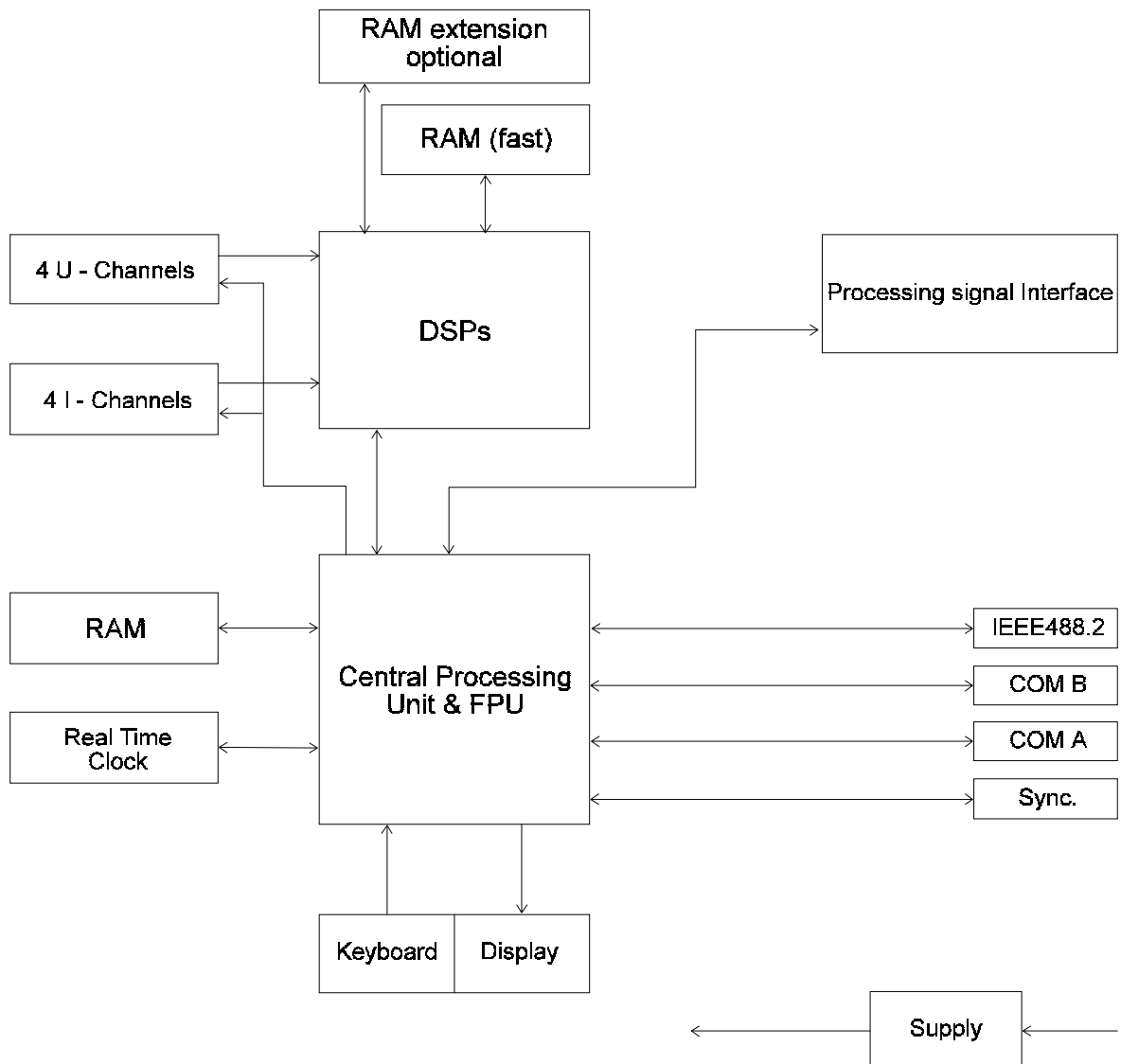

Figure 46: Functional block diagram LMG450

14.3 Functional block diagram voltage channels

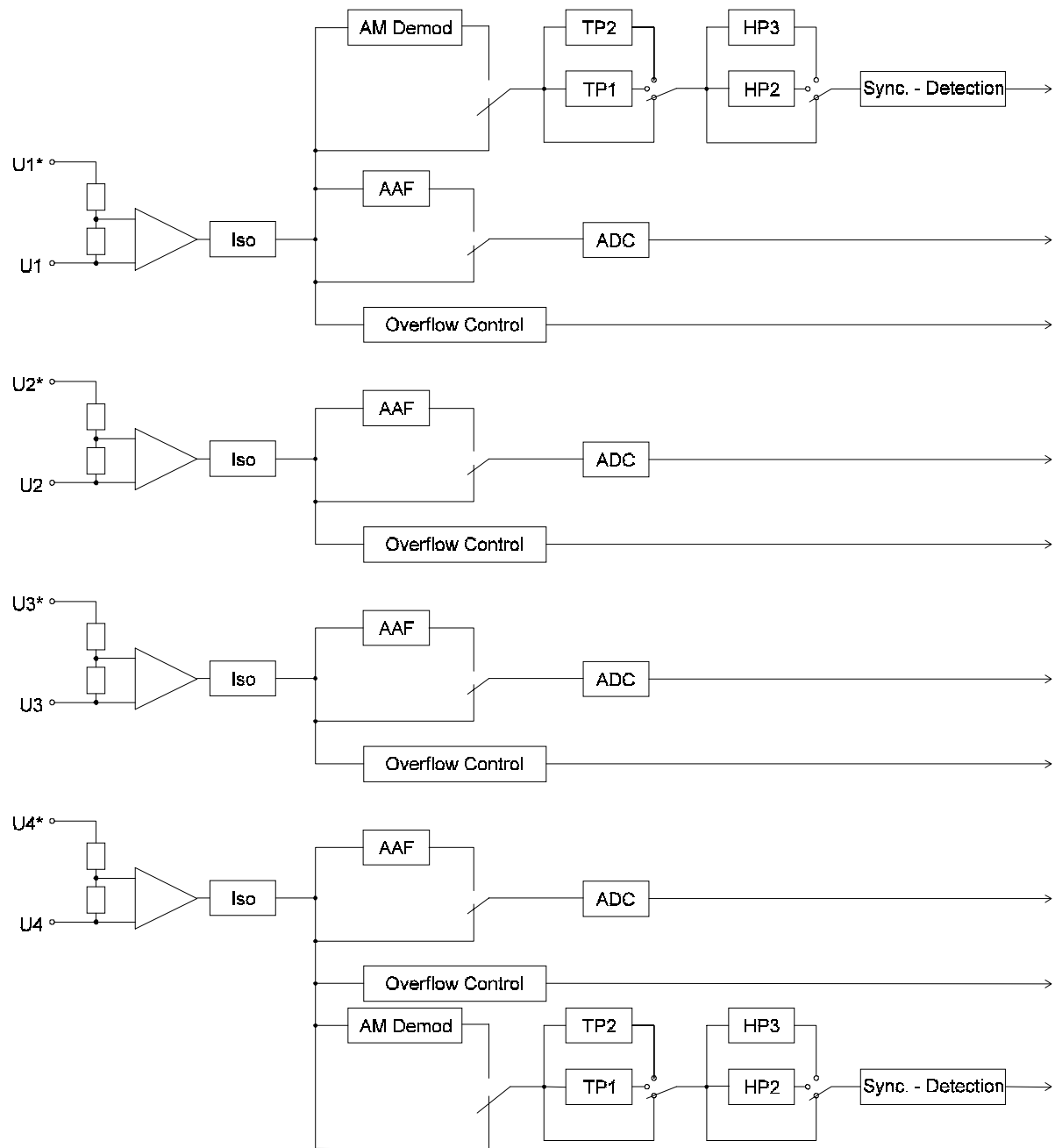

Figure 47: Functional block diagram voltage channels

14.4 Functional block diagram current channels

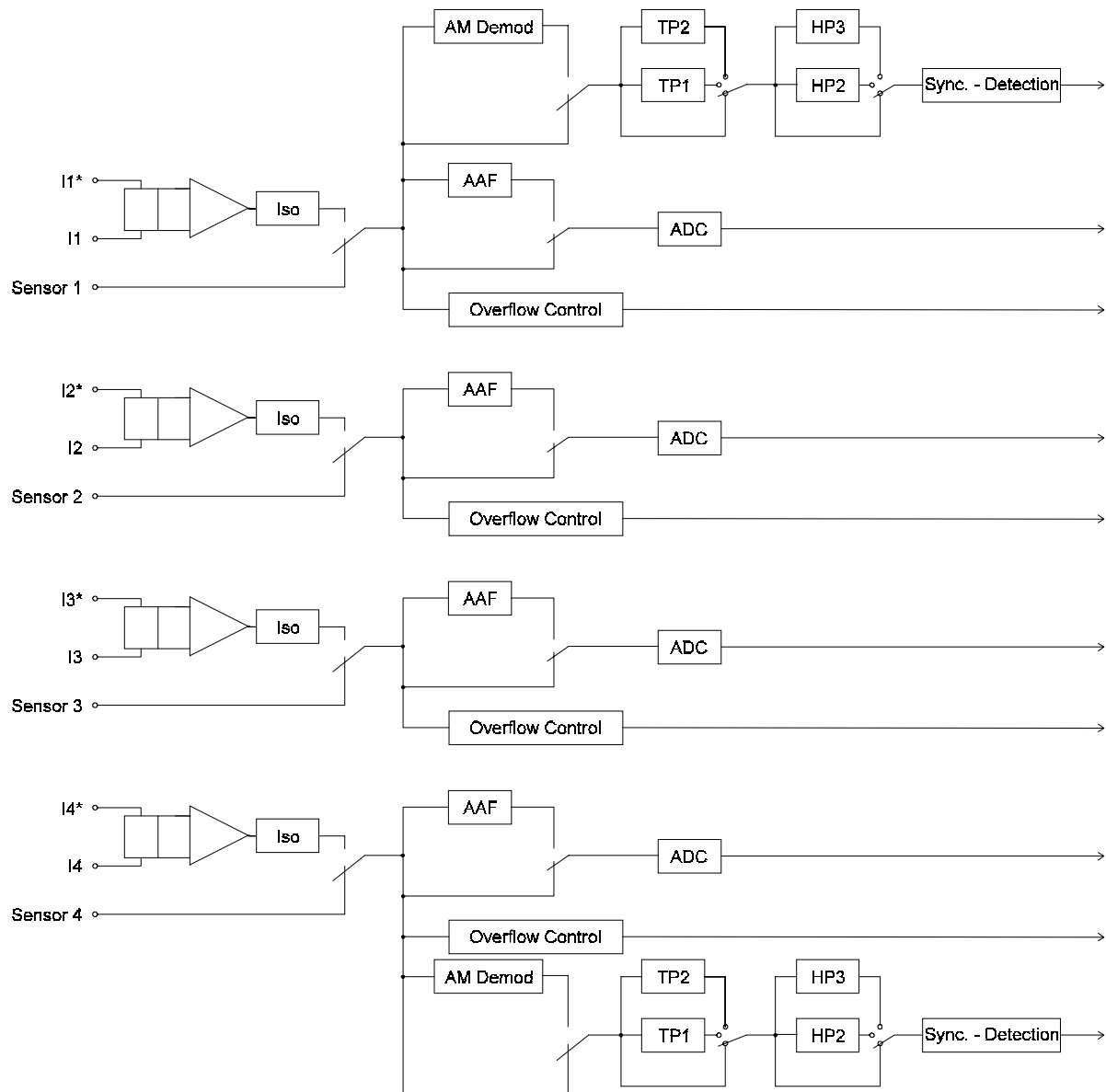

Figure 48: Functional block diagram current channels

14.5 Functional block diagram computing unit

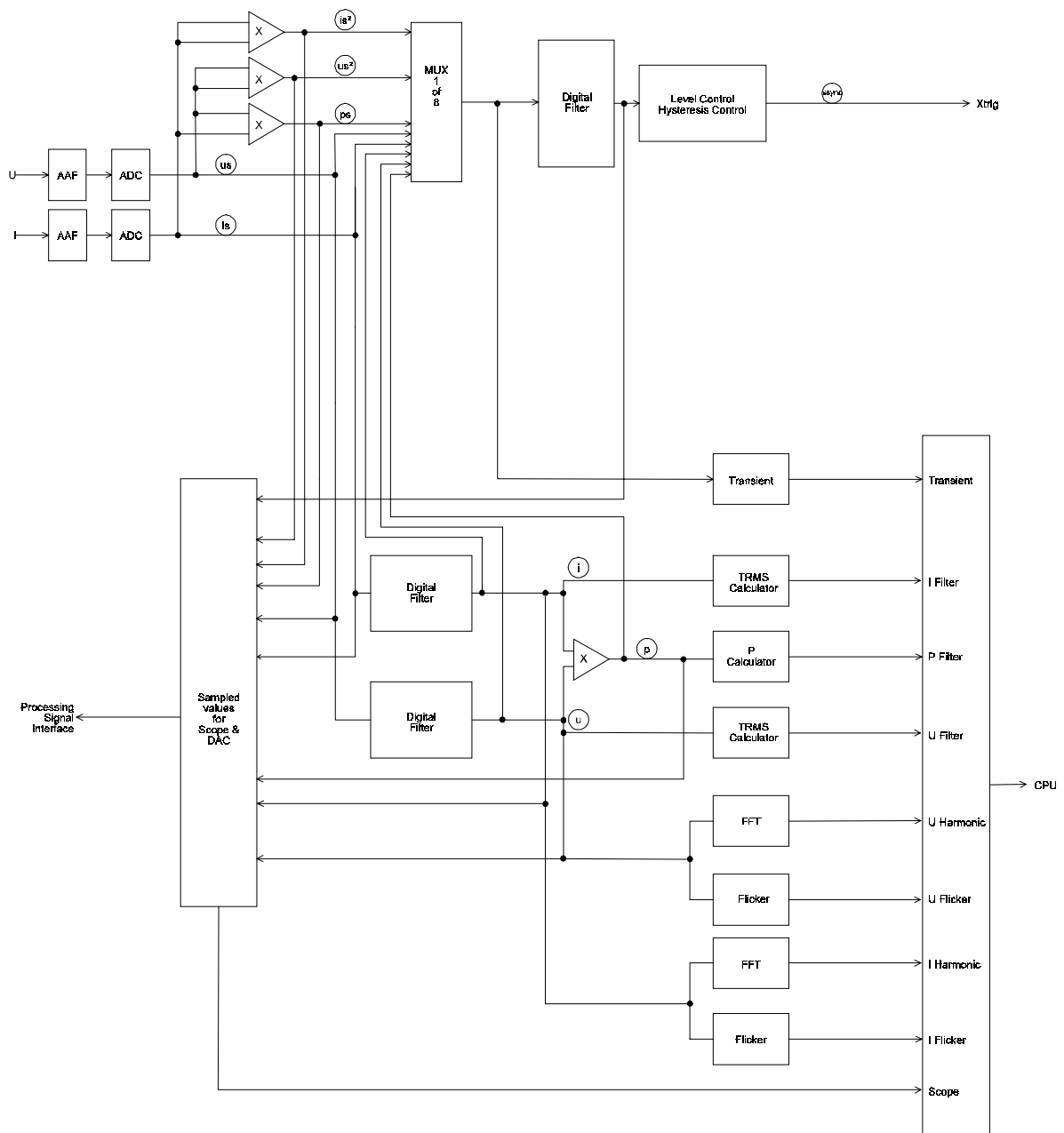

Figure 49: Functional block diagram computing unit

The labels in the circles define the signals you can select in different menus, for example extended trigger, scope, ...

14.6 Functional block diagram processing signal interface

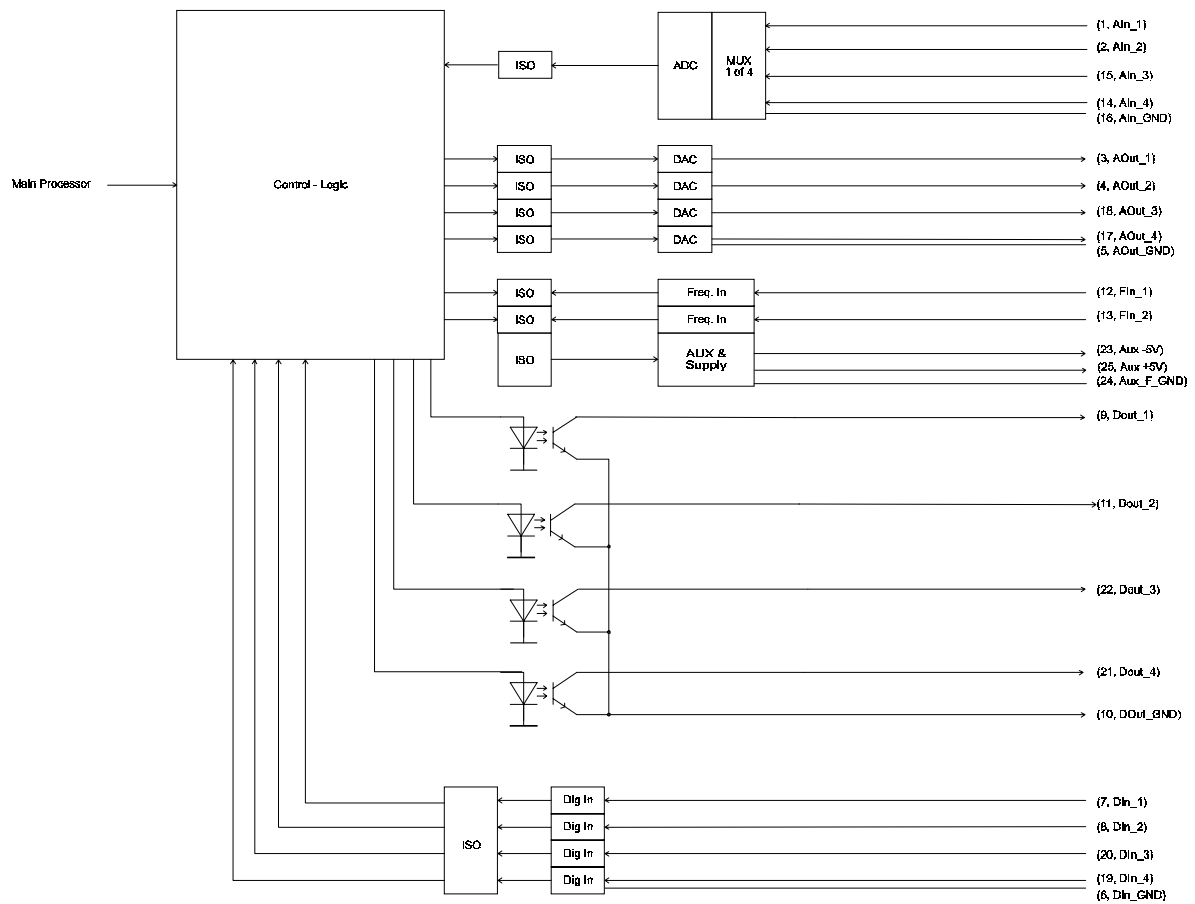

Figure 50: Functional block diagram processing signal interface

15 Glossary

Catchword	Meaning
100 Harmonics	Mode in which 99 harmonics of U, I and P are calculated.
A	
AAF	⇒ Anti Aliasing Filter.
AC	Alternating current; instantaneous values of voltage and current are time depending signals which have positive and negative values.
AC coupling	Used to remove the DC parts of a signal by using a high pass filter.
AC+DC coupling	Couples the complete signal without rejecting any parts.
Accuracy	Declaration of the errors which will be made in measuring.
Active energy	Energy which is consumed by the (usually ohmic) load.
Active power	Power which is consumed in the (usually ohmic) load.
Actual flicker level P _{mom}	⇒ Instantaneous flicker level.
Aliasing	Distortion caused by signal parts, which are created through the violation of the sampling (Nyquist, Shannon) theorem (bandwidth $\geq \frac{1}{2}$ sampling frequency). This can be prevented by using ⇒ Anti Aliasing Filter.
Allowed limits	Limits which are declared in standards.
AM	Amplitude modulation; one signal is multiplied with another one; A typical example is a rapid fire control, where a 50Hz sine wave is modulated with a slower rectangular signal.
Amplitude error	Error in the modulus of a measuring result.
Amplitude modulation	⇒ AM.
Analogue I/O	Analogue input and output, the LMG series supplies four separated inputs and outputs for analogue signals: 0-10V.
Analogue Input	⇒ Analogue I/O.
Analogue Output	⇒ Analogue I/O.
AND Condition Register	Register in which a flag is set, if two conditions are true.
Anti-Aliasing-Filter	Filter which cuts off signal parts which might produce aliasing.
Apparent energy	Energy which seems to be consumed by the load; ⇒ Apparent power. It is the integration of the apparent power.
Apparent power	Power which seems to be consumed; it is calculated by $U_{TRMS} * I_{TRMS}$ without taking care on the phase angle

Catchword	Meaning
	between them.
Application note	Several measuring or wiring problems are described in application notes of ZES ZIMMER; available also at the ZES homepage: www.zes.com .
Arbitrary block response data	⇒ Defined length arbitrary block response data.
ASCII format	Format which bases on the American standard code of information interchange with 128 symbols.
Autorange	Function which changes the ranges of the current and voltage inputs automatically, depending on the signal.
Auxiliary transducer supply	Some transducers need a separate supply. The LMG can provide this supply.
Averaged values	This values are averaged over a constant number of measuring cycles.
B	
Bandwidth	Frequency range from the lowest to the highest frequency, which can be measured or used.
Bargraph	Display of the values symbolised by bars; A typical bargraph is the spectrum display.
Basic wave	The signal part with the lowest frequency in the signal (except DC part).
Baud rate	Transfer speed of the bits in a serial data stream.
Binary	Numerical system based only on two values: 0 and 1, the data is represented only by these two binary values.
Bitmap	Format of drawing or photos.
Burden	Total load of a current transducer including wiring and input resistance.
C	
Calibration according to ISO9000	Testing of the meter accuracy traceable to national or international standards.
Capacitance against earth	Each channel has a capacitance against the earth ; this can cause systematically measuring errors which can be corrected.
CAT II	Overvoltage class for usage in normal building nets.
CAT III	Overvoltage class for usage at the PCC (point of common coupling)
CE harmonics	Harmonics measured according to EN61000-3-2; this test is requested for the CE sign.
CE-Flicker	Flicker measured according to EN61000-3-3; this test is

Catchword	Meaning
	requested for the CE sign.
Channel	Hardware which acts as an interface between the test circuit and the instrument, these are U, I and P channels ($P=U*I$).
Charge	The integration of the current over the time; this charge can be stored for example in an accumulator the unit is Ah.
Class A, B, C, D	Different kinds of equipment under test for EN61000-3-2 tests are assigned to this test classes.
COM interfaces	Serial Interface, mostly 9 pole SUB-D socket or 25 pole SUB-D socket.
Comma separated	Data format in which each value is separated by a ‘,’.
Command set	A couple of commands to remote control the instrument
Common mode rejection	Relation of the displayed value to a common floating signal on all inputs of a measuring channel; a high common mode rejection is necessary for high accuracy.
Condition instruction	Instruction which will only be executed if a condition has been fulfilled.
Constant	Value which will not change over time.
Continuous measuring	Measuring without any gaps.
Core parameter measuring circuit	The core parameters, like hysteresis and magnetic flux, can be determined through power measuring.
Correct current Correct voltage measuring	You can only measure one of these parameters in the correct way, because the impedance of the voltage / current channel has an influence on the measuring channel. This is a systematically measuring error, which can be corrected.
Coupling	This defines which parts of a signal are fed into the next stage. \Rightarrow AC coupling.
Crest factor	Ratio of peak value to TRMS value; very important when using analogue instruments.
Current clamp	Tool to measure currents; work like a removable transformer.
Current transducer	Similar to current clamps, but placed unremovable in the measurement circuit.
Cursor	Representation of the place on which the next text input will follow; in graphics the cursor marks a special point of the waveform.
Custom menu	Menu defined by the customer himself.
Cycle time	Time which defines a measuring cycle must be higher than the period time of the basic wave.
D	

Catchword	Meaning
D. U. T.	'Device under test': equipment which should be measured.
Data output format	Format which is used to transfer data from the meter to a PC or data logger.
DC value	'Direct current'; signal without alternating components. This signal is constant over the time.
Default parameters	Parameters defined by the manufacturer; the instrument is set to this parameters when it leaves the factory.
Defined length arbitrary block response data	Data transfer in blocks with a defined length and random contents inside the blocks; there can be for example the ⇒ EOS character which will be interpreted as data instead of EOS. The fastest way to get data.
Demodulation	Inverse function to ⇒ modulation; remove the carrier and you get the signal you want.
Desired integration time	Time in which the power is integrated, set by the user.
Device	Every meter or equipment take place in the measurement (Printer, PC ...).
Device under test	⇒ D. U. T.
DFT algorithm	Discrete Fourier transformation; operation with discrete values using the Fourier integral to get the harmonics of a signal.
Digital filter	Filter built up with digital components and software.
Digital Input	Like ⇒ Analogue inputs the LMG series provides digital inputs, to read external states.
Digital Output	Like ⇒ Analogue outputs the LMG series provides digital outputs, which can be used to signalise states (e.g. alarm outputs).
DIP switches	Small hardware switches to set up a meter parameter, like communication speed.
Direction input	Input for motor testing to measure the rotary direction of the motor.
Dot joiner	Connects the dots of the measured graph; it improves the look of a graph.
E	
E. U. T.	⇒ D. U. T.
Echo	Repetition of characters sent via the RS232 to the instrument.
Edit line	Line in which you can change a value or text.
Efficiency measurement	Efficiency is the relation between the output power and the

Catchword	Meaning
	input power of an E. U. T.
EN61000-3-2, EN61000-4-7 EN61000-3-3, EN61000-4-15	Standards which describe the harmonic measuring Standards which describe the flicker measuring.
End of string character	'<lf>', '<cr>', '<cr><lf>' are examples for EOS characters.
Energy	Integration of the power which is consumed by a consumer or a device in a defined time.
envelope	It is the curve which covers a mixed frequency signal connecting the peak values of the fast frequency; a curve defined by EN61000-3-2 to define if a device belongs to Class D or not.
EOS	⇒ End of string.
Equipment under test	⇒ D. U. T.
ESC key	Key used to cancel an entering mode and to quit an error message.
Extended Trigger	Mode in which the trigger conditions can be set up <u>very</u> differentiated to measure even modulated signal.
External current transformer	Device to transform high currents to lower ones.
External shunt	Changes currents into voltage with defined ratio.
External synchronisation jack	Input for an external synchronisation source.
F	
Falling edge	Opposite of rising edge; the logic signal turns from the high potential to the lower one.
FIFO	First in first out; method how the in- and output of memory is handled.
Filter	Device which cuts off frequencies which are not useful; e.g. high pass filter cuts off low frequencies.
Flicker meter	Device to measure flicker levels.
Fluctuating harmonics	Harmonics not constant over time.
Form factor	Ratio of TRMS value to rectified value; older meters could only measure the rectified value and multiply it with the form factor to get the TRMS value. The problem is, that the form factor depends on the wave form. So with other wave form you get an error. Modern instruments like the LMGs measure independent to the form factor, so you measure always correct.
Formula editor	Here you can set up formulas which will calculate different parameters from the measured values.
Freeze	The display values are not updated any more.

Catchword	Meaning
Frequency	Speed in which the period of an alternating signal repeats.
Frequency divider	Changes a high frequency into lower frequency by division with an <u>integer</u> number.
Frequency domain view	The signal is shown as spectrum over the frequency.
Frequency range	⇒ Bandwidth.
Full scale value	Highest measurable instantaneous value in the chosen range.
Fundamental	⇒ Basic wave.
G	
GPIB interface	General Purpose Interface Bus socket to transfer data from meter to PC and opposite.
Graphical display	Representation of the measured values via time or frequency.
H	
Half wave value	Values measured over the half time of the signals period.
Harm100	⇒ 100 Harmonics.
Harmonic analyser	Device to measure harmonics.
Harmonic order	Describes which order the harmonic has; e.g. of a 50Hz signal the order of the 100Hz harmonic is 2, its the second harmonic.
High impedance state	The digital output has a high impedance; the transistor is in blocking mode.
Hyperterminal	Software to exchange data between a PC and a device; included in Microsoft Windows.
Hysteresis	Difference between the switching level of the rising signal to the switching level of the falling signal.
I	
I/C indication	Indication if the load is inductive or capacitive.
Identifier	Text string representing a measuring value.
IEC61000-3-2, 2-3	⇒ EN61000-3-2.
IEC61000-4-7, -4-15	⇒ EN61000.
IEEE488.2 interface	⇒ GPIB interface.
IF/IO	Key for the set - up menus of interface and processing signal interface.
Inaccuracy of display	Because of the limited numbers on the display the displayed values have an error caused by the display (this is always ± 1 digit).
InCa flag	Flag which is set depending if the load is inductive or

Catchword	Meaning
	capacitive.
Input resistance Ri	Resistance of the input of the measuring channel.
Inrush current	Very high current at the start of a device or appliance; this can be 5 ... 100 times bigger than the current at normal operation.
Instantaneous flicker level	Time-dependent output signal of a flickermeter (output 5), which simulates an actual reaction of men's brain to the variations of light brightness caused by fluctuation of the supply voltage.
Instantaneous value	The value of a signal at one point of time.
Int. Time	Interval time; for example for integration.
Int. Value	Interval value; they are measured while the \Rightarrow Int. Time.
Integer number	Number without decimal position.
Integration mode	Mode in which the energy is calculated.
Interface	Adapter for the connection between two devices.
Interharmonic	Sinusoidal components with a frequency which is not an integer time of the fundamental.
Internal beeper	Like the PC speaker; to signalise errors.
Interval	Fixed time period.
ISO9000	Standard to guarantee the quality of devices or appliances.
L	
Level	Height of a value.
Logical devices	Log or remote; if log printer, RS232 or MCM is meant, is the question of the physical device.
Limit	Border of a value.
Linefeed	<lf>, hex0A, dec10; jump to the next line; historical from a typewriter, is the most common \Rightarrow EOS character.
Local	In this mode the LMG can be controlled directly by the user at its keyboard; \Rightarrow Remote control.
Logarithmic display	Display scaled with logarithmic axis.
Logging	Store data to memory, printer or any other storage device.
Long number	4 Bytes.
Long term flicker level Plt	A result of weighted averaging of short term flicker levels over a time period which typically equals to 2h.
Loop area	Inner area of a circle is a loop area.
Low-Pass Filter	Cuts off high frequencies.
M	
Mains	Line supply.

Catchword	Meaning
Mains switch	Switch to start up the instrument.
Manual range	The range settings have to be done by the user.
Measuring converter	Adapter to connect a meter to the \Rightarrow D. U. T.
Measuring cycle	Cycle set up from the user. After this time the meter calculates new values. The exact time depends on the synchronisation frequency.
Measuring settings	All parameters of the meter which influence the measurement.
Memory card	Random access memory card to store data.
Menu	The whole measurement settings are divided in menus to get a better survey.
Miscellaneous	In this menu you can set up several parameters which have no direct influence on the power measurement, like contrast time and date.
Multimeter	Meter which can measure several values like voltage, current and resistance.
N	
Nibble	Half of a byte; upper or lower 4bit.
Noise	Usually random signals with a high bandwidth which are superposed to the useful signal.
Nondecimal numeric program data	Data which can be represented as string instead of a number; e. g. 'Cont on' instead of 'Cont 1'.
Non-linear component losses	Losses caused by non linear loads like inductivities or capacitors or amplifier circuits.
Null modem	Type of serial connection between a PC and another device; the connection cable has two crossed conductor pairs.
O	
Open collector outputs	Passive outputs where the user has access to the collector of the output transistor. You have to connect an external voltage supply to this collector to use the output.
Operator	Instruction which is taken into the calculation: +, -, *, /.
Option Key	A string which can be used to implement software options when the LMG is at the customer.
OR Condition Register	Register which becomes true if an or condition is fulfilled.
Order	\Rightarrow Harmonic order.
Overload capability	A value how far a channel can be overloaded for a special time.
Overload condition	The instrument is in overload condition while the applied

Catchword	Meaning
	signal is too big for the selected range.
P	
Packed	Data are transferred binary instead of ASCII format
Parallel interface	⇒ Serial interface; here the data is transferred in parallel.
Parity	Even or odd number of 1's in a binary data block; The LMG works without parity.
Parsing	The LMG tries to interpret a formula or interface string and to react correctly.
Partial odd harmonic current	The harmonic content of order 21, 23 ...
PCMCIA memory cards	⇒ Memory card; PCMCIA is the old name for the PC - Card standard.
Peak current ranges	Ranges with quiet small allowed TRMS values (because of the heating up of the shunt) but very big allowed peak values; very useful to measure ⇒ Inrush currents.
Peak value	Value measured from the zero line to the highest peak of the signal.
Peak-peak value	Measured from the lowest to the highest peak of a signal.
Periodic integration mode	In this mode the integration interval is repeated periodically.
Phase	Conductor of the high potential; typically marked with L.
Phase angles	Usually the angle between current and voltage.
Phase error	The error in power caused by an additional phase shift in the measuring equipment, for example the additional phase shift of a current clamp.
Physical device	Hardware, device (RS232, printer, GPIB...).
Plot function	Mode in which cycle values (e.g. voltage, frequency, ...) are displayed over time.
Power	The energy of a time interval divided by the internal time (e.g. cycle time); so the power is always an averaged value!!
Power factor	Relation between active and apparent power.
Power measuring channel	⇒ Channel.
Power supply	Source which provides the necessary voltage.
Pretrigger	Time before the trigger condition, while which sample values are stored.
Printer header	Upper line of the printer like a title or headline.
Printer output	Socket to connect a printer.
Processing signal interface	Board with Analogue or Digital outputs.
Protocol	Arrangements for communication between devices.
Pulse controlled currents	A modulated current controls the device's power; like in a

Catchword	Meaning
	hot air fan the rapid fire control.
R	
RAM	Random access memory; you can read and write to this memory.
Range	The measuring range defines the biggest measurable signal. For best accuracy the range should be used for at least 66%.
Reactive energy	Energy which oscillates between source and load without being consumed.
Reactive power	Average \Rightarrow Reactive energy.
Real measuring time	Time in which the measuring is made, depends on \Rightarrow cycle time and \Rightarrow synchronisation frequency.
Record rate	Ratio in which the sampled values are stored in memory.
Rectified value	The average value of a rectified signal; measured by many analogue instruments \Rightarrow form factor.
Remote control	You can control the LMG via a connection to a PC.
Resolution	Resolution is <u>not</u> \Rightarrow Accuracy!!! In the LMG are two resolutions important: the analogue to digital converter has 16bit resolution, the display has 5 or 6 digit resolution.
Rise time	Time in which the signal rises from zero to the maximum (in practice from 10% to 90%).
Rotary knob	Knob used to set up parameters in the meter or move the \Rightarrow Cursor.
Rotation speed	Speed of the shaft of a motor; rpm.
RS232 interface	\Rightarrow Serial interface.
RTS/CTS	\Rightarrow Protocol to control the data flow of a \Rightarrow Serial interface.
S	
Safety socket	Connection with high safety against electric shock.
Sample memory	Memory to store the sampled measurement values.
Sample value	Value of a signal measured at a defined time \Rightarrow Instantaneous Value.
Sampling frequency	Frequency with which the samples of a signal are taken.
Scaling	Resolution of an axis or factor which has an influence on the measured value.
Scope function	In this mode the LMG works like an oscilloscope and displays \Rightarrow Sample values.
SCPI commands	A standardised set of commands to remote control the LMG.

Catchword	Meaning
Sensors	A small external device which converts a current or voltage to a signal the LMG can measure.
Serial poll	A PC program can ask every connected instrument in series if it has data to send. Used by \Rightarrow GPIB.
SHORT headers	Shorter set of commands, equivalent to \Rightarrow SCPI.
Short term flicker level	A result of statistical processing of instantaneous flicker level quantities over a time period, which typically equals to 10 min.
Shunt input	Special socket to connect the small voltages of an external shunt to the correct channel.
Shuttle knob	\Rightarrow Rotary knob.
Signal coupling	\Rightarrow AC coupling; This coupling affects the measured values.
Signal source	Where you get a signal from; e.g. frequency generator.
Slewrate	Relation between the voltage rise and the used time.
Softkey	This keys change the meaning depending on the menu.
Software options	Options which can be installed with software.
Software update	Updates your software of the LMG. Available on the homepage: www.zes.com .
Status byte register	Register in which several flags are set according to the status of the LMG.
String	Characters lined up in a row.
Sub menu	A subdivision of a menu.
Synchronisation	Periodic signals have to be measured for an integer number of periods. So the LMG must synchronise it's measuring to the signal to get stable values.
System time	Main time of the meter.
T	
Table	Special format for output of measuring values in a table.
Terminal	Each device which takes an account on a data transfer.
Terminal program	\Rightarrow Hyperterminal.
THD values	Total harmonic distortion, relation of the harmonics of a signal to the fundamental.
Time depended signals	Signal of which the values change depending on the time.
Time domain views	Values are displayed over time.
Total Harmonic Current	Sum of all harmonics starting with 2 nd order.
Total harmonic distortion	\Rightarrow THD.
Total harmonic distortion factor including noise (THD+N)	\Rightarrow THD with included noise.

Catchword	Meaning
Transient	A short, unusual event on a signal.
Transient mode	Mode in which events can be recorded.
Trigger condition	The trigger starts depending on this condition.
Trigger level	Level on which the trigger starts.
Trigger signal	Signal which gives the trigger event.
TRMS	⇒ True root mean square.
True root mean square	The average of a squared signal.
V	
Variables	Values calculated by ⇒ Formula Editor.
Visual display	Display what you can see in the moment.
Voltage transformers	Changes voltage levels.
Z	
Zero crossing	When the signal passes the zero axis. The positive zero crossing is usually used for ⇒ Synchronisation.
Zoom	Zoom in: enlarge the display Zoom out: reduce the visual display.

16 Common Index

*

*RST Default value 137

/

/nquery/ 134

/qonly/ 133

<

<list> data 134

I

100 harmonics measuring mode 123

1kV input 262

A

AC 92; 110

accuracy 245; 248; 255; 261

active energy 93; 94

active impedance 93

active power 92; 94

analogue I/O 53

analogue inputs 59; 266; 267

analogue outputs 60; 266; 267

angle 92

apparent energy 93; 94

apparent impedance 93

apparent power 92; 94

Aron 33; 34; 81

 wiring 45

auto range 86

auto zero 255

autorange 85

auxiliary supply 266; 268

average values 93

B

basic wave 124

battery 256

BMP2PC 237

C

calculating the measuring error 245

calculation of measuring values 87; 109; 118; 124

calibration 254

capacitance against earth 259

capacitance between U and I 260

CE-flicker measuring mode 117

channel separation 260

charge 93

colours 55

COM A 233

COM B 233

ComA 54

ComB 53

Commands 135

common mode error 259; 260

condition instruction 66

configuration 81; 107; 117; 123; 129

 default 74

 load 74

 save 74

configurations

 saving and restoring 74

connection of the LMG450 41

connectors 52; 232

 further 269

constants 66

contrast 55

coupling 82; 130

coupling mode 262

crest factor 92; 110

current 51; 91; 97; 109; 111; 119; 120; 124; 126

 sum 94

current ranges 259

current sensor

 external 273

current sensors 263

custom.....	52
Custom menu	63; 105; 115; 121; 127
cycle.....	81

D

D.....	125
data	
import	241
data logging.....	105; 115; 121; 127; 132; 235
date	
setup of	55
dc.....	119
DC value	91; 110
default.....	51; 96; 111; 119; 126
default settings	41
Default value	137
definition of measuring values	87; 109; 118; 124
delete	
setup	41
digital inputs	61; 266; 267
digital outputs.....	61; 266; 267
dimensions	257
display.....	54
display of values.....	95; 110; 119; 125; 132; 258
dmax	119

E

editor.....	64
efficiency.....	72
EN61000-3-2.....	115
EN61000-3-3.....	119; 121
EN61000-4-15.....	119
end of logging.....	236
energy	93; 94; 98
ENTER	52
entering identifiers and text	74
entering numerical values	79
Environment variables	67
error messages.....	243
ESC.....	52
evaluation of harmonics	107
EXCEL.....	242
expressions.....	66
ext. current input	261
extended.....	104
external current sensor.....	273
External Synchronisation (Sync.)	269

F

factory settings	41
fans	255
faq.....	245
features and application areas	27
filter	83; 108; 130; 263
hf rejection	263
flicker.....	120
flicker mode	117
floppy disk drive.....	240
floppy drive	235
fluctuating harmonics	108
form factor.....	92
format	
output.....	238
formula editor.....	64
freeze	51
frequency input.....	72
frequency inputs	266; 267
Frequency measuring.....	268
frequently asked questions.....	245
Fresnel diagramm	103
front panel	51
function fault	249
functional block diagram	
computing unit.....	277
current channels	276
LMG450.....	274
processing signal interface.....	278
voltage channels	275
functions.....	68
fundamental.....	124
further connectors	269
fuse	257

G

general	27
general handling	29
general menus.....	55
general set-up	41
globals tab	
measuring menu	81; 107; 117; 123; 129
Glossary	279
GPIB	233
grammar	65
graph.....	51; 99; 113; 121; 127
graphical display.....	99; 113; 121; 127; 132
group A/B tab	
measuring menu	82; 108; 129
range menu.....	85
group concept	31

H

handling	29
harmonic mode	123
harmonics	107
header	95
HF rejection filter	263

I

I	53
I*	53
identifiers	30; 63; 64; 74; 239
IEC 625	233
IEC61000-3-2	110
IEC61000-4-15	117
IEEE	133
IEEE488	53
IEEE488.2	233
IEEE488.2 commands	135
IF/IO	52; 57
impedance	93
import of data	241
input resistance	259
inrush current	92; 97
installation	41
instructions	65
instructions and warnings	19
instrument controls	51
int. time	52
Int. val	120
int. value	51
integrated values	93
integration	98; 272
start	99
stop	99
interface settings	57
interface testing	227
interfaces	57; 133
intervals	
output	237

K

keywords	68
----------------	----

L

L45-O1	133
L45-O12	262
L45-O15	262

L45-O3	59; 265
L45-O4	117
L45-O5	129; 268
L45-O6	35; 44
L45-O7	268
L45-O8	123
L45-Z13	271
L45-Z318	53
LAN adaptor	53
limits	111
Linked values	35; 88
list data	134
Local variables	67
logging	105; 115; 121; 127; 132; 235
logging profiles	236
long term flicker	118
long time evaluation	108; 112

M

maintenance	254
Master-Slave	271
measure	52
Measurement of high currents	47
Measurements at middle and high voltage systems	48
Measurements at middle and high voltage systems	
without N	49; 50
measuring	81; 107; 117; 123; 129
measuring channels	259
Measuring circuit (typical) for star to delta conversion	
(option L45-O6)	44
measuring circuit for measuring efficiency of 3/1 phase	
systems	43
measuring circuit for measuring efficiency of 3/3 phase	
systems	46
measuring circuit for typical line applications using the	
internal current path	42
measuring circuit using an external current sensor	46
measuring configuration	81; 107; 117; 129
measuring menu	
globals tab	81; 107; 117; 123; 129
group A/B tab	82; 108; 129
measuring mode	
100 harmonics	123
CE flicker	117
normal	81
prCE harmonics	107
transient	129
measuring ranges	85; 109; 118; 124; 132
measuring uncertainty	261
measuring values	
calculation	87; 109; 118; 124
memory card drive	240
memory drive	235

menu	
custom.....	63
user defined.....	63
messages	
error.....	243
misc.....	52; 55; 255; 258
miscellaneous.....	245
MotorTorque-SOFT option.....	72

N

New menu tab.....	63
normal measuring mode.....	81
nquery.....	134
null modem.....	233
numerical values.....	79

O

operators.....	69
option	
L45-O1.....	133
L45-O12.....	262
L45-O15.....	262
L45-O3.....	59; 265
L45-O4.....	117
L45-O5.....	129; 268
L45-O6.....	35; 44
L45-O7.....	268
L45-O8.....	123
MotorTorque-SOFT.....	72
options.....	72; 268
options key.....	62
output devices.....	236
output formats.....	238
output intervals.....	237
overload capability.....	259

P

parallel Port.....	234
PE.....	53
peak-peak value.....	92
phase error.....	262
physical devices.....	232
plot function.....	101; 127
Plt.....	119
Pmom.....	119
power.....	51; 92; 94; 97; 110; 112; 120; 126
power factor.....	92; 94
prCE-harmonic measuring mode.....	107
print/log.....	51

printer.....	54; 234; 235; 237
printing scripts.....	72
processing signal interface.....	59; 265
Pst.....	119

Q

qonly.....	133
------------	-----

R

range.....	85; 109; 118; 124; 132
auto.....	85
range menu	
group A/B tab.....	85
sense/more tab.....	86
ranges.....	52; 259
reactive energy.....	93; 94
reactive impedance.....	93
reactive power.....	92; 94
reading memory cards with a laptop.....	240
rear panel.....	52
rectified value.....	92
remarks.....	70
remote control.....	133
reset.....	41; 74
R _{sce}	109
RST Default value.....	137

S

safety instructions.....	19; 20
sampling.....	259
save/recall.....	51
saving and restoring configurations.....	74
scope function.....	99
SCPI.....	133
script editor.....	64
condition instruction.....	66
constants.....	66
examples.....	70
expressions.....	66
functions.....	68
general.....	65
grammar.....	65
instructions.....	65
keywords.....	68
operators.....	69
remarks.....	70
variables.....	67
sense/more tab	
range menu.....	86

sensor.....	46
sensor input.....	53
short term flicker.....	117
software update.....	256
spectrum.....	113
speed and torque calculation.....	72
star to delta conversion.....	32; 35; 88
start.....	51
start of logging.....	235
status.....	51
status line.....	54
stop.....	51
storage media.....	240
storage of values.....	235
memory card and printer.....	105; 115; 121; 127; 132
suffix.....	133
sum	
current.....	94
voltage.....	94
sync.....	53; 81; 269
connector.....	269
pin configuration.....	269
signal level.....	269
signals.....	270
Synchronisation	
external.....	81; 269
synchronised measurements.....	271
syntax.....	133
system design.....	269

T

technical data.....	257
testing the interface.....	227
tests according EN61000-3-2.....	115
tests according EN61000-3-3.....	121
text.....	74
time	
setup of.....	55
Timebase.....	268
torque calculation.....	72
total harmonic distortion.....	110
total values.....	94
transformer adjustment.....	262
Transient mode.....	129

trms.....	91
true root mean square.....	91

U

U.....	53
U*.....	53
uncertainty.....	245; 248; 255; 261
unpacking and putting into operation.....	41
update.....	256
usage of the manual.....	28
user defined menu.....	63
User defined tab.....	63

V

Values from single measuring.....	91
variables.....	67
Vars tab.....	63
vector function.....	103
voltage.....	51; 91; 97; 109; 111; 119; 120; 124; 126
sum.....	94
voltage ranges.....	259

W

weight.....	257
Wiring	
'2+2 Channels'.....	33; 34; 87
'2+2, UΔI*->UΔIΔ'.....	37; 90
'2+2, UΔI*->U*I*'.....	38; 91
'3+1 Channels'.....	33; 87
'3+1, UΔI*->UΔIΔ'.....	36; 89
'3+1, UΔI*->U*I*'.....	37; 89
'3+1, U*I*->UΔIΔ'.....	36; 89
'4+0 Channels'.....	33; 87

Z

zero adjustment.....	255
----------------------	-----

17 Interface command index

*	
*CLS.....	135
*ESE.....	135
*ESR?.....	136
*IDN?.....	136
*OPC.....	136
*OPC?.....	137
*PRE.....	137
*RST.....	137
*SRE.....	138
*STB?.....	138
*TRG.....	138
*TST?.....	138
*WAI.....	139

/	
/nquery/.....	134
/qonly/.....	133

:	
:CALCulate	
:ENVironment.....	139
:FORMula	
[:DEFine].....	140
:LIMit	
:CLASs.....	140
:DMAX.....	141
:FCURrent.....	141
:FVERsion.....	141
:PFACtor.....	142
:POWer.....	142
:RSCE.....	142
:SYSTem.....	142
:VERsion.....	143
:ZREF.....	143
:ZTEST.....	143
:DISPlay	
:CONTRast.....	144
:RESet.....	144
:FETCh	
[:SCALar]	

:CURRent	
:AC?.....	145
:CFACTor?.....	145
:DC?.....	146
:FFACTor?.....	146
:FSCale?.....	146
:INRush?.....	146
:MAXPk?.....	147
:MINPk?.....	147
:PHASe?.....	147
:PPEak?.....	147
:RECTify?.....	147
:RUSed?.....	148
[:TRMS]?.....	148
:CYCLe	
:COUNt?.....	148
:SNUMber?.....	149
:TIME?.....	149
:DINPut?.....	149
:ENERgy	
:APPArent?.....	150
:CHARge?.....	150
:REACTive?.....	151
:TIME?.....	151
[:ACTive]?.....	150
:FLICKer	
:LTRemain?.....	154
:PHWave?.....	155
:SOURce	
:APMoment?.....	155
:DC?.....	156
:DELTat?.....	156
:DMAX?.....	156
:DTMViolation?.....	156
:HWTRms?.....	157
:PLT?.....	157
:PMOMentary?.....	157
:PST?.....	157
:RESult?.....	158
:STATe?.....	158
:STRemain?.....	158
[:EUTest]	
:APMoment?.....	152
:DC?.....	152
:DELTat?.....	152
:DMAX?.....	152
:DTMViolation?.....	153

:HWTRms?.....	153	:PHASe?.....	173
:PLT?.....	153	:PPHase?.....	173
:PMOMentary?.....	153	:STATe?.....	173
:PST?.....	154	:THDistort?.....	174
:RESult?.....	154		
:FREQuency		:POWer	
:FINPut?.....	159	:AACTive?.....	174
:SAMPle?.....	159	:AAPParent?.....	174
[:SSource]?.....	159	:APParent?.....	175
:HARMonics		:AREactive?.....	175
:AMPFactor?.....	160	:FSCale?.....	175
:AMPower?.....	160	:ICAPacity?.....	176
:APFactor?.....	160	:PFACTOR?.....	176
:APOWer?.....	161	:PHASe?.....	176
:CDResult?.....	161	:REACTive?.....	176
:CURRent		[:ACTive]?.....	175
:AAMPLitude?.....	162	:RESistance	
:AFUNDamental?.....	162	:ASResist?.....	177
:AMPLitude?.....	162	:IMPedance?.....	177
:FProtz?.....	163	:RSIMpedance?.....	177
:FRESult?.....	163	:SSYStem?.....	178
:GFResult?.....	163	:TRANsient	
:IAMPLitude?.....	164	:STATe?.....	178
:LIMit?.....	164	:VARIABLE?.....	178
:LTResult?.....	165	:VNAME?.....	179
:OLIMit?.....	165	[:VOLTage]	
:PHASe?.....	165	:AC?.....	179
:POHarmonic?.....	165	:AINPut?.....	179
:POLimit?.....	166	:CFACtor?.....	180
:SAverage?.....	166	:DC?.....	180
:SMOothed?.....	166	:FFACtor?.....	180
:STATe?.....	166	:FSCale?.....	180
:THARmonic?.....	167	:MAXPk?.....	181
:THDistort?.....	167	:MINPk?.....	181
:LTRemain?.....	167	:PHASe?.....	181
:POWer		:PPEak?.....	181
:ACTive.....	168	:RECTify?.....	182
:APParent.....	168	:RUSed?.....	182
:DISTortion.....	168	[:TRMS]?.....	182
:REACTive.....	169	:FORMat	
:VOLTage		:DATA.....	183
:IAMPLitude?.....	170	:GTL.....	225
[:VOLTage]		:INITiate	
:AMPLitude?.....	169	:CONTInuous.....	183
:GFResult?.....	170	:COPY.....	184
:HWCFactor?.....	170	:IMMEDIATE.....	184
:LIMit?.....	171	:INPut	
:LTResult?.....	171	:COUPLing.....	185
:MAMPLitude?.....	171	:INSTrument	
:MAXCfactor?.....	171	:SElect.....	186
:MAXPhi?.....	172	:MEMory	
:MINCfactor?.....	172	:FREeze.....	186
:MINPhi?.....	172	:SSIZe.....	187
:OLIMit?.....	172	:READ	
		[:SCALar]	

:CURRent	[:SSource]?	159
:CFACtor?		145
:DC?		146
:FFACtor?		146
:FSCale?		146
:INRush?		146
:MAXPk?		147
:MINPk?		147
:PHASe?		147
:PPEak?		147
:RECTify?		147
:RUSed?		148
[:TRMS]?		148
:CYCLe		
:COUNt?		148
:SNUMber?		149
:TIME?		149
:DINPut?		149
:ENERgy		
:APParent?		150
:CHARge?		150
:REACTive?		151
:TIME?		151
[:ACTive]?		150
:FLICKer		
:LTRemain?		154
:PHWave?		155
:SOURce		
:APMoment?		155
:DC?		156
:DELTat?		156
:DMAX?		156
:DTMViolation?		156
:HWTRms?		157
:PLT?		157
:PMOMentary?		157
:PST?		157
:RESult?		158
:STATe?		158
:STRemain?		158
[:EUTest]		
:APMoment?		152
:DC?		152
:DELTat?		152
:DMAX?		152
:DTMViolation?		153
:HWTRms?		153
:PLT?		153
:PMOMentary?		153
:PST?		154
:RESult?		154
:FREQuency		
:FINPut?		159
:SAMPle?		159
[:SSource]?		159
:HARMonics		
:AMPFactor?		160
:AMPower?		160
:APFactor?		160
:APOWER?		161
:CDResult?		161
:CURRent		
:AAMPLitude?		162
:AFUNdamental?		162
:AMPLitude?		162
:FPRotz?		163
:FRESult?		163
:GFResult?		163
:IAMPLitude?		164
:LIMit?		164
:LTResult?		165
:OLIMit?		165
:PHASe?		165
:POHarmonic?		165
:POLimit?		166
:SAVerage?		166
:SMOothed?		166
:STATe?		166
:THARmonic?		167
:THDistort?		167
:LTRemain?		167
:VOLTage		
:IAMPLitude?		170
[:VOLTage]		
:AMPLitude?		169
:GFResult?		170
:HWCfactor?		170
:LIMit?		171
:LTResult?		171
:MAMPLitude?		171
:MAXCfactor?		171
:MAXPhi?		172
:MINCfactor?		172
:MINPhi?		172
:OLIMit?		172
:PHASe?		173
:PPHase?		173
:STATe?		173
:THDistort?		174
POWER		
: APParent?		168
: DISTortion?		168
:ACTive?		168
:REACTive?		169
:POWER		
:AACTive?		174
:AAPParent?		174
:APParent?		175

:AREActive?.....	175	:HARMonics	
:FSCale?.....	175	:FDIV.....	195
:ICAPacity?.....	176	:IStart.....	195
:PFACtor?.....	176	:REFeRence.....	195
:PHASe?.....	176	:SMOoth.....	195
:REACtive?.....	176	:TIME.....	196
[:ACTive]?.....	175	:INTEgral	
:RESistance		:DATE.....	196
:ASResist?.....	177	:INTerval.....	197
:IMPedance?.....	177	:MODE.....	197
:RSIMPedance?.....	177	:STATe?.....	197
:SSYStem?.....	178	:TIME.....	198
:TRANsient		:RPVAlues.....	198
:STATe?.....	178	:SWEep	
:VARIable?.....	178	:TIME.....	199
:VNAME?.....	179	:TRANsient	
[:VOLTage]		:ACRegister.....	199
:AC?.....	179	:ALIMit.....	200
:AINPut?.....	179	:BLIMit.....	200
:CFACtor?.....	180	:CHANnels.....	200
:DC?.....	180	:DURation.....	200
:FFACtor?.....	180	:OCRegister.....	201
:FSCale?.....	180	:PRETrigger.....	201
:MAXPk?.....	181	:RTIME.....	201
:MINPk?.....	181	:SIGNal.....	202
:PHASe?.....	181	:SRDT.....	202
:PPEak?.....	181	:SRDY.....	202
:RECTify?.....	182	:SROVer.....	202
:RUSed?.....	182	:VOLTagE	
[:TRMS]?.....	182	:IDENtify.....	203
:SENSe		:RANGe	
:AINPut		:AUTO.....	203
:FSCale.....	187	:LINTern?.....	204
:ZERO.....	188	[:UPPer].....	204
:ARON.....	188	:SCALE.....	204
:AVERage		:WAVEform	
:COUNT.....	189	:CYCLes.....	205
:CURRent		:IUPDate.....	205
:DETEctor.....	189	:SATRigger?.....	205
:IDENtify?.....	190	:SBTRigger?.....	206
:RANGe		:SCTRigger?.....	206
:AUTO.....	190	:SRATE?.....	206
:LINTern?.....	191	:SSAMples.....	206
[:UPPer].....	191	:WAVE?.....	207
:SCALE.....	191	:WIRing.....	207
:FILTer		:ZPReject.....	208
:AFILter.....	191	:SOURce	
[:LPASS]		:DIGital	
[:STATe].....	192	:CONDition.....	208
:FINPut		:LIMit.....	209
:SCALE.....	193	:VALue.....	209
:FLICKer		:VOLTagE	
:PERiods.....	194	:SCALE	
:STIME.....	194	:FSCale.....	210

:ZERO.....	210
:VALue.....	210
:STATus	
:OPERation	
:CONDition?	211
:ENABle.....	211
:NTRansition	211
:PTRansition.....	212
[:EVENT]?.....	211
:PRESet.....	212
:QUEStionable	
:CONDition?	212
:ENABle.....	213
:NTRansition	213
:PTRansition.....	213
[:EVENT]?.....	213
:SYSTem	
:BEEPer	
:IMMediate.....	214
:DATE.....	214
:ERRor	
:ALL?	216
:COUNt?	216
[:NEXT]?.....	216
:HELP	
:HEADers?	217
:SHEDers?.....	217
:KEY	218
:LANGuage	218
:OPTions?.....	219
:PHEDer	219
:TIME.....	220
:VERSion?.....	220
:TRIGger	
:ACTion	220
:ICURrent.....	221
:INTerval	
:RESet	221
:STARt	222
:STOP	222
[:SEQuence]	
:COUPle.....	223
:EXTend	
FILTer.....	223
HYSTEResis.....	224
LEVel.....	224
SOURce	224
:SOURce	225

<

<list> data	134
-------------------	-----

A

AC	
current.....	145
voltage.....	179
action	220
active	
energy	150
power	175
active power	
harmonics.....	168
active serial resistance	177
actualisation	
measuring values	184
AIHI.....	187
AILO.....	188
Ain.....	179
AIVA?.....	179
amplitude	
current harmonics	162
voltage harmonics.....	169
analogue input	
full scale.....	187
voltage.....	179
zero position.....	188
analogue output	
full scale.....	210
zero position.....	210
analogue outputs	
value	210
AND condition register	
transients.....	199
anti-aliasing.....	191
AOHI	210
AOIX	210
AOLO	210
apparent	
energy	150
power	175
apparent power	
harmonics.....	168
ARON	188
AVER	189
average.....	189
average active power	174
average amplitude	
current harmonics	162
average apparent power	174
average reactive power	175
averaged momentary flicker level.....	152; 155

B

BEEP	214
beeper	214

C

Calculations	
environment	139
capacitive	176
change command set	218
channels	
transients	200
charge	150
class D result	161
clear	
error/event queue	135
event registers	135
command set	
change	218
condition	
digital outputs	208
CONT	183
continuous execution	183
contrast	144
COPY	184
COUNT?	148
counter	
measuring cycle	148
COUPL	223
coupling	
signal	185
coupling mode	
trigger	223
crest factor	170
current	145
maximum	171
minimum	172
voltage	180
current	
AC	145
autorange	190
crest factor	145
DC	146
fluctuating harmonics result	163
form factor	146
full scale	146
harmonic phases	165
harmonics amplitude	162
harmonics average amplitude	162
harmonics limit	164
harmonics maximum duration	163
harmonics result	165

inrush	146
interharmonics	164
maximum	147
maximum averaged fundamental	162
minimum	147
partial odd harmonic	165
peak peak	147
phase angle	147
range	191
range usage	148
rectified	147
reset inrush	221
scaling	191
smoothed averaged harmonic	166
smoothed harmonic	166
THD	167
total harmonic	167
trigger inrush	221
TRMS	148
current sensor	
identify	190
CYCL	199
cycle	199
sample counter	149
cycle time	199
CYCR?	149

D

D	168
d(t)	152; 153; 156
D?	168
data output format	183
date	214
start energy	196
system	214
DC	152; 156
current	146
voltage	180
dcl	152
dcs	156
device	
reset	137
DIFQ?	159
DIFS	193
DigFrq	159
digital inputs	149
digital outputs	
condition	208
limits	209
value	209
display	
contrast	144

default values	144
reset	144
DISR	144
DIST?	149
distortion power	168
dmax	152; 156
dmax limit	141
dmaxl	152
dmaxs	156
DOCO	208
DOIX	209
DOLI	209
dt	
transients	202
dtl	152
dts	156
dy	
transients	202

E

EDIT	143
edition	
flicker standard	141
harmonic standard	143
EI?	150
energy	
active	150
apparent	150
reactive	151
reset	221
start	222
start date	196
start time	198
state	197
stop	222
time interval	197
ENV	139
environment	139
EP	150
EP?	150
EQ	151
EQ?	151
ERR?	216
ERRALL?	216
ERRCNT?	216
error	
oldest	216
error/event queue	
clear	135
errors	216
number of	216
ES	150
ES?	150

EVAL	140
evaluation	
harmonics	140
event duration transients	200
event registers	
clear	135
Event Status	
Enable Register	135
Register	136
example	
basic	226
SCPI	228
SHORT	230
execution	
continuous	183
extended trigger	
filter	223
hysteresis	224
level	224
source	224
external shunt input	189

F

f	159
FAAF	191
FDIV	195
FILT	192
filter	192
anti-aliasing	191
extended trigger	223
FLCF?	170
FLCN?	172
FLCX?	171
FLDC?	152
FLDL	141
FLDT?	152
FLDX?	152
flicker	
averaged momentary level	152; 155
d(t)	152; 153; 156
dc	152; 156
dmax	152; 156
half wave TRMS	153; 157
momentary level	153; 157
periods	194
Plt	153; 157
Pst	154; 157
remaining long time	154
remaining short time	158
result	154; 158
short term measuring time	194
start	222
state	158

stop	222
Zref	143
Ztest	143
flicker standard	
version, edition	141
FlkPer	194
FLLT?	153
FLMO?	152
FLMS?	153
FLMV?	153
FLPH?	155
FLPN?	172
FLPS	194
FLPX?	172
FLRE?	154
FLRM?	153
FLST?	154
FLTR?	154
FLUP?	173
FNRM	141
FORM	140
form factor	
current	146
voltage	180
format	
data output	183
Formula Editor	140
environment	139
freezes	
scope	186
FREQ?	159
frequency	
processing signal interface	159
sample	159
synchronisation source	159
frequency divider ratio	195
frequency input	
scaling	193
FRMT	183
FRZ	186
FSDC?	156
FSDT?	156
FSDX?	156
FSI?	146
FSLT?	157
FSMO?	155
FSMS?	157
FSMV?	156
FSP?	175
FSRE?	158
FSRM?	157
FSST?	157
FSTA?	158
FSTR?	158

FSU?	180
FTIM	194
full scale	
analogue input	187
analogue output	210
current	146
power	175
voltage	180
fundamental current	
harmonic limits	141

G

GFRQ?	206
GMEM	187
GMUL	205
GTL	225

H

half wave	
crest factor	170
half wave power	155
half wave TRMS	153; 157
harmonic limit	
partial odd	166
harmonic limits	
fundamental current	141
power	142
power factor	142
rsce	142
harmonic standard	
version, edition	143
harmonics	
active power	168
apparent power	168
average current amplitude	162
class D result	161
current amplitude	162
current check result	163; 166
current limits	164
current phases	165
current result	165
evaluation	140
fluctuating current result	163
interharmonics current	164
interharmonics voltage	170
maximum amplitude voltage	171
maximum averaged fundamental current	162
maximum duration	163
measuring time	196
partial odd current	165

INTS?	197
INTT	198
IP	165
IPHI?	147
Ipkn	147
Ipkp	147
Ipohc	165
Ipp	147
IPP?	147
IREC?	147
Irect	147
IRNG	191
ISCA	191
Iscal	191
ISO	141
Ithc	167
Ithd	167
Itrms	148
ITRMS?	148
<hr/>	
K	
KEY	218
<hr/>	
L	
LEN	226
level	
extended trigger	224
limit	
current harmonics	164
damx	141
partial odd harmonic	166
voltage harmonics	171
limits	
digital outputs	209
transients	200
list	
ranges	
current	191
voltage	204
list data	134
local state	225
<hr/>	
M	
maximum	
averaged fundamental current	162
current	147
voltage	181
maximum amplitude voltage harmonics	171
maximum crest factor	
voltage	171
maximum duration	
current harmonics	163
maximum phase	
peak value voltage	172
maximum smoothed power	160
maximum smoothed power factor	160
measuring cycle	
real time	149
measuring cycle counter	148
measuring mode	186
measuring time	
harmonics	196
short term flicker	194
measuring values	
actualisation	184
memory size	187
minimum	
current	147
voltage	181
minimum crestfactor	
voltage	172
minimum phase	
peak value voltage	172
MODE	186
integration	197
measuring	186
momentary flicker level	153; 157
averaged	152; 155
Mtime	149
<hr/>	
N	
new information about waveform	205
nquery	134
number of errors	216
NVAR?	179
<hr/>	
O	
oldest error	216
Operation Status	
Condition Register	211
Enable Register	211
Event Register	211
Negative Transition Register	211
Positive Transition Register	212
options	
installed	219
over x	
transients	202
OvrI	148

OVRI?	148
OvrU	182
OVRU?	182

P

P	175
P?	175
Parallel Poll Enable Register	137
Partial odd harmonic current	165
Partial odd harmonic limit	166
peak peak	
current	147
voltage	181
periods	
flicker	194
PF	176
PF?	176
PFSO	142
Ph	168
phantom values	
reject	198
phase	
current harmonics	165
Fresnel	195
maximum peak voltage	172
minimum peak voltage	172
reference	195
voltage harmonics	173
phase angle	176
current	147; 181
voltage peak	173
PHDR	219
PHI	176
PHI?	176
Plt	153; 157
Pltl	153
Plts	157
Pm	174
PM?	174
Pml	153
Pmoml	152
Pmoms	155
Pms	157
power	
active	175
apparent	175
average active	174
average apparent	174
average reactive	175
capacitive	176
distortion	168
full scale	175
half wave	155

harmonic limits	142
inductive	176
maximum smoothed	160
reactive	176
smoothed	161
power factor	176
harmonic limits	142
maximum smoothed	160
smoothed	160
PRES	212
Preset	
operation and query registers	212
pretrigger	
transients	201
printer header	219
processing signal interface	
frequency	159
PSO	142
Pst	154; 157
Pstl	154
Psts	157

Q

q	150; 176
Q?	176
Qh	169
Qm	175
QM?	175
qonly	133
Questionable Status	
Condition Register	212
Enable Register	213
Event Register	213
Negative Transition Register	213
Positive Transition Register	213

R

range	
current	191
voltage	204
range usage	
current	148
voltage	182
ranges	
current	191
voltage	204
ratio	
frequency divider	195
reactive	
energy	151
reactive power	176

harmonics.....	169
reactive serial impedance.....	177
real measuring time.....	149
record time	
transients.....	201
rectified	
current.....	147
voltage.....	182
reference	
phase.....	195
reference impedance.....	143
register	
Event Status.....	136
Event Status Enable.....	135
Operation Status Enable.....	211
Operation Status Event.....	211
Operation Status Negative Transition.....	211
Operation Status Positive Transition.....	212
Parallel Poll Enable.....	137
Preset	
operation and query.....	212
Questionable Status Condition.....	212
Questionable Status Enable.....	213
Questionable Status Event.....	213
Questionable Status Negative Transition.....	213
Questionable Status Positive Transition.....	213
Service Request Enable.....	138
Status Byte.....	138
reject phantom values.....	198
remaining long time	
flicker.....	154
harmonics.....	167
remaining short time.....	158
remote - operation.....	226
remote state.....	226
reset.....	221
device.....	137
display.....	144
energy.....	221
resistance	
active serial.....	177
impedance.....	177
result	
class D.....	161
current fluctuating harmonics.....	163
current harmonics.....	165
flicker.....	158
flicker measuring.....	154
harmonics current check.....	163; 166
harmonics voltage check.....	170; 173
voltage harmonics.....	171; 172
RLS?.....	178
RngI.....	191
RngU.....	204

RSCE.....	142
Rser.....	177
RSER?.....	177
running integration time.....	151

S

S.....	175
S?.....	175
SACT.....	205
sample counter	
trigger.....	206
sample cycles.....	205
number.....	205
sample values.....	207
memory size.....	187
saving ratio.....	206
sample values after trigger.....	205
sample values before trigger.....	206
sample values stored in memory.....	206
sampling frequency.....	159
SATR?.....	205
SBTR?.....	206
scaling	
current.....	191
frequency input.....	193
voltage.....	204
scope	
freeze.....	186
SCPI	
example.....	228
version.....	220
SCPI headers.....	217
script editor.....	140
SCTC?.....	149
SCTT?.....	206
self test.....	138
sensor	
identify current.....	190
identify voltage.....	203
Service Request Enable Register.....	138
Sh.....	168
SHEAD?.....	217
SHORT	
example.....	230
SHORT headers.....	217
short term flicker measuring time.....	194
shunt input	
internal/external.....	189
signal	
transients.....	202
signal coupling.....	185
Sm.....	174

SM?	174
SMOO	195
smoothed	
average harmonic current	166
harmonic current	166
smoothed power	161
smoothed power factor	160
smoothing	
harmonics	195
SMPL?	159
SOC?	211
SOE?	211
SOEN	211
SONT	211
SOPT	212
source	
extended trigger	224
SQC?	212
SQE?	213
SQEN	213
SQNT	213
SQPT	213
SSAM	206
START	222
energy	222
flicker	222
start date	
energy	196
start time energy	198
startup current	146
reset	221
state	
energy	197
flicker	158
local	225
remote	226
state transientes	178
Status Byte Register	138
STOP	222
energy	222
flicker	222
supply system	142; 178
SYNC	225
synchronisation	
source	225
synchronisation source	
frequency	159
syntax	133
SYSD	142
system	
supply	142; 178
system date	214
system time	220

T

TACR	199
TDT	202
TDU	202
TDUR	200
TDX	202
test impedance	143
THD	
current	167
voltage	174
time	220
cycle	199
measuring harmonics	196
running integration	151
short term flicker measuring time	194
start energy	198
system	220
time interval	
energy	197
TLIA	200
TLIB	200
TOCR	201
Total harmonic current	167
TPRE	201
transients	
AND condition register	199
channels	200
dt	202
dy	202
event duration	200
limits	200
OR condition register	201
over x	202
pretrigger	201
record time	201
signal	202
state	178
TRCH	200
TRDE	224
TRDF	223
TRDH	224
TRDL	224
TREC	201
Trigger	138
coupling mode	223
hysteresis	224
inrush current	221
level	224
sample counter	206
source	224; 225
triggerung	
filter	223
TRMS	

current.....	148
half wave.....	153; 157
voltage.....	182
TSRC.....	202
TSTA?.....	178

U

Uac.....	179
UAC?.....	179
UAM.....	203
Ucf.....	180
UCF?.....	180
Udc.....	180
UDC?.....	180
Uff.....	180
UFF?.....	180
Uh.....	169
Uhw1.....	153
Uhws.....	157
UILS.....	204
UL.....	171
UMax.....	171
UMAX?.....	181
UMIN?.....	181
UP.....	173
UPHI?.....	181
Upkn.....	181
Upkp.....	181
Upp.....	181
UPP?.....	181
UREC?.....	182
Urect.....	182
URNG.....	204
USCA.....	204
Uscal.....	204
Uthd.....	174
Utrms.....	182
UTRMS?.....	182

V

value	
analogue outputs.....	210
digital outputs.....	209
VAR?.....	178
variables.....	178
access by name.....	179
version	
flicker standard.....	141
harmonic standard.....	143
voltage	

AC.....	179
analogue input.....	179
autorange.....	203
crest factor.....	180
DC.....	180
form factor.....	180
full scale.....	180
harmonics amplitude.....	169
harmonics limit.....	171
harmonics phase.....	173
harmonics result.....	171; 172
interharmonics.....	170
maximum.....	181
maximum crest factor.....	171
maximum harmonics amplitude.....	171
maximum phase.....	172
minimum.....	181
minimum crestfactor.....	172
minimum phase.....	172
peak peak.....	181
peak phase angle.....	173
phase angle.....	181
range.....	204
range usage.....	182
rectified.....	182
scaling.....	204
THD.....	174
TRMS.....	182
voltage sensor	
identify.....	203

W

Wait.....	139
WAVE?.....	207
waveform	
new information about.....	205
sample values.....	207
sample values after trigger.....	205
sample values before trigger.....	206
sample values stored in memory.....	206
WIRE.....	207
wiring.....	207

X

Xser.....	177
XSER?.....	177

Z

Z.....	177
--------	-----

Z?	177	analogue output	210
zero point rejection	208	ZREF	143
zero position		ZTST	143
analogue input	188		